

SECTION D

ALL SERIES DELCO MORAINÉ POWER BRAKES

CONTENTS

Division	Paragraph	Subject	Page
I	50-12	SPECIFICATIONS AND ADJUSTMENTS:	
		Power Brake Specifications	50-55
II	50-13 50-14	DESCRIPTION AND OPERATION:	
		Description of Power Brakes	50-56
		Operation of Power Brakes	50-56
III	57-1 57-2 57-3 57-4 57-5 57-6	SERVICE PROCEDURES:	
		Removal of Power Brake Unit	50-61
		Disassembly of Power Brake Unit	50-62
		Cleaning and Inspection of Power Brake Unit	50-65
		Assembly of Power Brake Unit	50-67
		Installation of Power Brake Unit	50-69
		Testing of Power Brake Unit	50-69
IV	59-5	TROUBLE DIAGNOSIS:	
		Power Brake Trouble Diagnosis	50-70

DIVISION I SPECIFICATIONS AND ADJUSTMENTS

50-12 POWER BRAKE SPECIFICATIONS

The following specifications are for the power brake power unit only. Specifications for brake shoe adjustment and parking brake adjustment will be found in Section A.

a. Tightening Specifications

Use a reliable torque wrench to tighten the parts listed to insure proper tightness without straining or distorting parts. These specifications are for clean and lightly lubricated threads only; dry or dirty threads produce increased friction which prevents accurate measurements of tightness.

Part	Location	Thread Size	Torque
Nut	Power Brake Assembly to Dash	3/8-16	24 lb. ft.
Nut	Hydraulic Master Cylinder to Power Unit	3/8-16	24 lb. ft.
Fitting	Vacuum Pipe to Intake Manifold	—	120 lb. in. (Min.)
Nut, Fitting	Vacuum Pipe to Manifold Fitting (43-44000)	—	120 lb. in.
Screw	Vacuum Pipe (Hose) Bracket to Engine	3/8-16	15 lb. ft.
Nut	Clevis Locking (43-44000)	3/8-24	14 lb. ft.

b. General Specifications

Operating Mechanism	Vacuum-Hydraulic
Brake Pedal Height Adjustment	None
Hydraulic Master Cylinder Piston Diameter, Drum Brakes	1"
Hydraulic Master Cylinder Piston Diameter, Disc Brakes	1-1/8"
Approved Hydraulic Brake Fluid	GM or Delco Supreme No. 11 or Equivalent

DIVISION II**DESCRIPTION
AND OPERATION****50-13 DESCRIPTION OF POWER BRAKE
MECHANISM****a. General Description of
Power Brake Unit**

The Delco Moraine Power Brake Unit is a combined vacuum and hydraulic unit which utilizes engine intake manifold vacuum and atmospheric pressure to provide power-assisted application of vehicle brakes. The unit takes the place of the master cylinder in a conventional brake system. From the master cylinder connection outward to the wheel units, there is no other change in the brake system. In addition to the master cylinder connections, the unit requires a vacuum connection to the engine intake manifold (through a vacuum check valve) and a mechanical connection to the brake pedal. As shown in Figure 50-50, 51 or 52, the unit is self-contained with no external rods or levers exposed to dirt or moisture.

The power brake unit provides lighter pedal pressures. These lighter pedal pressures are obtained in combination with reduced pedal travel making it possible to bring the brake pedal down to the approximate height of the accelerator pedal when at closed throttle position. Thus, the driver after closing the throttle can shift his toe from one pedal to the other without lifting his heel from the floor.

The vacuum check valve mounted on the power brake unit front housing permits several applications of the power brake unit with vacuum-assist after the engine has stopped or after any other loss of vacuum. When the vacuum stored in the unit has been lost or in case of vacuum failure at

the unit or its vacuum connections, the brakes can be applied in the conventional manner. Since the vacuum assist is not available, the pedal pressure will be greater.

b. Construction of Power Brake Unit

The unit is composed of two main sections: the vacuum power cylinder and the hydraulic master cylinder.

The vacuum power cylinder contains the power piston assembly which houses the control valve and reaction mechanism and the power piston return spring. The control valve is composed of the air valve and the floating control valve assembly. The reaction mechanism consists of a hydraulic piston reaction plate and series of levers. An air filter element is assembled around the push rod and fills the cavity inside the hub of the power piston. The push rod, which operates the air valve, projects out of the end of the power cylinder housing through a boot. A vacuum check valve assembly is mounted in the front housing assembly for connection to the vacuum source.

Two separate fluid reservoirs are integrally cast with the master cylinder and supply fluid to the space between the primary and secondary cups on each hydraulic piston through a hole in the bottom of each reservoir.

Connection is made to the wheel cylinders through the hydraulic outlets and a check valve.

**50-14 OPERATION OF POWER
BRAKE UNIT**

1. Released Position. A line from the engine intake manifold is connected to the vacuum check valve in the front housing of the power brake. This check valve prevents loss of vacuum when manifold vacuum falls below that in the power brake system.

In the released position, the air valve is seated on the floating control valve. See Figure 50-53. The air under atmospheric pressure, which enters through the filter element in the tube extension of the power piston, is shut off at the air valve. The floating control valve is held away from the valve seat in the power piston. Vacuum, which is present at all times in the space to the front of the power piston, is free to evacuate any existing air on the rear side of the power piston. This air is drawn through two small passages in the power piston, over the valve seat in the power piston and then through the power piston into the space at the front of the power piston. It is then drawn through the check valve and thence to the vacuum source.

In this position, there is vacuum on both sides of the power piston and the power piston is held against the rear housing by the power piston return spring. At rest, the hydraulic reaction plate is held against the reaction retainer. The reaction levers are held back against the hydraulic reaction plate by the air valve spring. The air valve spring holds back so that its retaining ring rests against the power piston.

The floating control valve assembly is held against the air valve seat by the floating control valve spring. In this position, the bypass holes in the hydraulic master cylinder are open to the reservoir and fluid can flow freely in either direction between the hydraulic cylinder and the fluid reservoir.

A residual pressure is maintained in the brake lines by the check valve and its spring.

2. Applying Position. As the pedal is depressed, the push rod carries the air valve away from the floating control valve. See Figure 50-54. The floating control valve will follow until it is in contact with the raised seat in the

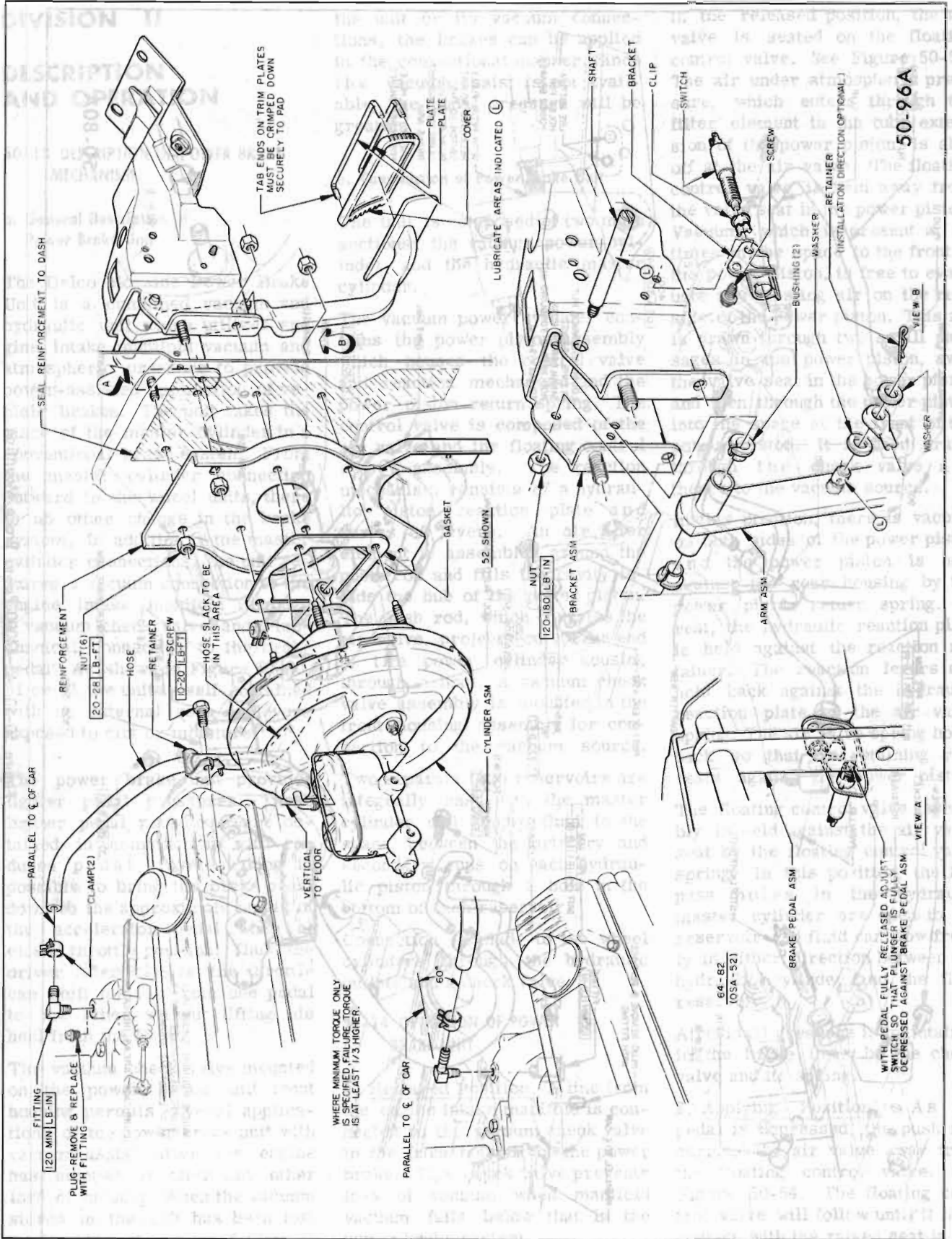

Figure 50-51 45-46-48000 Power Brake Mounting

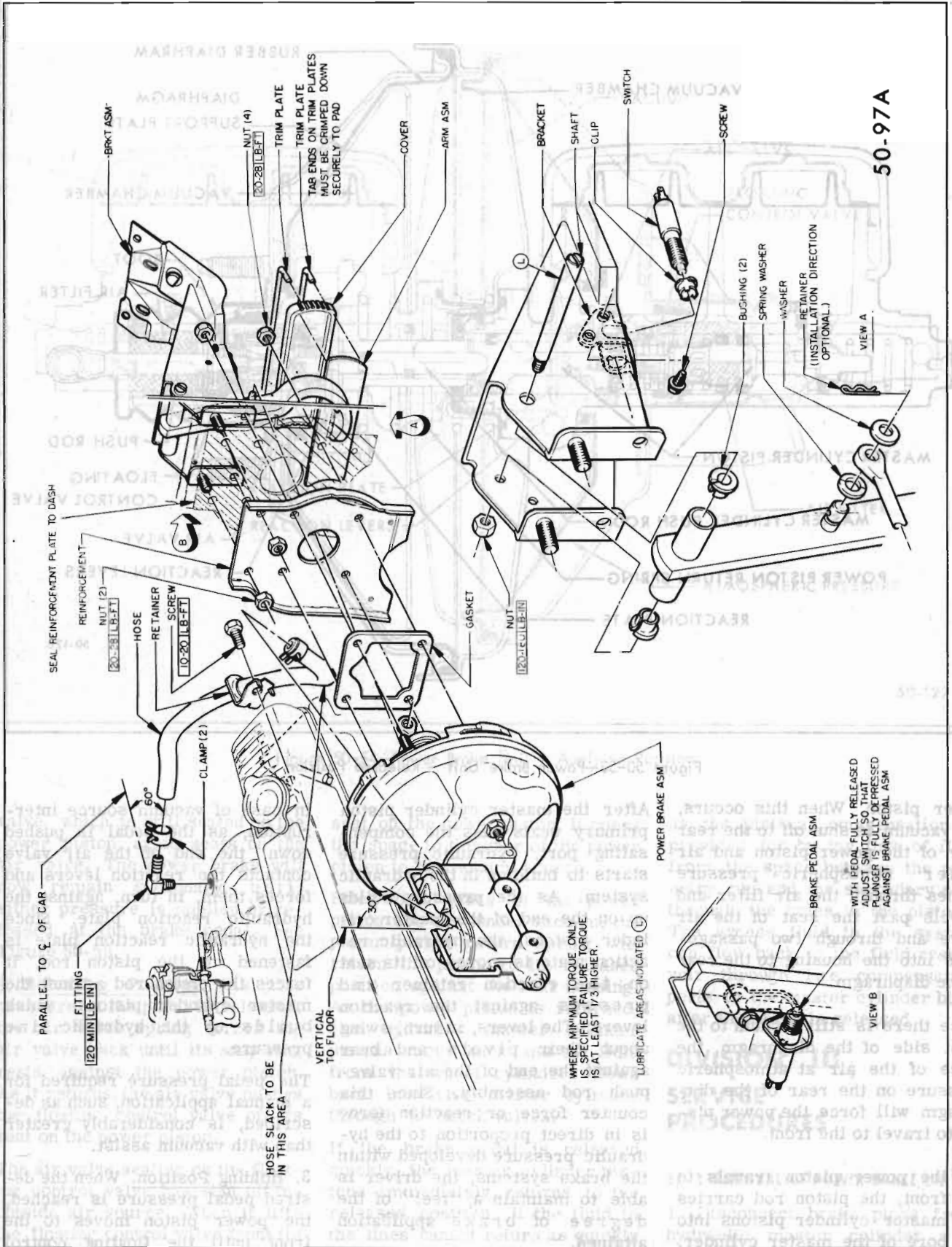
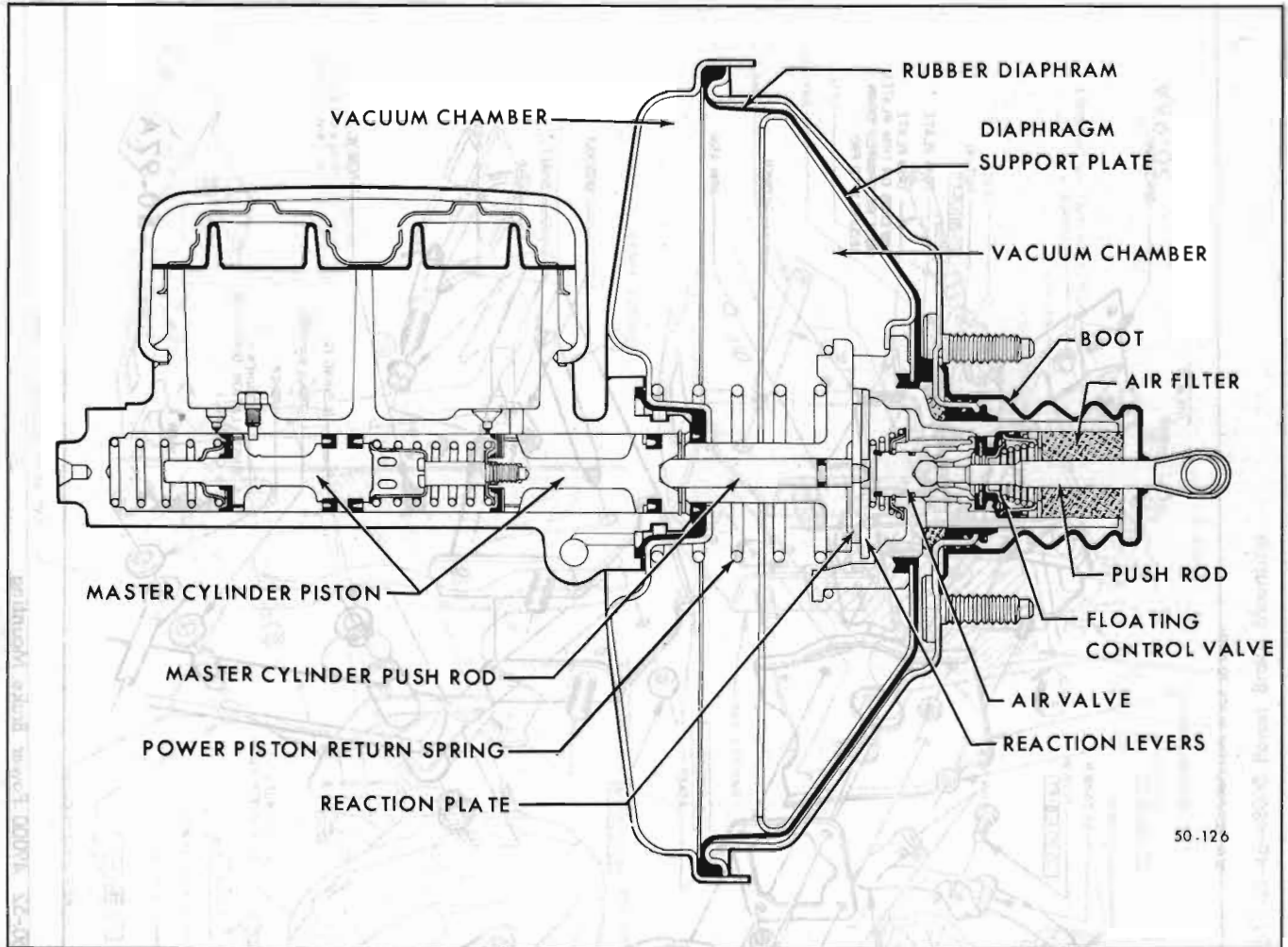

Figure 50-52 49000 Power Brake Mounting



50-126

Figure 50-53—Power Brake Unit - Released Position

power piston. When this occurs, the vacuum is shut off to the rear side of the power piston and air under atmospheric pressure rushes through the air filter and travels past the seat of the air valve and through two passageways into the housing to the rear of the diaphragm.

Since there is still vacuum to the front side of the diaphragm, the force of the air at atmospheric pressure on the rear of the diaphragm will force the power piston to travel to the front.

As the power piston travels to the front, the piston rod carries the master cylinder pistons into the bore of the master cylinder.

After the master cylinder piston primary seals pass the compensating port, hydraulic pressure starts to build up in the hydraulic system. As the pressure builds up on the end of the master cylinder pistons, the hydraulic reaction plate is moved off its seat on the reaction retainer and presses against the reaction levers. The levers, in turn, swing about their pivots and bear against the end of the air valve-push rod assembly. Since this counter force or reaction force is in direct proportion to the hydraulic pressure developed within the brake systems, the driver is able to maintain a "feel" of the degree of brake application attained.

In case of vacuum source interruption, as the pedal is pushed down, the end of the air valve contacts the reaction levers and forces them, in turn, against the hydraulic reaction plate. Since the hydraulic reaction plate is fastened to the piston rod, it forces the piston rod against the master cylinder pistons, which builds up the hydraulic line pressure.

The pedal pressure required for a manual application, such as described, is considerably greater than with vacuum assist.

3. Holding Position. When the desired pedal pressure is reached, the power piston moves to the front until the floating control

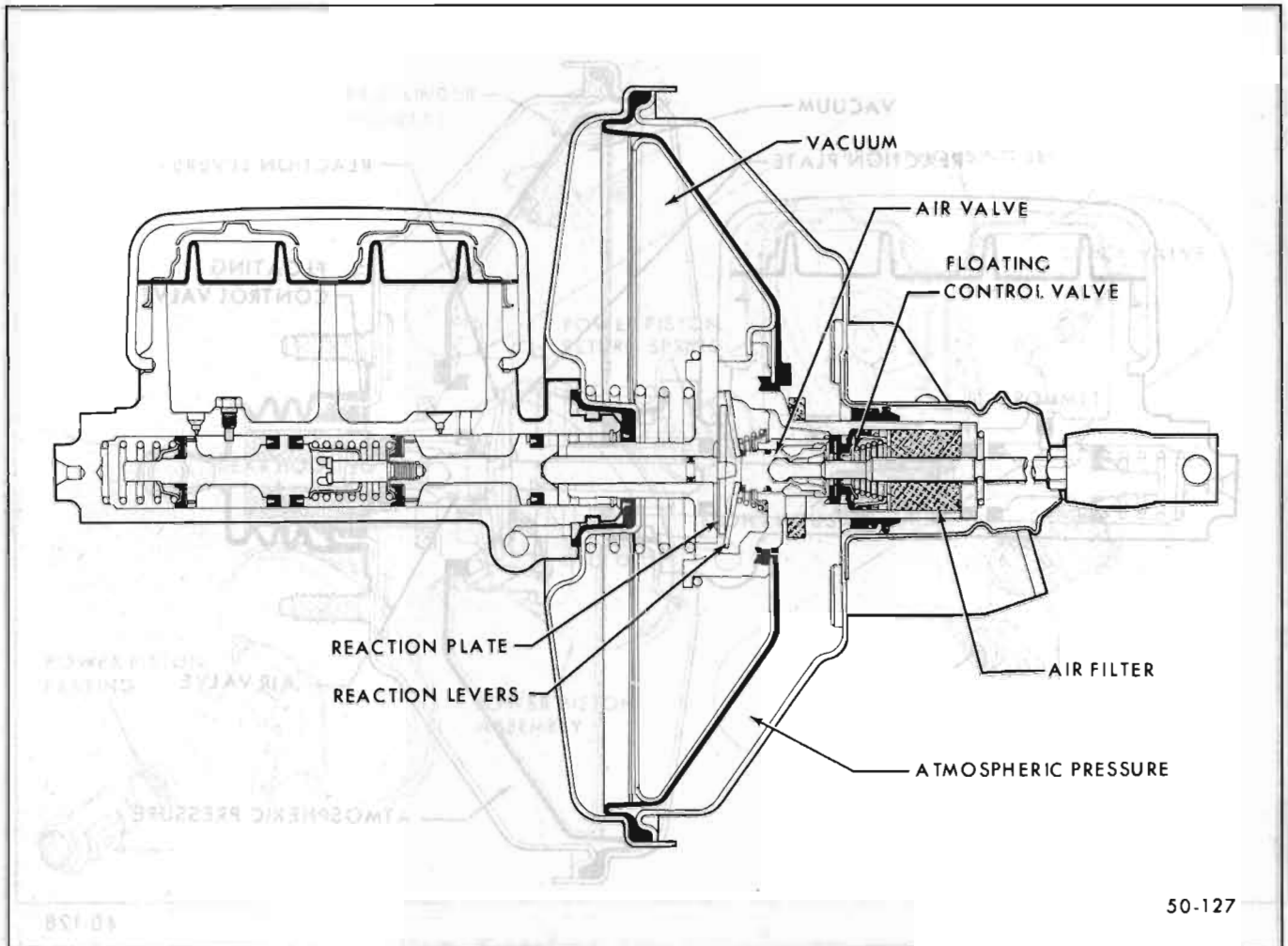

50-127

Figure 50-54—Power Brake Unit - Applying Position

valve, which is still seated on the power piston, again seats on the air valve. The power brake will now remain stationary, until either pressure is applied or released at the brake pedal. See Figure 50-55.

4. Releasing Position. As the pressure at the pedal is released, the air valve spring forces the air valve back until its snap ring rests against the power piston. As it returns, the air valve pushes the floating control valve off its seat on the power piston.

The air valve seating on the floating control valve has shut off the outside air source. When it lifts the floating control valve from its

seat on the power piston, it opens the space to the rear of the power piston to the vacuum source.

Since both sides of the power piston are now under vacuum, the power piston return spring will return the piston to its released position against the rear housing. As the power piston is returned, the hydraulic master cylinder pistons move back and the fluid from the wheel cylinders flows back into the master cylinder through the check valves.

If the brake pedal is released quickly, the master cylinder pistons immediately returns to the released position. If the fluid in the lines cannot return as quickly

as the pistons, compensation is provided for by the flow of fluid from the space between the primary cup and the secondary seal through the holes in the pistons. The excess fluid in the system can flow back to the fluid reservoir through the compensating ports in the master cylinder bore after the brake is released.

DIVISION III SERVICE PROCEDURES

57-1 REMOVAL OF POWER BRAKE UNIT

1. Disconnect brake pipes from hydraulic master cylinder and

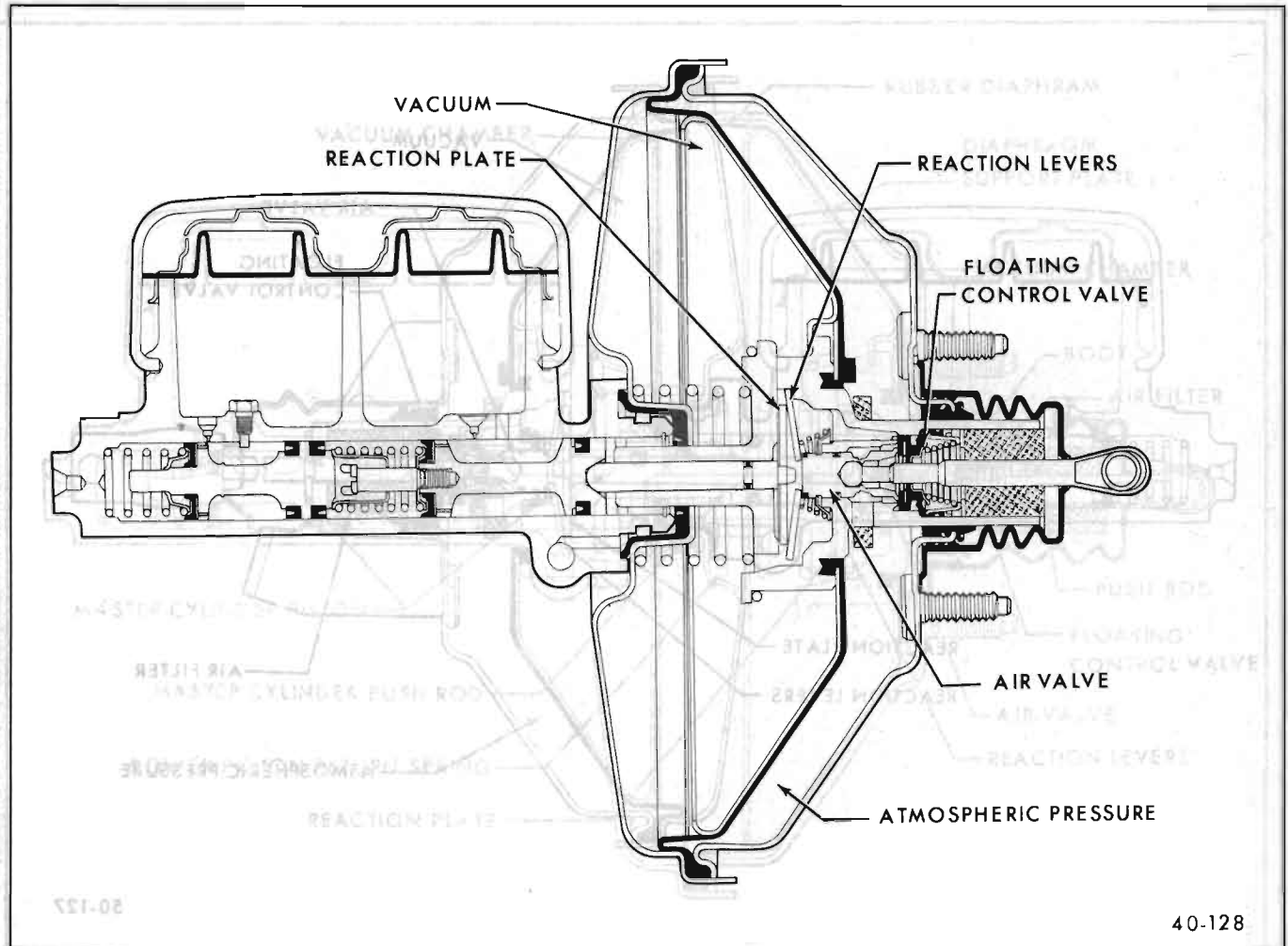

Figure 50-55—Power Brake Unit - Holding Position

tape ends of pipes to prevent entrance of dirt.

2. Disconnect vacuum hose from power brake unit.

3. Remove four nuts holding power brake unit to dash.

4. Remove retainer and washer from brake pedal pin and disengage push rod clevis.

5. Remove power brake unit from car, being careful not to allow brake fluid to drip on exterior paint.

6. Remove reservoir cover and position unit so that brake fluid will drain out. Pump push rod by hand for full interior drainage.

Discard old fluid. Install reservoir cover and diaphragm and cover hydraulic master cylinder outlets with tape to exclude dirt. Clean all loose dirt from outside of unit before disassembling.

57-2 DISASSEMBLY OF POWER BRAKE UNIT

NOTE: For master cylinder disassembly and assembly, see Section A, paragraph 55-1.

a. Disassembly of Power Brake Unit

1. Remove reservoir cover and diaphragm to avoid damage. Place

power brake assembly in a vise with push rod up. Clamp unit firmly on sides of master cylinder reservoir.

NOTE: Scribe a mark on bottom center of front and rear housings to facilitate reassembly.

2. Remove boot and place two adjustable wrenches at least 10" in length, so that each wrench will grip on a mounting bracket (43-44000) or attach wrench J-9504 to studs (45-46-48-49000). Rotate rear housing counterclockwise to unlocked position. See Figure 50-57 or 58.

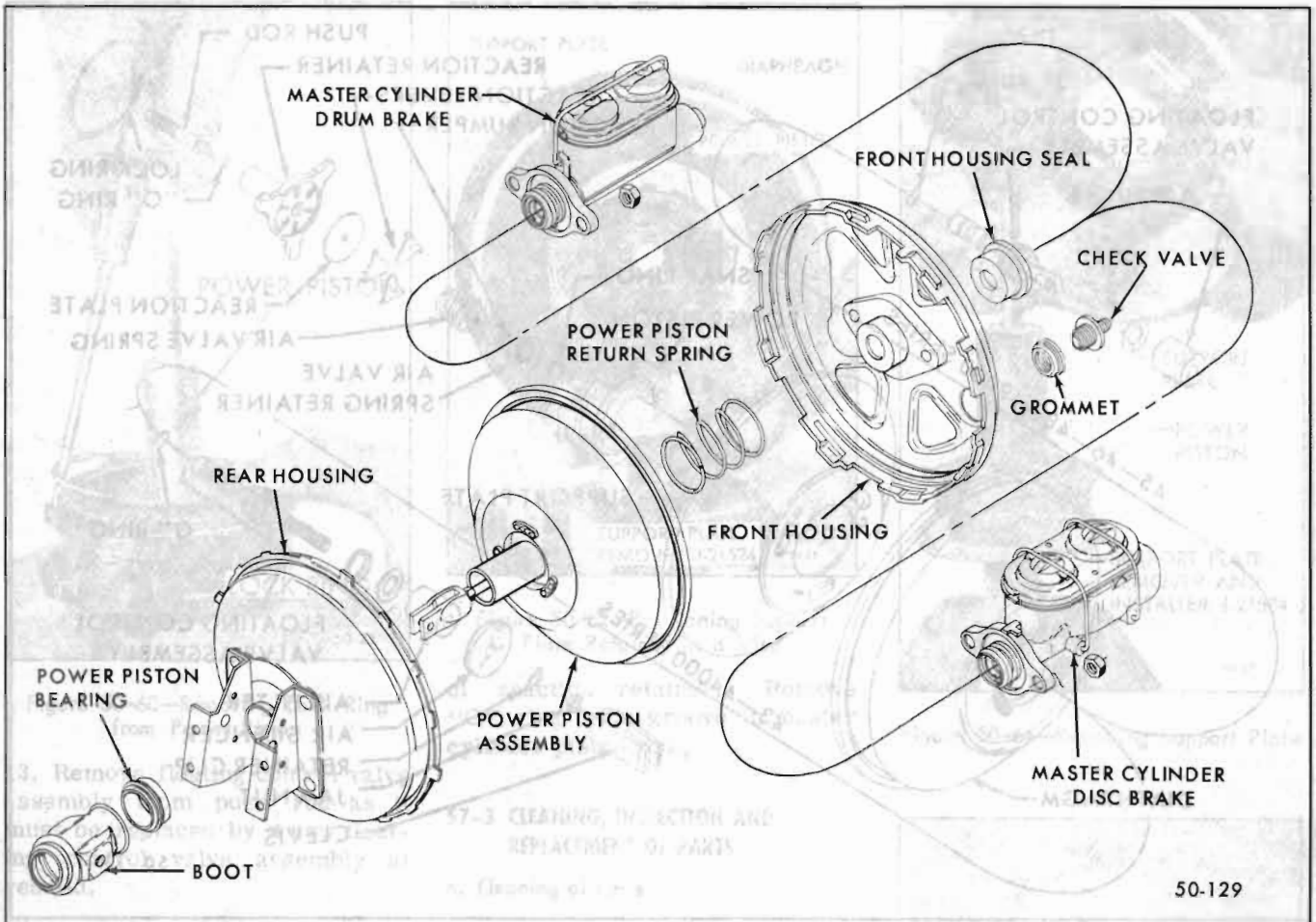

50-129

Figure 50-56—Power Brake Unit - Exploded View

CAUTION: Loosen housing carefully as it is spring-loaded.

3. Lift rear housing and power piston assembly from unit. Then remove return spring.



Figure 50-57 43-44000 Separating Power Brake Unit

4. Remove clevis and jam nut (43-44000) from push rod. Remove retaining ring on push rod that holds silencer in place on push rod (43-44000). Remove silencer.

5. Reposition master cylinder assembly in vise to facilitate removal of front housing from master cylinder. Remove master cylinder to front housing attaching nuts.

6. Remove seal from front housing, and if defective, vacuum check valve.

b. Disassembly of Power Piston Assembly

Caution must be used in handling the diaphragm of power piston

assembly. Guard diaphragm against grease, oil, foreign matter and nicks or cuts.

1. Remove power piston assembly from rear housing.



50-130

Figure 50-58 45-46-48-49000 Separating Power Brake Unit

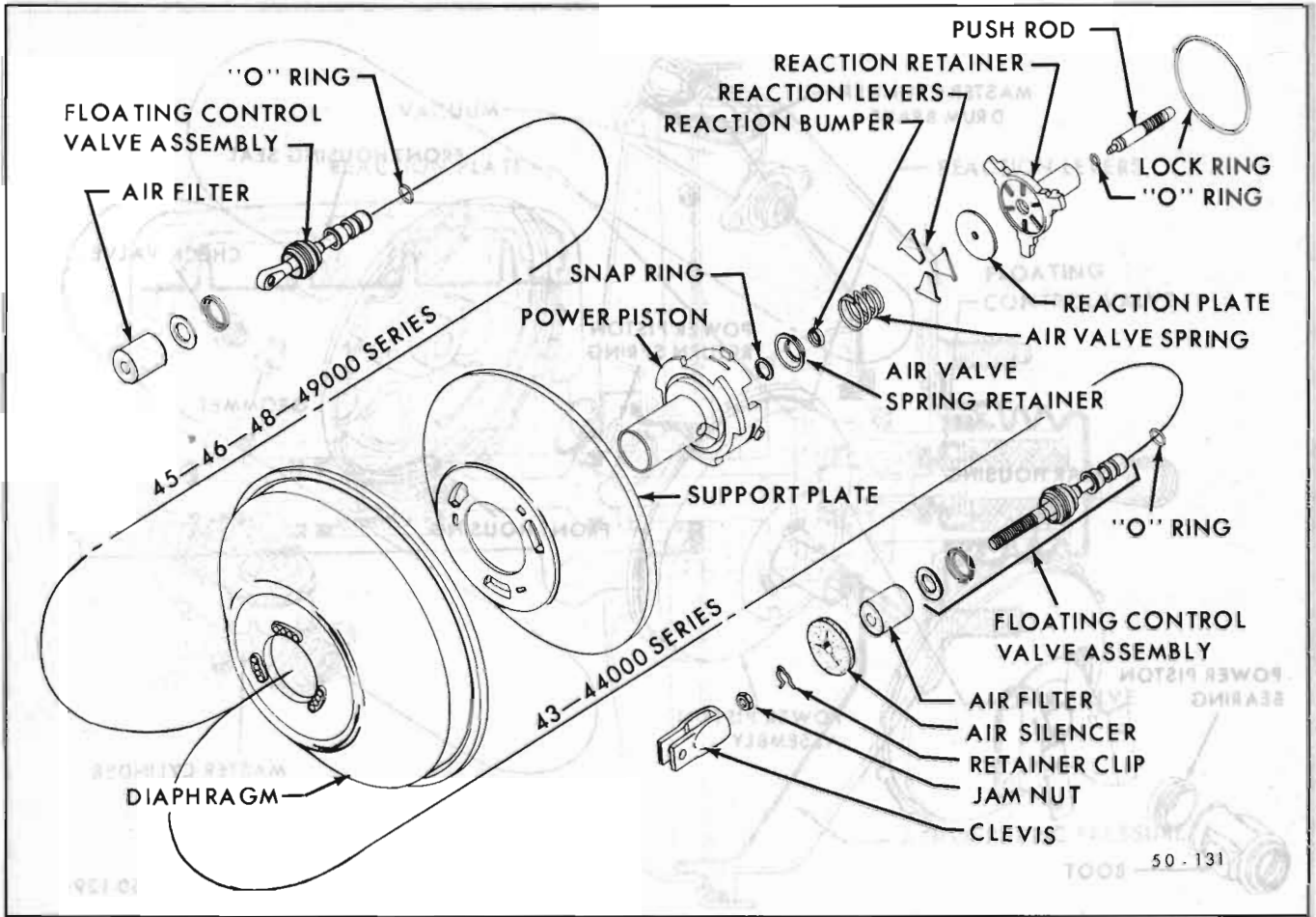

Figure 50-59 Power Piston Assembly - Exploded View

2. Remove silencer from neck of power piston tube.
3. Remove lock ring from power piston by prying one of end out from under large divided locking lug and then proceed to pull ring from under other two locking lugs on power piston. See Figure 50-60.
4. Remove reaction retainer, piston rod, reaction plate, three (3) reaction levers and air valve spring. Also remove reaction bumper and air valve spring retainer from air valve. See Figure 50-61.
5. Place power piston Wrench J-21524 with square shank in

vise. Hold support plate and power piston with tube of power piston up. See Figure 50-62.

6. Pull diaphragm edges away from support plate so hands can grip steel support plate. Position assembly on power piston Wrench J-21524 so three lugs on tool fit into three notches in power piston. See Figure 50-63.

7. Press down on support plate and rotate counterclockwise until support plate separates from power piston. See Figure 50-64.

8. Remove diaphragm from support plate and lay both parts aside.

9. Position power piston, tube down, in a vise padded with shop towels.

NOTE: Do Not Clamp on Tube. The outside surface of tube acts as a bearing surface.

10. Use #22 Truarc Pliers or J-4880 to remove snap ring on air valve. See Figure 50-65.

11. Set up Power Ram and Hydraulic Pump with J-9746 Press Plate. Insert power piston, tube down, in press plate and remove air valve assembly using a 3/8" drive extension as a remover. See Figure 50-66.

12. Removal of air valve push rod assembly disassembles the following parts from power piston: floating control valve assembly, floating valve retainer, push rod limiter washer and air filter.

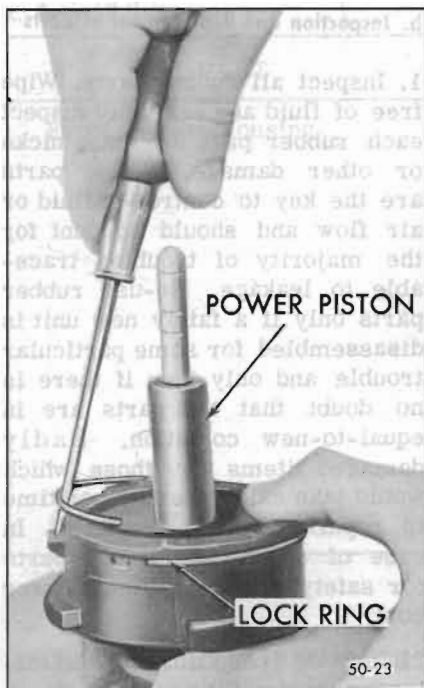

Figure 50-60—Removing Lock Ring from Power Piston

13. Remove floating control valve assembly from push rod as it must be replaced by a new floating control valve assembly at rebuild.

14. The master cylinder push rod can now be pushed from center

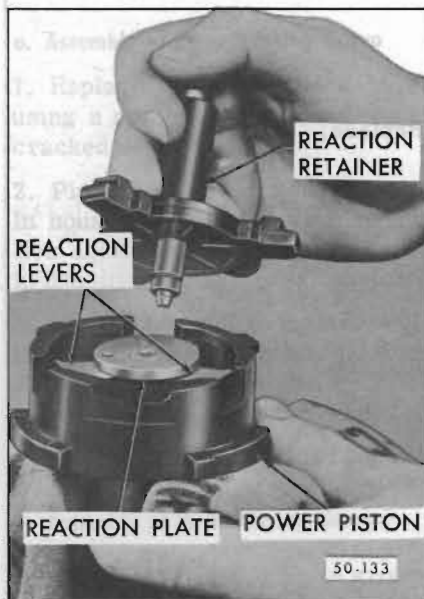

Figure 50-61—Removing Reaction Retainer



Figure 50-62—Positioning Support Plate Retainer in a Vise

of reaction retainer. Remove "O" ring from groove in master cylinder piston rod.

57-3 CLEANING, INSPECTION AND REPLACEMENT OF PARTS

a. Cleaning of Parts

1. Use Declene or denatured alcohol to clean thoroughly all



Figure 50-63—Positioning Power Piston on Support Plate Remover

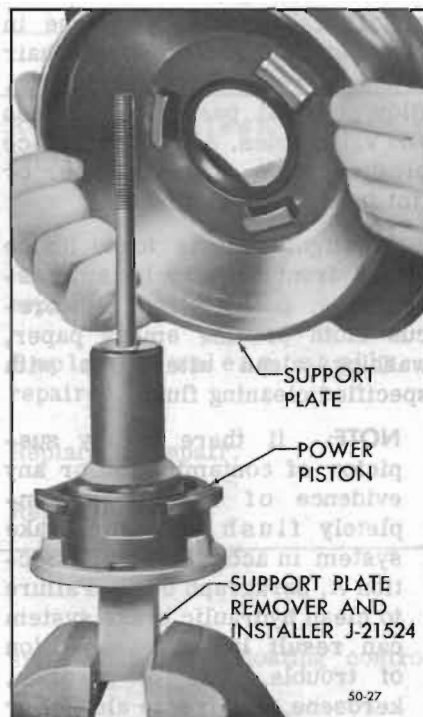

Figure 50-64—Removing Support Plate

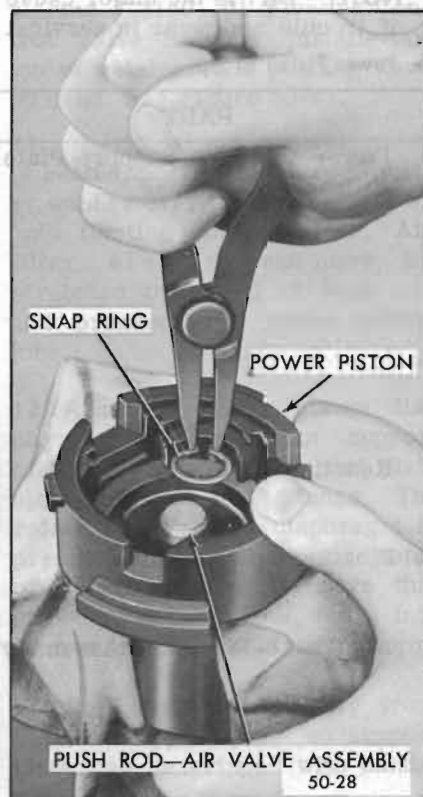

Figure 50-65—Removing Power Piston Snap Ring

metal brake parts. Immerse in cleaning fluid and brush with hair brush to remove foreign matter. Blow out all passages, orifices and valve holes. Air dry and place cleaned parts on clean paper or lint free clean cloth.

2. If slight rust is found inside either front or rear housing assemblies, polish clean with crocus cloth or fine emery paper, washing clean afterwards with specified cleaning fluid.

NOTE: If there is any suspicion of contamination or any evidence of corrosion, completely flush hydraulic brake system in accordance with Section A, paragraph 56-2. Failure to clean hydraulic brake system can result in early repetition of trouble. Use of gasoline, kerosene, anti-freeze alcohol or any other cleaner with even a trace of mineral oil will damage rubber parts.

NOTE: Dirt is the major cause of trouble and wear in service.

b. Power Piston Group

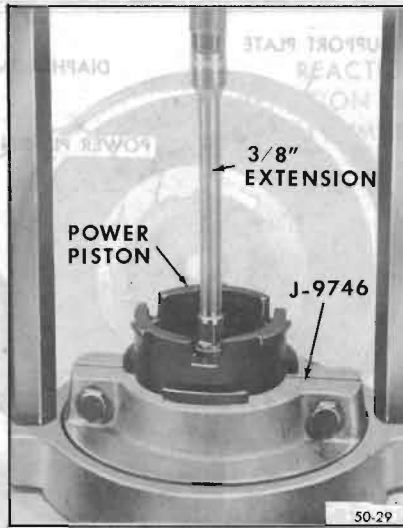

Figure 50-66—Removing Air Valve Assembly

Be sure to keep parts clean. Rewash at reassembly if there is any occasion to doubt cleanliness--such as parts dropped or left exposed for eight hours or longer.

b. Inspection and Replacement of Parts

1. Inspect all rubber parts. Wipe free of fluid and carefully inspect each rubber part for cuts, nicks or other damage. These parts are the key to control of fluid or air flow and should account for the majority of troubles traceable to leakage. Re-use rubber parts only if a fairly new unit is disassembled for some particular trouble and only then if there is no doubt that the parts are in equal-to-new condition. Badly damaged items or those which would take extensive work or time to repair should be replaced. In case of doubt, install new parts for safety and for ultimate lower cost.

2. Inspect in accordance with following table: (The table is organized by power brake unit groups.)

a. Master Cylinder Group

See Section A, paragraph 55-1.

PART	INSPECT FOR	CORRECTIVE ACTION
Power Piston & Support Plate & Reaction Retainer	Cracks, distortion chipping, damaged lever seats, pitted or rough holes. Worn seal surfaces (tubes). Rough or uneven floating valve seat. Open passages and flow holes.	Cleanup or replace. Replace. Clean.
Reaction Levers or Plates	Cracks, distortion, tears and heavy wear.	Replace.
Floating Control Valve	Deterioration of rubber or warped valve face.	Replace.
Air Valve-Push Rod Assembly	Air valve: scratches, dents, distortion, or corrosion of I.D. or O.D. All seats to be smooth and free of nicks and dents. Push rod must move freely in air valve, but must not pull out.	Do not repair; replace. If worn, replace air valve-push rod assembly.

c. Over-All Unit

PART	INSPECT FOR	CORRECTIVE ACTION
Front & Rear Housing	Scratches, scores, pits, dents or other damage affecting rolling or sealing of diaphragm or other seals.	Replace unless easily repaired.
	Cracks, damage at ears, damaged threads on studs.	Replace unless easily repaired.
	Bent or nicked locking lugs.	Replace unless easily repaired.
	Loose studs.	Replace or repair.
Air Filters & Silencer	Dirty	Replace

57-4 ASSEMBLY OF POWER BRAKE UNIT

Be certain that all rubber parts are clean at reassembly. Rewash in specified cleaning fluid if there is any doubt of cleanliness. Be careful during rebuild process that no grease or mineral oil comes in contact with rubber parts of power brake unit. Lubricate rubber parts with Delco Moraine approved lubricant or equivalent.

a. Assembly of Front Housing Group

1. Replace vacuum check valve using a new grommet if old one is cracked or damaged.
2. Place new front housing seal in housing so flat surface of cup lies against bottom of depression in housing.
3. Install hydraulic master cylinder on front housing. Do not tighten nuts as master cylinder must again be removed for gaging.

b. Assembly of Power Piston Group

1. Place new "O" ring in groove on the master cylinder piston rod. Wipe a thin film of Power Brake Lube or equivalent on "O" ring.

2. Master cylinder piston rod is now inserted through the reaction retainer so round end of piston rod protrudes from end of tube on reaction retainer.

3. Place J-21524 power piston wrench in a vise. Position power piston on wrench with three lugs fitting into notches in power piston.

4. Position new "O" ring on air valve in second groove from push rod end.

5. On reassembly of power piston, floating control valve assembly must be replaced with a new one since the force required to remove it distorts component parts.

6. Place floating control valve on push rod-air valve assembly so flat face of valve will seat against valve seat on air valve.

7. Wipe a thin film of Power Brake Lube on large O.D. of floating control valve and on "O" ring on air valve.

8. Press air valve-push rod assembly, air valve first, onto its seat in tube of power piston.

9. Place floating control valve retainer over push rod so flat

side seats on floating control valve.

10. Start floating control valve and its retainer into power piston tube. Press the floating control valve to seat in the tube, by placing J-21601-01 Floating Control Valve Retainer Installer on top of retainer and pushing down by hand. See Figure 50-67.

11. After floating control valve is seated, position push rod limiter washer over push rod and down onto floating control valve. Air filter element can now be stretched over end of push rod and pressed into power piston tube.

12. Assemble power piston diaphragm to diaphragm support plate from side of support plate opposite locking tangs. The raised flange of diaphragm is pressed through hole in center of support plate. Be sure that edge of center hole fits into groove in flange of diaphragm.

13. Pull diaphragm away from O.D. of support plate so support plate can be gripped with hands.

14. With power piston still positioned on holding tool in vise,



Figure 50-67—Installing Floating Control Valve Assembly

coat bead of diaphragm that contacts power piston with Power Brake Lube.

15. Holding support plate by metal, with locking tangs down, place support plate and diaphragm assembly over tube of power piston. The flange of diaphragm will fit into groove on power piston. See Figure 50-68.

16. Press down and rotate support plate clockwise, until lugs on power piston come against stops on support plate.

17. This assembly can now be turned over and placed, tube down, in a padded vise (Do Not Clamp).

18. With a pair of #22 Truarc or J-4880 Pliers, assemble snap ring into groove in air valve.

19. Place air valve spring retainer on snap ring. Assemble



Figure 50-68—Installing Power Piston into Support Plate

reaction bumper into groove in end of air valve.

20. Position air valve return spring, large end down, on spring retainer.

21. The three reaction levers are now placed into position with ears on wide end in slots in power piston. The narrow ends will rest on top of air valve return spring.

22. Position reaction plate (with numbered side up) on top of reaction levers. Press down on plate until large ends of reaction levers pop up so plate rests flat on levers. Be sure reaction plate is centered.

23. Master cylinder piston rod and reaction retainer assembly is now assembled to the power piston.

24. With round end of piston rod up, and with reaction retainer held toward top of piston rod, place small end of piston rod in hole in center of reaction plate. Line up ears on reaction retainer with notches in power piston and

push reaction retainer down until ears seat in notches.

25. Maintain pressure on reaction retainer and position large lock ring down over master cylinder push rod.

26. There is a lug on the power piston which has a raised divider in the center. One end of lock ring goes under lug and on one side of divider.

27. As you work your way around power piston (either way), the lock ring goes over ear of reaction retainer, under a lug on power piston, and so forth, until other end of lock ring is seated under lug with raised divider.

Be sure both ends of lock ring are securely under large lug.

c. Assembly of Rear Housing Group

1. Place a new power piston bearing in center of rear housing so flange on center hole of housing fits into groove of power piston bearing. The large flange on power piston bearing will be on stud side of housing.

2. Coat inside of power piston bearing with Power Brake Lube.

d. Final Assembly of Power Brake Unit

1. Place air silencer over holes on tube of power piston. Wipe tube of power piston with Power Brake Lube.

2. Assemble power piston to rear housing.

3. Wipe tube of reaction retainer with Power Brake Lube and lay assembly aside.

4. Place front housing in a vise with master cylinder down. Position power piston return spring over inset in front housing. Lubricate the I.D. of support plate seal with Power Brake Lube.

5. Lightly lubricate beaded edge of diaphragm with Power Brake Lube. Hold rear housing and power piston assembly over front housing with master cylinder push rod down. Position rear housing so that when rotated into locked position, scribe marks on housings will be in line.

6. Place two adjustable wrenches on opposite brackets (43-44000) or attach Wrench J-9504 to studs 45-46-48-49000). Press down and rotate clockwise into locked position.

NOTE: Be extremely careful not to break studs loose in rear housing. Also, do not put pressure on power piston tube when locking housings.

7. Push felt silencer over push rod to seat against end of power piston tube. Snap ring retainer is now placed on push rod so it can hold silencer against power piston tube. Plastic boot is now pushed to seat against rear housing. Raised tabs on side of boot will locate in holes in center of brackets (43-44000). The jam nut and clevis can now be reassembled to push rod (43-44000).

e. Gaging Power Brake Piston

The following gaging operation is necessary only when a major structural part such as front or rear housing, power piston assembly, master cylinder piston or master cylinder assembly is replaced with a new part. The gauge measures how far the master cylinder push rod projects from front housing. This dimension must be correct to insure proper clearance in master cylinder between primary cup and compensating port.

Make check as follows:

1. Place power brake assembly in a vise so master cylinder is up. Remove master cylinder from front housing. Master cylinder push rod is now exposed.

NOTE: Master cylinder push rod must be pressed firmly to seat before gaging.

2. Place gage over piston rod in a position which will allow gage to be slipped to left or right without contacting studs.

The center section of gage has two levels. The piston rod end should always touch the longer section of gage which extends into front housing. The piston rod end should never touch the shorter section of gage. See Figure 50-69.

3. Any variation beyond these two limits must be compensated for by obtaining the service adjustable piston rod, Part Group 4.924, and adjusting the screw in end to match height of gage.

4. Replace hydraulic master cylinder on studs on front housing. Install nuts on studs and torque to 24 lb. ft.

57-5 INSTALLATION OF POWER BRAKE UNIT

1. Place power brake unit in position on dash and connect push rod clevis to brake pedal pin using retainer and washer.

2. Install four nuts on studs. Torque to 24 lb. ft.

3. Connect brake pipe to master cylinder.

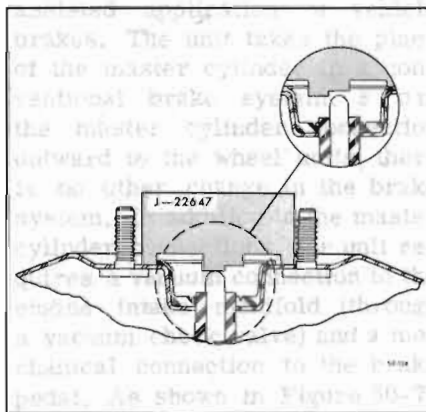

Figure 50-69—Gaging Master Cylinder Push Rod

4. Connect vacuum hose to check valve on power brake housing.

5. Bleed hydraulic system according to procedure in Section A, paragraph 56-2.

6. After bleeding, bring fluid level to no more than 1/8" below top of reservoir openings and install reservoir cover and diaphragm.

NOTE: When replacing unit on vehicle, start engine and allow vacuum to build up before applying brake.

7. Check pedal for full return and check stop light switch adjustment as described in Section A, paragraph 50-2 (b).

NOTE: On cars equipped with disc brakes, do not move car until firm brake pedal is obtained.

57-6 TESTING OF POWER BRAKE UNIT

1. Road test brakes by making a brake application at about 20 MPH to determine if vehicle stops evenly and quickly. If pedal has a spongy feel when applying brakes, air may be present in hydraulic system. Bleed system as described in Section A, paragraph 56-2.

2. With engine stopped and transmission in neutral, apply brakes several times to deplete all vacuum reserve in system. Depress brake pedal, hold light-foot pressure on pedal and start engine. If vacuum system is operating, pedal will tend to fall away under foot pressure and less pressure will be required to hold pedal in applied position. If no action is felt, vacuum system is not functioning.

3. Stop engine. Again deplete all vacuum reserve in system. Depress brake pedal and hold foot pressure on pedal. If pedal gradually falls away under foot pressure, hydraulic system is leaking internally or externally.

4. If brake pedal travels to within one inch of toeboard, brake shoes require adjustment or relining.

5. Start engine with brakes off and transmission in neutral. Run engine to medium speed and turn off ignition. Immediately close throttle. This builds up vacuum. Wait no less than 90 seconds, then try brake action. If not vacuum-assisted for two or more applications, vacuum check valve is faulty or there is a leak in vacuum system.

DIVISION IV

TROUBLE DIAGNOSIS

59-5 POWER BRAKE UNIT TROUBLE DIAGNOSIS

The same types of brake trouble are encountered with power brakes as with standard brakes. Before checking power brake system for source of trouble, refer to trouble diagnosis of standard brakes in Section A, Division IV. After these possible causes have been eliminated, check for cause as outlined below:

a. Hard Pedal

1. Vacuum failure due to:

a. Faulty vacuum check valve

b. Collapsed vacuum hose to manifold

c. Plugged or loose vacuum fittings

2. Binding pedal mechanism

3. Power brake unit trouble

a. Jammed air valve

b. Vacuum leaks in unit caused by faulty air valve seal or support plate seal. Also, a damaged floating control valve, bad seal of master cylinder or power cylinder mounting studs in housings, bad seal on master cylinder push rod or a bad seal of diaphragm bead between housings or at power piston. It is possible to have faulty vacuum check valve grommet.

c. Defective rolling diaphragm

d. Restricted air filter elements

e. Worn or distorted reaction plate or levers.

f. Cracked or broken power piston or reaction retainer

g. Manual hydraulic master cylinder boot (without air holes) on power brake.

b. Grabby Brakes (Apparent Off-and-On Condition)

1. Power brake unit valve trouble

a. Sticking air valve

b. Restricted diaphragm passage

2. Reaction system

a. Dislodged reaction levers

b. Broken air valve spring

c. Worn or distorted levers or plates.

c. Pedal Goes Either to Floor or Almost to Floor

1. Fluid reservoir needs replenishing.

2. Power brake hydraulic leakage

a. Defective primary or secondary cups

b. Cracked master cylinder casting

c. Leaks at wheel cylinder, in pipes or connections

3. Faulty master cylinder check valve has permitted air to enter system causing spongy pedal.

d. Brakes Fail to Release

1. Faulty hydraulic check valve

2. Blocked passage in power piston

3. Air valve sticking shut

4. Broken piston return spring

5. Broken air valve spring

6. Tight pedal linkage

