

SECTION A

ALL SERIES—BRAKE DRUMS, SHOES AND LININGS ALL SERIES—HYDRAULIC WHEEL CYLINDERS ALL SERIES—PARKING BRAKE CABLES ALL SERIES—HYDRAULIC MASTER CYLINDER (MANUAL AND POWER) ALL SERIES—BRAKE PIPES AND HOSES

CONTENTS

Division	Paragraph	Subject	Page
I		SPECIFICATIONS AND ADJUSTMENTS	
	50-1	Brake Specifications	50-2
	50-2	Service Brake Adjustment	50-4
	50-3	Parking Brake Adjustment	50-4
II		DESCRIPTION AND OPERATION	
	50-4	Description of Brake Mechanism	50-5
	50-5	Operation of Brake Mechanism	50-20
III		SERVICE PROCEDURES	
	51-1	Replace or Reline Brake Shoes	50-20
	51-2	Repair Brake Lining	50-22
	51-3	Inspecting and Reconditioning Brake Drums	50-23
	51-4	Hydraulic Wheel Cylinder Overhaul	50-24
	54-1	Parking Brake Cable Replacement	50-24
	55-1	Hydraulic Master Cylinder Overhaul	50-25
	56-1	Replacing Brake Pipes and Hoses	50-29
	56-2	Filling, Bleeding and Flushing Brake System	50-29
IV		TROUBLE DIAGNOSIS	
	59-1	Inspecting and Testing Brakes	50-31
	59-2	Brake Trouble Indications	50-32

DIVISION I—SPECIFICATIONS AND ADJUSTMENTS

50-1 BRAKE SPECIFICATIONS

a. Tightening Specifications

Use a reliable torque wrench to tighten the parts listed, to insure proper tightness without straining or distorting parts. These specifications are for clean and lightly lubricated threads only; dry or dirty threads produce increased friction which prevents accurate measurement of tightness.

50-1 BRAKE SPECIFICATIONS (Cont'd)

Part	Location	Thread Size	Torque
Nut	Brake Cylinder and Pedal Mounting Bracket to Dash	3/8-16	24 lb. ft.
Nut	Push Rod Clevis Locking (43-44000)	3/8-24	14 lb. ft.
Nut	Brake Pedal Pivot Shaft to Mounting Bracket (45-46-48-49000 Auto. Trans)	5/16-18	150 lb. in.
Nut	Brake Pedal and Clutch Pedal Pivot Shaft to Mounting Bracket (43-44000) .	7/16-14	25 lb. ft.
Nut	Parking Brake Mounting to Dash	5/16-18	120 lb. in.
Screw	Parking Brake Mounting to Instrument Panel	1/4-20	8 lb. ft.
Nut	Parking Brake Front Cable to Equalizer	5/16-18	5 lb. ft.
Bolt	Wheel Cylinder to Backing Plate Mounting (43-44000)	1/4-20	120 lb. in.
Bolt	Wheel Cylinder to Backing Plate Mounting (45-46-48-49000)	5/16-18	200 lb. in.
Bolt & Nut	Front Brake Assembly and Steering Arm to Knuckle (43-44000)	1/2-20	85 lb. ft.
Bolt & Nut	Front Brake Assembly and Steering Arm to Knuckle (45-46-48-49000) . .	1/2-13	80 lb. ft.
Bolt	Front Brake Anchor Pin (43-44000)	1/2-20	93 lb. ft.
Bolt	Front Brake Anchor Pin (45-46-48-49000)	9/16-18	140 lb. ft.
Bolt & Nut	Rear Brake Assembly to Axle Housing	3/8-24	35 lb. ft.
Nut	Wheel and Tire Assembly to Drum (43-44000)	7/16-20	65 lb. ft.
Nut	Wheel and Tire Assembly to Drum (45-46-48-49000)	1/2-20	65 lb. ft.

b. General Specifications

Items	
Operating Mechanism, Service Brakes	Hydraulic
Parking Brakes	Lever and Cables
Operation of Service Brakes Independent of Parking Brakes	Yes
Wheels Braked, Service	Front and Rear
Parking	Rear Only
Approx. % of Total Braking Power on - Front Wheel Brakes (43-44000 except Sportwagon and G.S. 400)	59
Rear Wheel Brakes (43-44000 except Sportwagon and G.S. 400)	41
Front Wheel Brakes (44000 Sportwagon)	55.9
Rear Wheel Brakes (44000 Sportwagon)	44.1
Front Wheel Brakes (44000 G.S. 400)	62.4
Rear Wheel Brakes (44000 G.S. 400)	37.6
Front Wheel Brakes (45-46-48000)	58.5
Rear Wheel Brakes (45-46-48000)	41.5
Front Wheel Brakes (49000 First Type)	56.0
Front Wheel Brakes (49000 Second Type)	61.5
Rear Wheel Brakes (49000 First Type)	44.0
Rear Wheel Brakes (49000 Second Type)	38.5
Brake Pedal Height Adjustment	None
Static Pressure in Hydraulic System when Brakes are Released (Drum Brakes)	8 to 16 lbs.
Number of Brake Shoes at Each Wheel	2
Brake Type	Self-Energizing-Servo
Brake Shoe Lining Type	1 pc., Molded-Riveted
Brake Drum Type, Front (44000 Sportwagon, 44000 G.S. 400, 46-48, 49000)	Finned Aluminum with Cast Iron Liner
Front (43-44000 except Sportwagon and G.S. 400, 45000 Series)	Finned Cast Iron
Rear (All Series)	Finned Cast Iron
Master Cylinder Piston Diameter, Drum Brakes	1"
Disc Brakes	1-1/8"
Wheel Cylinder Size Front (43-44000)	1-1/8"
Rear (43-44000 Except Sportwagon and G.S. 400)	15/16"
Rear (44000 Sportwagon)	1"
Rear (44000 G.S. 400)	7/8"
Front (49000 First Type)	1-1/8"
Front (45-46-48000, 49000 Second Type)	1-3/16"
Rear (45-46-48000)	1"
Rear (49000 First and Second Type)	15/16"

b. General Specifications (Cont'd)

	Items	
Approved Hydraulic Brake Fluid	GM or Delco Supreme No. 11 or Equivalent	
Fluid Level, Below Lip of Filler Opening	No More Than 1/8"	
Brake Drum Inside Diameter, New (43-44000)	9.495" to 9.505"	
(45-46-48-49000)	11.997" to 12.022"	
Brake Shoe Lining Length x Width		
43-44000 Front and Sportwagon Rear	Primary 7.65" x 2.50"	
	Secondary 9.92" x 2.50"	
43-44000 Rear (except Sportwagon)	Primary 7.65" x 2.00"	
	Secondary 9.92" x 2.00"	
45-46-48-49000 Front	Primary 9.90" x 2.25"	
	Secondary 12.85" x 2.25"	
45-46-48-49000 Rear	Primary 9.90" x 2.00"	
	Secondary 12.85" x 2.00"	
Brake Drum Rebore, Max. Allowable Inside Diameter (43-44000)	9.565"	
(45-46-48-49000)	12.080"	
Max. Allowable Taper, Before Rebore (43-44000)003"	
(45-46-48-49000)005"	
Max. Allowable Out-of-Round, Before Rebore (43-44000)006"	
(45-46-48-49000)010"	
Max. Allowable Out-Of-Balance of Drum (43-44000)	2 oz. in.	
(45-46-48-49000)	3 oz. in.	
Max. Allowable Space Between Lining and Shoe rim after Riveting005"	

50-2 BRAKE ADJUSTMENT

a. Preliminary Checks

1. Depress brake pedal firmly. If pedal travels to within 2-1/4 inches of toeboard on manual brake equipped car or 1-1/2 inches of toeboard on power brake equipped car and pedal has hard feel, brake shoes require adjustment or relining. However, if pedal has a spongy feel, brake system needs bleeding.
2. Remove one front wheel with hub and drum assembly. Inspect brake lining. If lining is worn nearly to rivets, reline brakes (par. 51-1).
3. Check fluid level in master cylinder reservoir and add fluid if necessary (par. 56-2).
4. Fully release parking brake and place transmission in neutral.
5. Pull on both ends of rear brake cable a number of times to make sure that cables operate rear brake shoes freely and do not bind in conduits. Check for free movement of cable in brake cable sheathing and check brake cable spring for tension. Replace cable assembly if spring is weak or broken.

b. Pedal Height and Stop Light Switch Adjustment

NOTE: Brake pedal height cannot be adjusted in either manual or power brake cars. In both manual and power brake cylinders, non-adjustable push rods connect directly to the brake pedals. Therefore, brake pedal height depends entirely on a stop in the master cylinder, which is also non-adjustable. No external brake pedal return spring is used, so pedal return depends entirely on a spring within the cylinder.

Make certain that the brake pedal returns completely when released slowly. If the pedal does not return freely, check all pivot points for binding or lack of lubrication. With pedal in fully released position, the stop light switch plunger should be fully depressed against an operating plate on the pedal shank. Adjust switch by turning in or out as necessary. See Figures 50-9, 10, 11, 12 or 13.

c. Adjustment at Wheels

1. Remove adjusting hole cover from brake backing plate. Install

J-21231 through adjusting hole to move actuator off adjusting screw. Use J-6166 to turn brake adjusting screw; expand brake shoes at each wheel until the wheel can just be turned by hand. The drag should be equal at all wheels.

2. Back off brake adjusting screw at each wheel 30 notches. If shoes still drag lightly on drum, back off adjusting screw one or two additional notches.

NOTE: Brakes should be free of drag when screw has been backed off approximately 12 notches. Heavy drag at this point indicates tight parking brake cables.

3. Install adjusting hole cover in brake backing plate when adjustment is completed.
4. Check parking brake adjustment as described in paragraph 50-3.
5. Road test car for service and parking brake performance. (Division IV).

50-3 PARKING BRAKE ADJUSTMENT

Adjustment of parking brake cable is necessary whenever the rear

brake cables have been disconnected or when cables have been stretched through extended use. Need for parking brake adjustment is indicated if the service brake operates with good reserve, but the parking brake pedal can be depressed more than eight ratchet clicks under heavy foot pressure.

After making certain that service brakes are in good adjustment, adjust parking brake mechanism as follows:

1. Depress parking brake pedal exactly three ratchet clicks.
2. Loosen jam nut located at rear of equalizer adjusting nut. See Figures 50-3, 4 or 5. Then tighten adjusting nut until rear wheels can just be turned rearward using two hands but are locked when forward rotation is attempted.
3. Release parking brake ratchet one click; at this two-click engagement, the rear wheels should rotate forward with a light drag and rearward freely.
4. Release mechanism one more ratchet click. At a one-click engagement, as well as with mechanism totally disengaged, rear wheels should turn freely in either direction.

NOTE: It is very important that parking brake cables are not adjusted too tightly to cause brake drag. With automatic brake adjusters, a tight cable causes brake drag and also positions the secondary brake shoe, hence the adjuster lever, so that it continues to adjust to compensate for wear caused by the drag. The result is a cycle of wear and adjustment that can wear out linings very rapidly.

DIVISION II DESCRIPTION AND OPERATION

50-4 DESCRIPTION OF BRAKE MECHANISM

The brake mechanism includes a

brake drum and a brake assembly at each wheel and two separate and independent control systems for applying the brakes--

- (1) Parking brake control system
- (2) Service brake control system with self-adjusting mechanism.

a. Wheel Brake Assemblies

Enclosing each wheel brake assembly is a brake drum which consists of a cast iron rim fused to a pressed steel disk. At all four wheels, the rims are finned for external heat dissipation. The cast iron rim provides an ideal braking surface which increases brake lining life.

Front brake drums on the 44000 Sportwagon and GS 400, 46-48-49000 Series are cast aluminum alloy with a cast iron liner. The aluminum section has ribs and fins for heat dissipation while the cast iron liner provides the best braking surface.

The brake assembly at each wheel uses a primary (front) and secondary (rear) brake shoe of welded steel construction. One-piece molded linings are attached to the brake shoes by rivets. The primary shoe lining is shorter than the secondary shoe lining and is of different composition; therefore, the two shoes are not interchangeable. See Figure 50-1.

Each brake shoe is held against

the backing plate by a hold-down spring, pin and cup which allows free movement of the shoe. The notched upper end of each shoe is held against the single anchor pin by a heavy coil spring. An adjusting screw and spring connects the lower ends of both shoes together and provides adjustment for clearance with the brake drum. There is no anchor pin adjustment as the pins are fixed in the backing plates.

A hydraulic wheel cylinder mounted on the backing plate between the upper ends of the brake shoes forces the shoes against the brake drum when the service brakes are applied. On rear wheels only, a lever mounted on each secondary shoe and connected to the primary shoe by a strut is used for applying the shoes when used as parking brakes. See Figure 50-2.

When the brake shoes contact the rotating drum, in either direction of car travel, they move with the drum until one shoe is stopped by the anchor pin and the other shoe is stopped through the connecting adjusting screw. Frictional force between drum and shoe lining tries to rotate each shoe outward around its anchor point, but the drum itself prevents this rotation; consequently, the shoes are forced more strongly against the drum than the applying force is pushing them. See Figure 50-1. It is also evident that the force applied by the drum to one shoe

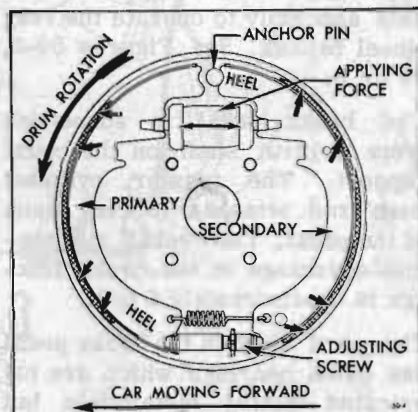

Figure 50-1—Brake Shoe Action

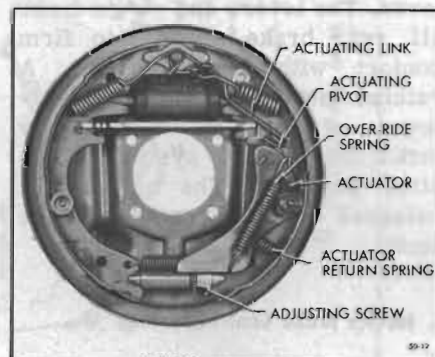

Figure 50-2—Left Rear Wheel Brake Assembly

is imparted to the other shoe through the connecting adjusting screw.

Utilization of the frictional force to increase the pressure of shoes against the drum is called self-energizing action. Utilization of force in one shoe to apply the opposite shoe is called servo action. The self-energizing servo action of Buick brakes provides powerful braking action with relatively light pedal pressure.

b. Parking Brake Control System

The parking brake control system, which applies only the rear wheel brakes, uses a foot-operated lever, cables and brake shoe levers and struts. By means of an equalizer, the front parking brake cable is connected to the forward portion of a center cable. See Figures 50-3, 4 or 5. This center cable is routed rearward from the equalizer through retaining guides which attach to right and left side frame rails. The center cable attached at either end to a rear cable assembly. Each rear cable connects to the free lower end of a brake shoe lever. These levers (one in each rear brake shoe assembly) pivot on the secondary shoes. Struts are mounted between the brake shoe levers and the primary shoes. See Figure 50-2.

When the foot-operated lever is depressed, the cables apply an equal pull to each brake shoe lever. The levers and struts force all rear brake shoes into firm contact with brake drums. A ratchet mechanism on the pedal-lever assembly automatically locks the control system in applied position. The brakes are released by pulling on the release knob.

c. Service Brake Control System

NOTE: See Section D for Delco Moraine Power Brakes

and Section E for Bendix Power Brakes.

The regular foot-powered service brake control system is a pedal operated hydraulic system which applies the brakes at all four wheels with equalized pressure. The hydraulic system consists of one master cylinder connected by pipes and flexible hoses to a wheel cylinder mounted between the brake shoes at each wheel. The master cylinder, pipes, hoses and four wheel cylinders are filled with brake fluid. A 3/16" O.D. brake pipe connects the front portion of the master cylinder assembly to the front portion of a brake warning light switch and distributor assembly located on of the left frame rail. This switch provides a warning to the driver if one part of the hydraulic system fails (pressure to front and rear wheels is not equal). See Paragraph 120-12(b) for checking procedures for brake warning light switch. From the front portion of the distributor, two separate 3/16" O.D. brake pipes are routed to the front wheel brakes.

A 1/4" O.D. brake pipe connects the rear portion of the master cylinder assembly to the rear portion of the switch and distributor assembly. From the rear portion of the distributor, a 1/4" O.D. brake pipe extends to the rear frame area where a flexible hose connects to two 3/16" O.D. brake pipes attached to the rear axle assembly to operate the rear wheel brakes. See Figures 50-6, 7, or 8.

The brake pedal is suspended from a pivot shaft on the pedal support. The master cylinder push rod attaches to the shank of the pedal. The overall mechanical advantage in the brake linkage is approximately 6 to 1.

The pivot shaft in the brake pedal has nylon bearings which are lubricated during installation but do not require periodic lubrication. Whenever the linkage is dis-

assembled, however, all friction surfaces should be lightly coated with Lubriplate. Because there is no pedal stop, the pedal is stopped in the released position by contact of the push rod with the stop plate in the master cylinder.

A plunger type stop light switch, which operates mechanically, is mounted on a bracket just rearward of the brake pedal. When the brakes are fully released, the brake pedal bears against the plunger and depresses it in the "off" position. As the pedal arm moves forward during brake application, the spring-loaded plunger moves to the "on" position. See Figures 50-9, 10, 11, 12 or 13.

The master cylinder contains a fluid reservoir and a cylindrical pressure chamber in which force applied to the brake pedal is transmitted to the fluid which actuates the brake shoes. A breather port and compensating port permit passage of fluid between the pressure chamber and the fluid reservoir during certain operating conditions. A vented cover and flexible rubber diaphragm at the top of the master cylinder reservoir seal the hydraulic system from possible entrance of contamination, while at the same time permitting expansion or contraction of fluid within the reservoir without direct venting. In the pressure chambers, coil springs hold rubber primary cups against the end of the pistons. These cups and rubber secondary seals on the opposite end of the pistons prevent escape of fluid past the pistons. The piston is retained in the cylinder by a stop plate. A rubber boot is installed over this end of the cylinder to exclude foreign matter.

Each wheel cylinder contains two pistons and two rubber cups which are held in contact with the pistons by a central coil spring with

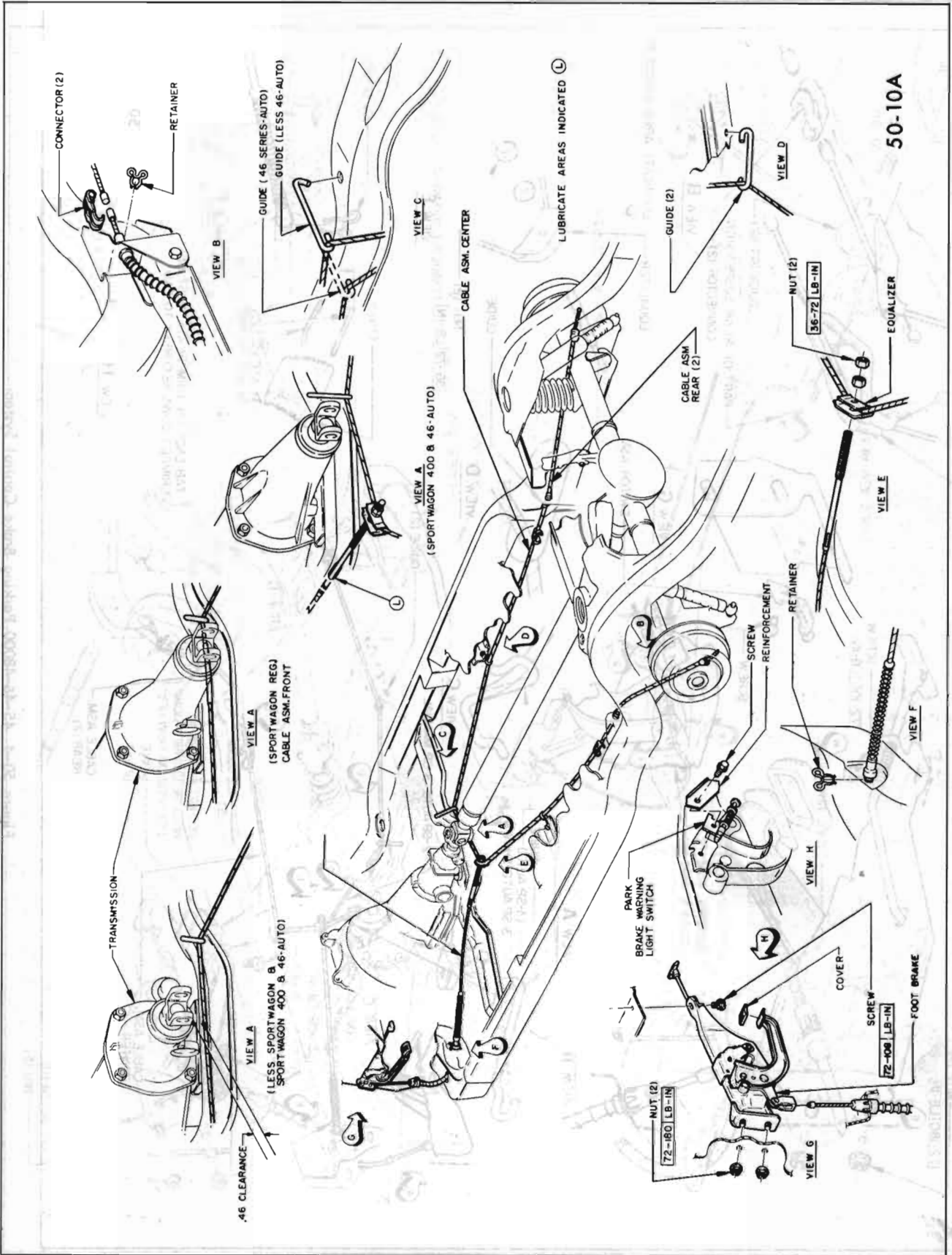

Figure 50-3 43-44000 Parking Brake Control System

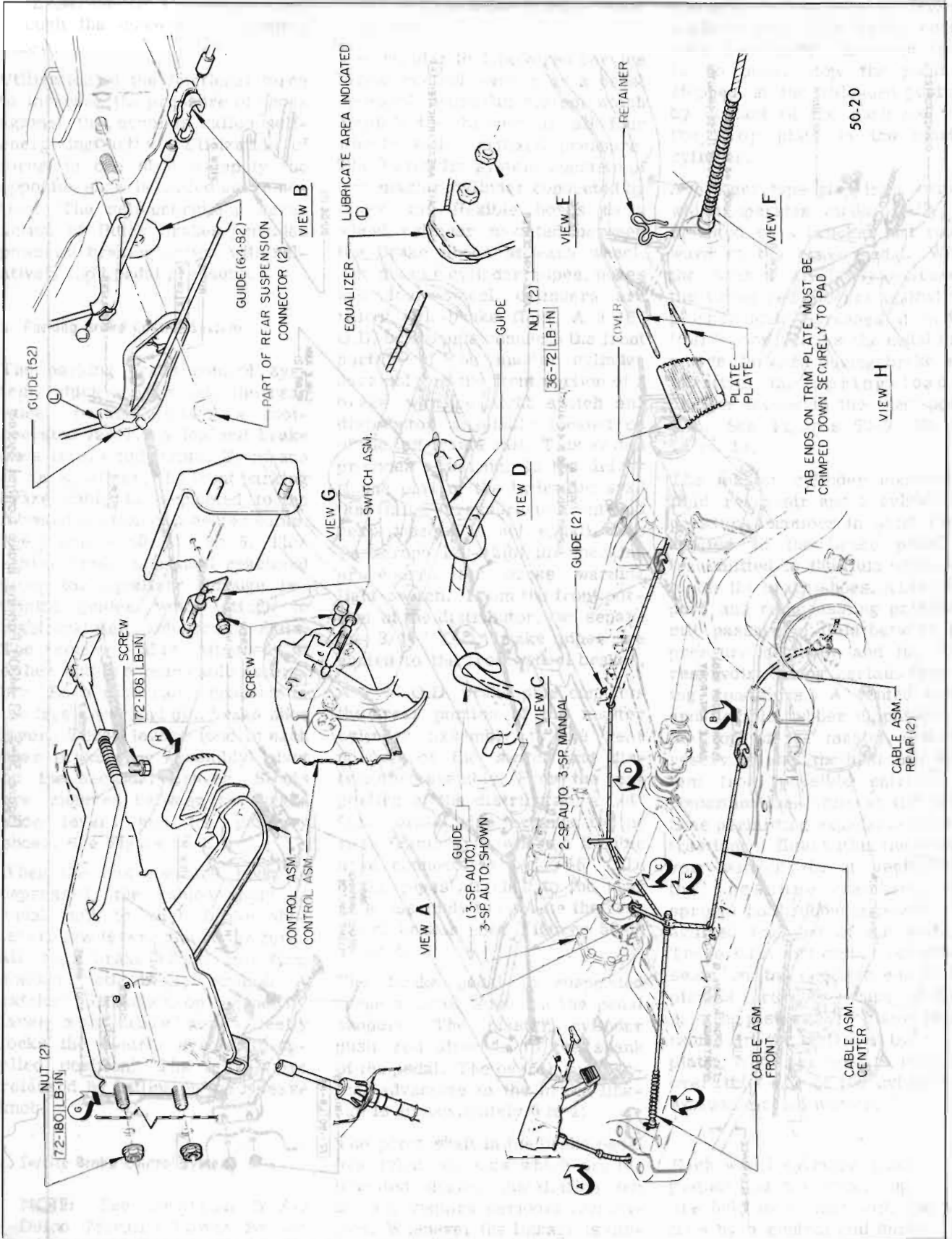

Figure 50-4 45-46-48000 Parking Brake Control System

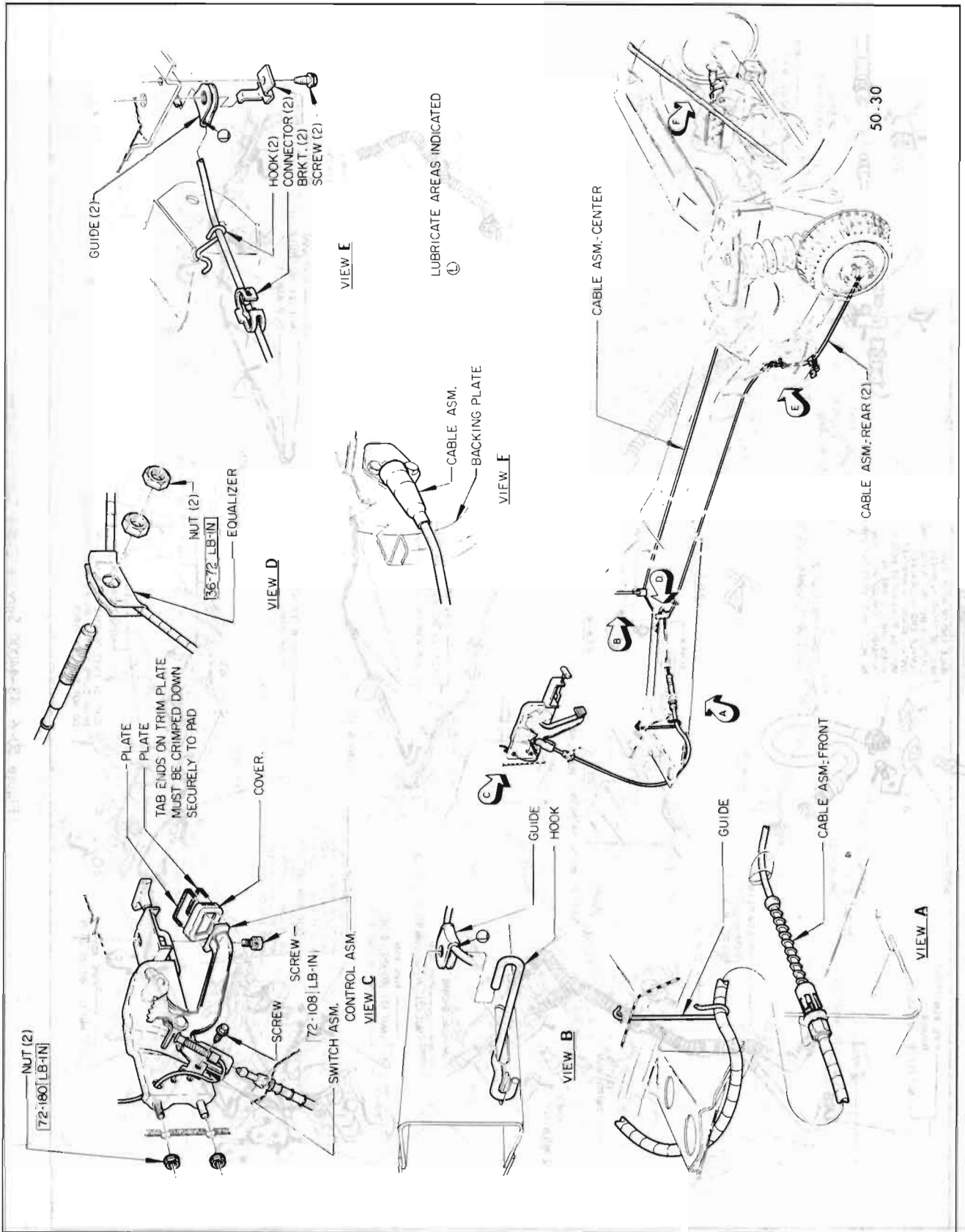

Figure 50-5 49000 Parking Brake Control System

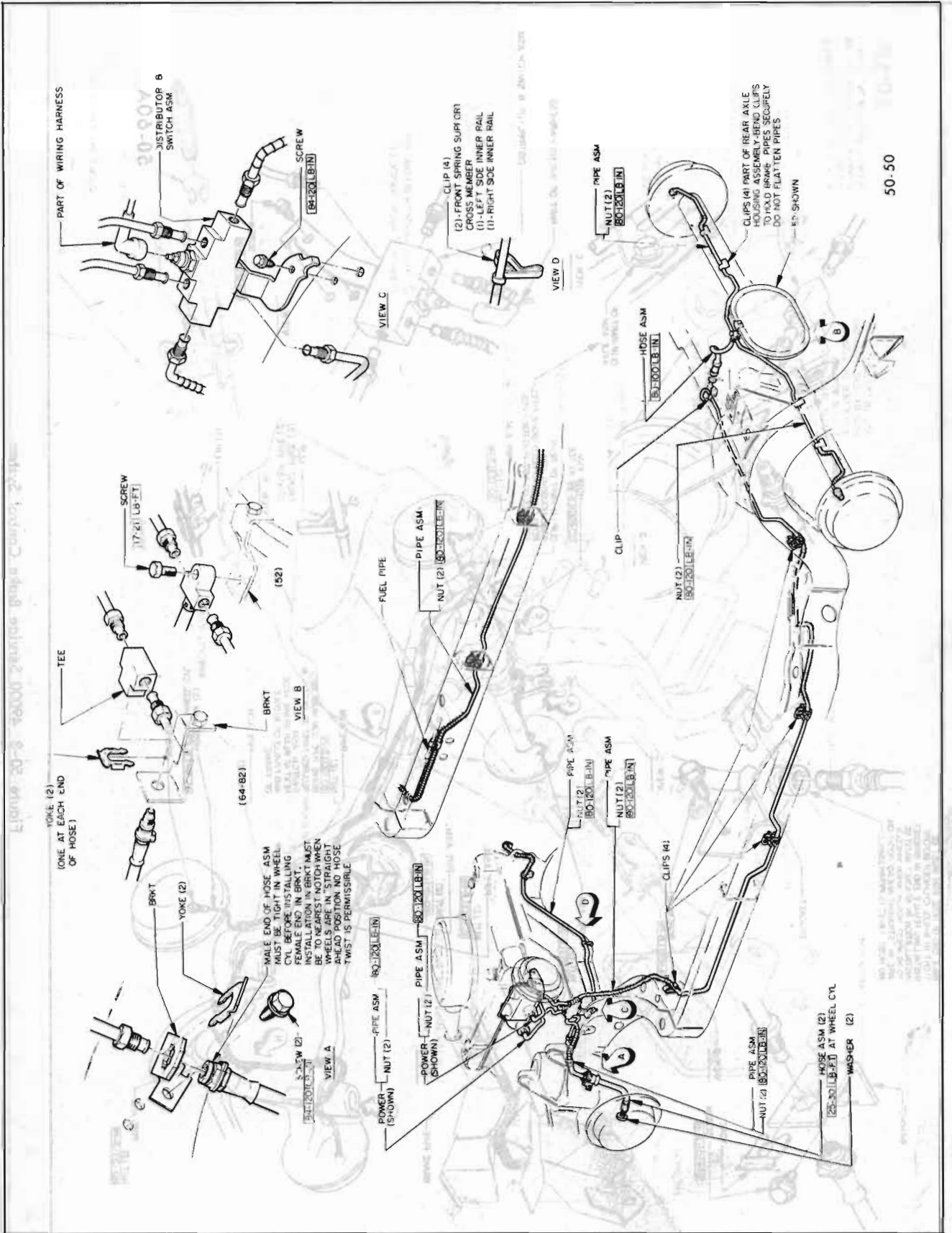

Figure 50-7 45-46-48000 Service Brake Control System

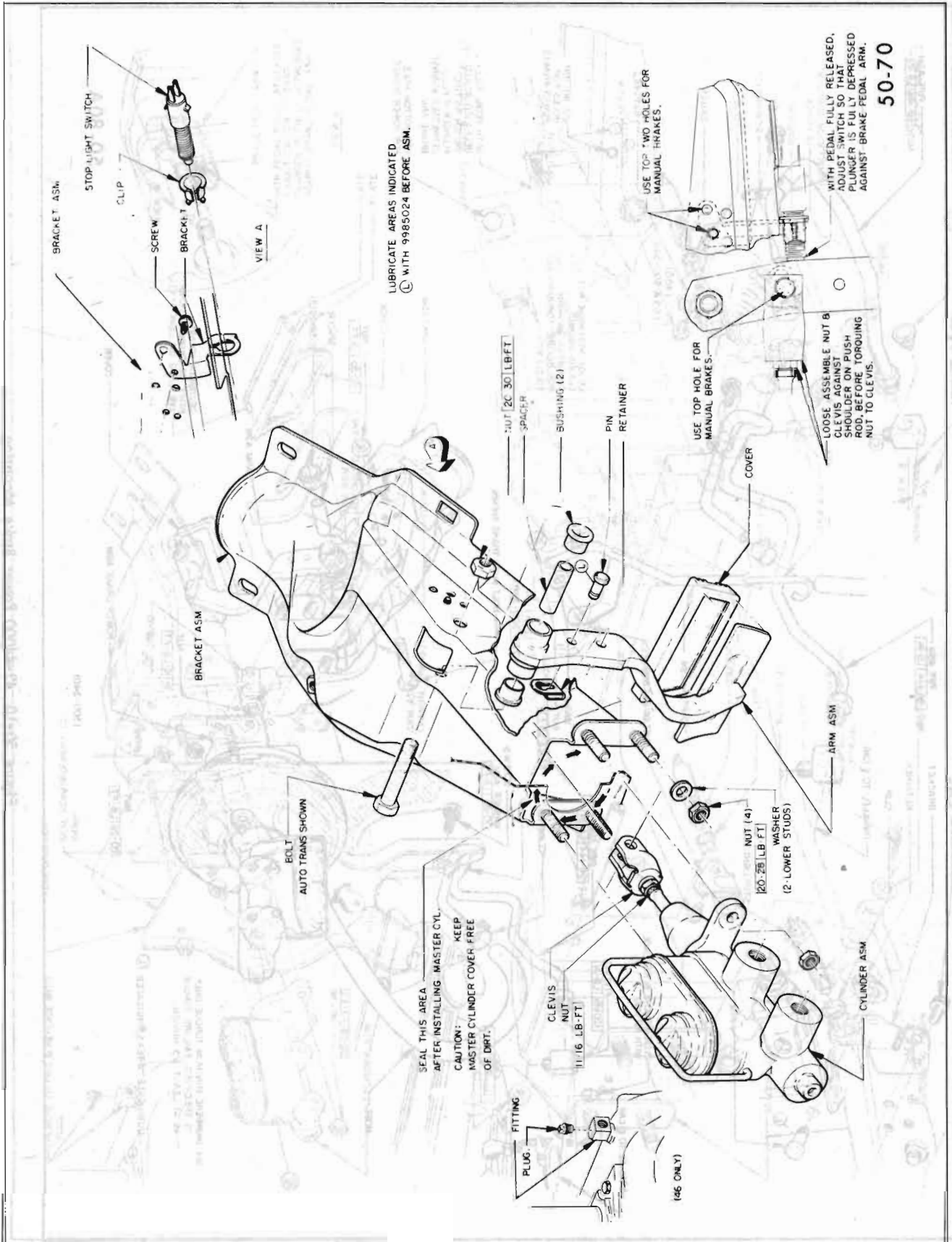

Figure 50-9 43-44000 Manual Brake Master Cylinder Mounting

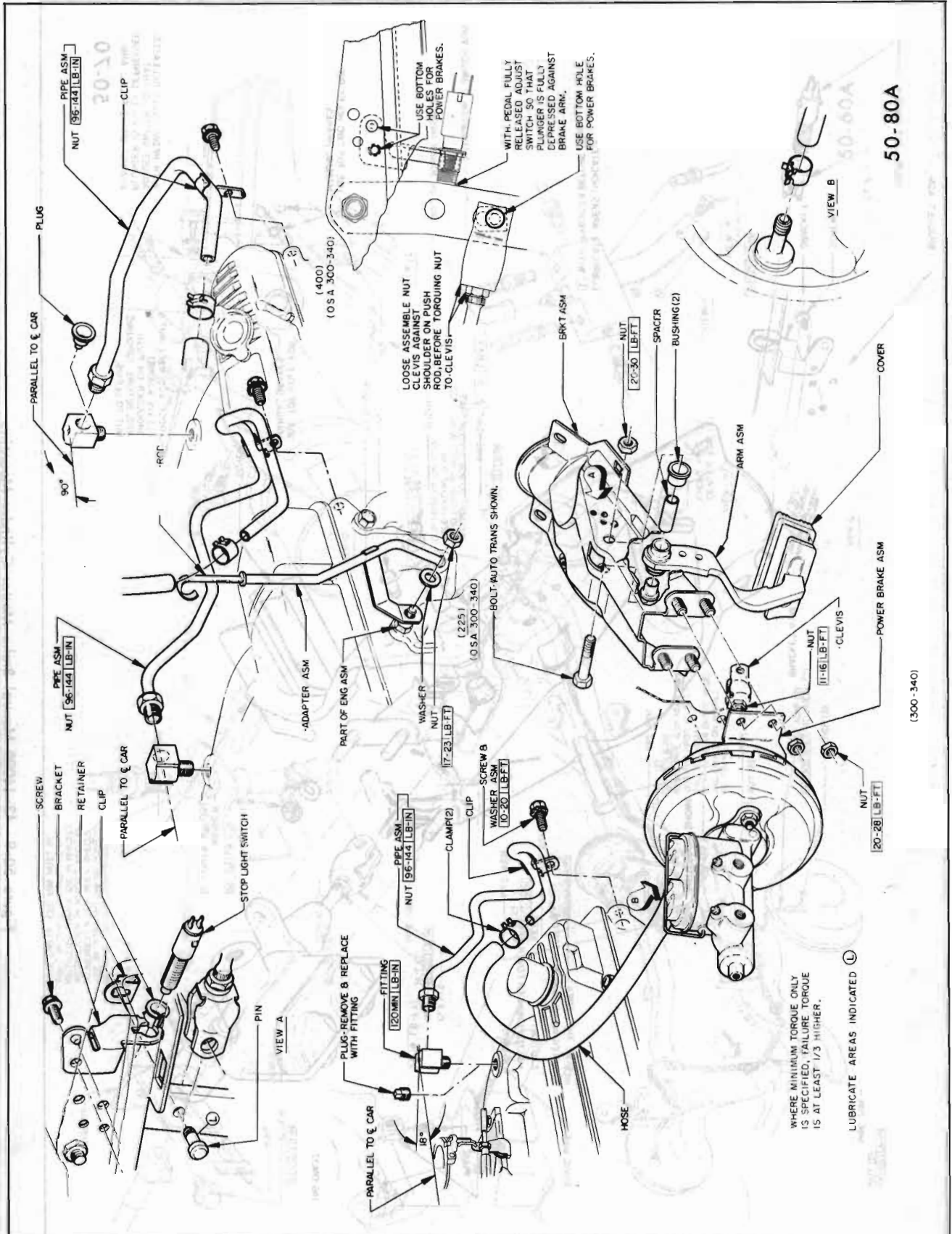
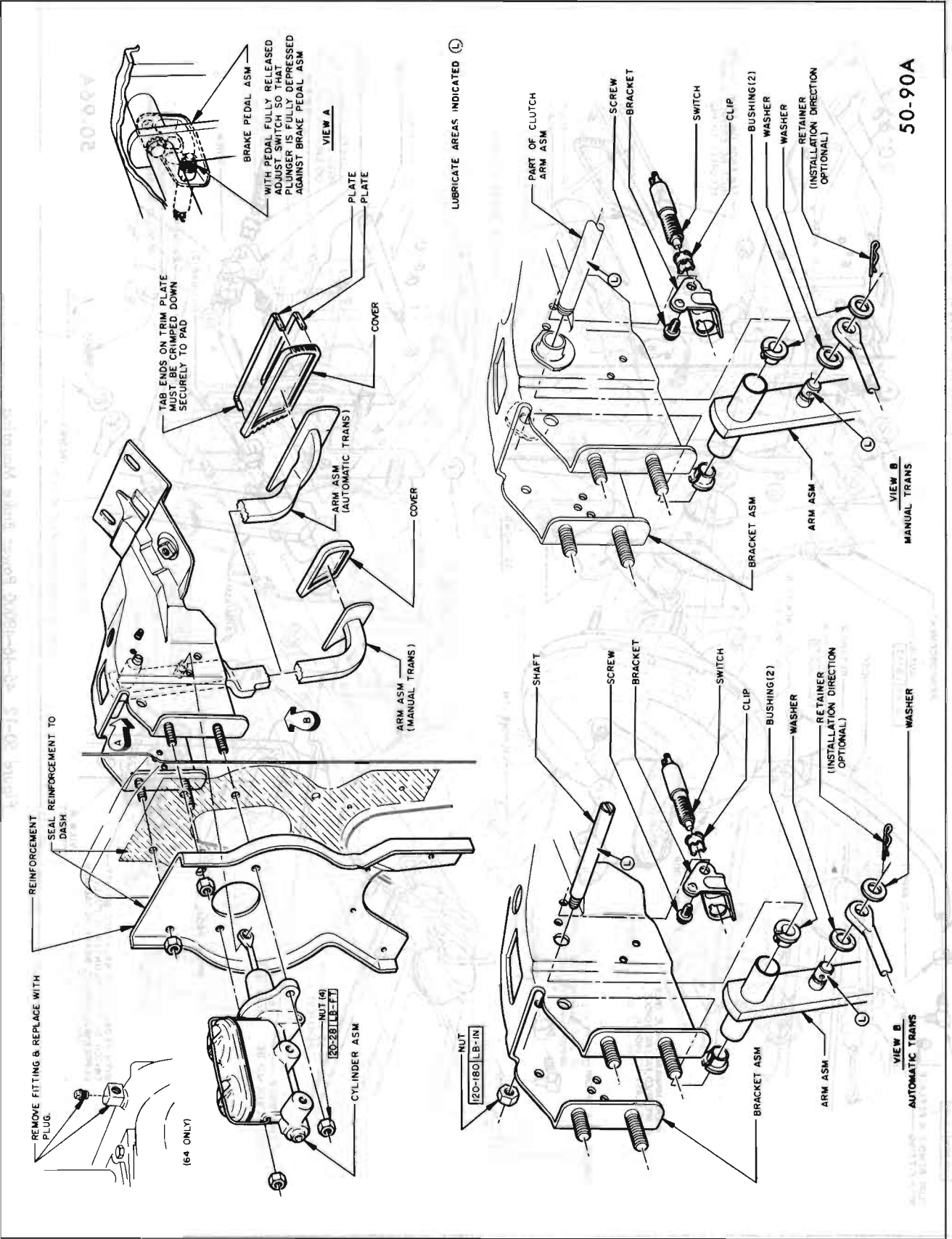

Figure 50-10 43-44000 Power Brake Mounting



50-90A

Figure 50-11 45-46000 Manual Brake Master Cylinder Mounting

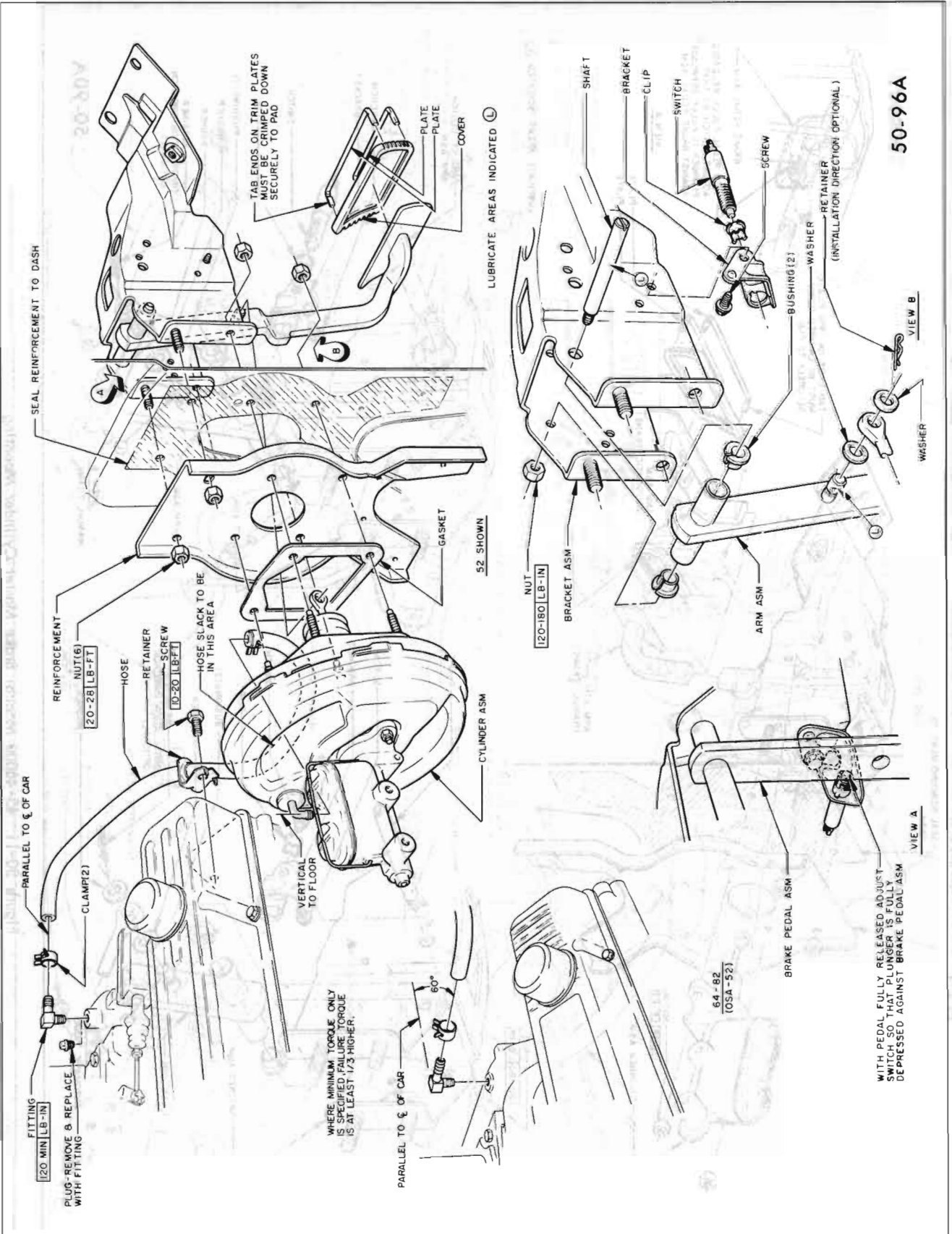

Figure 50-12 45-46-48000 Power Brake Mounting

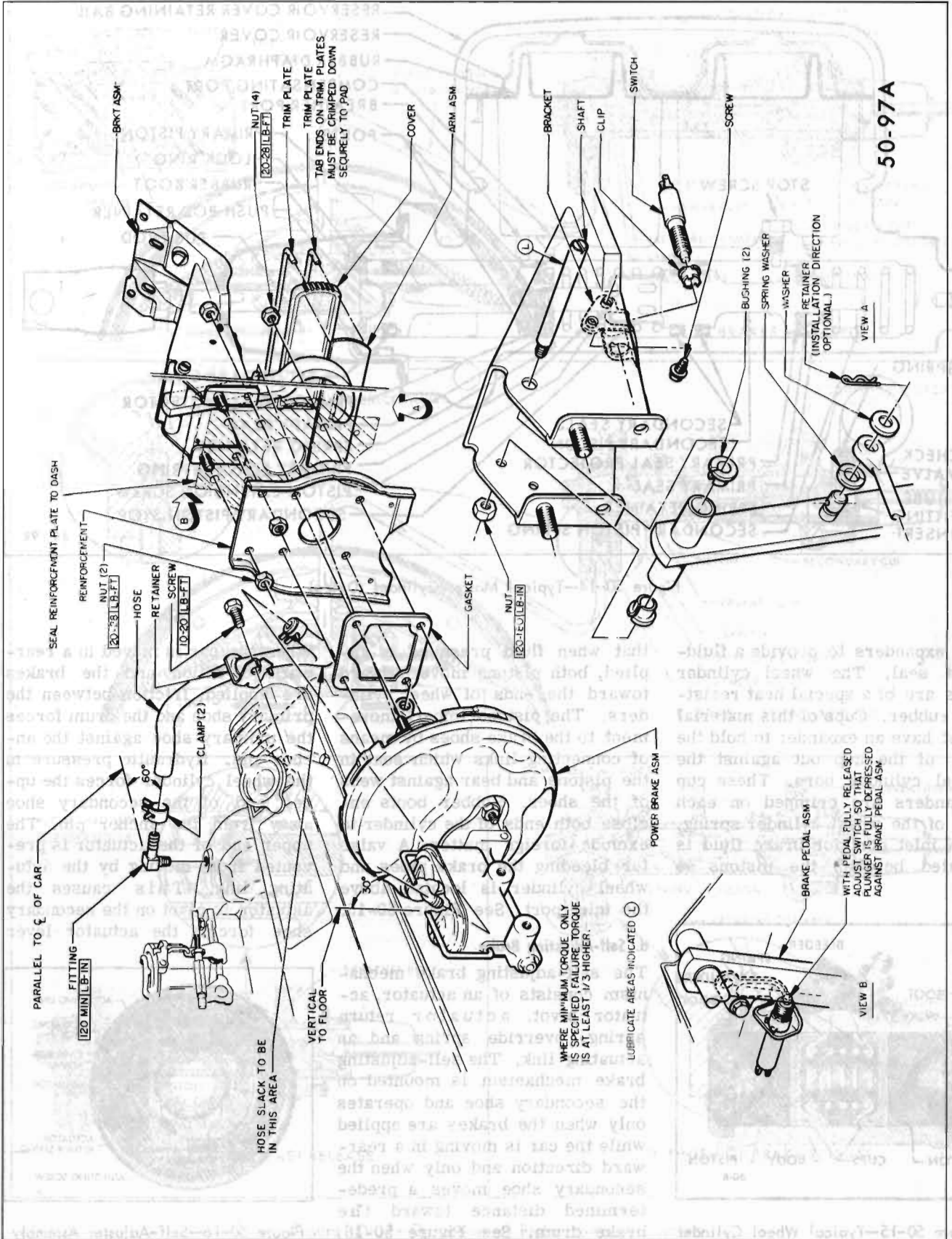

Figure 50-13 49000 Power Brake Mounting

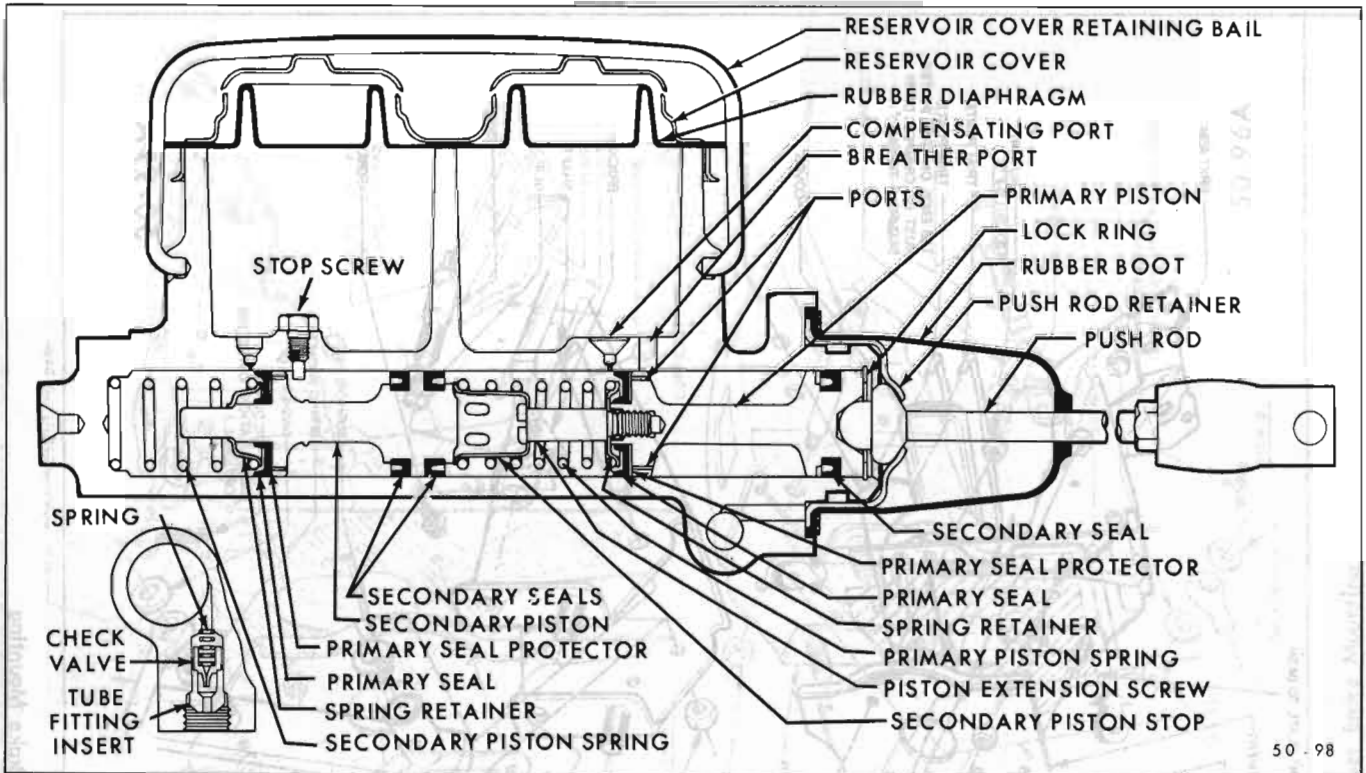

Figure 50-14—Typical Master Cylinder (Delco)

cup expanders to provide a fluid-tight seal. The wheel cylinder cups are of a special heat resisting rubber. Cups of this material must have an expander to hold the lips of the cup out against the wheel cylinder bore. These cup expanders are crimped on each end of the wheel cylinder spring. The inlet port for brake fluid is located between the pistons so

that when fluid pressure is applied, both pistons move outward toward the ends of wheel cylinders. The pistons impart movement to the brake shoes by means of connecting links which seat in the pistons and bear against webs of the shoes. Rubber boots enclose both ends of the cylinder to exclude foreign matter. A valve for bleeding the brake pipes and wheel cylinder is located above the inlet port. See Figure 50-15.

When the car is moved in a rearward direction and the brakes are applied, friction between the primary shoe and the drum forces the primary shoe against the anchor pin. Hydraulic pressure in the wheel cylinder forces the upper end of the secondary shoe away from the anchor pin. The upper end of the actuator is prevented from moving by the actuating link. This causes the actuator to pivot on the secondary shoe forcing the actuator lever

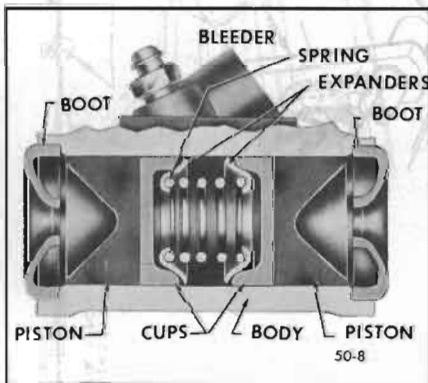

Figure 50-15—Typical Wheel Cylinder

d. Self-Adjusting Brake

The self-adjusting brake mechanism consists of an actuator, actuator pivot, actuator return spring, override spring and an actuating link. The self-adjusting brake mechanism is mounted on the secondary shoe and operates only when the brakes are applied while the car is moving in a rearward direction and only when the secondary shoe moves a predetermined distance toward the brake drum. See Figure 50-16.

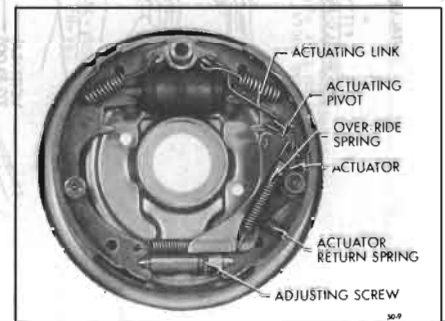

Figure 50-16—Self-Adjuster Assembly

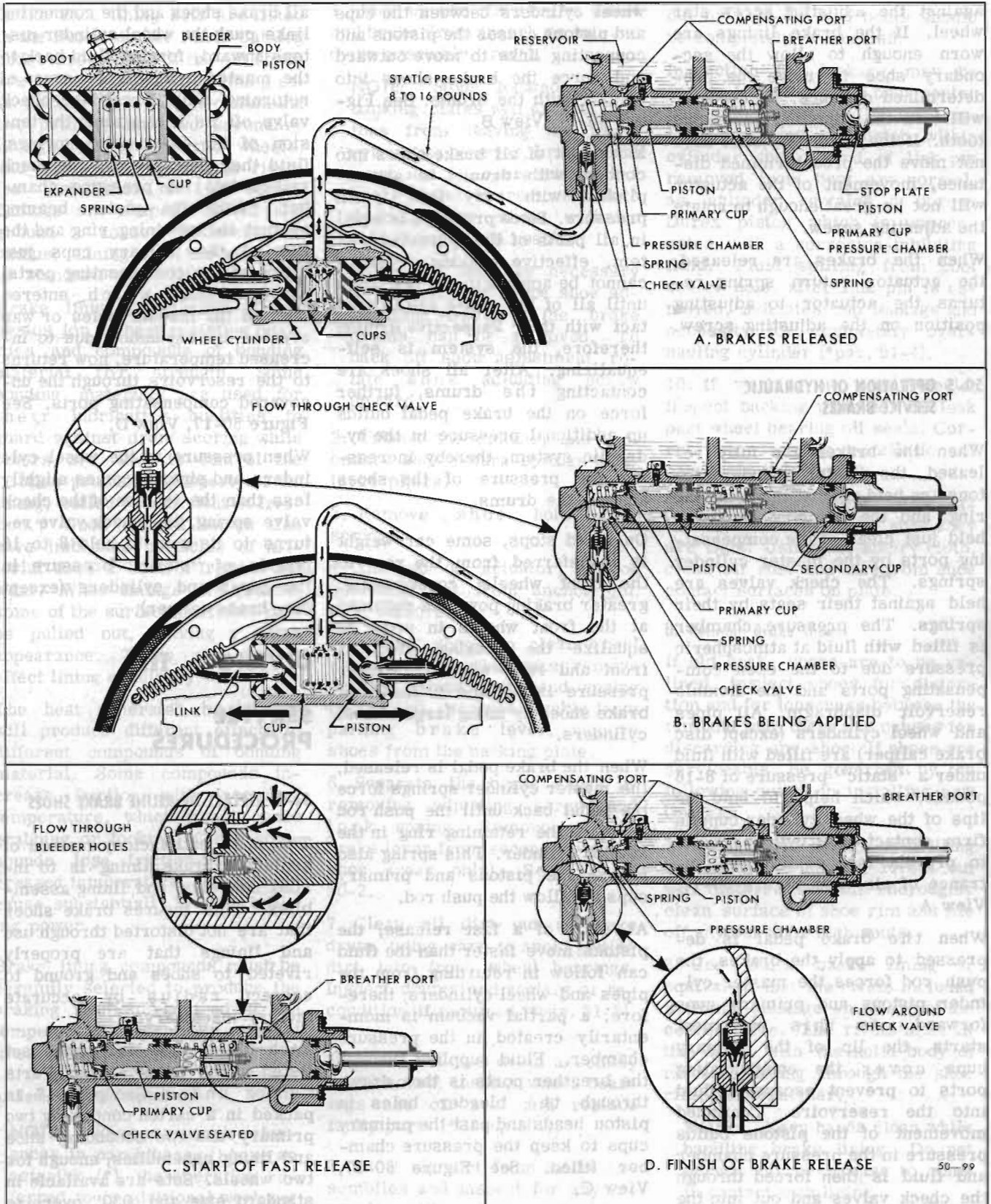

Figure 50-17—Operation of Brake Hydraulic System

against the adjusting screw star wheel. If the brake linings are worn enough to allow the secondary shoe to move the predetermined distance, the actuator will turn the adjusting screw one tooth. If the secondary shoe does not move the predetermined distance, movement of the actuator will not be great enough to rotate the adjusting screw.

When the brakes are released, the actuator return spring returns the actuator to adjusting position on the adjusting screw.

50-5 OPERATION OF HYDRAULIC SERVICE BRAKES

When the brakes are fully released, the master cylinder pistons are held against the retaining ring and the primary cups are held just clear of the compensating ports by the master cylinder springs. The check valves are held against their seats by their springs. The pressure chamber is filled with fluid at atmospheric pressure due to the open compensating ports and the flexible reservoir diaphragm. All pipes and wheel cylinders (except disc brake caliper) are filled with fluid under a "static" pressure of 8-16 pounds, which helps to hold the lips of the wheel cylinder cups in firm contact with cylinder walls to prevent loss of fluid or entrance of air. See Figure 50-17, View A.

When the brake pedal is depressed to apply the brakes, the push rod forces the master cylinder pistons and primary cups forward. As this movement starts, the lip of the primary cups cover the compensating ports to prevent escape of fluid into the reservoirs. Continued movement of the pistons builds pressure in the pressure chamber and fluid is then forced through the check valves and out into the pipes leading to the wheel cylinders. Fluid forced into the

wheel cylinders between the cups and pistons causes the pistons and connecting links to move outward and force the brake shoes into contact with the drums. See Figure 50-17, View B.

Movement of all brake shoes into contact with drums is accomplished with very light pedal pressure. Since pressure is equal in all parts of the hydraulic system, effective braking pressure cannot be applied to any one drum until all of the shoes are in contact with their respective drums; therefore, the system is self-equalizing. After all shoes are contacting the drums, further force on the brake pedal builds up additional pressure in the hydraulic system, thereby increasing the pressure of the shoes against the drums.

On rapid stops, some car weight is transferred from the rear to the front wheels; consequently, greater braking power is required at the front wheels in order to equalize the braking effect at front and rear wheels. Greater pressure is applied to the front brake shoes by using larger wheel cylinders.

When the brake pedal is released, the master cylinder springs force the pedal back until the push rod contacts the retaining ring in the master cylinder. This spring also forces the pistons and primary cups to follow the push rod.

At start of a fast release, the pistons move faster than the fluid can follow in returning from the pipes and wheel cylinders; therefore, a partial vacuum is momentarily created in the pressure chamber. Fluid supplied through the breather ports is then drawn through the bleeder holes in piston heads and past the primary cups to keep the pressure chamber filled. See Figure 50-17, View C.

As pressure drops in the master cylinder, the shoe springs retract

all brake shoes and the connecting links push the wheel cylinder pistons inward, forcing fluid back to the master cylinder. Pressure of returning fluid forces the check valve off its seat against the tension of the check valve springs; fluid then flows around the check valves into the pressure chamber. With the piston bearing against the retaining ring and the lips of the primary cups just clear of the compensating ports, excess fluid which entered through the bleeder holes or was created by expansion due to increased temperature, now returns to the reservoirs through the uncovered compensating ports. See Figure 50-17, View D.

When pressure in the wheel cylinders and pipes becomes slightly less than the tension of the check valve spring, the check valve returns to its seat to hold 8 to 16 pounds of "static" pressure in the pipes and cylinders (except disc brake caliper).

DIVISION III

SERVICE PROCEDURES

51-1 REPLACE OR RELINE BRAKE SHOES

The most satisfactory method of replacing brake lining is to install new shoe and lining assemblies. This insures brake shoes that are not distorted through use and linings that are properly riveted to shoes and ground to correct radius by accurate factory machinery.

Each brake shoe and lining set listed in the Buick Master Parts Catalog under Group 5.017 is packed in a carton containing two primary and two secondary shoe and lining assemblies, enough for two wheels. Sets are available in standard size and .030" oversize for use where brake drums have been rebored.

Brake shoe lining sets are listed in the Buick Master Parts Catalog under Group 5.018 if the old shoes are to be relined. Each lining set is packed in a carton containing two primary and two secondary linings, enough for two wheels, and packaged with enough rivets for installation on the shoes. Linings are shaped, drilled and ground to correct thickness and radius. Lining sets are available in standard and .030" oversize.

Brake linings are made of asbestos for its heat resisting qualities and compounds of bonding material for strength. Some bonding materials are used for their lubricating qualities to guard against drum scoring while others are used to control the friction producing property of the lining, called "coefficient of friction." Good molded linings also have imbedded particles of material used to control friction and wear. When linings are ground, some of the surface particles may be pulled out, leaving a pitted appearance. These pits do not affect lining efficiency.

The heat generated by friction will produce different effects in different compounds of bonding material. Some compounds increase friction with increased temperature, which might cause grabbing or locking. Other compounds lose friction with increased temperature, which might cause substantially lowered braking power.

Brake lining compounds must be carefully selected to produce the braking friction required at the temperatures normally attained in each vehicle application.

a. Removal and Inspection

NOTE: When paragraph references in parentheses () have an asterisk (*), the operation referred to is additional work not covered by the standard replacement operation.

1. Jack up car and remove wheel and brake drum (rear), or hub and drum assembly (front).

NOTE: Stops located on the backing plates will prevent pistons from leaving the wheel cylinders; however, brake pedal must not be operated while a brake drum is removed since damage to wheel cylinder rubber boots will result.

NOTE: It may be necessary to back off the brake shoe adjustment before the brake drums can be removed. To back off shoe adjustment, rotate shoe adjusting screw upward.

2. Unhook the primary and secondary shoe return springs using large pliers.

3. Remove shoe hold down springs.

4. Lift up on actuator, unhook actuating link from anchor pin, then remove.

5. Spread shoes to clear wheel cylinder connecting links, remove parking brake strut and spring (rear only), disconnect cable from parking brake lever, remove shoes from the backing plate.

6. Separate the brake shoes by removing adjusting screw and lock spring. Remove parking brake lever from secondary brake shoe (rear only). See Figure 50-2.

7. Clean all dirt out of brake drum, using care to avoid getting dirt into front wheel bearings. Inspect drums and replace or recondition if required (*par. 51-3).

If front hub and drum assembly is removed, inspect wheel bearings and oil seal and replace faulty parts (*Group 100).

8. Blow all dirt from brake assemblies and inspect for any unusual condition.

9. Wheel cylinders having torn,

cut or heat-cracked boots should be completely overhauled.

Inspection for leakage may be accomplished at the boot center hole after removal of link pin. Fluid coatings on piston within cylinder and on end of link pin removed from boot are normal, as cylinder contains a porous Durex piston which is impregnated with a corrosion-inhibiting fluid. Fluid spilling from boot center hole, after link pin is removed, indicates cup leakage and necessity for completely overhauling cylinder (*par. 51-4).

10. If working at rear wheels, inspect backing plate for oil leak past wheel bearing oil seals. Correct any leak by installation of new seals (*Group 40).

11. Check all backing plate attaching bolts to make sure they are tight. Using fine emery cloth, clean all rust and dirt from shoe contact surfaces on plate.

b. Relining Brake Shoes

If old brake shoes are to be relined, inspect shoes for distortion and for looseness between the rim and web; these are causes for discarding any shoe. If shoes are serviceable, be governed by the following points in installing new linings:

1. Remove old linings by drilling out rivets. Punching rivets out will distort shoe rim. Thoroughly clean surface of shoe rim and file off any burrs or high spots.

2. Use Buick brake lining or equivalent and the rivets included in lining package which are of the correct size. The rivets must fit the holes with the solid body of rivet extending through the shoe rim, but no farther.

NOTE: Keep hands clean while handling brake lining. Do not permit oil or grease to come in contact with lining.

3. Start riveting at center of shoe and lining and work toward the

ends. Use a roll set for riveting; a star set might split the tabular end and then the rivet would not fill the hole. The primary lining is shorter than secondary lining; therefore, the rivet holes at each end of the shoe rim are not used.

4. After riveting is completed, lining must seat snugly against shoe with no more than .005" separation midway between rivets. Check with a .004" (Go) and a .006" (No GO) feeler gauge.

c. Installation and Adjustment

1. On rear brakes only, lubricate fulcrum end of parking brake lever with Delco Brake Lubricant or equivalent, then attach lever to secondary shoe. Make sure that lever is free moving.

2. Connect brake shoes together with lock spring, then place adjusting screw in position.

NOTE: When installing adjusting screw, make sure right hand thread adjusting screw is on left side of car and left hand thread adjusting screw is on right side of car. Make certain star wheel lines up with adjusting hole in backing plate.

3. Lubricate shoe contact surfaces on backing plate with a thin coating of Delco Brake Lubricant or equivalent. On rear brakes, sparingly apply same lubricant where brake cable contacts backing plate.

4. Place brake shoes on backing plate, at the same time engaging shoes with wheel cylinder links. The primary shoe (short lining) goes toward front of car. On rear brakes, connect cable to parking brake lever and install strut and spring between lever and primary shoe.

5. Install actuator, actuator return spring and actuating link.

NOTE: If old brake shoe return springs are nicked, distorted or of doubtful strength

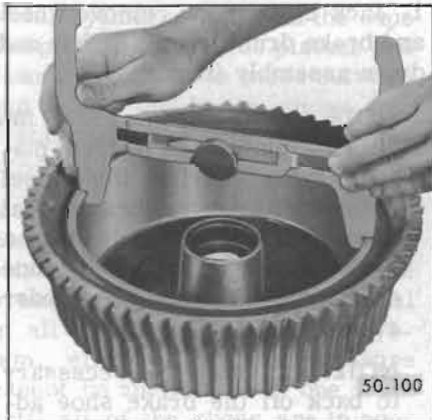

Figure 50-18—Measure Brake Drum I. D.

(discolored from heat), it is advisable to install new parts.

6. Install shoe hold down springs.

7. Install the primary and secondary shoe return springs using large pliers. Be careful not to distort springs.

8. Measure brake drum I.D. using inside caliper portion of Tool J-21177. Adjust brake shoes to dimension obtained on outside caliper portion of Tool J-21177.

9. Lubricate and adjust front wheel bearings. Install brake drums and wheels.

10. If any hydraulic connections were disturbed, bleed hydraulic system (par. 56-2). If new parts were installed in hydraulic system, flushing of hydraulic system is recommended.



Figure 50-19—Adjust Brake Shoes

11. Adjust parking brake as described in paragraph 50-3.

12. Inspect all brake pipes, hoses and connections for evidence of fluid leakage. Tighten any leaking connection. Then apply heavy pedal pressure to brake pedal and recheck connections.

13. Check fluid level in master cylinder and add fluid if necessary.

14. Check brake pedal for proper feel and for proper return.

15. Remove jacks and road test car for proper brake action (par. 59-1).

NOTE: Brakes must not be severely applied immediately after installation of new brake shoes or linings. Severe application may permanently damage new linings and may score brake drums. When linings are new, they must be given moderate use for several days until burnished.

51-2 REPAIR BRAKE LINING

This procedure is to be used when brake action is unequal, severe, hard, noisy or otherwise unsatisfactory and when brake linings have had little wear.

1. Check fluid in master cylinder and add fluid if necessary.

2. Check brake pedal for proper feel and for proper return.

3. Jack up car in a safe manner and remove all wheels.

4. Remove all brake drums.

NOTE: Brake pedal must not be operated while drums are removed.

5. Clean all dirt out of brake drums, using care to avoid getting dirt into front wheel bearings. Inspect drums and replace or recondition if required (par. 51-3).

6. Blow all dirt from brake assemblies, then inspect brake linings for uneven wear, oil soaking,

loose rivets or imbedded foreign particles. If linings are oil soaked, replacement is required.

7. If linings are otherwise serviceable, tighten or replace loose rivets and thoroughly clean all steel or other imbedded particles from surfaces and rivet counterbores of linings.

8. If brake linings at any wheel show a spotty wear pattern indicating uneven contact with brake drum, it is advisable to true up the linings with a light grinding cut, if suitable grinding equipment is available. If brake action is unequal, severe or hard, indicating that brake shoes are not centralized in drums, the grinder may also be used to correct this condition.

Grinding equipment which locates and swings off the wheel spindle or axle shaft may be used to grind shoes concentric with drums, or a bench mounted grinder may be used to grind shoes to the proper radius (.010" less than drum radius). The instructions of equipment manufacturer must be carefully followed.

9. Check all backing plate bolts to make sure they are tight.

10. Measure brake drum I.D. using inside caliper portion of Tool J-21177. Adjust brake shoes to dimension obtained, on outside caliper portion of Tool J-21177. See Figures 50-18 and 19.

11. Lubricate front wheel bearings, if necessary. Install front hub and drum assemblies and adjust wheel bearings. Install wheel and tire assemblies.

12. Remove jacks and road test car for proper brake action.

NOTE: Brakes must not be severely applied immediately after installation of reground brake shoes or linings. Severe application may permanently damage new linings and may

score brake drums. When linings are new, they must be given moderate use for several days until burnished.

51-3 INSPECTING AND RECONDITIONING BRAKE DRUMS

Whenever brake drums are removed, they should be thoroughly cleaned and inspected for cracks, scores, deep grooves and out-of-round. Any of these conditions must be corrected since they can impair the efficiency of brake operation and cause premature failure of other parts.

a. Cracked, Scored or Grooved Drum

WARNING: A cracked drum is unsafe for further service and must be replaced. Do not attempt to weld a cracked drum.

Smooth up any slight scores by polishing with fine emery cloth. Heavy or extensive scoring will cause excessive brake lining wear and it will probably be necessary to rebores in order to true up the braking surface.

If the brake linings are slightly worn and the drum is grooved, the drum should be rebored just enough to remove grooves and the ridges in the lining should be lightly removed with a lining grinder.

If brake linings are more than half worn but do not need replacement, the drum should be polished with fine emery cloth but should not be rebored. At this stage, eliminating the grooves in drum and smoothing the ridges on lining would necessitate removal of too much metal and lining, while if left alone, the grooves and ridges match and satisfactory service can be obtained.

If brake linings are to be replaced, a grooved drum should be rebored for use with oversize linings (subpar. c, following). A

grooved drum, if used with new lining, will not only wear the lining, but will make it difficult, if not impossible to obtain efficient brake performance.

b. Out-of-round or Tapered Drum

An out-of-round drum makes accurate brake shoe adjustment impossible and is likely to cause excessive wear of other parts of brake mechanism due to its eccentric action. An out-of-round drum can also cause severe and irregular tire tread wear.

A drum that is more than .006" (43-44000) or .010 (45-46-48-49000) out-of-round on the diameter is unfit for service and should be rebored (subpar. c, following). A drum that has more than .003" (43-44000) or .005" (45-46-48-49000) taper should be rebored. Out-of-round as well as taper and wear can be accurately measured with an inside micrometer fitted with proper extension rods.

When measuring a drum for out-of-round, taper and wear, take measurements at the open and closed edges of machined surface and at right angles to each other.

c. Reboring Brake Drum

If a drum is to be rebored, only enough metal should be removed to obtain a true, smooth braking surface. If a drum does not clean-up when rebored to a maximum diameter as shown in the general specification, par. 50-1, it must be replaced. Removal of more metal will affect dissipation of heat and may cause distortion of the drum.

A newly bored drum should always have center contact with the shoes on initial break-in, thus ensuring greater uniformity in brake performance with less danger of brake pulling. To get this desired position, the shoe radius should be .010" less than the

drum radius (or .020" less on the diameter). This fit may be accomplished by either grinding the shoes or boring the drums, whichever is more practical.

Fit between the brake shoes and the drum must always be the same on both sides of the car to get equal braking action.

Brake drums may be refinished either by turning or grinding. Best brake performance is obtained by turning drums with a very fine feed. Too coarse a feed will cause a condition on the car called "shoe slap" in which the shoes attempt to follow the spiral of cut, then snap back against the backing plate. Ground and polished drums do not wear in as readily as turned drums and are more likely to cause unequal braking when new. To insure maximum lining life, the refinished braking surface must be smooth and free from chatter or tool marks.

d. Brake Drum Balance

During manufacture, brake drums are balanced within two ounce inches (43-44000) and three ounce inches (45-46-48-49000) by fastening weights, as required, near the rim. These weights must not be removed.

After drums are rebored, or if difficulty is experienced in maintaining proper wheel balance, it is recommended that brake drums be checked for balance. Brake drums may be checked for balance on most off-the-car wheel balancers.

51-4 HYDRAULIC WHEEL CYLINDER OVERHAUL

NOTE: When overhauling or replacing 49000 Series wheel cylinders, be sure to install the correct repair kit or wheel cylinder. First type wheel cylinder size is 1-1/8", second type size is 1-3/16".

a. Removal of Brake Wheel Cylinder

1. Remove wheel, drum and brake shoes. Be careful not to get grease or dirt on brake lining.
2. Disconnect brake pipe or hose from wheel cylinder and cover opening with tape to prevent entrance of dirt. Remove wheel cylinder from backing plate.

b. Disassembly of Brake Wheel Cylinder

1. Pull boots from cylinder ends and discard boots.
2. Remove and discard pistons and cups.

c. Inspection of Brake Wheel Cylinder

1. Inspect cylinder bore for scoring or corrosion. It is best to replace a corroded cylinder.

NOTE: Staining is not to be confused with corrosion. Corrosion can be identified as pits or excessive roughness.

2. Polish any discolored or stained area with crocus cloth by revolving cylinder on cloth supported by a finger. Do not slide cloth in a lengthwise manner under pressure. Do not use any other form of abrasive or abrasive cloth.
3. Rinse cylinder in Declene or clean brake fluid.
4. Shake excess rinsing fluid from cylinder. Do not use a rag to dry cylinder, as lint from the rag cannot be kept from cylinder bore surfaces.

d. Assembly of Brake Wheel Cylinder

1. Lubricate cylinder bore and counterbore with clean brake fluid and insert spring-expander assembly.

2. Install new cups. (Be sure cups are lint and dirt free). Do not lubricate cups prior to assembly.

3. Install new Durex pistons in the "As Received" condition - do not lubricate pistons with brake fluid. Always use new Durex pistons to insure proper corrosion inhibiting properties.

4. Press new boots into cylinder counterbores by hand. Do not lubricate boots prior to assembly.

e. Installation of Brake Wheel Cylinder

1. Install wheel cylinder on brake backing plate and connect brake pipe or hose. Torque front wheel brake hose to wheel cylinder to 28 lb. ft. Torque rear wheel brake pipe to wheel cylinder to 100 lb. in.

2. Install brake shoes, drum and wheel; then flush and bleed hydraulic system (par. 56-2).

3. Adjust brakes (par. 50-2), then road test car for brake performance (Division IV).

54-1 PARKING BRAKE CABLE REPLACEMENT

a. Front Parking Brake Cable Replacement

1. Raise car.
2. Remove jam nut and adjusting nut from equalizer. See Figures 50-3, 4, and 5.
3. Remove retainer clip (all series except 49000) from rear portion of front cable at frame.
4. Using a pair of pliers, bend snap-in retainer fingers in, so that cable can be removed.
5. Disconnect front brake cable from parking brake pedal assembly. Remove front brake cable.

NOTE: On some models it may assist installation of new cable if a heavy cord is tied to either end of cable in order to guide new cable through proper routing.

6. Install cable by reversing removal procedure.
7. Adjust parking brake as detailed in par. 50-3.

b. Center Parking Brake Cable Replacement

1. Raise car.
2. Remove jam nut and adjusting nut from equalizer.
3. Unhook connector at each end and disengage hooks and guides.
4. Install new cable by reversing removal procedure.
5. Adjust parking brake as detailed in par. 50-3.

c. Rear Parking Brake Cable Replacement

1. Raise car.
2. Remove rear wheel and brake drum.
3. Loosen jam nut and adjusting nut at equalizer.
4. Disengage rear cable at connector.
5. Remove two bolts attaching cable assembly to backing plate.
6. Disengage cable at brake shoe operating lever.
7. Install new cable by reversing removal procedure.
8. Adjust parking brake as detailed in par. 50-3.

55-1 BRAKE MASTER CYLINDER OVERHAUL

The dual master cylinder is designed and built to satisfy individual brake system displacement

SERIES	BRAKE TYPE	MASTER CYLINDER CODE	SECONDARY PISTON IDENTIFICATION
43-44000	MANUAL-DRUM POWER-DRUM	CT	1-RING OR 1-GROOVE
43-44000	POWER-DISC	FR	3-RINGS OR 3-GROOVES
45-46000	MANUAL-DRUM	LX	3-RINGS OR 3-GROOVES
45-46-48-49000	POWER-DRUM	HU	PLAIN
45-46-49000	POWER-DISC	YM <small>50-102A</small>	2-RINGS OR 2-GROOVES

Figure 50-20—Brake Master Cylinder Identification

requirements for each car model. Therefore, it is necessary that the following basic rules be used when replacing either complete master cylinder assemblies or the component pistons of these assemblies.

The two-letter identification stamp on the end of the master cylinder indicates the displacement capabilities of that particular cylinder. See Figure 50-20. Master cylinders should only be replaced with another cylinder bearing the same two-letter identification. Bendix hydraulic master cylinders are used on some 45-46-48-49000 Series equipped with power brakes. These master cylinders can be identified by an external piston stop screw. See Figure 50-21.

The length of the component pistons in the master cylinders are critical factors in displacement capabilities of a particular master cylinder. These pistons are coded, using rings or grooves in the shank of the piston. It is mandatory that when pistons are replaced, the replacing piston must contain the same identification marks and the same contour at the push rod end as the piston which was removed.

Dual master cylinders, used with drum-type brakes, contain a rubber check valve and check valve

spring in each outlet boss. When the car is equipped with disc brakes on the front and drum brakes on the rear, the dual master cylinder will have a check valve and spring in the outlet boss for the rear brakes only. No check valve is required for disc brakes, and therefore, the outlet boss to the front brakes will not contain a check valve and spring.

a. Removal of Brake Master Cylinder

1. Disconnect brake pipes from master cylinder and tape end of pipes to prevent entrance of dirt.
2. (Manual brake only) Disconnect brake pedal from master cylinder push rod by removing retainer clip and clevis pin on 43-44000 series or retainer pin and washer on 45-46000 series. See Figure 50-9 or 11.
3. Remove two nuts holding master cylinder to dash or power cylinder and remove master cylinder from car. Be careful not to drip brake fluid on exterior paint.

b. Disassembly of Brake Master Cylinder

1. Clean outside of master cylinder thoroughly. Remove reservoir cover and diaphragm. Turn cylinder over and pump push rod

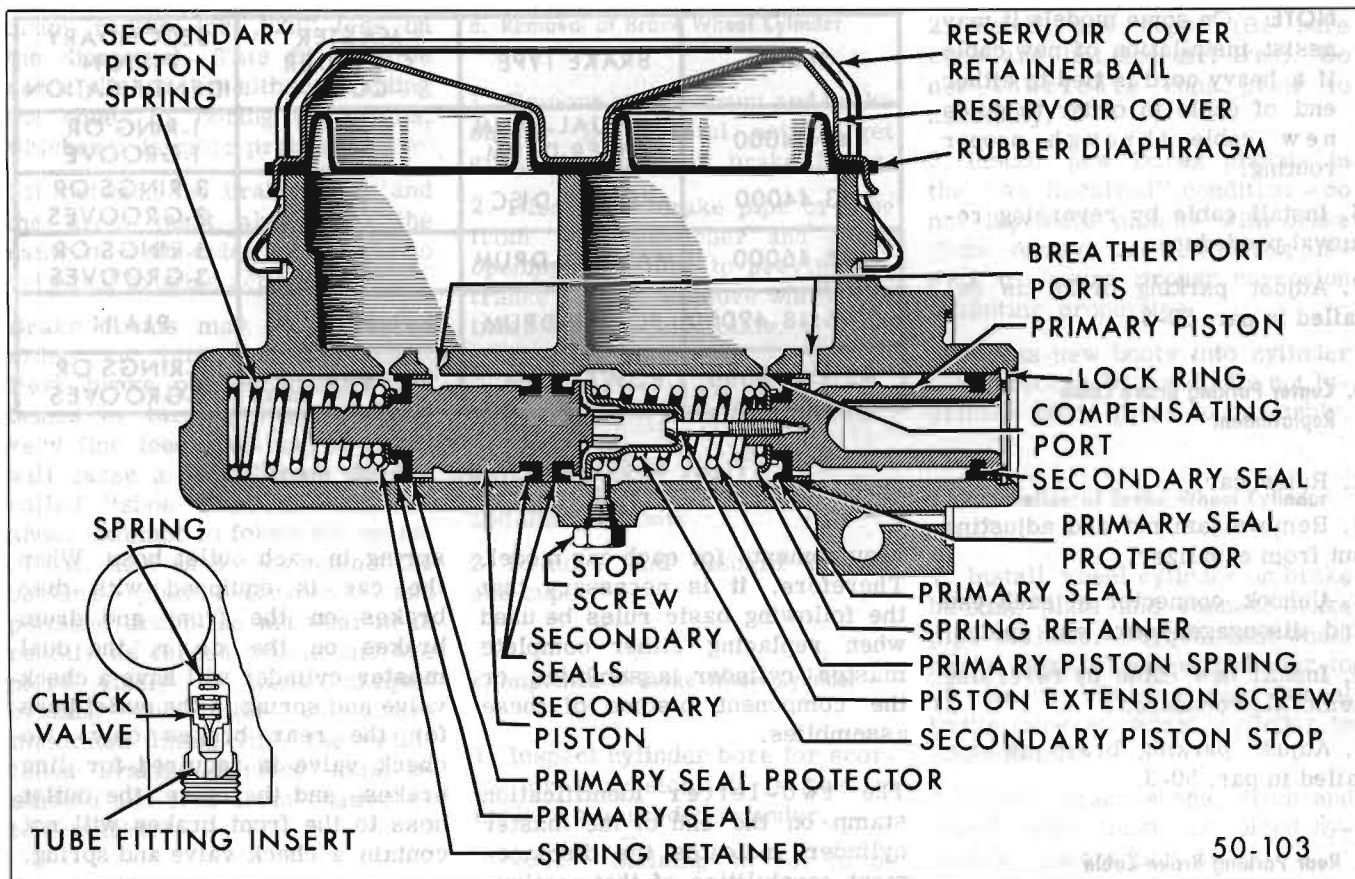

50-103

Figure 50-21—Bendix Hydraulic Master Cylinder

by hand to drain all brake fluid. Always discard used fluid.

2. (Manual brake only.) a new type of retained push rod is used on 1967 models equipped with manual brakes. Pull boot away from master cylinder to uncover push rod retainer. The retainer has a small, depressed tab in the side. This tab may be pried up to release retainer. This tab serves only to hold retainer and push rod on master cylinder, while it is being shipped. The tab does not have to be bent down again at re-assembly, because retainer is held in place between master cylinder and dash when master cylinder is bolted to car.

3. Depress piston and remove secondary piston stop bolt from bottom of front fluid reservoir (Delco Moraine) or exterior bottom of master cylinder (Bendix).

Remove seal ring from stop bolt (Bendix).

4. Place master cylinder in a vise so that lock ring can be removed from groove in the inside diameter of bore. Remove lock ring and primary piston assembly. Remove secondary piston, secondary piston spring and retainer by blowing air through the stop bolt hole (Delco Moraine) or using mechanical finger to grasp flange on end of piston (Bendix).

NOTE: If no air is available, a piece of wire may be used. Bend about one fourth inch (1/4") of one end into a right angle. Hook this end under edge of the secondary piston and pull it out.

5. Place master cylinder in vise, so that outlet holes are up. En-

large hole in tube fitting insert using a 13/64" drill. Tap a 1/4"-20 thread in insert. Place a heavy washer over outlet on master cylinder and thread a 1/4-20 x 3/4" screw into the insert. Tighten screw until insert is unseated. Remove insert, screw and washer.

6. Remove check valve and spring from cavity beneath tube fitting insert on those models not equipped with disc brakes.

7. Remove primary seal, primary seal protector and two secondary seals from secondary piston. Remove piston extension screw, which holds primary piston spring on primary piston. The spring retainer, primary seal, primary seal protector and secondary seal can now be removed from primary piston.

8. Use Declene or clean brake fluid to clean all metal brake



Figure 50-22—Remove Tube Seat

parts thoroughly. Immerse in cleaning fluid and brush with hair brush to remove foreign matter. Blow out all passages, orifices and valve holes. Air dry and place cleaned parts on clean paper or lint free clean cloth.

NOTE: Do not use anti-freeze alcohol, gasoline, kerosene or any other cleaning fluid that might contain even a trace of mineral oil.

NOTE: Dirt is the major cause of trouble and wear in service. be sure to keep parts clean until reassembly. Rewash at reassembly, if there is any occasion to doubt cleanliness.

c. Inspection of Brake Master Cylinder

Inspect cylinder bore for scoring or corrosion. It is best to replace a corroded cylinder.

NOTE: Staining is not to be confused with corrosion. Corrosion can be identified as pits or excessive roughness.

Polish any discolored or stained area with crocus cloth by revolving cylinder on cloth supported by a finger. Do not slide cloth in a lengthwise manner under pressure. Do not use any other form of abrasive or abrasive cloth.

Rinse cylinder in Declene or clean brake fluid.

Shake excess rinsing fluid from

cylinder. Do not use a rag to dry cylinder, as lint from rag cannot be kept from cylinder bore surfaces.

Make certain that compensating port in cylinder is clear; however, do not run a wire through the port as this may leave a burr which will cut a groove in primary cup.

If scratches or corroded spots are too deep to be polished satisfactorily, the cylinder should be replaced since honing is not recommended and oversize pistons and cups are not furnished for service.

The master cylinder bore has a hard, highly polished "bearingized" surface produced by diamond boring followed by rolling under very heavy pressure. Honing destroys the bearingized surface leaving a softer and rougher surface which will cause more rapid wear of piston and rubber cups. Higher friction produced by the rougher surface will also reduce braking power for a given pressure on brake pedal.

The maximum allowable clearance between piston and cylinder bore is .0055". If this clearance is increased by honing, the heavy pressure of brake fluid may force the rubber of the cup into the clearance and cause sticking or early failure of the cup. If a choice must be made between honing or replacement of the cylinder, it must be remembered that while a new cylinder may be more expensive, a honed cylinder may not give a satisfactory length of service.

d. Assembly of Brake Master Cylinder

1. Place master cylinder in a vise, so that outlet holes are up. Place check valve springs in outlet holes, so that they seat in depression in bottom of holes. Place new rubber check valves over springs, being careful not to displace springs from their seat.

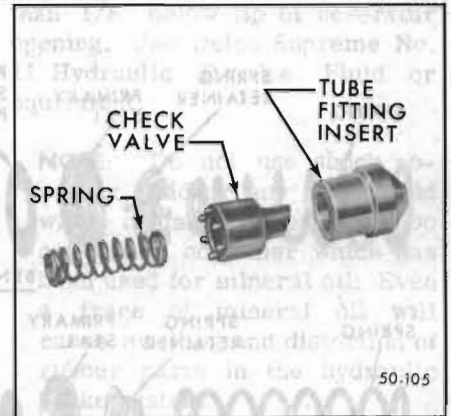

Figure 50-23—Tube Seat, Check Valve and Spring

2. Place brass tube fitting insert (new parts) in outlet holes, so that it is in a position to be pressed into outlet hole. Be sure that it is not cocked, as this would cause burrs to be turned up when tube fitting insert is pressed in. The recommended method of inserting tube fitting insert is to thread a spare brake line tube nut into outlet hole and turn nut down until tube fitting insert bottoms. Remove tube nut and check outlet hole for loose burrs, which might have been turned up when tube fitting insert was pressed down.

3. Put new secondary seals in two grooves in end of secondary piston. The seal which is nearest the end will have its lip facing toward that end. The seal in the second groove should have its lip facing toward the portion of the secondary piston, which contains the compensating holes.

4. Assemble a new primary seal protector and primary seal over end of secondary piston, so that flat side of the seal seats against the seal protector and the protector against flange of piston which contains the compensating holes.

5. Assemble new secondary seal into groove on push rod end of the primary piston. The lip of seal

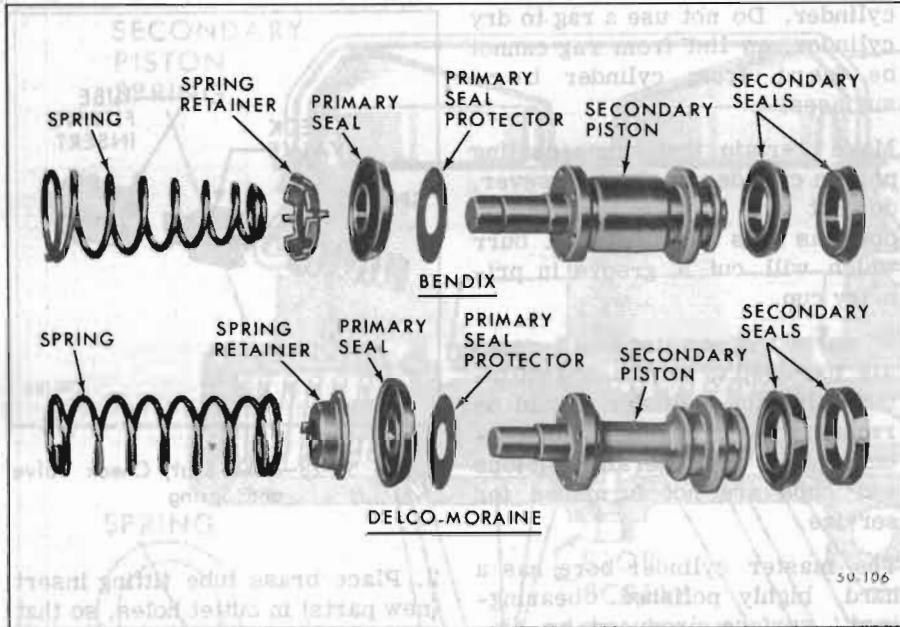

Figure 50-24—Secondary Piston - Exploded View

should face toward the compensating holes in opposite end of primary piston.

6. Assemble a new primary seal protector and primary seal on end of primary piston, so that flat side of seal seats against the seal protector and the protector against flange on piston which contains the compensating holes.

7. Assemble spring retainer in one end of primary piston spring and secondary piston stop in other end. Place end of spring over end of primary piston, so that spring retainer seats inside lip of primary seal.

8. Remove all cleaning liquid from threaded hole in primary piston. Place piston extension screw down through secondary piston stop and primary spring retainer. Tighten screw into primary piston until it bottoms. Torque to 80-100 lb. in.

9. Coat bore of master cylinder with clean brake fluid. Coat primary and secondary seals on secondary piston with clean brake fluid. Insert the secondary piston spring retainer into secondary

piston spring. Place retainer and spring over end of secondary piston, so that retainer locates inside lip of the primary cup.

10. Hold master cylinder with open end of bore down, push secondary piston into bore, so that spring will seat against closed end of bore.

11. Place master cylinder in a

vice with open end of bore up. Coat primary and secondary seal on primary piston with clean brake fluid. Push primary piston assembly, spring end first, into bore of master cylinder. Hold the piston down and snap lock ring into position in groove in inside diameter of bore.

12. Continue to hold primary piston down. This will also move the secondary piston forward. The secondary piston will now be forward far enough to clear stop screw hole, which is in bottom of front fluid reservoir (Delco Moraine) or exterior bottom of master cylinder (Bendix).

Install seal on stop screw (Bendix) and position stop screw in hole and torque to 33 lb. in.

13. Install a new reservoir diaphragm in reservoir cover, where needed, and install cover on master cylinder. Beaded side faces master cylinder casting to insure positive sealing. The bail wire is now pushed into position to hold reservoir cover.

14. (Manual brake only.) Assemble push rod through push rod retainer, if it has been disassembled. Push retainer over end of

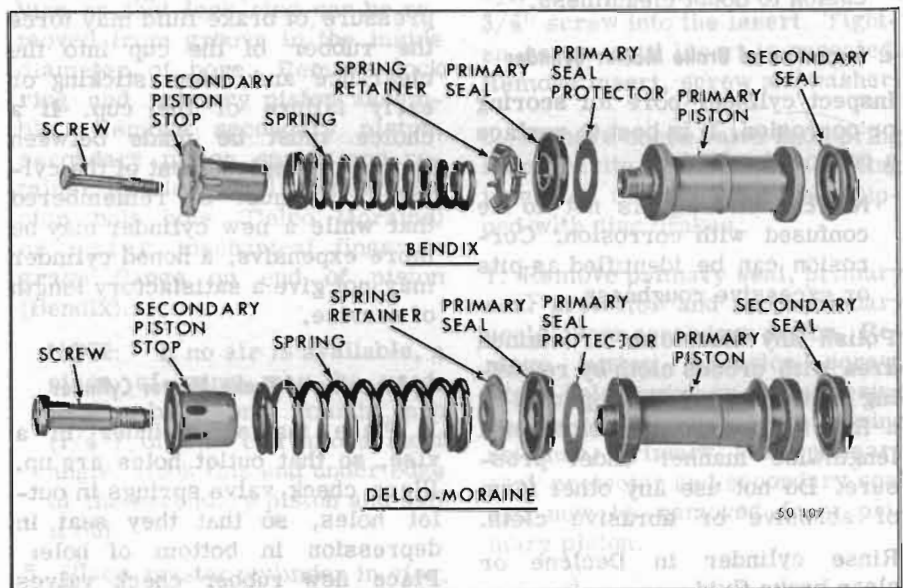

Figure 50-25—Primary Piston - Exploded View

master cylinder. Assemble new boot over push rod and press it down over the push rod retainer. Thread jam nut down to shoulder on push rod. Thread clevis down to jam nut. Torque nut against clevis to 14 lb. ft.

e. Installation of Brake Master Cylinder

1. Install master cylinder on dash or power cylinder. Torque nuts to 24 lb. ft.

2. (Manual brake only.) Connect push rod to brake pedal by installing clevis pin and retainer clip on 43-44000 series or washer and retaining pin on 45-46000 series.

3. Connect brake pipes to master cylinder. Outlet boss thread sizes for front and rear are different, as are brake line fittings. This will insure that correct connections are made, provided original brake lines have not been changed.

4. Bleed hydraulic system as described in paragraph 56-2. The master cylinder is now bled as though it were two separate master cylinders. (43-44000 series, power brakes only, bleed master cylinder first, then bleed wheel cylinders). Bleed wheel cylinders nearest to master cylinder first and check for proper pedal feel. If system has air in it, bleed other wheel cylinders. After bleeding, bring fluid to no more than 1/8" below lip of reservoir opening.

5. Road test car for proper brake performance. (Division IV).

56-1 REPLACING BRAKE PIPES

Since brake pipe assemblies (except master cylinder to distributor or metering valve) are not available from Buick Parts Warehouses, it is therefore necessary to order service bulk tubing and fittings to make-up any pipe assembly which is needed. All brake pipes must be made of tin plated or copper coated wrapped steel

tubing with the ends double lap flared.

CAUTION: Never use copper tubing because copper is subject to fatigue cracking which would result in brake failure.

To make-up a brake pipe assembly, proceed as follows:

1. Procure the recommended tubing and steel fitting nuts of the correct size. (Outside diameter of tubing is used to specify size.)

2. Cut tubing to length. Correct length may be determined by measuring old pipe using a cord and adding 1/8" for each double lap flare.

3. Double lap flare tubing ends using a suitable flaring tool. Follow instructions included in tool set.

NOTE: Make sure fittings are installed before starting second flare.

CAUTION: Double lap flaring tool must be used as single lap flaring tools cannot produce a flare strong enough to hold the necessary pressure.

4. Bend pipe assembly to match old pipe using a tubing bender.

56-2 FILLING, BLEEDING AND FLUSHING BRAKE HYDRAULIC SYSTEM

a. Filling Brake Master Cylinder

The master cylinder must be kept properly filled to insure adequate reserve and to prevent air from entering the hydraulic system. However, because of expansion due to heat absorbed from brakes and from engine, master cylinder must not be overfilled.

The brake fluid reservoir is on the master cylinder which is located under the hood on the left side of the dash.

Thoroughly clean reservoir cover before removal to avoid getting dirt into reservoir. Remove cover and diaphragm. Add fluid as required to bring level to no more

than 1/8" below lip of reservoir opening. Use Delco Supreme No. 11 Hydraulic Brake Fluid or equivalent.

NOTE: Do not use shock absorber fluid or any other fluid which contains mineral oil. Do not use a container which has been used for mineral oil. Even a trace of mineral oil will cause swelling and distortion of rubber parts in the hydraulic brake system.

b. Bleeding Brake Hydraulic System

A bleeding operation is necessary to remove air whenever it is introduced into the hydraulic brake system. Since air is compressible and hydraulic fluid is not, the presence of air in the system is indicated by a springy, spongy feeling of the brake pedal accompanied by poor braking action.

Air can be introduced into the hydraulic system if the brake pedal is operated when the fluid is too low in master cylinder reservoir. Air will also enter the system whenever any part of hydraulic system is disconnected.

It may be necessary to bleed the hydraulic system at all four wheel cylinders if air has been introduced through low fluid level or by disconnecting brake pipe at master cylinder. If brake pipe is disconnected at any wheel cylinder, then that wheel cylinder only need be bled. If pipes are disconnected at any fitting located between master cylinder and wheel cylinders, then all wheel cylinders served by the disconnected pipe must be bled.

NOTE: On 43-44000 power brake equipped models, the master cylinder and power brake unit is mounted at an angle on the dash. Two bleeder valves are located on the master cylinder. Because of the mounting angle, it will be necessary to bleed the master cylinder first and then the

wheel cylinders whenever the master cylinder reservoir has become empty or whenever the master cylinder is removed from car.

c. Sequence for Bleeding Wheel Cylinders

It is advisable to bleed one wheel cylinder at a time to avoid allowing fluid level in reservoir to become dangerously low. The correct sequence of bleeding is to bleed wheel cylinder, either front or rear system, nearest master cylinder first. This sequence expels air from lines and wheel cylinders nearest to master cylinder first and eliminates possibility that air in a line close to master cylinder may enter a line farther away after it has been bled.

NOTE: Do not perform bleeding operation while any brake drum is removed.

d. Bleeding Wheel Cylinder without Pressure Tank

1. Fill master cylinder (subpar. a, above).
2. Install Bleeder Wrench J-21472 on bleeder valve. Slip a brake bleeder tube over ball of wheel cylinder bleeder valve. Place lower end of bleeder tube in a

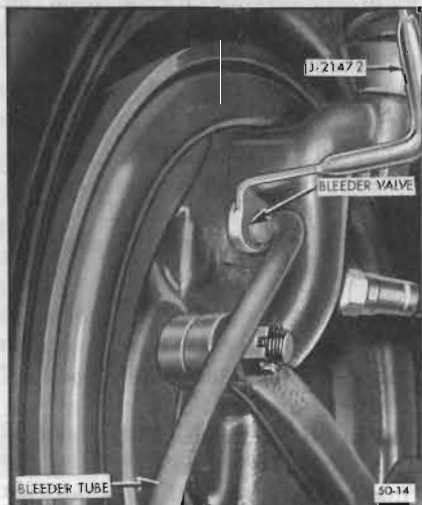

Figure 50-26—Bleeding Front Wheel Cylinder

glass jar that is partially filled with clean brake fluid. Position end of tube so that it will remain submerged under fluid during bleeding operation. Unscrew bleeder valve 3/4 of a turn. See Figure 50-26.

3. Depress brake pedal a full stroke, then allow pedal to return slowly to released position. Allowing pedal to return quickly may draw air into system. Continue operating pedal in this manner until fluid flows from bleeder tube into glass jar in a solid stream that is free of air bubbles, then close the bleeder valve securely and remove bleeder tube and wrench.

4. Frequently check master cylinder to make sure that it contains fluid. Allowing reservoir to be emptied will cause air to be drawn into hydraulic system.

5. When bleeding operation is completed at all wheel cylinders where needed, make sure that fluid level is no more than 1/8" below lip of reservoir, then install rubber diaphragm and cover.

6. Discard the brake fluid deposited in glass jar during bleeding operation. It is poor economy to attempt to clean fluid that has once been used.

e. Bleeding Wheel Cylinder with Pressure Tank

IMPORTANT: When using a pressure tank, air bubbles may form in the tank and enter the brake hydraulic system. To avoid this, observe the following points when handling a pressure tank: (1) Do not shake or agitate the pressure tank after air pressure has been added or is being added. (2) Allow pressure tank to stand in one position as much as possible and bring air hose over to tank when adding head of air. (3) Make certain the valves on the pressure tank lines are not defective allowing air to be sucked in when fluid

passes through the lines. (4) Pressure tank should be kept at least 1/3 full of fluid to avoid air bubbles forming, (5) if pressure tank is full of air bubbles, release air pressure and those bubbles will increase in size, be forced to top of fluid and escape.

1. Thoroughly clean master cylinder reservoir cover and surrounding area; then remove cover and diaphragm.

2. Make sure that pressure tank is at least 1/3 full of specified brake fluid and that hose and master cylinder reservoir are filled with fluid. Attach hose to master cylinder reservoir adapter cover.

3. Install Bleeder Wrench J-21472 on bleeder valve. Slip a brake bleeder tube over ball of wheel cylinder bleeder valve. Place lower end of bleeder tube in a clean glass jar. Unscrew bleeder valve 3/4 of a turn.

4. Open pressure tank hose valve to apply fluid to master cylinder under pressure that does not exceed 35 pounds. It is not necessary to pump the brake pedal when using pressure tank.

5. When fluid flows from bleeder tube into glass jar in a solid stream that is free of air bubbles, that particular cylinder and line are bled; tighten bleeder valve securely and remove bleeder tube.

6. When bleeding operation is completed at all wheel cylinders, where needed, make sure that fluid level is no more than 1/8" below lip of reservoir. Install rubber diaphragm and cover.

f. Flushing Brake Hydraulic System

It is recommended that the entire hydraulic system be thoroughly flushed whenever new parts are installed in the hydraulic system. Flushing is also recommended if

there is any doubt as to the grade of fluid in the system or if fluid has been used which contains the slightest trace of mineral oil.

Flushing is performed at each wheel cylinder in turn, and in the same manner as the bleeding operation except that bleeder valve is opened 1-1/2 turns and the fluid is forced through the pipes and wheel cylinder until it emerges clear in color. Approximately one quart of fluid is required to flush the hydraulic system thoroughly.

When flushing is completed at all wheel cylinders, make certain that master cylinder reservoir is filled to proper level.

DIVISION IV TROUBLE DIAGNOSIS

59-1 INSPECTING AND TESTING BRAKES

a. Inspecting Brakes

At reasonably frequent intervals, the brakes should be inspected for pedal reserve, which is the clearance between the pedal pad and the toeboard. Inspection should be made with brake pedal firmly depressed while brakes are cold.

Pedal reserve on manual brake-equipped car should be not less than 2-1/4". On power brake-equipped car, pedal reserve should be not less than 1-1/2".

Heat generated by high speed stops will expand brake drums and increase shoe clearance, thereby permitting pedal pad to

go closer to toeboard when brakes are hot.

Brake shoe linings should not be permitted to wear down until rivet contact drums because drums will be scored. As car mileage approaches the point where relining may be required, it is advisable to remove one or more drums for inspection of lining in order to avoid possibility of damaging brake drums.

b. Testing Brakes

Overall brake performance cannot be properly tested with the wheels jacked up because this procedure does not test the self-energizing servo action of the brake shoes and the effect of car weight distribution on deceleration.

Brakes should be tested on dry, clean, reasonably smooth and level roadway. A true test of brake performance cannot be made if roadway is wet, greasy or covered with loose dirt so that all tires do not grip the road equally. Testing will also be adversely affected if roadway is crowned so as to throw weight of car toward wheels on one side or if roadway is so rough that wheels tend to bounce.

Test brakes at different car speeds with both light and heavy pedal pressure; however, avoid locking the wheels and sliding the tires on roadway. Locked wheels and sliding tires do not indicate brake efficiency since heavily braked, but turning wheels will stop car in less distance than locked wheels. More tire-to-road friction is present with a

heavily braked turning tire than with a sliding tire.

c. External Conditions that Affect Brake Performance

In addition to roadway conditions mentioned above (subpar. b), the following external conditions may affect brake performance and should be corrected before work is done on the brake mechanism.

1. Tires. Tires having unequal contact and grip on road will cause unequal braking. Tires must be equally inflated and non-skid tread pattern of right and left tires must be approximately equal.

2. Car Loading. When car has unequal loading, the most heavily loaded wheels require more braking power than others. A heavily loaded car requires more braking effort.

3. Front Wheel Bearings. A loose front wheel bearing permits the drum to tilt and have spotty contact with brake shoe linings causing erratic brake action. See Group 100.

4. Front End Alignment. Misalignment of the front end particularly in regard to limits on camber and theoretical king pin inclination will cause brake action to appear unequal between sides.

5. Shock Absorbers. Faulty shock absorbers that permit bouncing of car on quick stops may give the erroneous impression that brakes are too severe.

59-2 BRAKE TROUBLE INDICATIONS AND CORRECTIONS

CONDITION	POSSIBLE CAUSE	CORRECTION
EXCESSIVE PEDAL TRAVEL (Low pedal)	<ol style="list-style-type: none"> 1. Master cylinder fluid level low. 2. Poor quality brake fluid (low boiling point) in system. 3. Air in hydraulic system. 4. Hoses soft and weak (expanding under pressure). 5. Excessive Brake Shoe Clearance. 6. Wheel bearings or steering parts loose or worn (causing shoe and lining knockback). 7. Partial system failure. 	<ol style="list-style-type: none"> 1. Fill to proper level with approved fluid. 2. Flush hydraulic system and fill with approved fluid. 3. Bleed hydraulic system and refill with approved fluid. 4. Replace defective hoses. 5. Check self-adjusting mechanism. 6. Adjust or replace defective parts. 7. Correct as necessary.
SPONGY PEDAL (Springy sensation to pedal upon brake application)	<ol style="list-style-type: none"> 1. Master cylinder fluid level low. 2. Poor quality brake fluid (low boiling point) in system. 3. Air in hydraulic system. 4. Hoses soft or weak (expanding under pressure). 5. Brake drum out-of-round. 	<ol style="list-style-type: none"> 1. Fill to proper level with approved fluid. 2. Flush hydraulic system and fill with approved fluid. 3. Bleed hydraulic system and refill with approved fluid. 4. Replace defective hoses. 5. Resurface brake drum.
HARD PEDAL (Excessive pedal pressure needed to stop vehicle)	<ol style="list-style-type: none"> 1. Power brake malfunctioning. 2. Linings soiled with brake fluid, oil or grease. 3. Lines, hoses or connections dented, kinked, collapsed or clogged. 4. Master cylinder piston compensating port closed. 5. Master cylinder cups swollen. 	<ol style="list-style-type: none"> 1. Check and repair power unit. 2. Replace shoes and linings. 3. Repair or replace defective parts. 4. Overhaul master cylinder. 5. Flush hydraulic system and replace all cups and seals in complete brake system.

CONDITION	POSSIBLE CAUSE	CORRECTION
HARD PEDAL (Excessive pedal pressure needed to stop vehicle) (Cont'd.)	<ol style="list-style-type: none"> 6. Master cylinder bore corroded or rough. 7. Pedal push rod and linkage binding. 	<ol style="list-style-type: none"> 6. Repair or replace master cylinder. 7. Free up and lubricate.
DRAGGING, GRABBING OR PULLING (Severe reaction to pedal pressure and out of line stops)	<ol style="list-style-type: none"> 1. Linings soiled with brake fluid, oil or grease. 2. Brake drum out-of-round. 3. Lines, hoses or connections dented, kinked, collapsed or clogged. 4. Master cylinder bore corroded or rough. 5. Wheel cylinder bores corroded or rough. 6. Pedal linkage binding (and suddenly releasing). 7. Loose front wheel bearings. 8. Loose brake backing plate. 9. Excessive brake shoe clearance. 10. Weak or broken brake shoe spring. 11. Brake linings not matched, or improperly placed. 12. Tires unequal. 13. Camber unequal. 	<ol style="list-style-type: none"> 1. Replace shoes and linings. 2. Resurface brake drum. 3. Repair or replace defective parts. 4. Repair or replace master cylinder. 5. Disassemble and remove corrosion or roughness, or replace wheel cylinder. 6. Free up and lubricate linkage. 7. Adjust bearings as necessary. 8. Tighten backing plate bolts. 9. Check self-adjusting mechanism. 10. Replace defective spring. 11. Replace or change linings as required. 12. Rearrange or inflate tires as required. 13. Adjust camber to specifications (Group 100).
FADING PEDAL (Pedal falling away under steady pressure)	<ol style="list-style-type: none"> 1. Poor quality brake fluid (low boiling point) in system. 2. Hydraulic connections loose; lines or hoses ruptured (causing leakage). 3. Master cylinder primary cup worn or damaged. 4. Master cylinder bore corroded, worn or scored. 	<ol style="list-style-type: none"> 1. Flush hydraulic system and fill with approved fluid. 2. Tighten or replace defective parts. 3. Repair master cylinder. 4. Repair or replace master cylinder.

CONDITION	POSSIBLE CAUSE	CORRECTION
<p>FADING PEDAL (Pedal falling away under steady pressure) (Cont'd.)</p>	<ul style="list-style-type: none"> 5. Wheel cylinder seals worn or damaged. 6. Wheel cylinder bores corroded, worn or scored. 7. Bleed screw open. 	<ul style="list-style-type: none"> 5. Replace seals. 6. Disassemble wheel cylinder and remove corrosion or scoring, or replace cylinder. 7. Close bleed screw and bleed hydraulic system.
<p>NOISE AND CHATTER (May be accompanied by brake roughness and pedal pumping)</p>	<ul style="list-style-type: none"> 1. Car creeping or moving slowly with brakes applied (may produce groan or crunching noise). 2. Bent brake backing plate. 3. shoes slapping against backing plate. 4. Lining loose on brake shoes. 5. Shoes scraping on backing plate. 6. Improper brake shoe lining. 7. Foreign material imbedded in lining. 8. Brake drum condition. 	<ul style="list-style-type: none"> 1. Increase or decrease pedal effort slightly. 2. Repair or replace backing plate. 3. Resurface brake drum. 4. Reset or replace rivets. 5. Lubricate shoe contact surfaces on backing plate. 6. Install correct lining. 7. Clean or replace lining. 8. Resurface scored or out-of-round drums. Replace cracked drums.