

SECTION G

46-48-49000 STANDARD DIFFERENTIAL

CONTENTS

Division	Paragraph	Subject	Page
I	40-34	SPECIFICATIONS AND ADJUSTMENTS: Differential Specifications	40-78
II	40-35	DESCRIPTION AND OPERATION: Description and Operation of Standard Differential	40-79
III	40-36 40-37 40-38 40-39	SERVICE PROCEDURES: Removal and Installation of Differential Assembly Removal and Installation of Axle Shaft, Wheel Bearing or Oil Seal Removal and Disassembly of Differential Case Assembly Assembly and Installation of Differential Case Assembly	40-82 40-83 40-85 40-87
IV	40-40	TROUBLE DIAGNOSIS: Pre-Repair Investigation and Trouble Diagnosis	40-93

DIVISION I SPECIFICATIONS AND ADJUSTMENTS

40-34 DIFFERENTIAL SPECIFICATIONS

a. Tightening Specifications

Use a reliable torque wrench to tighten the parts listed, to insure proper tightening without straining or distorting parts. These specifications are for clean and lightly lubricated threads only; dry or dirty threads produce increased friction which prevents accurate measurement of tightness.

Part	Location	Thread Size	Torque Lbs. Ft.
Nut	Clamp, Rear U-Joint to Pinion Flange, 46-48000	5/16-18	12
Bolt	Rear CV Joint to Pinion Flange, 49000	7/16-14	85
Bolt	Differential Cover to Housing	5/16-18	30
*Nut	Upper and Lower Control Arm	1/2 -13	80
*Bolt	Upper and Lower Control Arm	1/2 -13	110
*Nut & Bolt	Upper Control Arm Vernier Adjustment (49000)	7/16-14	48
Nut	Rear Shock, Lower End	1/2 -20	45
Bolt	Ring Gear to Case	7/16-20	85
Nut	Wheel Bearing Retainer and Brake Assembly to Housing	3/8 -16	35
Bolt	Differential Bearing Cap to Housing	7/16-14	53
Nut	Wheel and Brake Drum to Rear Axle Shaft	1/2 -20	65
Nut & Bolt	Track Bar to Differential or Frame Bracket, 49000	5/8 -18	120

*Torquing of Nut or Bolt to be optional.

b. General Specifications

Item	All Series (Except as otherwise noted)
Differential Type	Semi-Floating Hypoid
Drive and Torque 46-48000	Through 4 Control Arms
Drive and Torque 49000	Through 3 Control Arms
Differential Oil Capacity	4-1/4 Pints
Ring and Pinion Gear Set Type	Hypoid
Rear Universal Joint Angle Adjustment, 46-48000	Shim at Upper Control Arm to Frame
Rear Universal Joint Angle Adjustment, 49000	Vernier-Upper Control Arm

c. Limits for Fitting and Adjusting

Pinion Bearing Preload (Measured at pinion flange nut)	
New Bearings	25-30 inch lb. rotating torque with new seal, less ring gear
Reused Bearings	10-15 inch lb. rotating torque with new seal, less ring gear
Total Assembly Preload (Measured at pinion flange nut)	
New Bearings	35-40 inch lb. rotating torque with new seal, with ring gear
Reused Bearings	25-30 inch lb. rotating torque with new seal, with ring gear
Ring Gear Position007", .008", .009" Backlash

d. Differential Gear Ratio

The gear ratio is indicated by letters stamped on the bottom of the right axle tube. The production date is also indicated by a stamped number which represents the day of the year starting with "1" for January 1. See Figure 40-140.

e. Speedometer Gear

Speedometer gear must correspond to axle ratio and tire size in order to have correct speedometer and odometer reading.

DIVISION II

DESCRIPTION AND OPERATION

40-35 DESCRIPTION AND OPERATION OF STANDARD DIFFERENTIAL

The differential assembly is of the semi-floating type in which the car weight is carried on the axle shafts through ball bearings enclosed in the outer axle housing. The differential assembly is designed for use with an open drive line and coil springs.

On the 46 and 48000 Series, drive from the differential housing is transmitted to the frame through

AXLE RATIO	SERIES					
	46000		48000		49000	
	STD. AXLE	P.T. AXLE	STD. AXLE	P.T. AXLE	STD. AXLE	P.T. AXLE
2.56	—	—	PB	PN	—	—
2.78	PL	PO	PL	PO	—	—
3.07	PG	PV	—	—	PJ	PM
3.42	—	PW	—	PW	—	PY
3.91	—	PX	—	PX	—	PS

FOR FIELD IDENTIFICATION, ALL AXLE ASSEMBLIES — TO BE STAMPED WITH LETTERS 1/4" HIGH ON BOTTOM OF AXLE TUBE AS INDICATED FROM CHART. SAMPLE MARKING FOR 3.07 RATIO, (FOR 46 MODEL), DATE JULY 22, (DAY IN THE YEAR MFG'D.) WOULD BE. STANDARD AXLES PG 203; POSITIVE TRACTION AXLES ⊗PV 203.

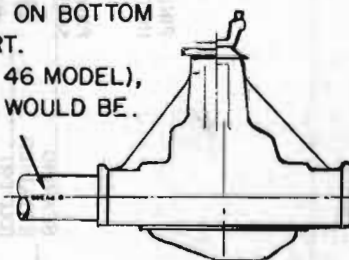

40-207

Figure 40-140—Differential Identification

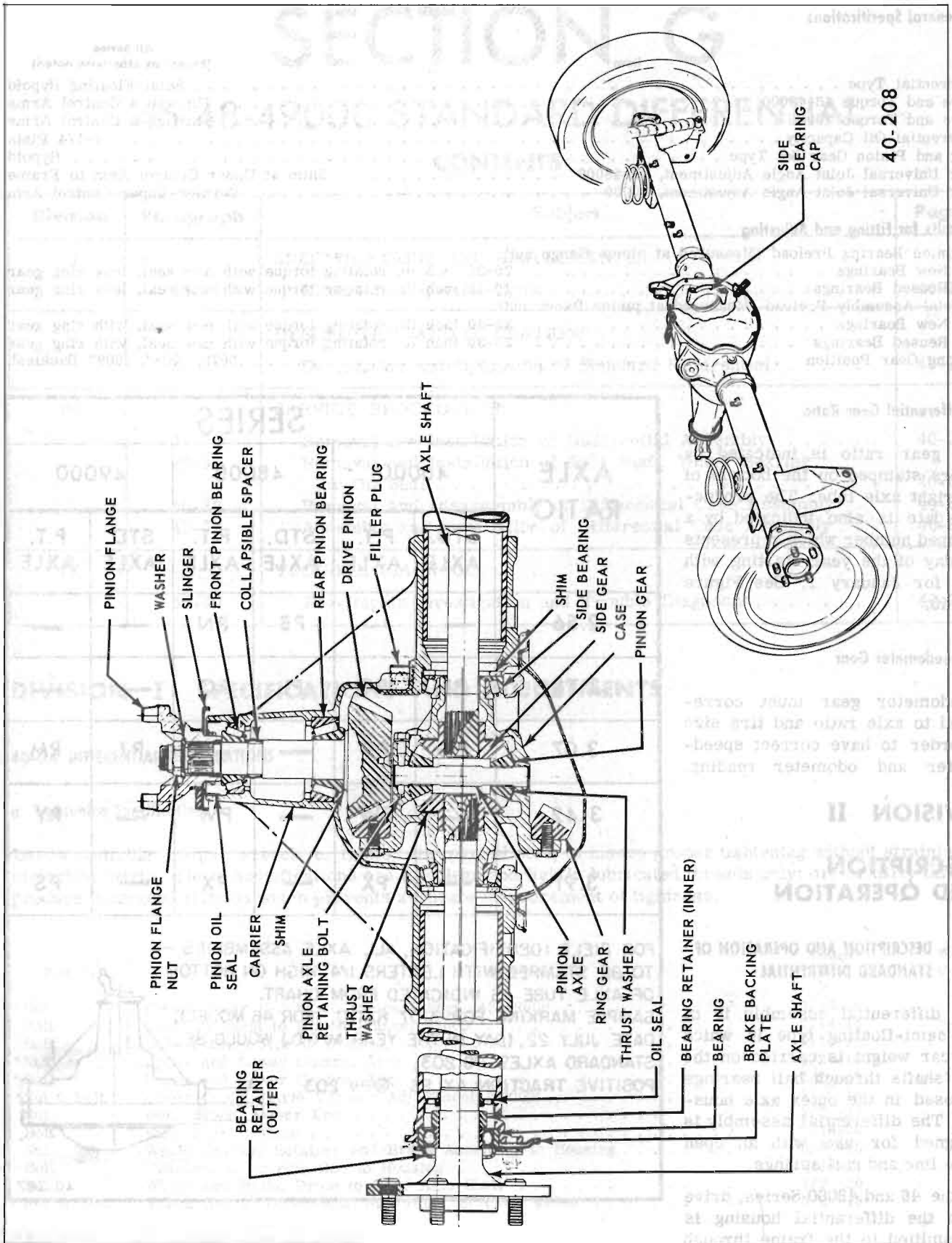

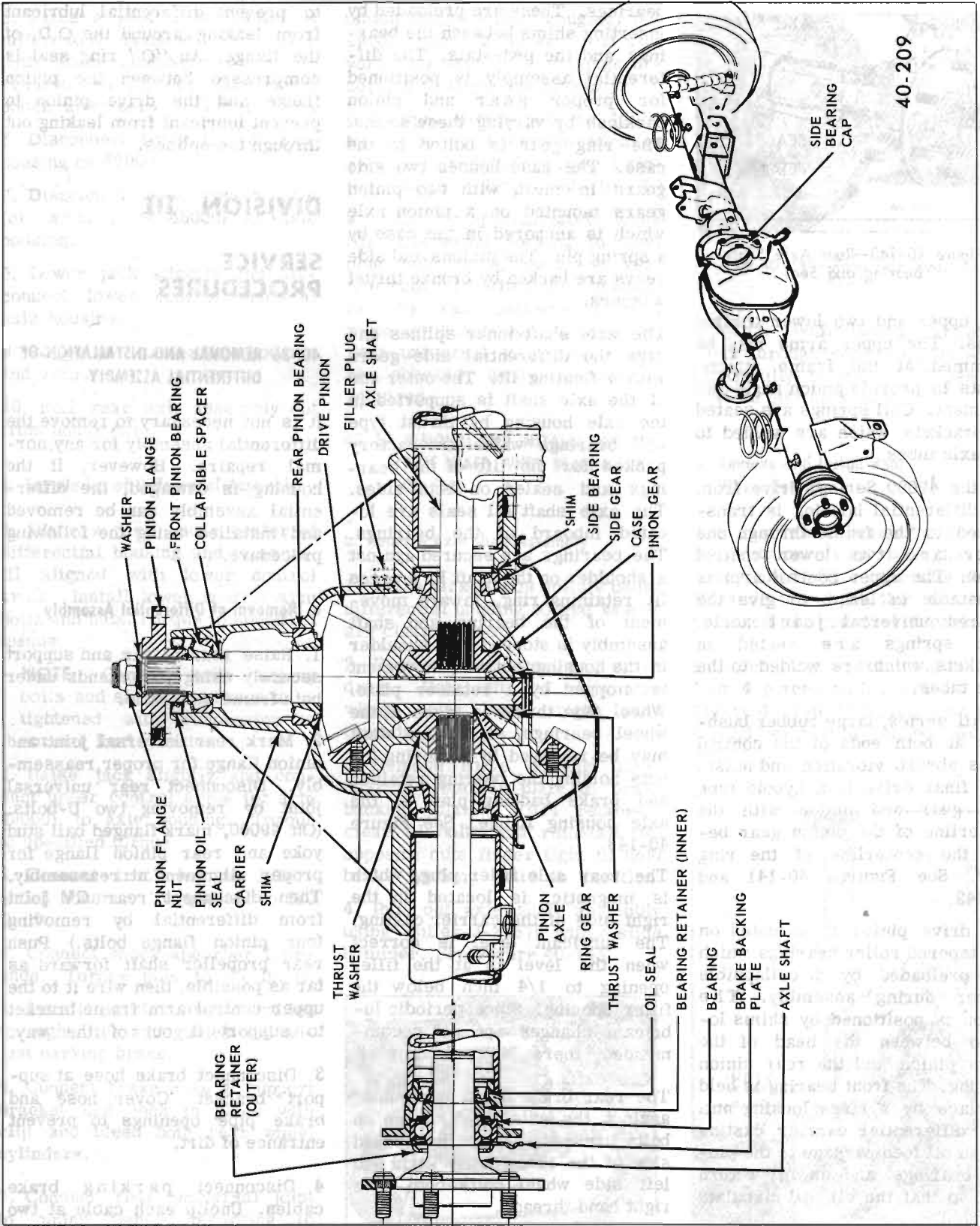

Figure 40-142 49000 Differential Assembly

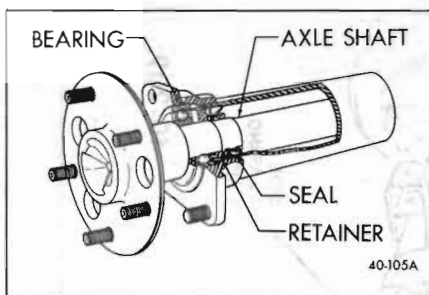

Figure 40-143—Rear Axle Shaft Bearing and Seal

two upper and two lower control arms. The upper arms may be shimmed at the frame attachments to provide pinion angle adjustment. Coil springs are seated in brackets which are welded to the axle tubes.

On the 49000 Series, drive from the differential housing is transmitted to the frame through one upper and two lower control arms. The upper control arm is adjustable in length to give the desired universal joint angle. Coil springs are seated in brackets which are welded to the axle tubes.

On all series, large rubber bushings at both ends of the control arms absorb vibration and noise. The final drive is a hypoid type ring gear and pinion with the centerline of the pinion gear below the centerline of the ring gear. See Figures 40-141 and 40-142.

The drive pinion is mounted on two tapered roller bearings which are preloaded by a collapsible spacer during assembly. The pinion is positioned by shims located between the head of the drive pinion and the rear pinion bearing. The front bearing is held in place by a large locking nut. The differential carrier casting has an oil feed passage to the pinion bearings and an oil return hole so that the oil will circulate and cool.

The differential is supported in carrier by two tapered roller side

bearings. These are preloaded by inserting shims between the bearings and the pedestals. The differential assembly is positioned for proper gear and pinion backlash by varying these shims. The ring gear is bolted to the case. The case houses two side gears in mesh with two pinion gears mounted on a pinion axle which is anchored in the case by a spring pin. The pinions and side gears are backed by bronze thrust washers.

The axle shaft inner splines engage the differential side gears with a floating fit. The outer end of the axle shaft is supported in the axle housing by thrust type ball bearings which are factory packed for the life of the bearings and sealed on both sides. The axle shaft oil seals are located inboard of the bearings. The bearings are secured against a shoulder on the shaft by a press fit retaining ring. Inward movement of the bearing and shaft assembly is stopped by a shoulder in the housing; outward movement is stopped by a retainer plate. Wheel side thrust is taken at the wheel bearings, so an axle shaft may be removed by removing the nuts holding the bearing retainer and brake backing plate to the axle housing flange. See Figure 40-143.

The rear axle filler plug, which is magnetic, is located in the right side of the carrier casting. The lubricant level is correct when the level is at the filler opening to 1/4 inch below the filler opening. Since periodic lubricant changes are not recommended, there is no drain plug.

The rear brake drum is mounted against the axle shaft flange on bolts pressed through the inboard side of the axle flange. Right and left side wheel bolts both have right hand threads.

A seal in the front of the carrier bears against the pinion flange

to prevent differential lubricant from leaking around the O.D. of the flange. An "O" ring seal is compressed between the pinion flange and the drive pinion to prevent lubricant from leaking out through the splines.

DIVISION III

SERVICE PROCEDURES

40-36 REMOVAL AND INSTALLATION OF DIFFERENTIAL ASSEMBLY

It is not necessary to remove the differential assembly for any normal repairs. However, if the housing is damaged, the differential assembly can be removed and installed using the following procedure.

a. Removal of Differential Assembly

1. Raise rear of car and support securely using jack stands under both frame side rails.
2. Mark rear universal joint and pinion flange for proper reassembly. Disconnect rear universal joint by removing two U-bolts. (On 49000, mark flanged ball stud yoke and rear pinion flange for proper alignment at reassembly. Then disconnect rear CV joint from differential by removing four pinion flange bolts.) Push rear propeller shaft forward as far as possible, then wire it to the upper control arm frame bracket to support it out of the way.
3. Disconnect brake hose at support bracket. Cover hose and brake pipe openings to prevent entrance of dirt.
4. Disconnect parking brake cables. Unclip each cable at two places, disengage from guides, pull each cable free and lay-out forward from rear wheels.

5. Place a jack under center of differential housing and raise until shock absorbers are compressed slightly. Disconnect shock absorbers at lower ends.

6. Disconnect track bar at axle housing on 49000.

7. Disconnect upper control arm (or arms, 46-48000) at axle housing.

8. Lower jack slightly and disconnect lower control arms at axle housing.

9. Lower jack under axle housing and remove.

10. Roll rear axle assembly out from under car.

b. Installation of Differential Assembly

1. Place a jack under center of differential housing and raise until aligned with lower control arms. Install lower control arm bolts and nuts. Torque to specified torque.

NOTE: Control arm bushing bolts and shock absorbers to be tightened with suspension in normal load position.

2. Raise jack slightly and connect upper control arms (or arm 49000) to axle housing. Torque to specified torque.

3. Connect track bar to differential housing. Torque nut to 120 lb. ft.

4. Connect shock absorber lower ends. Torque nuts to 45 lb. ft.

5. Install parking brake cables through clips and guides and adjust parking brake.

6. Connect brake hose at support bracket and lock in place with clip and bleed both rear wheel cylinders.

7. Connect rear universal joint to pinion flange according to alignment marks. Compress bearings using a C-clamp so that bearing snap rings will engage

pinion flange without gouging. (On 49000, connect flanged ball stud yoke and rear pinion flange according to alignment marks.)

8. Torque U-bolt nuts to 12 lb. ft. using an extension such as J-9113. (On 49000, torque 4 pinion flange bolts to 85 lb. ft.)

9. With car approximately level, fill differential housing to filler plug hole using specified gear lubricant. If differential housing or any rear suspension parts were replaced due to damage, rear universal joint angle must be checked and adjusted as required.

40-37 REMOVAL AND INSTALLATION OF AXLE SHAFT, WHEEL BEARING OR OIL SEAL

a. Remove Axle Shaft Assembly

1. Place jack stands solidly under differential housing so that wheels are clear of floor.

2. Remove rear wheel and brake drum. Both left and right side wheel bolts have right hand threads.

3. Remove nuts holding wheel bearing retainer plate to brake backing plate. Pull retainers clear of bolts and reinstall two opposite nuts finger tight to hold brake backing plate in position.

4. Pull out axle shaft assembly using Puller J-21579 with a slide hammer. See Figure 40-145.

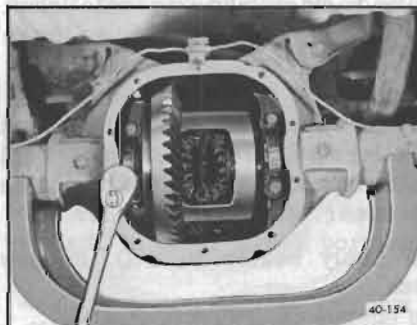

Figure 40-144—Differential in Position for Repair

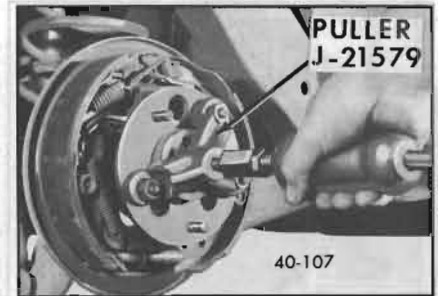

Figure 40-145--Removing Rear Axle Shaft

NOTE: While pulling axle shaft out through seal, support shaft carefully in center of seal to avoid cutting seal lip.

b. Remove and Install Rear Wheel Bearing

The rear wheel bearing and bearing retainer ring both have a heavy press fit on the axle shaft. Because of this fit, they should be removed or installed separately.

1. Notch bearing retaining ring in 3 or 4 places with a chisel. See Figure 40-146. Retaining ring will expand so that it can be slipped off.

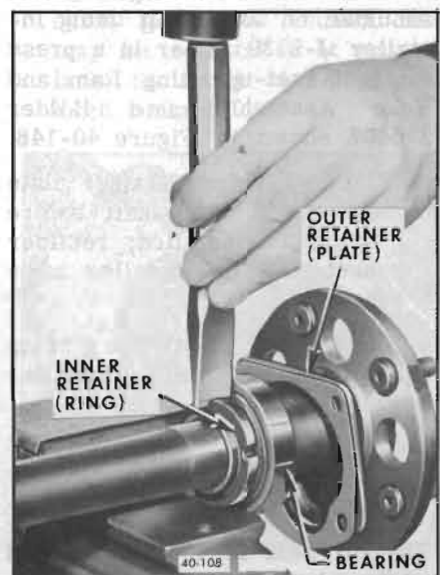

Figure 40-146—Removing Axle Shaft Bearing Retainer

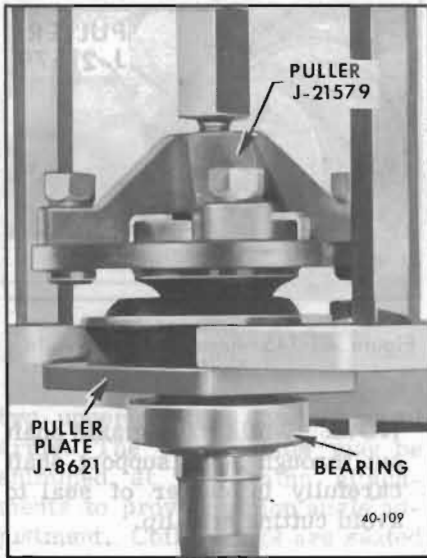

Figure 40-147—Removing Axle Shaft Bearing

NOTE: Axle shaft may be nicked if ring is cut completely through.

2. Press axle shaft bearing off, using Puller Plate J-8621 with Remover J-6525 either in a press or in a set-up using Ram and Yoke Assembly as shown in Figure 40-147.

3. Install bearing retainer plate. Press new bearing against shoulder on axle shaft using Installer J-9739 either in a press or in a set-up using Ram and Yoke Assembly and Holder J-6407 shown in Figure 40-148.

NOTE: Bearing retainer plate must be on axle shaft before bearing is installed; retainer gasket can be installed after bearing.

4. Press new retainer ring against bearing using Installer J-9739.

c. Remove and Install Axle Shaft Oil Seal

The oil seal is located inboard of the wheel bearing with its O.D. tight in the axle shaft tube and its sealing lip contacting a ground

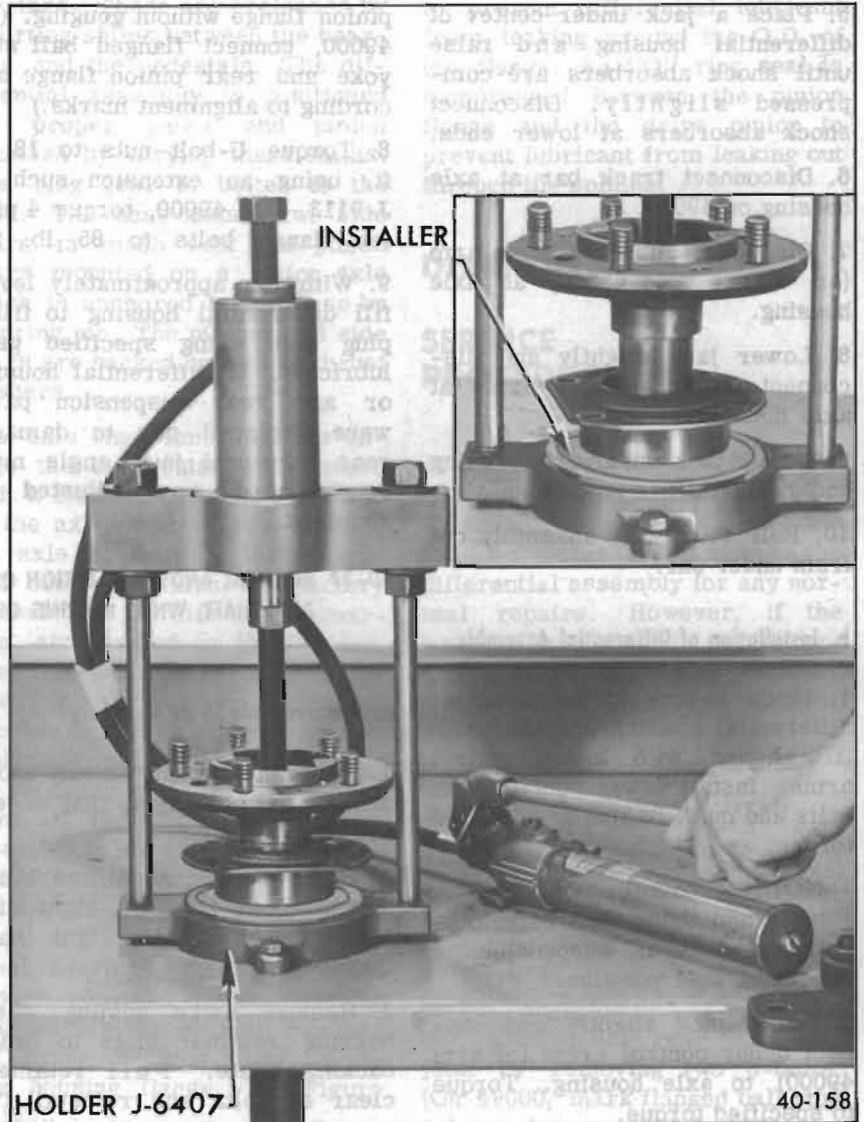

Figure 40-148—Installing Axle Shaft Bearing

surface of the axle shaft. See Figure 40-143. Before removing, install 2 nuts finger tight to retain backing plate to axle shaft tube. This protects the brake lines.

1. To remove oil seal, insert Puller J-6199 just through seal and expand. Pull seal with a slide hammer. See Figure 40-149.

2. Apply sealer to O.D. of new seal.

3. Position seal over Installer J-9740-01 and drive seal straight into tube until installer bottoms

against wheel bearing shoulder. See Figure 40-150.

4. Pack cavity and seal lip with front wheel bearing grease before installing axle shaft.

d. Remove and Install Rear Wheel Bolt

1. To remove and install a rear wheel bolt, axle shaft assembly must be out of car. Remove rear wheel bolt by pressing from axle flange.

2. Install new rear wheel bolt by pressing through axle shaft

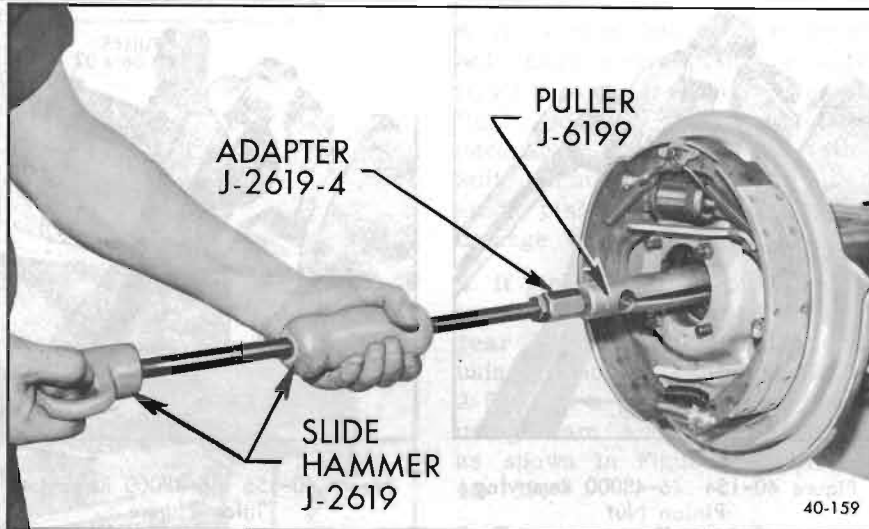

Figure 40-149—Removing Axle Shaft Seal

flange. Check new bolt for looseness; if bolt can be moved at all with fingers, axle shaft must be replaced.

e. Install Axle Shaft Assembly

Rear axle shafts are interchangeable between sides.

1. Apply a light coat of wheel bearing grease in wheel bearing recess of housing. Install new outer retainer plate gasket over retainer bolts.

2. Apply gear lubricant to the bearing surface and splines at the inner end of the axle shaft. Apply a coat of wheel bearing grease on the seal surface of the shaft to approximately 6 inches inboard of the shaft. Install axle shaft through seal carefully to avoid cutting seal lip. Drive shaft into position.

NOTE: If the axle to be installed is a positive traction axle, ONLY POSITIVE TRACTION LUBRICANT SHOULD BE USED.

3. Install retainer nuts and torque to 35 lb. ft.

4. Install drum and wheel. Torque lug nuts to 65 lb. ft.

40-38 REMOVAL AND DISASSEMBLY OF DIFFERENTIAL CASE ASSEMBLY

a. Removal of Differential Case Assembly—Differential in Car

1. Raise rear of car and support securely under rear of frame.

2. Loosen parking brake cables so that brake is not applied when differential assembly is lowered.

3. Mark rear universal joint and pinion flange for proper alignment at reassembly. Disconnect rear universal joint by removing two U-bolts. (On 49000, mark flanged ball stud yoke and rear pinion flange for proper alignment at reassembly. Disconnect rear CV joint by removing four pinion flange bolts.) Push rear propeller shaft forward as far as possible and wire it to the upper control arm frame bracket to support it out of the way.

4. Disconnect lower ends of both rear shock absorbers and lower differential assembly just far enough to clear lower portion of fuel tank.

NOTE: The following steps also apply when making repairs with differential assembly removed from car.

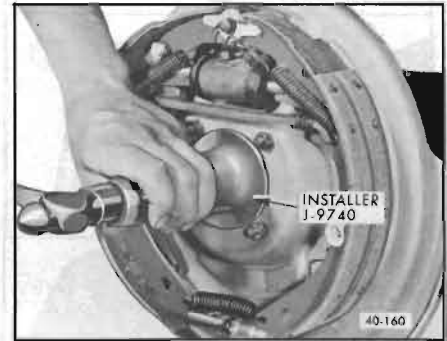

Figure 40-150—Installing Axle Shaft Seal

5. Remove bolts securing cover to housing to drain lubricant.

6. While lubricant is draining, remove rear wheels and drums.

7. Remove axle shafts as described in paragraph 40-37.

NOTE: Before proceeding with following steps, it is advisable to check the existing ring gear to pinion backlash as described in paragraph 40-39, subparagraph f. This will indicate gear or bearing wear or an error in backlash or preload setting which will help in determining cause of axle noise. Backlash should be recorded so that if same gears are reused, they may be reinstalled at original lash to avoid changing gear tooth contact.

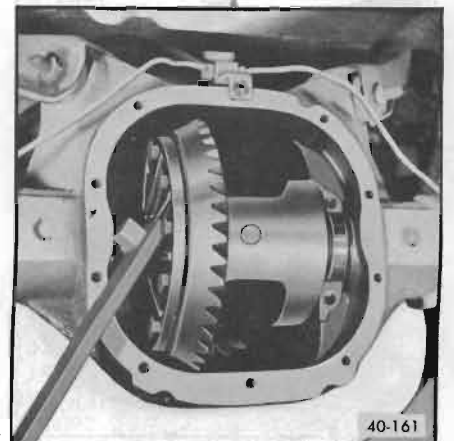

Figure 40-151—Removing Differential Case Assembly



Figure 40-152—Removing Differential Side Bearing

8. Mark side bearing caps and housing for proper installation of bearing caps at reassembly. Remove four bolts holding differential side bearing caps to housing.

9. Differential case assembly can now be removed by prying against ring gear bolt using a suitable pry bar. See Figure 40-151.

CAUTION: Do not allow case assembly to drop as this may cause injury or damage parts.

b. Disassembly of Differential Case Assembly

1. If differential side bearings are to be replaced, insert Re-



Figure 40-153—Removing Differential Pinion Axle Pin

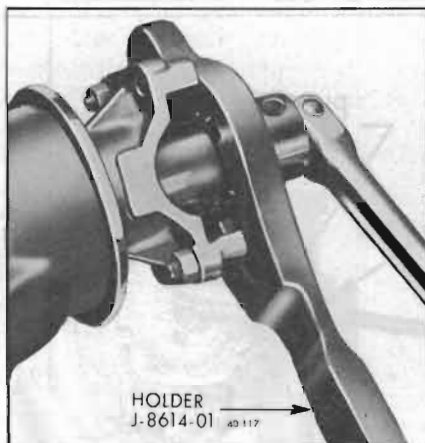

Figure 40-154 46-48000 Removing Pinion Nut

move Adapter J-2241-8 in center hole and pull bearing using Puller J-22588 or Hydraulic Puller J-9005. See Figure 40-152.

2. Remove pin that retains differential pinion axle using a suitable punch. See Figure 40-153. Remove differential pinion gears, side gears and thrust washers from case.

3. If ring gear or case is to be replaced and gear is tight on case after removing bolts, tap gear off using a soft hammer; do not pry between ring gear and case.

c. Removal of Pinion and Bearings

1. Check pinion preload as described in paragraph 40-39, subparagraph a. If there is no preload reading, check for looseness of pinion assembly by shaking. Any noticeable looseness

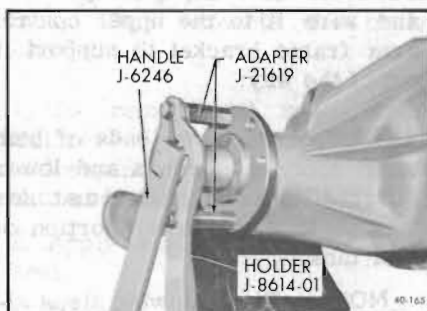

Figure 40-155 49000 Removing Pinion Nut

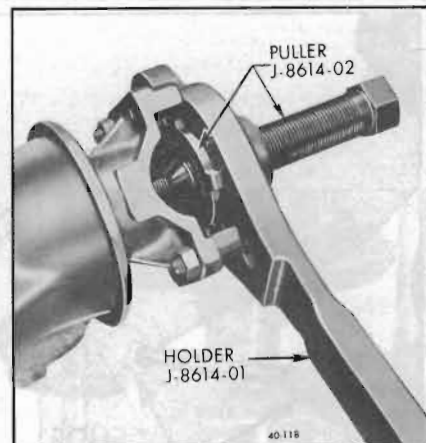

Figure 40-156 46-48000 Removing Pinion Flange

indicates worn or defective bearings, requiring replacement. If assembly is run long with very loose bearings, ring gear and pinion will be damaged and also need replacing.

2. Install Holder J-8614-01 on pinion flange using two 5/16-18 x 2" bolts with flat washers. (On 49000, install Holder J-8614-01 on pinion flange using Adapters J-21619). Remove pinion nut and washer. See Figures 40-154 or 40-155.

NOTE: Because of differences in castings, it may be necessary to file out slightly the slotted bolt holes in Holder in order to accommodate J-21619 Adapters.

3. Pull flange from pinion using

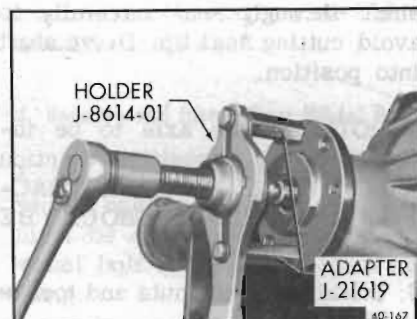

Figure 40-157 49000 Removing Pinion Flange



Figure 40-158—Installing Rear Pinion Bearing Remover

Puller J-8614-02 in Holder J-8614-01. (On 49000 use Puller J-8614-02 in Holder J-8614-01 with Adapters J-21619.) To install puller, back out puller screw, insert puller through holder, and rotate 1/8 turn. See Figures 40-156 or 40-157.



Figure 40-159—Removing Rear Pinion Bearing

4. As pinion flange is removed, hold hand under pinion to catch it, as it may fall through. Remove "O" ring seal from pinion. If necessary, tap pinion out with a soft hammer, being careful to guide pinion with hand to avoid damage to bearing outer races.

5. If pinion or rear pinion bearing is to be replaced, remove rear bearing from pinion shaft using Remover J-9746 and Holder J-6407 in a press or in a set-up using Ram and Yoke Assembly as shown in Figures 40-158 and 40-159.

6. Pry pinion oil seal from carrier, being careful not to damage front pinion bearing outer race. If front pinion bearing is to be replaced, drive outer race from carrier using a drift.

7. If rear pinion bearing is to be replaced, drive outer race from carrier using a drift.

40-39 ASSEMBLY AND INSTALLATION OF DIFFERENTIAL CASE ASSEMBLY

Before installation of any parts, examine the wearing surfaces of all parts for scoring or unusual wear. Make certain that the interior of the carrier housing is absolutely clean and dry. Also make certain that the parts to be assembled are absolutely clean and that there are no burred edges. Lubricate all parts with the specified rear axle lubricant just before assembly.

NOTE: If the Buick is equipped with a Positive Traction Differential, only Positive Traction Lube should be used.

NOTE: If the ring gear and pinion are changed, only factory hypoid lubricant should be used for filling because of its special anti-scoring properties. For this reason the proper lubricant is included in the carton with the replacement gears as received from the Buick warehouses.

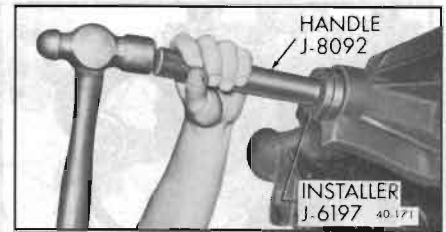

Figure 40-160—Installing Front Pinion Bearing Outer Race

a. Install Pinion Bearings and Pinion Gear and Adjust Pinion Preload

1. Drive front pinion bearing outer race against shoulder on carrier using Replacer J-6197 with driver handle. See Figure 40-160.

2. Drive rear pinion bearing outer race against shoulder in carrier using Replacer J-9745 with driver handle. See Figure 40-161.

3. Place correct shim (as determined in subpar. b) against head of pinion and install rear pinion bearing using Replacer J-6377 and Holder J-6407 with Ring J-6407-2 in a press or as shown in Figure 40-162.

4. Position pinion assembly in carrier and install collapsible spacer as shown in Figure 40-163.

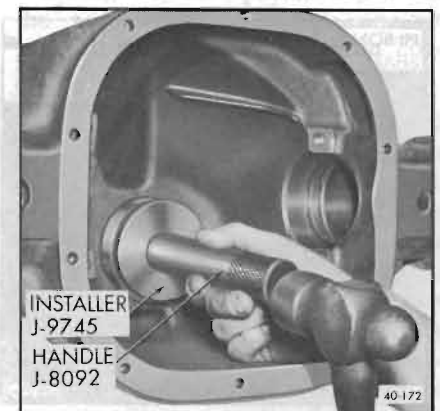

Figure 40-161—Installing Rear Pinion Bearing Outer Race

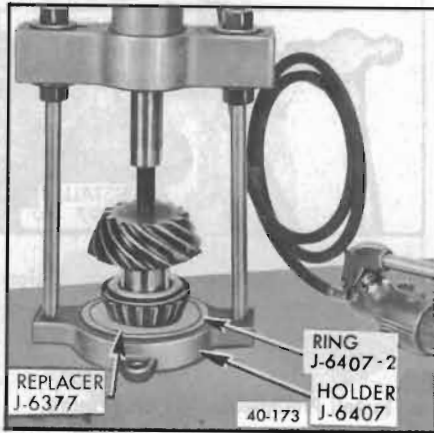

Figure 40-162—Installing Rear Pinion Bearing

5. Place front pinion bearing in position on pinion. Hold pinion fully forward and lightly drive bearing over pinion until seated. Use Installer J-21005. See Figure 40-164.

6. Install new "O" ring seal on pinion. Coat O.D. of new pinion seal with sealing compound and install seal using Installer J-21005. See Figure 40-165.

7. Coat lips of pinion oil seal and seal surface of pinion flange with gear lube. Install pinion flange on pinion by tapping with a soft hammer until a few pinion threads project through flange.

8. Install pinion washer and nut.



Figure 40-163—Installing Collapsible Spacer

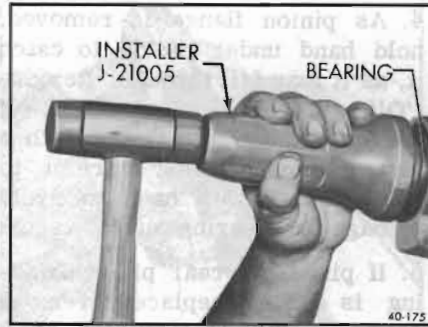

Figure 40-164—Installing Front Pinion Bearing

Hold pinion flange with Holder J-8614-01. While intermittently rotating pinion to seat bearings, tighten pinion nut until end play begins to be taken up. See Figure 40-166.

NOTE: When no further end play is detectable, and when Holder J-8614 will no longer pivot freely as pinion is rotated, preload specifications are being neared. Further tightening should be done only after preload has been checked.

9. Check preload by using an inch pound torque wrench as shown in Figure 40-167.

NOTE: After preload has been checked, final tightening should be done very cautiously. For example, if when checking, preload was found to be 5 inch pounds, additional tightening of the pinion nut as little as 1/8

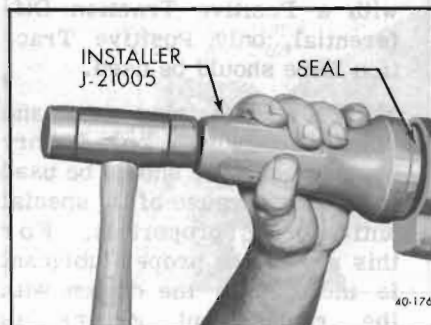

Figure 40-165—Installing Pinion Seal

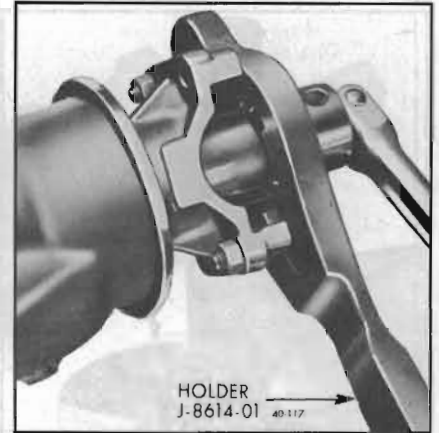

Figure 40-166—Installing Pinion Nut

turn can add 5 additional inch pounds drag. Therefore, the pinion nut should be further tightened only a little at a time and preload should be checked after each slight amount of tightening. Exceeding preload specifications will compress the collapsible spacer too far and require its replacement.

10. While observing the preceding note, carefully set preload drag at 25 to 30 inch pounds on new bearings or 10 to 15 inch pounds on used bearings.

11. Rotate pinion several times to insure that bearings have been seated. Check preload again. If drag has been reduced by rotating pinion, re-set preload to specifications.



Figure 40-167—Checking Preload

b. Pinion Setting Marks and Setting Gauges

All Buick ring and pinion gear sets are selectively matched for best operating position and proper tooth contact. After matching, a serial number is etched on both the pinion and the ring gear to aid in keeping matched parts together. Parts having different serial numbers must never be used together.

Ring and pinion gear sets are matched in a special test machine which permits adjustment of pinion depth in ring gear until a point is reached where best operation and proper tooth contact under load is obtained. At this point, the setting of the pinion with reference to the centerline of the ring gear is indicated by the machine. This setting may vary slightly from the design or "nominal" setting due to allowable variation in machining the parts. However, most production

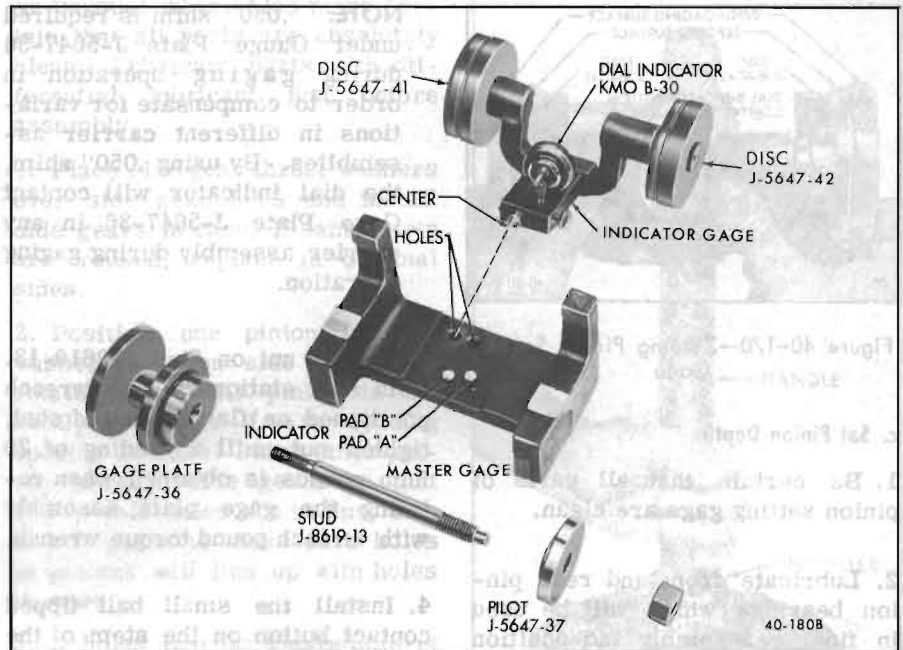

Figure 40-169—Pinion Setting Gauge

pinions and all pinions used for service replacement are zero or nominal pinions.

If during repair, a pinion is found having a plus or minus reading recorded in thousandths on the rear face of the pinion, this indicates that the pinion during testing was found to have best tooth contact at a position varying from design or nominal depth.

In order to compensate for all of the allowable machining variables, a procedure of gaging the carrier and shimming the pinion has been developed. After gaging a carrier, the assembler is able to install a shim between the front face of the pinion and its bearing so that pinion depth can be adjusted to an exact required specification for best tooth contact in each axle assembly.

Pinion Setting Gauge J-5647 with Discs J-5647-41 and 42, Pilot J-5647-37, Gage Plate J-5647-36, and Stud and Nut Assembly J-8619-13 is used to set pinion depth. See Figure 40-169. It is not necessary to reassemble and install the pinion depth setting shim since the pinion depth setting gage arrangement provides in effect, a nominal or zero pinion as a gaging reference.

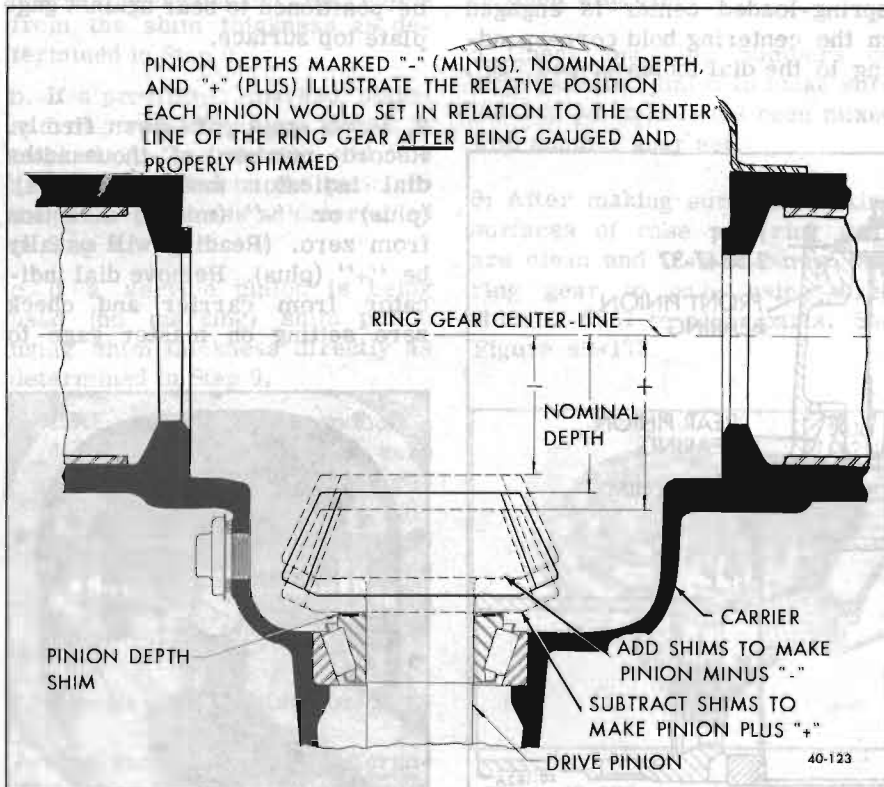

Figure 40-168—Nominal Pinion Setting Depth

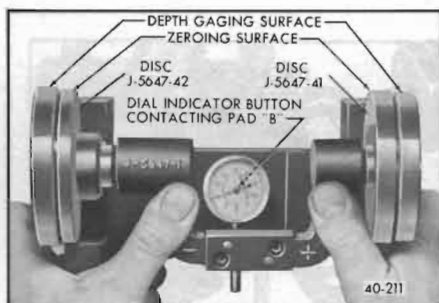

Figure 40-170—Zeroing Pinion Setting Gauge

c. Set Pinion Depth

1. Be certain that all parts of pinion setting gage are clean.

2. Lubricate front and rear pinion bearings which will be used in final reassembly and position them in their respective races in the carrier. Thread Stud J-8619-13 into Gage Plate J-5647-36. With bearings held in place in races, install a .050" shim and gage plate and stud assembly on rear pinion bearing inner race. Install Pilot J-5647-37 on front pinion bearing with small diameter on raised portion of bearing race. See Figure 40-171.

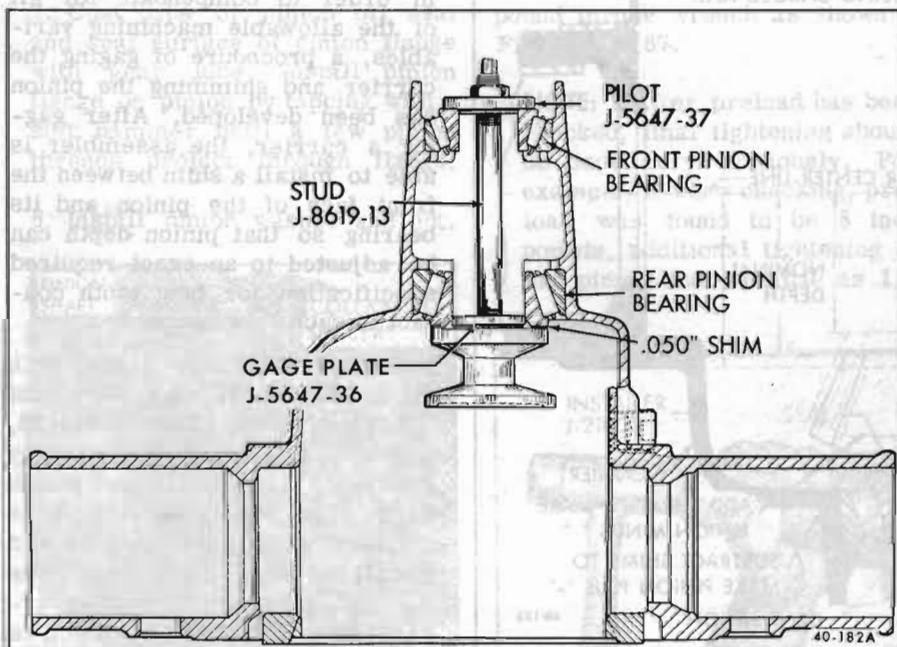

Figure 40-171—Installing Gage Plate in Carrier

NOTE: .050" shim is required under Gauge Plate J-5647-36 during gaging operation in order to compensate for variations in different carrier assemblies. By using .050" shim, the dial indicator will contact Gauge Plate J-5647-36 in any carrier assembly during gaging operation.

3. Install nut on Stud J-8619-13. Hold stud stationary with wrench positioned on flats on end of stud; tighten nut until a reading of 20 inch pounds is obtained when rotating the gage plate assembly with an inch pound torque wrench.

4. Install the small ball tipped contact button on the stem of the dial indicator and mount the dial indicator on the indicator gage. Install the discs on the indicator gage as shown in Figure 40-170.

5. Place the indicator gage on the master gage so that the spring-loaded center is engaged in the centering hold corresponding to the dial indicator pad "B".

6. Center the indicator contact button on the specified contact pad and lock the dial indicator by tightening the thumb screw.

7. With large diameter of Disc J-5647-41 and small diameter of Disc J-5647-42 contacting both the horizontal and vertical surfaces on the master gage, hold gage yoke down firmly with thumbs placed on indicator gage between arrow heads and unmachined portion of round disc support legs. Set dial indicator at zero.

8. Be certain that differential bearing support bores are free of dirt and burrs. Place indicator gage in carrier so that small diameter of Disc J-5647-41 and large diameter of Disc J-5647-42 rest in differential bearing pedestal support bores. Hold indicator gage as shown in Figure 40-172. Spring-loaded center of gage must be located in centering hole of gage plate, and ball-tipped contact button of dial indicator must be positioned to bear against gage plate top surface.

9. Press gage yoke down firmly. Record number of thousandths dial indicator moves in a "+" (plus) or "-" (minus) direction from zero. (Reading will usually be "+" (plus). Remove dial indicator from carrier and check zero setting on master gage to

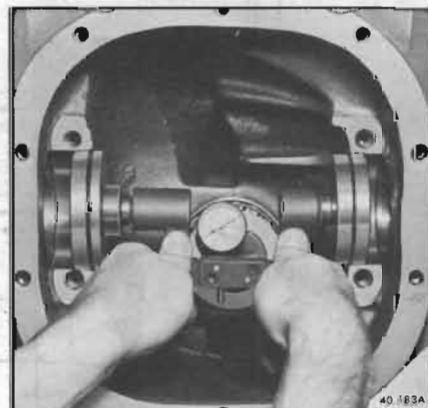

Figure 40-172—Checking Pinion Depth

make certain this setting was not disturbed by handling. If zero setting is still correct, remove gaging set-up (including 50 thousandths shim), then add a plus reading or subtract a minus reading from 50 thousandths. This answer indicates the thickness of the shims to be selected as further qualified in Step 11.

NOTE: The usual dial indicator reading will average from 1 to 10 thousandths in a plus direction with a corresponding shim thickness after computation of between 51 and 60 thousandths.

10. Examine ring gear and pinion for nicks, burrs or scoring. Any of these conditions will require replacement of the set.

11. The correct pinion shim to be used during pinion reassembly should be selected as follows:

a. If a production (marked) pinion is being reused and pinion is marked “+” (plus), subtract the amount specified on the pinion from the shim thickness as determined in Step 9.

b. If a production (marked) pinion is being reused and the pinion is marked “-” (minus), add the amount specified on the pinion to the shim thickness as determined in Step 9.

c. If a service pinion is being used (no marking) shim pinion using shim thickness directly as determined in Step 9.

NOTE: Frequently, production pinions are nominal or zero pinions (no marking). When reusing a nominal production pinion, shim as with service pinion using shim thickness directly as determined in Step 9.

d. Assemble Differential Case Assembly

Before assembling the differential, examine the wearing surfaces of all parts for scoring

or unusual wear. Also make certain that all parts are absolutely clean. Lubricate parts with differential lubricant just before assembly.

1. Place side gear thrust washers over side gear hubs and install side gears in case. If same parts are reused, replace in original sides.

2. Position one pinion (without washer) between side gears and rotate gear until pinion is directly opposite from loading opening in case. Place other pinion between side gears so that pinion axle holes are in line, then rotate gears to make sure holes in pinions will line up with holes in case.

3. If holes line up, rotate pinions back toward loading opening just enough to permit sliding in pinion thrust washers.

4. Install pinion axle. Drive pinion axle retaining pin through hole in case and pinion axle until pin is flush with case.

5. Check matching numbers on ring gear and pinion to make sure the two parts have not been mixed with another gear set.

6. After making sure that mating surfaces of case and ring gear are clean and free of burrs, bolt ring gear to case using three Studs J-6251 to align parts. See Figure 40-173.

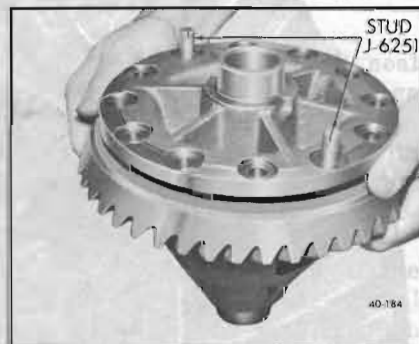

Figure 40-173—Installing Ring Gear on Differential Case

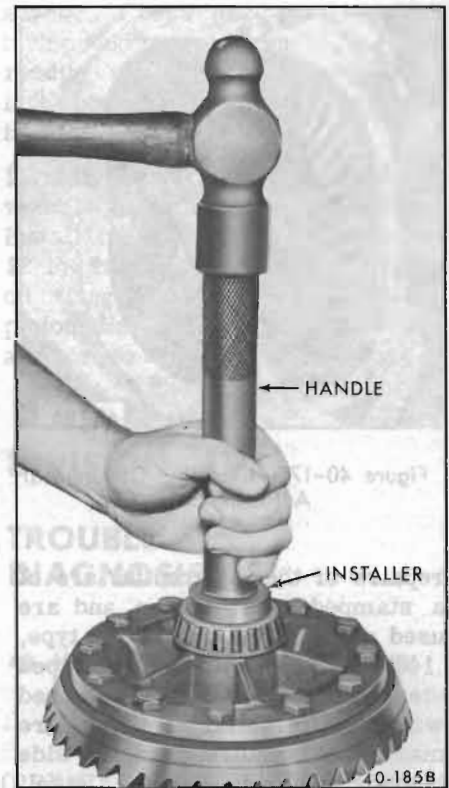

Figure 40-174—Installing Differential Side Bearings

Do not use lock washers or any substitute bolts.

7. First tighten bolts alternately on opposite sides of the case to 35 lb. ft. torque, then tighten in the same manner to 70 lb. ft.

8. If differential side bearings were removed, install new bearings using Installer J-22166 for right side or J-22539 for left side with Driver Handle J-8092. See Figure 40-174.

e. Install Differential Case and Adjust Side Bearing Preload

Differential side bearing preload is adjusted by changing the thickness of both the right and left shims by an equal amount. By changing the thickness of both shims equally, the original backlash will be maintained. All differential side bearing preload shims used in production are cast. Shims used during service

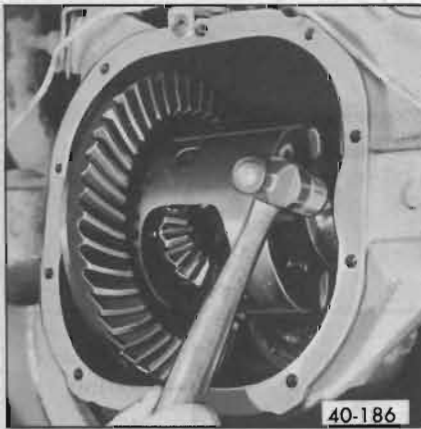

Figure 40-175—Installing Differential Adjusting Shims

repairs of the differential are of a stamped steel design and are used along with a production type, .140" thick, cast shim. Stamped steel service shims must be used when differential repairs are made that require changing side bearing preload. Service, steel, adjusting shims are available in thicknesses ranging from .040" to .082" in increments of .002".

1. Before installation of case assembly, make sure that side bearing surfaces in carrier are clean and free of burrs. Side bearings must be oiled with gear lube and if same bearings are being reused, they must have original outer races in place.

2. Place differential case and bearing assembly in position in carrier. Use service type adjusting shims totaling same thickness as production type adjusting shims if either new or reused bearings are to be used. Slip left shims in position at left bearing with steel shim next to bearing, then place .140" shim for right side in position and drive steel shim carefully into position between bearing and case shim using a soft hammer. See Figure 40-175.

Install side bearing caps, as previously marked and tighten bolts

to 53 lb. ft. before checking side bearing preload or backlash.

3. Rotate differential case assembly several complete turns to seat bearings. Check bearing preload using an inch pound torque wrench connected at pinion nut. Bearing preload should read 35-40 in. lbs. of rotating torque with new bearings or 20-25 in. lbs. of rotating torque with reused bearings. See Figure 40-167. If preload is not according to these specifications, increase shim thickness on each side .002" for each additional 10 in. lbs. preload desired or decrease shim thickness .002" on each side for each 10 in. lbs. preload to be subtracted.

f. Adjust Differential Backlash

1. Mount dial indicator as shown

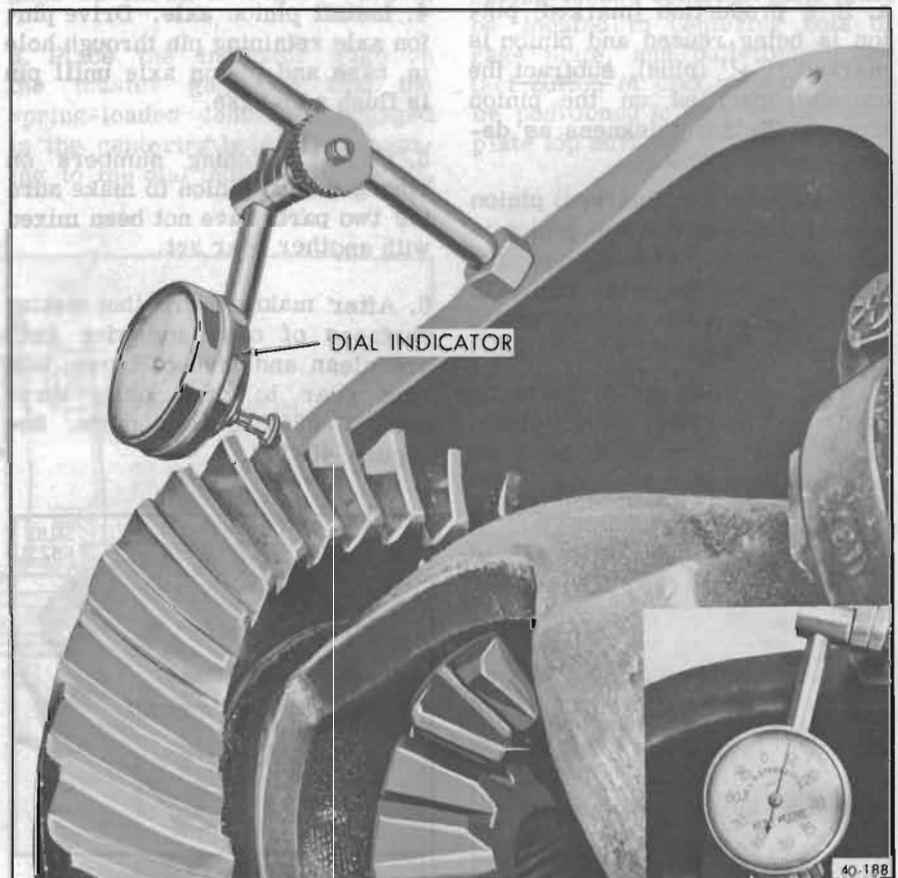

Figure 40-176—Checking Ring Gear to Pinion Backlash

in Figure 40-176. Use a small button on indicator stem so that contact can be made near heel end of tooth. Set dial indicator so that stem is as nearly as possible in line with gear rotation and perpendicular to tooth angle for accurate backlash reading.

2. With pinion locked to carrier, check gear lash at 3 or 4 points around ring gear. Lash must not vary over .001" around ring gear.

If variation is over .001" check for burrs, uneven bolting conditions or distorted case flange and make corrections as necessary.

3. Gear lash at the point of minimum lash should be .007", .008", or .009" when using new ring gear and pinion. Backlash should be adjusted as near as possible to .008".

If original gear set having a wear pattern is being reinstalled, original gear lash should be maintained with $\pm .001$ ".

NOTE: Some original gear sets may be as tight as .006", or as loose as .010". Either of these maximum limits are acceptable for original production gear sets only.

4. If gear backlash is not within specifications, correct by increasing thickness of one differential shim and decreasing thickness of other shim the same amount. In this way, correct differential bearing preload will be maintained.

Shift .002" in shim thickness for each .002" change in backlash desired. If backlash is .002" too much, decrease thickness of right shim .002" and increase thickness of left shim .002". If backlash is .002" too little, increase thickness of right shim .002" and decrease thickness of left shim .002".

5. Install new gasket on housing using heavy grease to retain gasket in place. Install cover. Torque cover bolts to 30 lb. ft. Wait 20 minutes and retorquer cover bolts to specifications.

6. Install axle shaft assemblies as described in paragraph 40-37.

7. Raise differential assembly and connect lower ends of both rear shock absorbers. Torque nuts to 45 lb. ft.

8. Align marks on rear universal joint and pinion flange. Install two U-bolts and torque to 12 lb. ft. (On 49000, align marks on flanged ball stud yoke and pinion flange. Install four bolts and torque to 85 lb. ft.)

9. Tighten parking brake cable and adjust as necessary.

10. Remove frame supports and lower car.

g. Install Pinion Oil Seal with Differential Installed in Car

1. Raise car and remove wheels and brake drums. Mark rear universal joint and pinion flange for proper alignment at reassembly. Then disconnect rear universal joint by removing two U-bolts. (On 49000, mark flanged ball stud yoke and rear pinion flange for proper alignment at reassembly. Then disconnect rear CV joint by removing four pinion flange bolts.) Push rear propeller shaft forward as far as possible, then wire it to the upper control arm frame bracket to support it out of the way.

2. Install an inch pound torque wrench on pinion nut and record torque required to rotate pinion freely.

3. Mark position of pinion flange, pinion shaft threads and pinion nut so that proper preload can be obtained at reassembly.

4. Remove pinion flange nut and washer using Holder J-8614-01 to hold flange.

5. Pry pinion oil seal out of assembly.

6. Examine surface of flange for nicks or damaged surface. If damaged, replace flange.

7. Examine carrier bore and remove any burrs that might cause leaks around O.D. of seal.

8. Coat O.D. of new pinion oil seal with sealing compound and install seal using Installer J-21005.

9. Coat lips of pinion oil seal with seal surface of pinion flange with gear lube. Install pinion flange on pinion by tapping with a soft hammer until a few pinion threads project through flange.

10. While holding pinion flange with Holder J-8614-01, install flange washer and nut. Tighten nut $1/8$ turn beyond alignment marks on pinion shaft threads in

order to preload collapsible spacer. Check preload using an inch pound torque wrench. Torque reading should be equal to or five inch pounds above that recorded in Step 2.

11. Align marks on rear universal joint and pinion flange. Install two U-bolts and torque to 12 lb. ft. (On 49000, align marks on flanged ball stud yoke and pinion flange. Install four bolts and torque to 85 lb. ft.)

DIVISION IV

TROUBLE DIAGNOSIS

40-40 PRE-REPAIR INVESTIGATION AND TROUBLE DIAGNOSIS

(PRE-REPAIR INVESTIGATION)

The pinion and ring gears must be completely assembled, installed and all preload and backlash adjustments completed prior to the start of this method of pinion depth setting. The following procedure can be used in place of the gage method of pinion depth setting.

A close examination of the differential prior to disassembly will often reveal valuable information as to the extent and type of repairs or adjustments necessary. The information thus gained, coupled with the report of malfunctioning will provide a basis for determining the degree of disassembly required. Since the frequent causes of axle noise are improper backlash, pinion bearing preload or side bearing preload, or a combination, a few simple adjustments may be all that is necessary to correct a problem.

Therefore, before removing the differential from the housing the following checks should be made

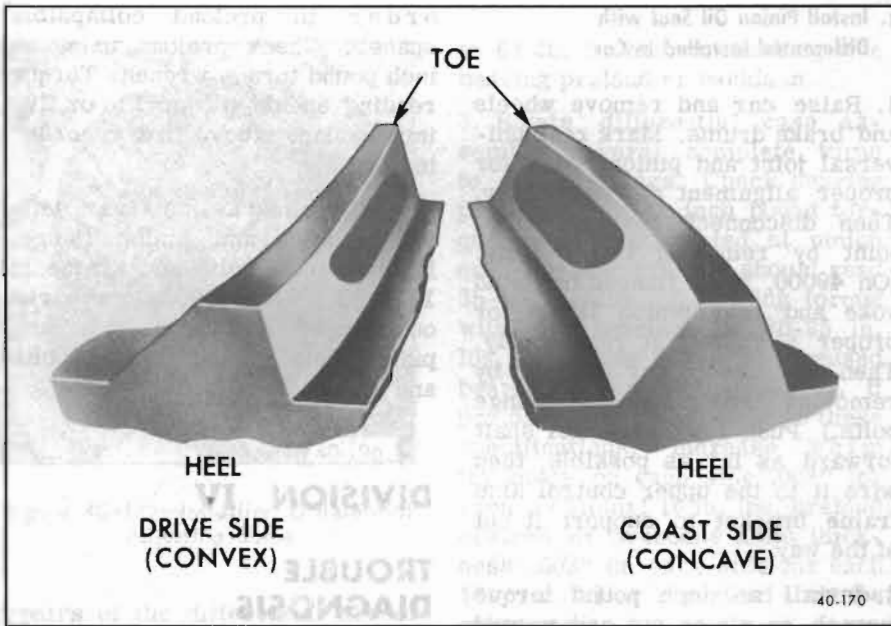

Figure 40-177—Gear Tooth Nomenclature

with the results recorded and analyzed; (1) Backlash, (2) Total Assembly Preload, (3) Red Lead Test.

Use care at all times to keep dirt and other foreign matter, such as grinder dust, soot or sand, away from differential to prevent possibility of subsequent failure.

a. Gear Tooth Nomenclature

The side of the ring gear tooth which curves outward, or is convex, is referred to as the "drive" side. The concave side is the "coast" side. The end of the tooth nearest center of ring gear is referred to as the "toe" end. The end of the tooth farthest away from center is the "heel" end. Toe end of tooth is smaller than heel end. It is very important that tooth contact be tested before the differential carrier assembly is disassembled. Variations in the carrier or pinion rear bearing may cause the pinion to be too far away from, or close to, the ring gear. Thus, the tooth contact must be tested and corrected if necessary, or the gears may be noisy.

b. Red Lead Test

1. Wipe oil out of carrier and carefully clean each tooth of ring gear.
2. Mix a small amount of powdered red lead (available from

paint manufacturers and suppliers) with a few drops of rear axle lubricant (until the powder is just moist) and apply this mixture sparingly to all ring gear teeth using a medium stiff brush. When properly used, the area of pinion tooth contact will be visible when hand load is applied.

3. Tighten bearing cap bolts to 53 lb. ft.

4. Wedge a piece of hardwood or fiber block between the ring gear and differential housing to load the ring gear against the pinion or apply parking brake to load the ring gear against the pinion. Apply sufficient load so that 70-100 ft. lbs. of rotating torque is required to turn pinion. Turn the pinion with a wrench on the pinion nut to establish a tooth contact pattern in the red lead.

A test made without loading the gears will not give a satisfactory pattern. Turn companion flange with wrench so that ring gear rotates one full revolution then reverse rotation so that ring gear

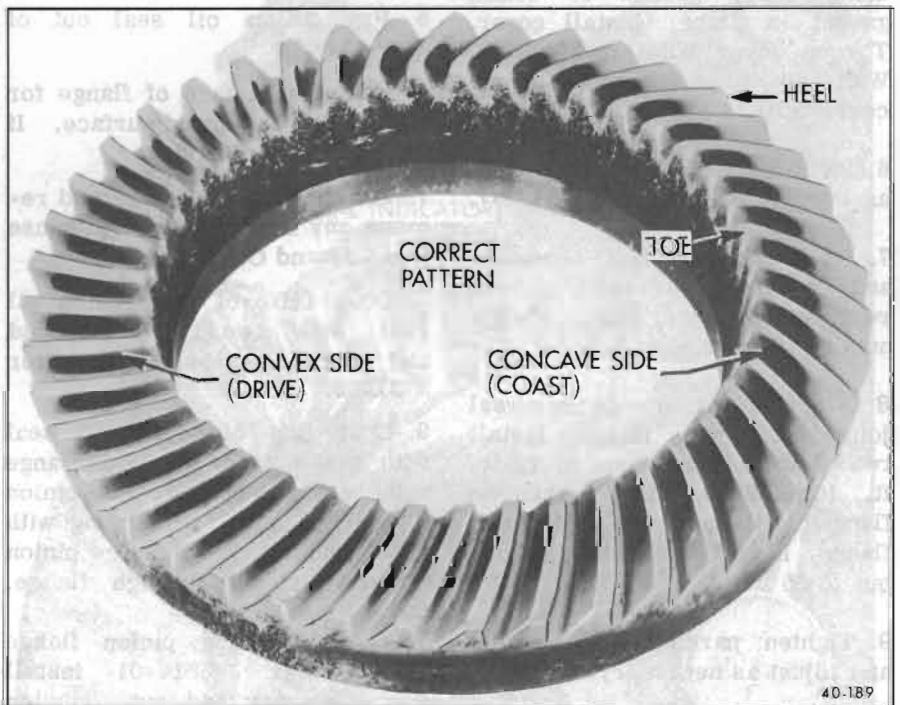

Figure 40-178—Desired Tooth Contact Under Light Load

rotates one revolution in opposite direction. Excessive turning of ring gear may indicate good tooth pattern because one or two teeth are making proper contact.

5. Observe pattern on ring gear teeth and compare with Figures 40-177 and 178.

c. Effects of Increasing Load on Tooth Contact Pattern

When "load" on ring and pinion gear is increased, such as when car is accelerated forward from standstill or from normal drive, the tooth contact will tend to spread out, and under very heavy load will extend from near toe to near heel on the drive side. The entire contact also tends to shift toward heel under increasingly heavier loads and will become somewhat broader with respect to tops and bottoms of teeth. The patterns obtained by red lead tests, dependent upon degree of "loading", approximate a normal light load. For this reason, they will extend only about halfway.

The important thing to note is that the contact pattern is centrally

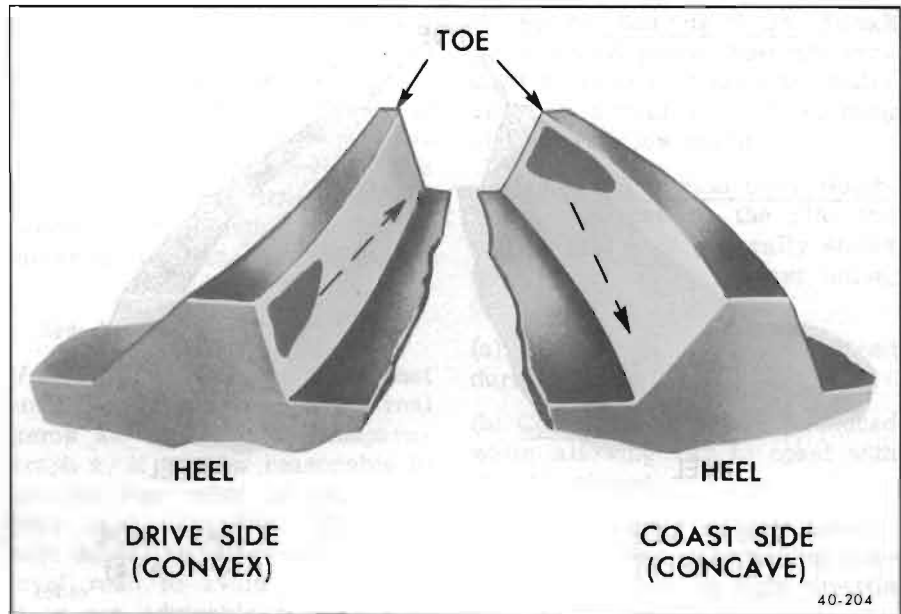

Figure 40-180—Effect on Pattern as Shim Thickness is Increased

located up and down on the face of the ring gear teeth.

d. Adjustments Effecting Tooth Contact

Two adjustments can be made which will affect tooth contact pattern - backlash, and position of drive pinion in carrier. The ef-

fects of bearing preloads are not readily apparent on (hand loaded) red lead tests; however, these adjustments should be within specifications before proceeding with backlash and drive pinion adjustments.

Backlash is adjusted by means of the side bearing adjusting shims which moves the entire case and ring gear assembly closer to, or farther from, the drive pinion. (The adjusting shims are also used to set side bearing preload.)

The position of the drive pinion is adjusted by increasing or decreasing the shim thickness between the pinion head and inner race of rear bearing. The shim is used in the differential to compensate for manufacturing tolerances. Increasing shim thickness will move the pinion closer to centerline of the ring gear. Decreasing shim thickness will move pinion farther away from centerline of the ring gear.

e. Effects of Pinion Position on Tooth Pattern

When the drive pinion is too far away from centerline of the ring

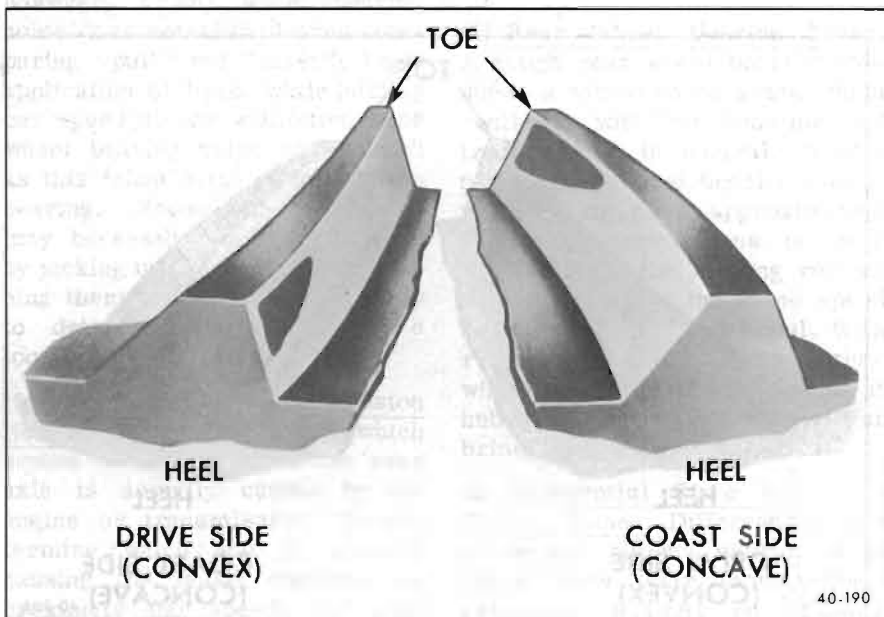

Figure 40-179—Tooth Pattern - Pinion too far away from Ring Gear (Shim Thickness Insufficient)

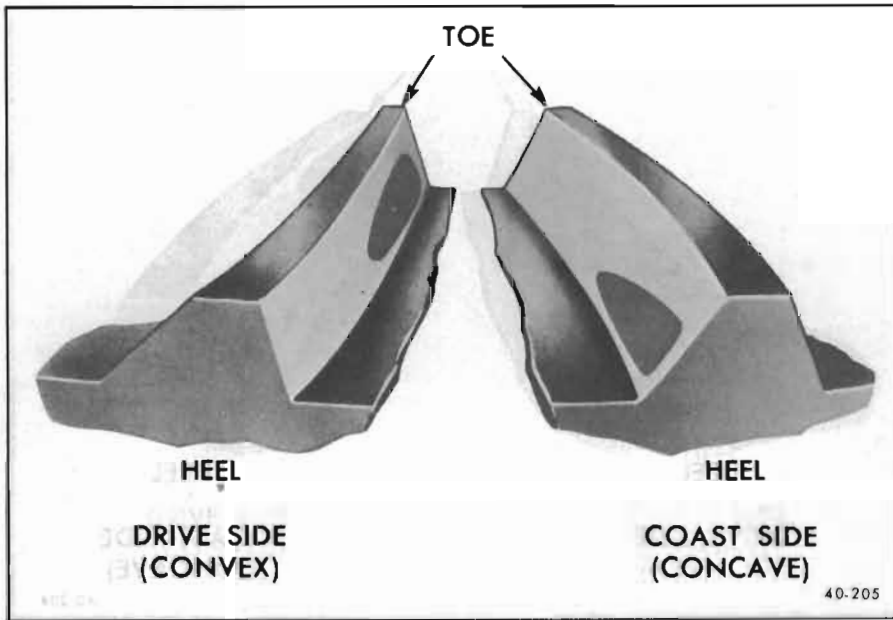

Figure 40-181—Tooth Pattern - Pinion too close to Ring Gear (Shim Thickness Excessive)

gear, the pattern will be a high heel contact on drive side and high toe contact on coast side, provided backlash is within specifications of .007", .008", .009". See Figure 40-179. Moving the pinion closer to centerline of the ring gear by increasing shim thickness will cause the high heel contact on drive side to lower and move toward the toe; the high toe contact on coast side will lower and move toward the heel. See Figure 40-180.

When the pinion is too close to the centerline of the ring gear, the pattern will be a low toe contact on drive side, and a low heel contact on coast, provided backlash is within specifications. See Figure 40-181. Moving the pinion farther away from the ring gear by decreasing shim thickness will cause low toe contact on drive side to raise and move toward the heel; the low heel contact on coast side will raise and move toward the toe. See Figure 40-182.

NOTE: Whenever the rear axle is overhauled to the point of requiring a new ring gear and

pinion set, the rear axle should be filled **ONLY** with the lubricant included with the gear set. Whenever the rear axle is overhauled to the point of requiring only pinion and/or side bearings, it is recommended that lubricant 5.535 - 1050081 be used to refill for positive

traction units or 5.535 - 1388901 for regular units.

(TROUBLE DIAGNOSIS)

a. Elimination of External Noises

When a rear axle is suspected of being noisy it is advisable to make a thorough test to determine whether the noise originates in the tires, road surface, front wheel bearings, engine, transmission, or rear axle assembly. Noise which originates in other places cannot be corrected by adjustment or replacement of parts in the rear axle assembly.

(1) **Road Noise.** Some road surfaces, such as brick or rough surfaced concrete, cause noise which may be mistaken for tire or rear axle noise. Driving on a different type of road, such as smooth asphalt or dirt, will quickly show whether the road surface is the cause of noise. Road noise usually is the same on drive or coast.

(2) **Tire Noise.** Tire noise may easily be mistaken for rear axle noise even though the noisy tires may be located on the front

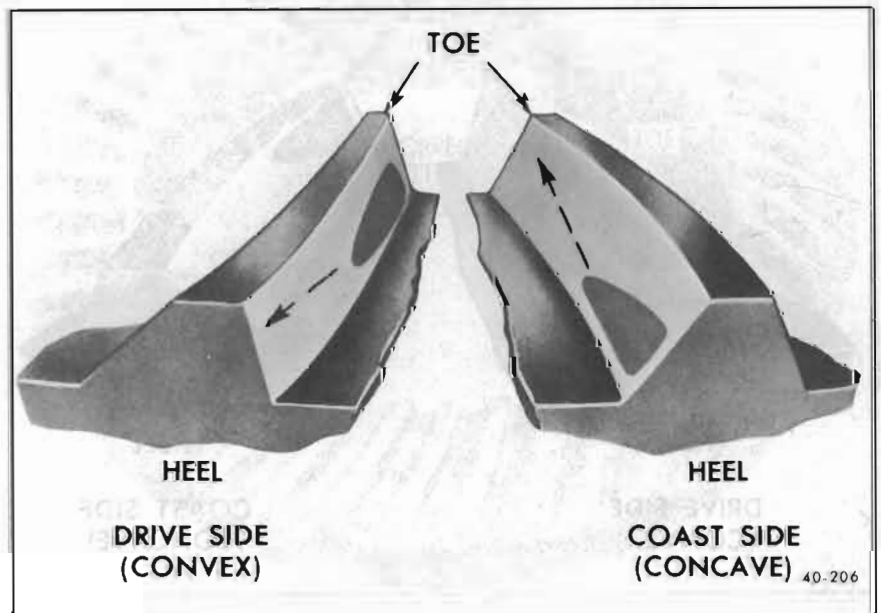

Figure 40-182—Effect on Tooth Pattern as Shim Thickness is Decreased

wheels. Tires worn unevenly or having surfaces on non-skid divisions worn in saw-tooth fashion are usually noisy, and may produce vibrations which seem to originate elsewhere in the vehicle. This is particularly true with low tire pressure. Some designs of non-skid treads may be more noisy than others, even when tires are new.

(3) Test for Tire Noise. Tire noise changes with different road surfaces, but rear axle noise does not. Temporarily inflating all tires to approximately 50 pounds pressure, for test purposes only, will materially alter noise caused by tires, but will not affect noise caused by rear axle. Rear axle noise usually ceases when coasting at speeds under 30 miles per hour; however, tire noise continues but with lower tone as car speed is reduced. Rear axle noise usually changes when comparing "pull" and "coast," but tire noise remains about the same.

(4) Front Wheel Bearing Noise. Loose or rough front wheel bearings will cause noise which may be confused with rear axle noises; however, front wheel bearing noise does not change when comparing "pull" and "coast". Light application of brake while holding car speed steady will often cause wheel bearing noise to diminish as this takes some weight off the bearing. Front wheel bearings may be easily checked for noise by jacking up the wheels and spinning them, also by shaking wheels to determine if bearings are loose.

(5) Engine and Transmission Noises. Sometimes a noise which seems to originate in the rear axle is actually caused by the engine or transmission. To determine which unit is actually causing the noise, observe approximate car speeds and conditions under which the noise is most pronounced; then stop car in a quiet place to avoid inter-

fering noises. With transmission in neutral, run engine slowly up and down through engine speeds corresponding to car speed at which the noise was most pronounced. If a similar noise is produced with car standing, it is caused by the engine or transmission, and not the rear axle.

b. Rear Axle Noises

If a careful test of car shows that noise is not caused by external items as described in subparagraph a, it is then reasonable to assume that noise is caused by rear axle assembly. The rear axle should be tested on a smooth level road to avoid road noise. It is not advisable to test rear axle for noise by running with rear wheels jacked up.

Noises in rear axle assembly may be caused by a faulty propeller shaft, faulty rear wheel bearings, faulty differential or pinion shaft bearings, misalignment between two U-joints, or worn differential side gears and pinions; noises may also be caused by mismatched, improperly adjusted, or scored ring and pinion gear set.

(1) Rear Wheel Bearing Noise. A rough rear wheel bearing produces a vibration or growl which continues with car coasting and transmission in neutral. A brinelled rear wheel bearing causes a knock or click approximately every two revolutions of rear wheel, since the bearing rollers do not travel at the same speed as the rear axle and wheel. With rear wheels jacked up, spin rear wheels by hand while listening at hubs for evidence of rough or brinelled wheel bearing.

(2) Differential Side Gear and Pinion Noise. Differential side gears and pinions seldom cause noise since their movement is relatively slight on straight ahead driving. Noise produced by these gears will be most pronounced on turns.

(3) Pinion Bearing Noise. Rough or brinelled pinion bearings produce a continuous low pitch whirring or scraping noise starting at relatively low speed.

(4) Ring and Pinion Gear Noise. Noise produced by the ring and pinion gear set generally shows up as drive noise, coast noise, or float noise.

(a) Drive noise is noise produced during vehicle acceleration.

(b) Coast noise is noise produced while allowing car to coast with throttle closed.

(c) Float noise is noise occurring while just maintaining constant car speed at light throttle on a level road.

(d) Drive, coast, and float noises will vary in tone with speed, and will be very rough and irregular if the differential or pinion shaft bearings are rough, worn, or loose.

c. Body Boom Noise or Vibration

Objectional "body boom" noise or vibration at 55-65 MPH can be caused by an unbalanced propeller shaft. Excessive looseness at the spline can contribute to this unbalance.

Other items that may also contribute to the noise problem are as follows:

1. Undercoating or mud on the shaft causing unbalance.
2. Shaft balance weights missing.
3. Shaft damage such as bending, dents or nicks.
4. Tire-type roughness. Switch tires from a known good car to determine tire fault.

d. Check for Propeller Shaft Vibration

Objectionable vibrations at high speed (65 MPH or higher) may be caused by a propeller shaft that

is out of balance. Out of balance may be due to a bent shaft.

To determine whether propeller shaft is causing vibration, drive car through speed range and note speed at which vibration is most pronounced. Shift transmission into lower gear range and drive car at same engine speed as when vibration was most pronounced in direct drive. Note effect on vibration.

To determine engine speed, divide vehicle speed by the following transmission gear ratios as listed below:

Three speed manual in second gear, divide by 1.61; S.T. 400 in low range, divide by 1.50.

EXAMPLE: If vibration is most pronounced in direct drive

at 65 MPH, the same engine speed would be produced in second gear (three speed manual) at $65/1.61 = 40$ MPH; in low range (S.T. 400) at $65/1.50 = 43$ MPH.

If the vibration is still present at the same engine speed whether in direct drive or in the lower gear, since the propeller shaft speed varies, this cannot be the fault. If the vibration decreases or is eliminated in the lower gear, then the propeller shaft is out of balance and should be re-balanced. See Section D for balancing procedure and more complete trouble diagnosis.

e. Oil Leaks

It is difficult to determine the source of some oil leaks. When

there is evidence of an oil leak, determine source as follows:

(1) Oil coming from the drain hole under the axle housing at the brake backing plate is caused by a leaking axle shaft seal or a leaking wheel bearing inner gasket.

(2) Oil coming from between the rear pinion flange slinger and the carrier is caused by a leaking pinion seal.

Even after the point of leakage has been determined, it is hard to tell whether the oil is leaking past the lip of the seal or past the O.D. of the seal. Therefore it is a good idea to make sure the leak is stopped by using a non-hardening sealing compound around the O.D. of the new seal.

(1) Front Wheel Bearing Noise
A rough rear wheel bearing produces a vibration or growl which continues with car coasting and transmission in neutral. A dull, rattle or click approximately every two revolutions of rear wheel, while the bearing rollers are not engaged, is the same speed as the rear wheel and axle. With the vehicle in gear, the noise is produced by the propeller shaft.

(2) Differential Side Gear and Pinion Noise
Differential side gears and pinions, without cause noise since their movement is relatively slight on straight ahead driving. Noise produced by these gears will be most pronounced at high speeds.

(A) Front Wheel Bearing Noise
A rough front wheel bearing produces a vibration or growl which continues with car coasting and transmission in neutral. A dull, rattle or click approximately every two revolutions of front wheel, while the bearing rollers are not engaged, is the same speed as the front wheel and axle. With the vehicle in gear, the noise is produced by the propeller shaft.

(3) Differential Side Gear and Pinion Noise
Differential side gears and pinions, without cause noise since their movement is relatively slight on straight ahead driving. Noise produced by these gears will be most pronounced at high speeds.

(B) Front Wheel Bearing Noise
A rough front wheel bearing produces a vibration or growl which continues with car coasting and transmission in neutral. A dull, rattle or click approximately every two revolutions of front wheel, while the bearing rollers are not engaged, is the same speed as the front wheel and axle. With the vehicle in gear, the noise is produced by the propeller shaft.

NOTE
Vibration at high speeds (65 MPH or higher) may be caused by a propeller shaft imbalance.