

SECTION E

43-44-45000 STANDARD DIFFERENTIAL

CONTENTS

Division	Paragraph	Subject	Page
I	40-21	SPECIFICATIONS AND ADJUSTMENTS: Differential Specifications	40-56
II	40-22	DESCRIPTION AND OPERATION: Description and Operation of Standard Differential	40-57
III	40-23 40-24 40-25 40-26	SERVICE PROCEDURES: Removal and Installation of Differential Assembly Removal and Installation of Axle Shaft, Wheel Bearing or Oil Seal Removal and Disassembly of Differential Case Assembly Assembly and Installation of Differential Case Assembly	40-60 40-61 40-62 40-64
IV	40-27	TROUBLE DIAGNOSIS: Pre-Repair Investigation and Trouble Diagnosis	40-70

DIVISION I SPECIFICATIONS AND ADJUSTMENTS

40-21 DIFFERENTIAL SPECIFICATIONS

a. Tightening Specifications

Use a reliable torque wrench to tighten the parts listed, to insure proper tightening without straining or distorting parts. These specifications are for clean and lightly lubricated threads only; dry or dirty threads produce increased friction which prevents accurate measurement of tightness.

Part	Location	Thread Size	Torque Lbs. Ft.
Nut	Rear Universal Joint to Pinion Flange	5/16-18	12
Bolt	Differential Pinion Shaft Locking Bolt	5/16 (Special)	24
Bolt	Rear Axle Housing Cover to Carrier	5/16-18	30
Nut	Brake Assembly to Rear Axle Housing	3/8 -16	35
Bolt	Ring Gear to Differential Case (43-44-45000 exc. G.S. 400 and Sportwagon)	3/8 -24	55
Bolt	Ring Gear to Differential Case (G.S. 400 and Sportwagon)	7/16-20	85
Bolt	Bearing Cap to Carrier	7/16-14	53
Nut	Rear Wheel to Axle Shaft	7/16-20	65
*Nut	Upper and Lower Control Arm	1/2 -13	80
*Bolt	Upper and Lower Control Arm	1/2 -13	110
*Nut & Bolt	Upper Control Arm Vernier Adjustment (49000)	7/16-14	48
Nut	Lower End of Shock Absorber to Lower Control Arm Axle Bracket	1/2 -20	45

*Torquing of Nut or Bolt to be optional.

b. General Specifications

Rear Axle Type	Semi-Floating Hypoid
Drive and Torque	Through 4 Arms
Rear Axle Oil Capacity	2-3/4 pints
Ring and Pinion Gear Set Type	Hypoid

c. Limits for Fitting and Adjusting

Pinion Bearing Preload (Measured at pinion flange nut)	
New Bearings	25-30 inch lbs. rotating torque with new seal
Reused Bearings	10-15 inch lbs. rotating torque with new seal
Total Assembly Preload (Measured at pinion flange nut)	
New Bearings	35-40 inch lbs. rotating torque with new seal, with ring gear
Reused Bearings	20-25 inch lbs. rotating torque with new seal, with ring gear
Ring Gear Position	.007", .008", .009" Backlash

d. Differential Gear Ratios

Gear ratios are indicated by letters stamped on the bottom of the right axle tube. The production date is also indicated by a stamped number which represents the day of the year starting with "1" for January 1. See Figure 40-90.

centerline of the pinion below the centerline of the ring gear. See Figures 40-91 and 40-92.

The drive pinion is mounted in two tapered roller bearings which are preloaded by a collapsible spacer during assembly. The pinion is positioned by shims located

between a shoulder on the drive pinion and the rear bearing. The front bearing is held in place by a large nut.

The differential is supported in the carrier by two tapered roller side bearings. These are preloaded by inserting shims between

e. Speedometer Gears

Speedometer gears must correspond with axle ratios and tire sizes in order to have correct speedometer and odometer readings.

DIVISION II

DESCRIPTION AND OPERATION

40-22 DESCRIPTION AND OPERATION OF STANDARD DIFFERENTIAL

The rear axle assembly is of the semi-floating type in which the car weight is carried on the axle shafts through ball bearings enclosed in the outer axle housing tubes. The rear axle is designed for use with an open drive line and coil springs. Drive from the axle housing is transmitted to frame members through two lower and two upper control arms. Large rubber bushings at either end of these control arms are designed to absorb vibration and noise. The upper control arms are angle mounted to also hold the frame in sidewise alignment with the rear axle assembly. The final drive has a hypoid type ring gear and pinion with the

AXLE RATIO	SERIES							
	43.44000 EXCEPT SPORTWAGON AND 44600		44000 SPORT-WAGON		44600		45000	
	STD. AXLE	P.T. AXLE	STD. AXLE	P.T. AXLE	STD. AXLE	P.T. AXLE	STD. AXLE	P.T. AXLE
2.56	LK	—	—	—	—	—	—	—
2.78	LA	LN	—	—	—	—	NL	NY
2.93	OB	OW	—	—	OE	OX	NJ	NZ
3.23	LC	LP	MG	MT	—	—	—	—
3.36	—	LX	—	—	LJ	LX	NG	NU
3.55	—	OR	—	MW	—	OR	—	—
3.90	—	OS	—	MX	—	OS	—	NX
4.30	—	—	—	—	—	OT	—	—

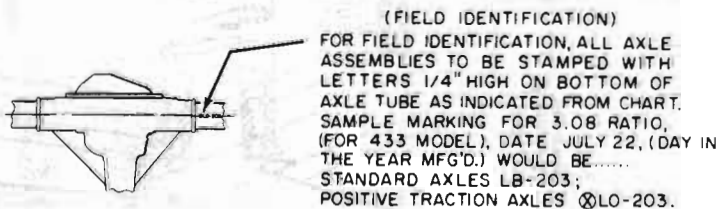

40-120A

Figure 40-90—Differential Identification

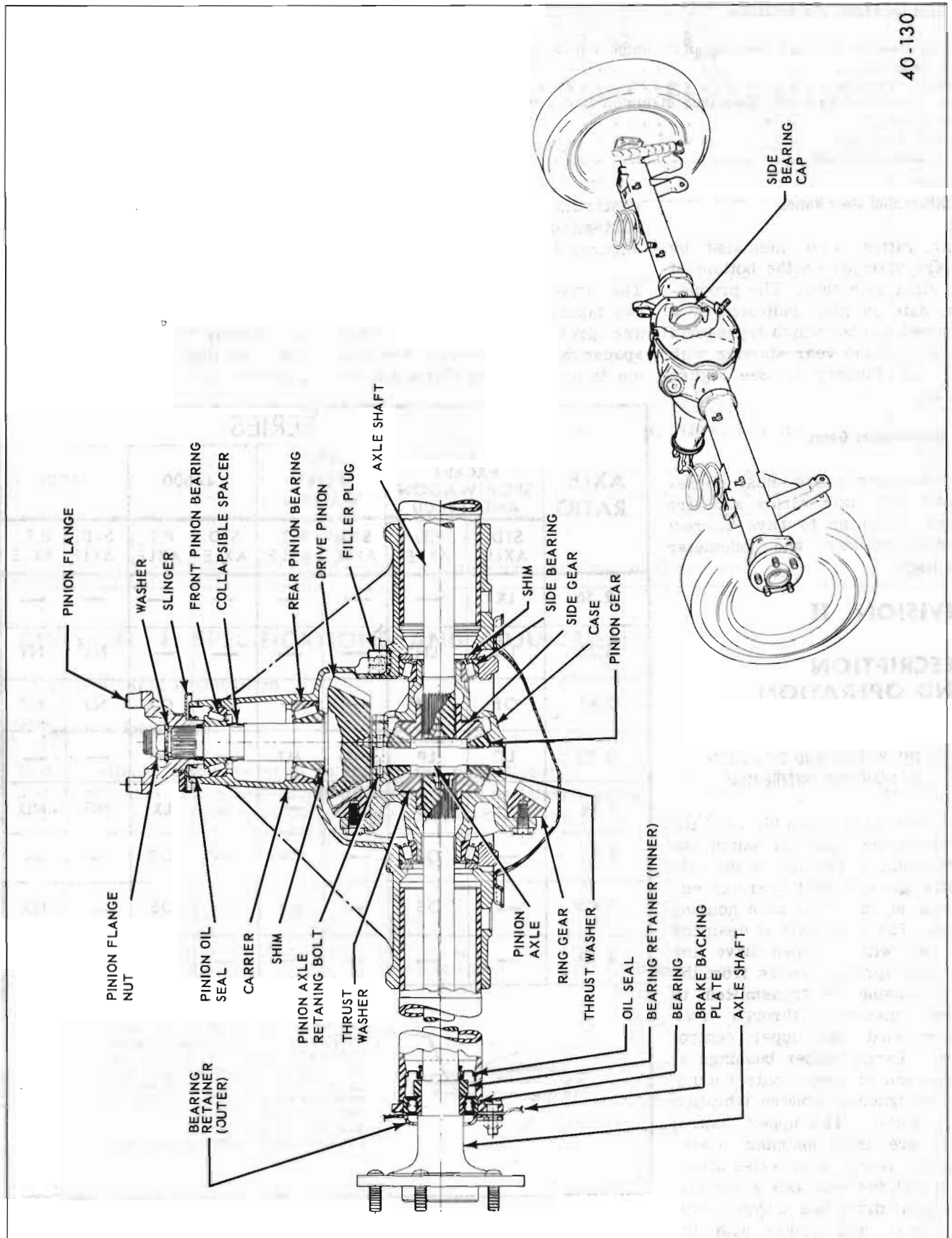
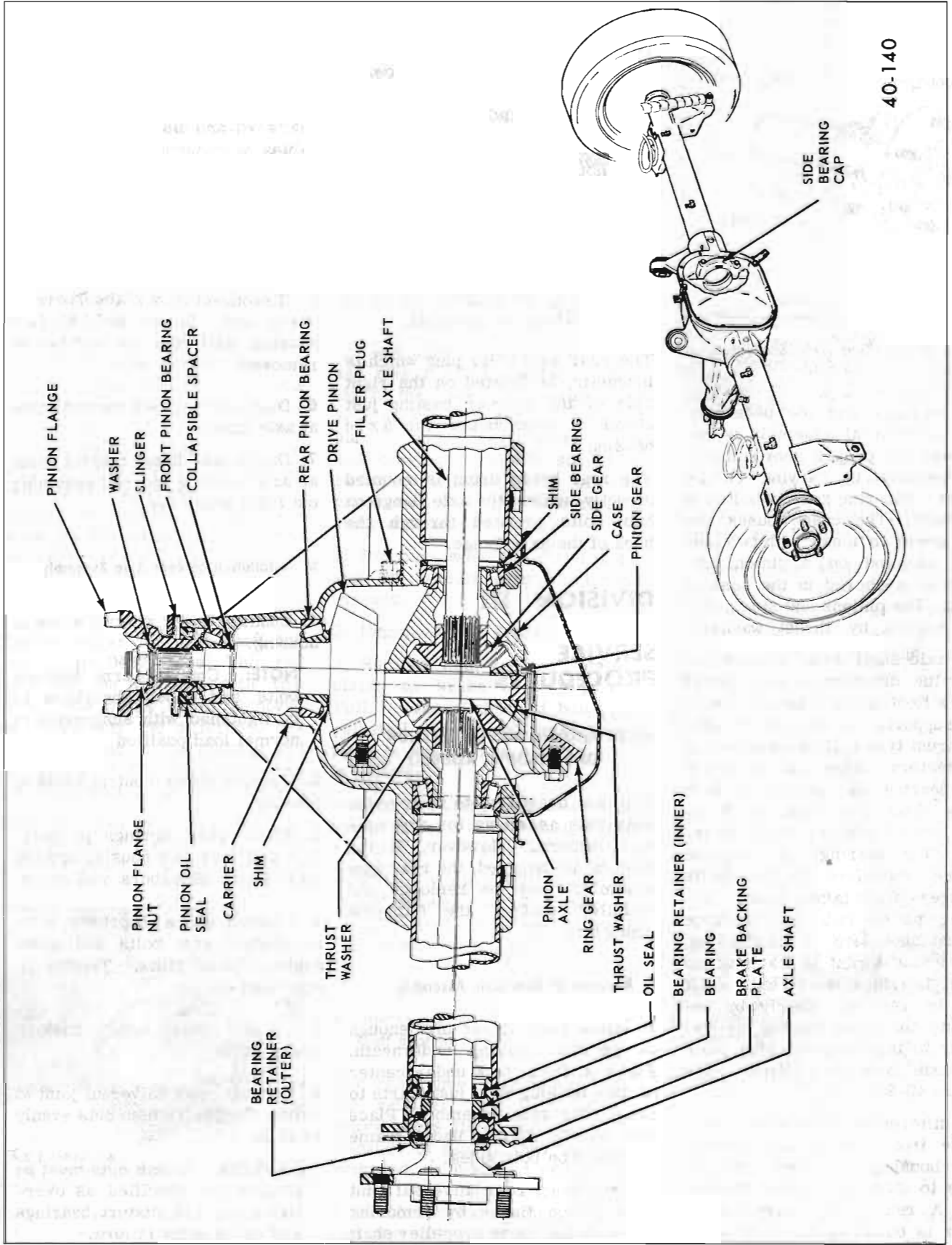

Figure 40-91 43-44000 Differential Assembly



40-140

Figure 40-92 45000 Differential Assembly

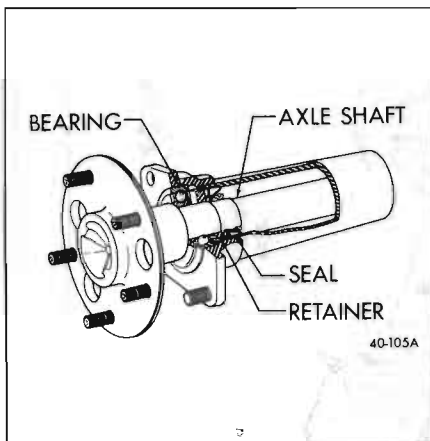

Figure 40-93—Rear Axle Shaft Bearing and Seal

the bearings and the pedestals. The differential assembly is positioned for proper gear and pinion backlash by varying these shims. The ring gear is bolted to the case. The case houses two side gears in mesh with two pinions mounted on a pinion axle which is anchored in the case by a bolt. The pinions and side gears are backed by thrust washers.

The axle shaft inner splines engage the differential side gears with a floating fit. The outer ends are supported in the axle housing by thrust type ball bearings which are factory packed for the life of the bearing and sealed on both sides. The axle shaft oil seals are located inboard of the bearings. The bearings are secured against shoulders on the shafts by press fit retainer rings. Retainer plates hold the bearings against shoulders in the housing. Wheel side thrust is taken at the wheel bearings, so an axle shaft may be removed simply by removing the bolts holding the retainer to the brake backing plate and axle housing flange. See Figure 40-93.

The differential carrier is a malleable iron casting with tubular axle housings pressed into the sides to form a complete assembly. A removable, heavy steel cover is bolted on the rear of the

carrier to permit service of the differential without removing the rear axle from the car. A seal in the front of the carrier bears against the pinion flange. See Figures 40-91 and 40-92.

Brackets welded to the tubular axle housings and upper brackets integral with main carrier casting, form means of attaching the rear axle to the frame. An oil feed passage to the pinion bearings and an oil return hole are provided in the carrier casting to allow lubricant to circulate.

The rear axle filler plug which is magnetic, is located on the right side of the carrier casting just ahead of and below the axle housing.

The rear brake drum is mounted directly against the axle flange on hub bolts pressed through the back of the axle flange.

DIVISION III

SERVICE PROCEDURES

40-23 REMOVAL AND INSTALLATION OF DIFFERENTIAL ASSEMBLY

It is not necessary to remove the rear axle assembly for any normal repairs. However, if the housing is damaged, the rear axle assembly may be removed and installed using the following procedure.

a. Removal of Rear Axle Assembly

1. Raise rear of car high enough to permit working underneath. Place a floor jack under center of axle housing so it just starts to raise rear axle assembly. Place jack stands solidly under frame members on both sides.

2. Disconnect rear universal joint from pinion flange by removing two U-bolts. Wire propeller shaft

to exhaust pipe to support it out of the way.

3. Disconnect parking brake cables by removing adjusting nuts at equalizer. Slide center cable rearward and disconnect two rear cables at connectors to free from body.

4. Disconnect rear brake hose at floor pan. Cover brake hose and pipe openings to prevent entrance of dirt.

5. Disconnect shock absorbers at lower end. Lower jack under housing until rear springs can be removed.

6. Disconnect upper control arms at axle ends.

7. Disconnect lower control arms at axle housing and roll assembly out from under car.

b. Installation of Rear Axle Assembly

1. Connect lower control arms to housing.

NOTE: Control arm bushing bolts and shock absorbers to be tightened with suspension in normal load position.

2. Connect upper control arms to housing.

3. Place rear springs in position and jack axle housing upward until shock absorbers will reach.

4. Connect shock absorbers, lower control arm bolts and upper control arm bolts. Tighten to specified torque.

5. Connect and adjust parking brake cable.

6. Connect rear universal joint to pinion flange. Tighten nuts evenly to 12 lb. ft.

CAUTION: U-bolt nuts must be torqued as specified as over-tightening will distort bearings and cause early failure.

7. Connect rear brake hose at floor pan. Bleed both rear brakes and refill master cylinder.

8. Fill rear axle with specified gear lubricant. If axle housing or any rear suspension parts were replaced due to damage, rear universal joint angle must be checked (and adjusted if necessary on 45000).

40-24 REMOVAL AND INSTALLATION OF AXLE SHAFT, WHEEL BEARING OR OIL SEAL

Most rear axle service repairs can be made with the rear axle assembly in the car by raising the rear end of the car with the rear axle hanging on the shock absorbers. See Figure 40-94. Rear axle lubricant may be drained by backing-out all cover bolts and breaking cover loose at the bottom.

a. Remove Axle Shaft Assemblies

Design allows for axle shaft end play up to .042" loose. This end play can be checked with the wheel and brake drum removed by measuring the difference between the end of the housing and the axle shaft flange while moving the axle shaft in and out by hand.

End play over .042" is excessive. Compensating for all of the end play by inserting a shim inboard



Figure 40-94—Differential Assembly in Position for Repair

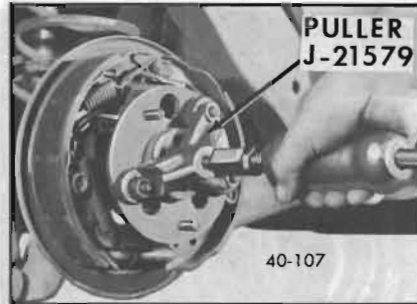

Figure 40-95—Removing Rear Axle Shaft

of the bearing in the housing is not recommended since it ignores the end play of the bearing itself, and may result in improper seating of the gasket or backing plate against the housing. If the end play is excessive, the axle shaft and bearing assembly should be removed and the cause of the excessive end play determined and corrected.

1. Remove wheels. Both right and left wheels have right hand threads.
2. Remove brake drums.
3. Remove nuts holding retainer plates to brake backing plates. Pull retainers clear of bolts and reinstall two opposite nuts finger tight to hold brake backing plate in position.
4. Pull out axle shaft assemblies using Puller J-21579 with a slide hammer. See Figure 40-95.

NOTE: While pulling axle shaft out through oil seal, support shaft carefully in center of seal to avoid cutting seal lip.

b. Remove and Install Axle Shaft Bearing

The rear wheel bearing and bearing retainer ring both have a heavy press fit on the axle shaft. Because of this fit they should be removed or installed separately.

1. Notch bearing retainer in 3 or 4 places with a chisel deep enough

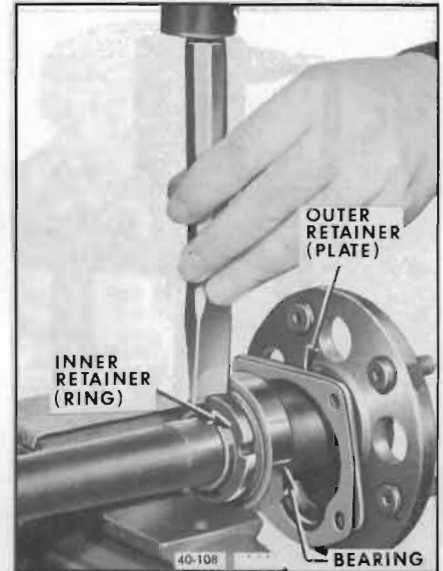

Figure 40-96—Removing Axle Shaft Bearing Retainer

to spread ring. Retainer will then slip off. See Figure 40-96.

2. Press axle shaft bearing off using Puller Plate J-8621 with Remover J-6525. An arbor press may be used or a set-up may be made using Ram and Yoke Assembly with Adapter J-6258 and puller J-21579. See Figure 40-97.

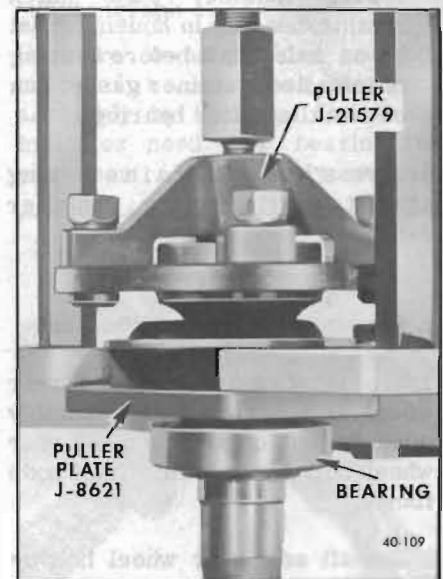

Figure 40-97—Removing Axle Shaft Bearing

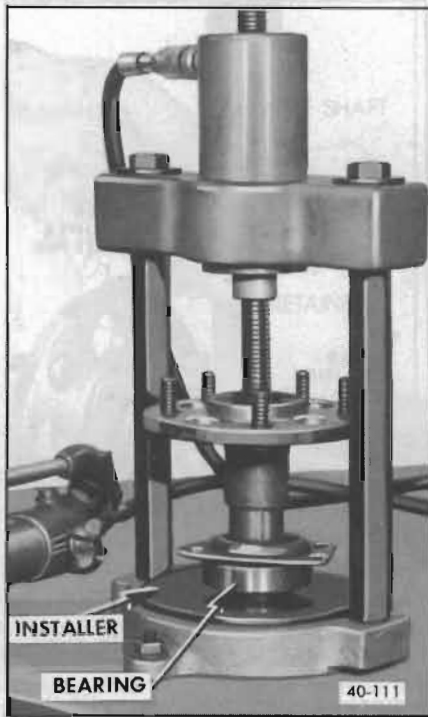

Figure 40-98—Installing Axle Shaft Bearing

3. Press new bearing against shoulder on axle shaft using Installer J-8853 with Holder J-6407. See Figure 40-98.

NOTE: Retainer plate which retains bearing in housing must be on axle shaft before bearing is installed; retainer gasket can be installed after bearing.

4. Press new retainer ring against bearing using Installer J-8853.

c. Remove and Install Rear Wheel Bolt

1. To remove and install a rear wheel bolt, axle shaft assembly must be out of car. Remove rear wheel bolt by pressing from axle flange.

2. Install new rear wheel bolt by pressing through axle flange. Check new bolt for looseness; if bolt is loose, axle shaft must be replaced.

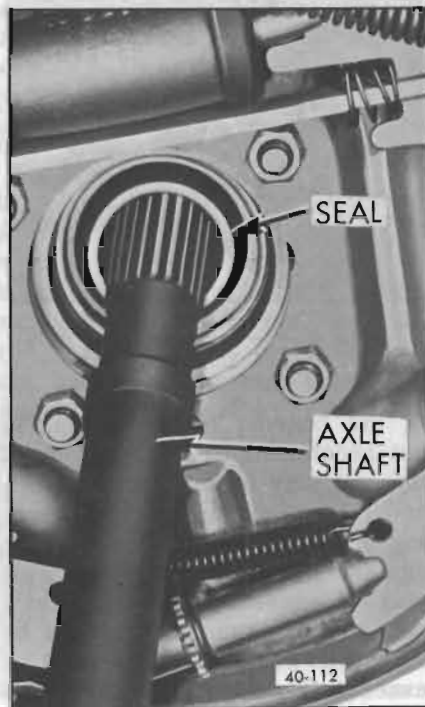

Figure 40-99—Removing Axle Shaft Seal

d. Remove and Install Axle Shaft Seal

1. Insert axle shaft so that splined end is just through seal.

2. Using axle shaft as a lever push down on shaft until seal is pried from housing. Remover J-8119 or J-6199 can also be used. See Figure 40-99.

3. Apply sealer to O.D. of new seal.

4. Position seal over Installer J-21129 and drive seal straight into axle housing until fully seated. See Figure 40-110.

5. Pack cavity and seal lip with front wheel bearing grease before installing axle shaft.

e. Install Axle Shaft Assembly

Rear axle shafts are interchangeable between sides.

1. Apply a light coat of wheel bearing grease in wheel bearing recess of housing. Install new

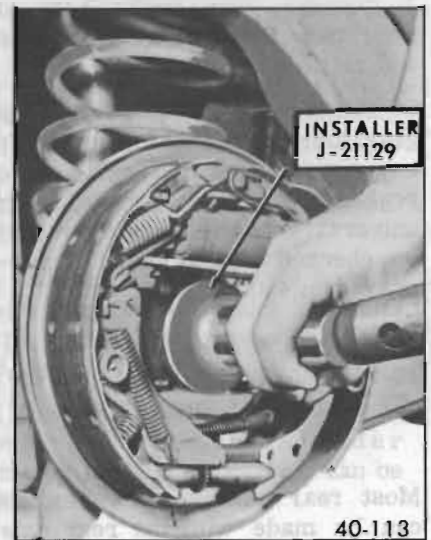

Figure 40-100—Installing Axle Shaft Seal

outer retainer plate gasket over retainer bolts.

2. Apply gear lubricant to the bearing surface and splines at the inner end of the axle shaft. Apply a coat of wheel bearing grease on the seal surface of the shaft to approximately 6 inches inboard of the shaft. Install axle shaft through seal carefully to avoid cutting seal lip. Drive shaft into position.

NOTE: If the axle to be installed is a positive traction axle, ONLY POSITIVE TRACTION LUBRICANT SHOULD BE USED.

3. Install retainer nuts and torque to 35 lb. ft.

4. Install drum and wheel. Torque lug nuts to 65 lb. ft.

40-25 REMOVAL AND DISASSEMBLY OF DIFFERENTIAL CASE ASSEMBLY

a. Removal of Differential Case Assembly—Differential in Car

1. Raise rear of car and support securely under rear of frame.

2. Loosen parking brake cables

so that brake is not applied when axle assembly is lowered.

3. Mark rear universal joint and pinion flange for proper alignment at reassembly. Disconnect rear universal joint by removing two U-bolts. Push rear propeller shaft forward as far as possible and wire it to the upper control arm frame bracket to support it out of the way.

4. Lower differential assembly just far enough to clear lower portion of fuel tank.

NOTE: The following steps also apply when making repairs with differential assembly removed from car.

5. Remove bolts securing cover to housing to drain lubricant.

6. While lubricant is draining, remove rear wheels and drums.

7. Remove rear axle shafts as described in paragraph 40-24.

NOTE: Before proceeding with following steps, it is advisable to check the existing ring gear to pinion backlash as described in paragraph 40-26, subparagraph f. This will indicate gear or bearing wear or an error in backlash or preload setting which will help in determining cause of axle noise. Backlash should be recorded so that if same gears are reused, they may be reinstalled at original lash to avoid changing gear tooth contact.

8. Mark side bearing caps for proper installation at reassembly.



Figure 40-101—Removing Differential Case Assembly

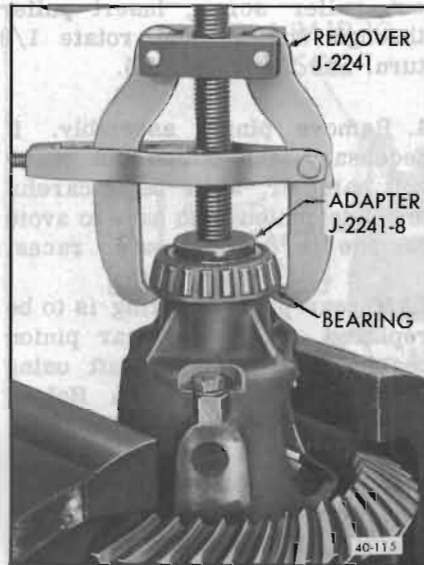

Figure 40-102—Removing Differential Side Bearings

Remove bolts holding differential side bearing caps to housing.

9. Remove two ring gear retaining bolts from differential case and install Ring Gear and Case Remover J-21322 with slide hammer as shown in Figure 40-101. Remove case assembly and place right and left bearing outer races and shims in sets with marked bearing caps so that they can be reinstalled in their original positions.

CAUTION: Do not allow case assembly to drop as this may cause injury or damage parts.

b. Disassemble Differential Case Assembly

1. If differential side bearings are to be replaced, insert Remover Adapter J-2241-8 in center hole and pull bearing using Puller J-2241 or Hydraulic Puller J-9005. See Figure 40-102.

2. Remove bolt that retains differential pinion axle. See Figure 40-103. Remove differential pinions, side gears and thrust washers from case.

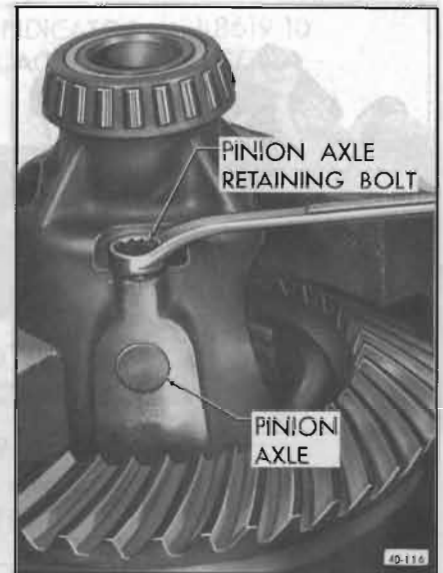

Figure 40-103—Removing Pinion Axle Retaining Bolt

3. If ring gear is to be replaced and it is tight on case after removing bolts, tap it off using a soft hammer; do not pry between ring gear and case.

c. Removal of Pinion and Bearings

1. Check pinion bearing preload as described in paragraph 40-26, subparagraph c.

If there is no preload reading, check for looseness of pinion assembly by shaking. Looseness indicates need for bearing replacement. If assembly is run

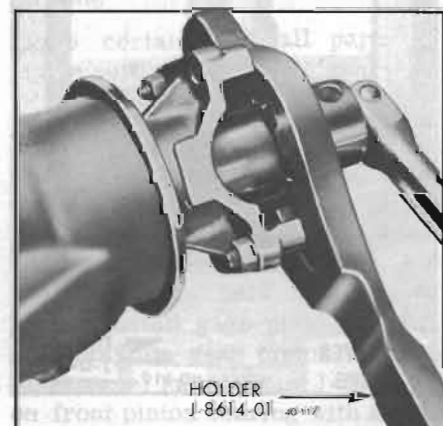

Figure 40-104—Removing Pinion Nut

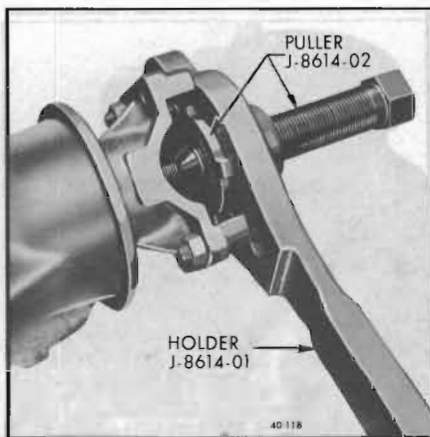

Figure 40-105—Removing Pinion Flange

long with very loose bearings, ring and pinion will also require replacement.

2. Install Holder J-8614-01 on pinion flange by using two 5/16-18 x 2" bolts with flat washers. Remove pinion nut and washer. See Figure 40-104.

3. Pull pinion flange from pinion using Puller J-8614-02 in Holder J-8614-01. To install puller, back

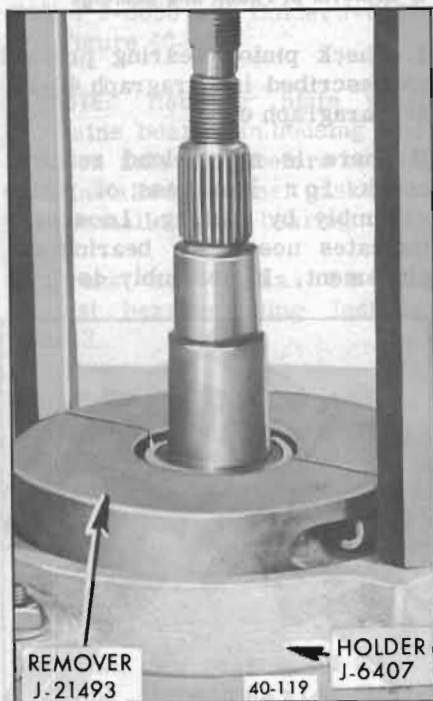

Figure 40-106—Removing Rear Pinion Bearing

out puller screw, insert puller through holder, and rotate 1/8 turn. See Figure 40-105.

4. Remove pinion assembly. If necessary, tap pinion out with soft hammer, while being careful to guide pinion with hand to avoid damage to bearing outer races.

5. If rear pinion bearing is to be replaced, remove rear pinion bearing from pinion shaft using Remover J-21493 with Holder J-6407. See Figure 40-106.

6. Pry pinion oil seal from carrier and remove front pinion bearing. If this bearing is to be replaced, drive outer race from carrier using a drift.

7. If rear pinion bearing is to be replaced, drive outer race from carrier using a drift in slots provided for this purpose.

40-26 ASSEMBLY AND INSTALLATION OF DIFFERENTIAL CASE ASSEMBLY

Before installation of any parts, examine the wearing surfaces of all parts for scoring or unusual wear. Make certain that the interior of the carrier housing is absolutely clean and dry. Also make certain that the parts to be assembled are absolutely clean and that there are no burred edges. Lubricate all parts with the specified rear axle lubricant just before assembly.

NOTE: If the Buick is equipped with a Positive Traction Differential, only Positive Traction Lube should be used.

NOTE: If the ring gear and pinion are changed, only factory hypoid lubricant should be used for filling because of its special anti-scoring properties. For this reason the proper lubricant is included in the carton with the replacement gears as received from the Buick warehouses.

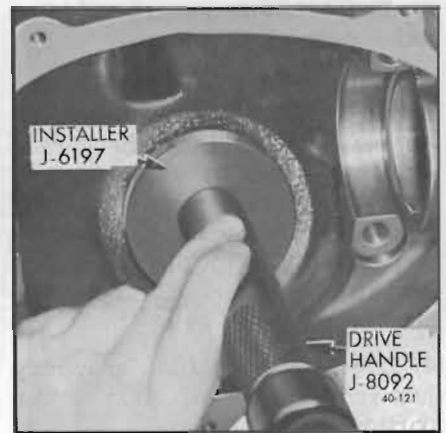

Figure 40-107—Installing Rear Pinion Bearing Outer Race

a. Install Pinion Bearing Outer Races in Carrier

1. If rear pinion bearing is to be replaced, install new outer race using Installer J-6197 with Driver Handle J-8092. See Figure 40-107.

2. If front pinion bearing is to be replaced, install new outer race using Installer J-7817 with Driver Handle J-8092. See Figure 40-108.

b. Set Pinion Depth

Ring and pinion gear sets are matched in a special test machine which permits adjustment of pinion depth in ring gear until a point



Figure 40-108—Installing Front Pinion Bearing Outer Race

is reached where best operation and proper tooth contact under load is obtained. At this point, the setting of the pinion with reference to the centerline of the ring gear is indicated by the machine. This setting may vary slightly from the design or "nominal" setting due to allowable variation in machining the parts. However, most production pinions and all pinions used for service replacement are zero or nominal pinions.

If during repair, a pinion is found having a plus or minus reading recorded in thousandths on the rear face of the pinion, this indicates that the pinion during testing was found to have best tooth contact at a position varying from design or nominal depth.

In order to compensate for all of the allowable machining variables, a procedure of gaging the carrier and shimming the pinion

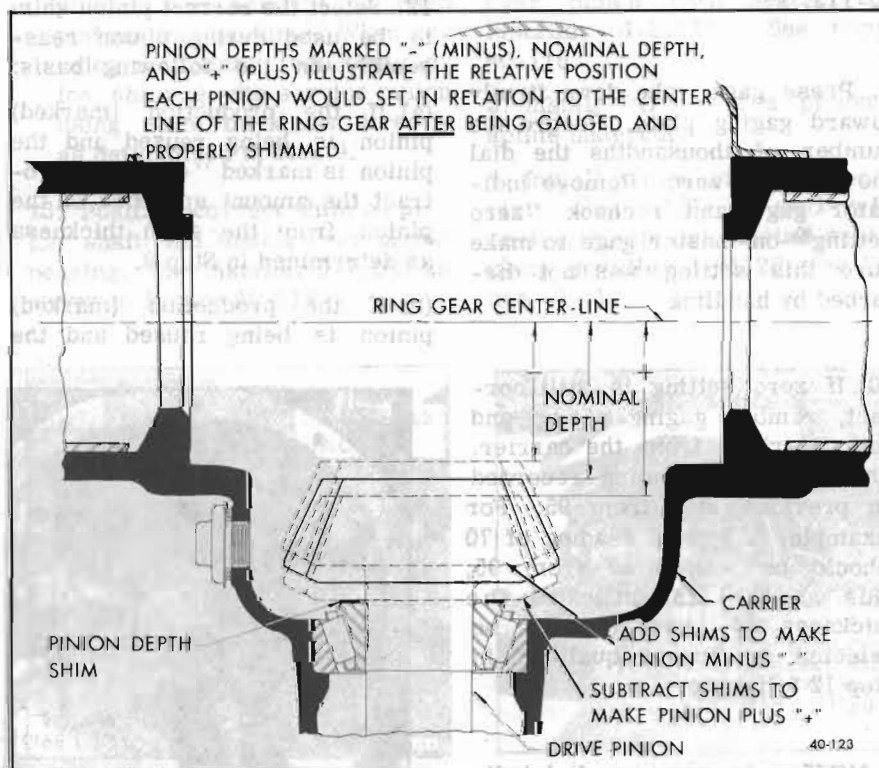

Figure 40-109—Nominal Pinion Setting Depth

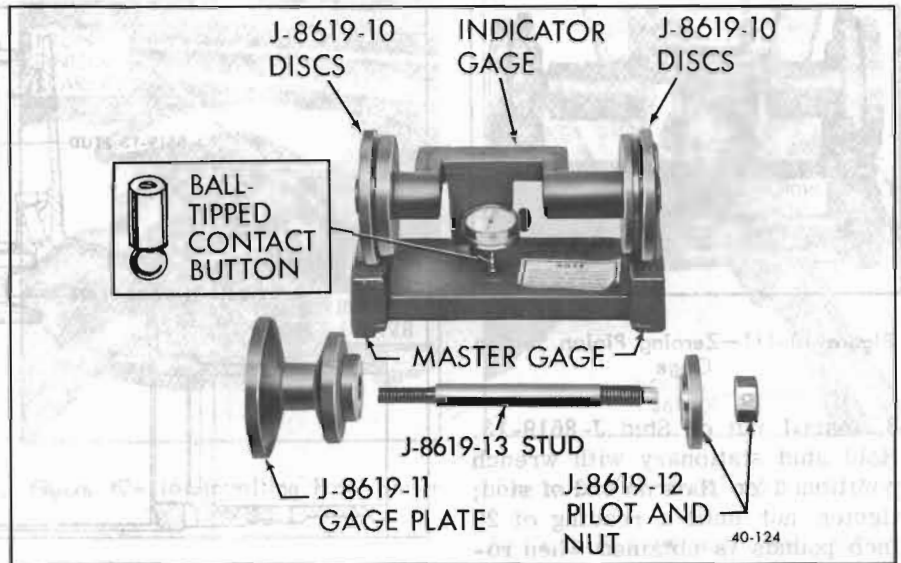

Figure 40-110—Pinion Setting Gage

has been developed. After gaging a carrier, the assembler is able to install a shim between the front face of the pinion and its bearing so that pinion depth can be adjusted to an exact required speci-

fication for best tooth contact in each axle assembly.

Pinion depth is set with Pinion Setting Gage J-8619 which consists of the following: (1) master gage, (1) indicator gage with dial indicator, (2) J-8619-10 Discs, (1) J-8619-11 Gage Plate, J-8619-12 Pilot and Nut with J-8619-13 Stud. See Figure 40-110. Although production pinions are marked, neither production nor service pinions have a gaging tooth. The pinion setting gage provides in effect a nominal or zero pinion as a reference.

Set up pinion setting gage as follows:

1. Be certain that all parts of pinion setting gage are clean.

2. Lubricate front and rear pinion bearings which will be used in final reassembly and position them in their respective races in the carrier. Thread Stud J-8619-13 into Gage Plate J-8619-11. With bearings held in place in races, install gage plate and stud assembly on rear pinion bearing inner race. Install Pilot J-8619-12 on front pinion bearing with small diameter on raised portion of bearing race. See Figure 40-112.

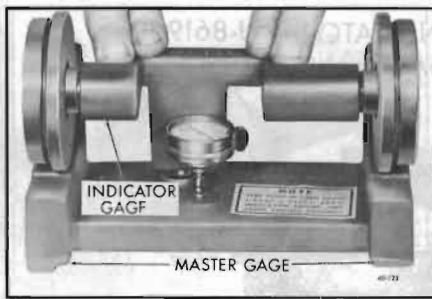

Figure 40-111—Zeroing Pinion Setting Gage

3. Install nut on Stud J-8619-13. Hold stud stationary with wrench positioned on flats on end of stud; tighten nut until a reading of 20 inch pounds is obtained when rotating gage plate assembly with an inch pound torque wrench.

4. Install the J-8619-10 Discs on the indicator gage. Install the small ball-tipped contact button on the stem of the dial indicator and mount the dial indicator on the indicator gage. See Figure 40-110.

5. Place the indicator gage on the master gage, as shown in Figure 40-111 so that its spring loaded center is engaged in the centering hole of the Master Gage.

6. Center the dial indicator contact button on the contact pad and lock the dial indicator by tightening the thumb screw.

7. Hold gage yoke down firmly, with large diameter portion of each disc contacting both the horizontal and vertical pads on master gage; set dial indicator at zero.

8. Be certain differential bearing support bores are free of dirt and burrs. Install indicator gage in carrier so that small diameter portion of discs rest in differ-

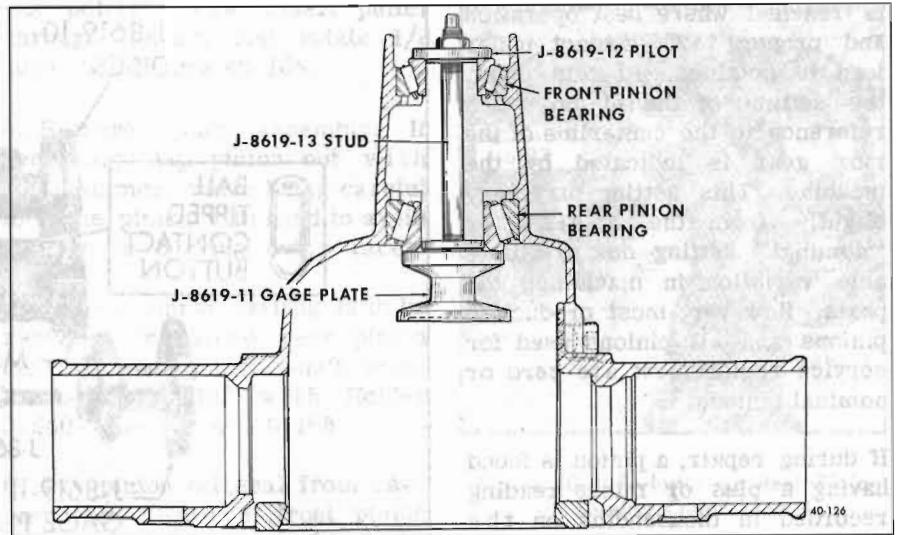

Figure 40-112—Pinion Gage Plate Installed in Carrier

ential bearing pedestal support bores. Spring-loaded center of gage must be located in centering hole of gage plate, and ball-tipped contact button of dial indicator must be positioned to bear against outer edge of gage plate top surface. See Figure 40-113.

9. Press gage yoke down firmly toward gaging plate. Record the number of thousandths the dial moves from zero. Remove indicator gage and recheck "zero setting" on master gage to make sure this setting was not disturbed by handling.

10. If zero setting is still correct, remove gaging set-up and both bearings from the carrier. Then subtract reading recorded in previous step from 95. For example, a typical reading of 70 should be subtracted from 95; this answer (25) indicates the thickness of the shims to be selected as further qualified in Step 12 following.

NOTE: An average dial indicator reading will range from .060" to .070" with a corre-

sponding shim thickness range of .035" to .025".

11. Examine the ring gear for nicks, burrs or scoring. Any of these conditions will require replacement of the gear set.

12. Select the correct pinion shim to be used during pinion reassembly on the following basis:

(a) If the production (marked) pinion is being reused and the pinion is marked "+" (plus), subtract the amount specified on the pinion from the shim thickness as determined in Step 9.

(b) If the production (marked) pinion is being reused and the

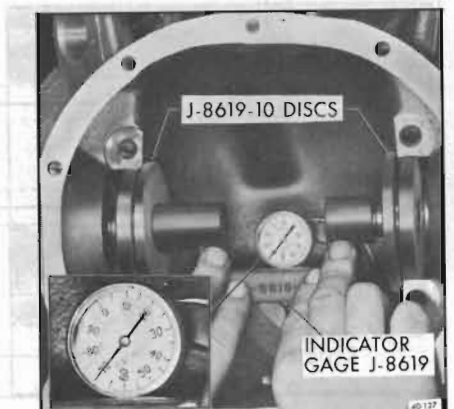

Figure 40-113—Checking Pinion Depth

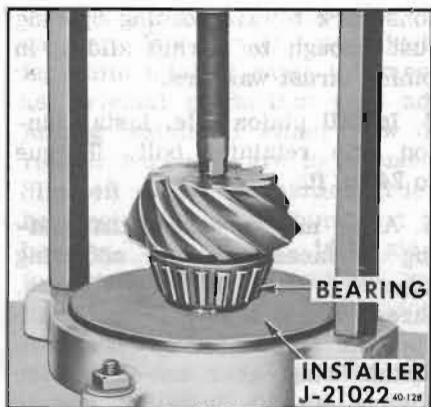

Figure 40-114—Installing Rear Pinion Bearing

pinion is marked “-” (minus), add the amount specified on the pinion to the shim thickness as determined in Step 9.

(c) If a service pinion is being used (no marking), shim pinion using shim thickness directly as determined in Step 9.

NOTE: Frequently production pinions are nominal or zero pinions (no marking). When re-using a nominal production pinion, shim as with service pinion using shim thickness directly as determined in Step 9.

13. Position correct shim on pinion shaft and install rear pinion bearing. Use Installer J-21022 as shown in Figure 40-114.



Figure 40-115—Installing Collapsible Spacer

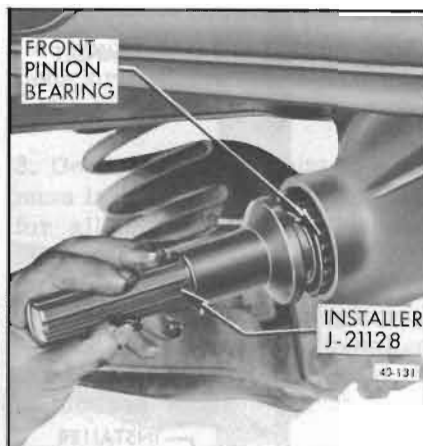

Figure 40-116—Installing Front Pinion Bearing

c. Install Pinion Assembly and Adjust Pinion Preload

1. Position pinion assembly in carrier and install collapsible spacer as shown in Figure 40-115.

2. Place front pinion bearing in position on pinion. Hold pinion fully forward and drive bearing over pinion until seated. Use Installer J-21128. See Figure 40-116.

3. Install “O” ring on pinion in spline undercut.

4. Install pinion oil seal in carrier. Coat O.D. of seal with sealing compound. Install seal by using Installer J-21128. See Figure 40-117.



Figure 40-117—Installing Pinion Oil Seal

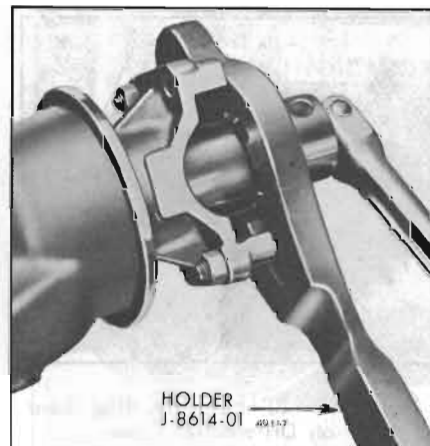

Figure 40-118—Installing Pinion Nut

5. Coat lips of pinion oil seal and seal surface of pinion flange with gear lube. Install pinion flange on pinion by tapping with a soft hammer until a few pinion threads project through flange.

6. Install pinion washer and nut. Hold companion flange with Holder J-8614-01. While intermittently rotating pinion to seat bearings, tighten pinion nut until end play begins to be taken up. See Figure 40-118.

NOTE: When no further end play is detectable, and when Holder J-8614 will no longer pivot freely as pinion is rotated preload specifications are being neared. Further tightening should be done only after preload has been checked.



Figure 40-119—Checking Preload

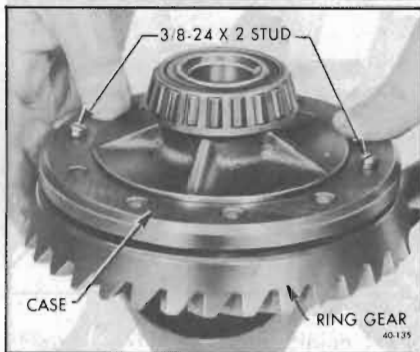

Figure 40-120—Installing Ring Gear on Differential Case

7. Check preload by using an inch pound torque wrench as shown in Figure 40-119.

NOTE: After preload has been checked, final tightening should be done very cautiously. For example, if when checking, preload was found to be 5 inch pounds, additional tightening of the pinion nut as little as 1/8 turn can add 5 additional inch pounds drag. Therefore, the pinion nut should be further tightened only a little at a time and preload should be checked after each slight amount of tightening. Exceeding preload specifications will compress the collapsible spacer too far and requires its replacement.

8. While observing the preceding caution, carefully set preload drag at 20 - 30 inch pounds on new bearings or 15 - 20 inch pounds on reused bearings.

9. Rotate pinion several times to assure that bearings have been seated. Check preload again. If drag has been reduced by rotating pinion, re-set preload to specification.

d. Assemble Differential Case Assembly

Before assembling the differential, examine the wearing surfaces of all parts for scoring or unusual wear. Also make certain that all parts are absolutely



Figure 40-121—Installing Differential Side Bearings

clean. Lubricate parts with rear axle lubricant just before assembly.

1. Place side gear thrust washers over side gear hubs and install side gears in case. If same parts are reused, replace in original sides.

2. Position one pinion (without washer) between side gears and rotate gears until pinion is directly opposite from loading opening in case. Place other pinion between side gears so that pinion axle holes are in line, then rotate gears to make sure holes in pinions will line up with holes in case.

3. If holes line up, rotate pin-

ions back toward loading opening just enough to permit sliding in pinion thrust washers.

4. Install pinion axle. Install pinion axle retaining bolt. Torque to 24 lb. ft.

5. After making certain that mating surfaces of case and ring gear are clean and free of burrs, thread two 3/8-24 x 2 studs into opposite sides of ring gear, then install ring gear on case. See Figure 40-120. Install ring gear attaching bolts just snug. Torque bolts alternately in progressive stages to 55 lb. ft.

6. If differential side bearings were removed, install new bearings using Installer J-9537 with Driver Handle J-8092. See Figure 40-121.

e. Install Differential Case and Adjust Side Bearing Preload

Differential side bearing preload is adjusted by changing the thickness of both the right and left shims by an equal amount. By changing the thickness of both shims equally, the original backlash will be maintained. All differential side bearing preload shims used in production are cast. Shims used during service repairs of the differential are of a stamped steel design and are used along with a production type, .140" thick, cast shim. Stamped steel service shims must be used when differential repairs are made that require changing side bearing preload. Service, steel, adjusting shims are available in thicknesses ranging from .040" to .082" in increments of .002".

1. Before installation of case assembly, make sure that side bearing surfaces in carrier are clean and free of burrs. Side bearings must be oiled with gear lube and if same bearings are being reused, they must have original outer races in place.

2. Place differential case and

bearing assembly in position in carrier. Use service type adjusting shim totaling same thickness as original production type adjusting shims if either new or reused bearings are to be used. Slip left shims in position at left bearing with steel shim next to bearing, then place .140" shim for right side in position and drive steel shim carefully into position between bearing and cast shim using a soft hammer. See Figure 40-122.

Install side bearing caps, as previously marked and tighten bolts to 53 lb. ft. before checking side bearing preload or backlash.

3. Rotate differential case assembly several complete turns to seat bearings. Check bearing preload using an inch pound torque wrench connected at pinion nut. Bearing preload should read 35-40 in. lbs. of rotating torque with new bearings or 20-25 in. lbs. of rotating torque with reused bearings. See Figure 40-119. If preload is not according to these specifications, increase shim thickness on each side .002" for each additional 10 in. lbs. preload desired, or decrease shim thickness .002" on each side for each 10 in. lbs. preload to be subtracted.

f. Adjust Differential Backlash

1. Rotate differential case several times to seat bearings, then mount dial indicator as shown in Figure 40-123. Use a small button on indicator stem so that contact can be made near heel end of tooth. Set dial indicator so that stem is as nearly as possible in line with gear rotation and perpendicular to tooth angle for accurate backlash reading.

2. With pinion locked to carrier, check gear lash at 3 or 4 points around ring gear. Lash must not vary over .001" around ring gear.

If variation is over .001" check for burrs, uneven bolting conditions or distorted case flange and make corrections as necessary.

3. Gear lash at the point of minimum lash should be .007" to .009" for all new gears. If adjustment is necessary, adjust to .008".

If original gear set having a wear pattern is being reinstalled, original gear lash should be maintained within $\pm .001$ ".

4. If gear backlash is not within specifications, correct by increasing thickness of one differential shim and decreasing thickness of other shim the same amount. In this way, correct differential bearing preload will be maintained.

Shift .002" in shim thickness for each .002" change in backlash desired. If backlash is .002" too much, decrease thickness of right shim .002" and increase thickness of left shim .002". If backlash is .002" too little, increase thickness of right shim .002" and decrease thickness of left shim .002".

5. Install new gasket in housing using heavy grease to retain it in place. Install cover. Torque cover bolts to 25-35 lb. ft. Wait 20 minutes and retorque cover bolts to specification.



Figure 40-122—Installing Differential Adjusting Shims



Figure 40-123—Checking Ring Gear to Pinion Backlash

g. Install Axle Shaft Assemblies

1. Apply a coat of wheel bearing grease in bearing recesses of housing. Install new outer retainer gaskets. Apply a thin coating of #2 Permatex or equivalent to outer diameter of seal if replaced. To help prevent damage to the lip of the wheel seal when installing axle shaft and to insure lubricant on the seal lip during the first few miles of operation, the axle shaft should be lightly lubricated with axle lubricant from the sealing surface to approximately 6 inches inboard of the shaft. Insert axle shaft assemblies carefully until shaft splines engage in differential to avoid damage to seals.

2. Drive axle shaft assemblies into position.

3. Place gasket and retainer over studs and install nuts. Torque nuts to 35 lb. ft.

4. Install brake drums over wheel bolts.

5. Install wheels and tighten wheel nut to 65 lb. ft.

h. Install Pinion Oil Seal with Differential Installed in Car

In case of pinion oil seal failure, remove old oil seal and install

new one (with differential remaining in car) as follows:

1. Mark propeller shaft and companion flange to permit proper alignment at reinstallation. Disconnect propeller shaft from companion flange and support shaft out of way. If U-joint bearings are not held by a retainer strap, use a piece of wire or tape to retain bearings in their journals.

2. Remove wheels and brake drums. Install an inch pound torque wrench on pinion nut, and record torque required to rotate pinion freely.

3. Mark position of companion flange, pinion shaft threads, and pinion nut so that they can be reinstalled in the same position.

4. Remove companion flange nut and washer using Holder J-6814-01 to hold flange.

5. Pry oil seal out of carrier.

6. Examine oil seal surface of companion flange for nicks or damaged surface. If damaged, replace flange.

7. Examine carrier bore and remove any burrs that might cause leaks around O.D. of seal.

8. Coat O.D. of new pinion oil seal with sealing compound and install seal using Installer J-21128.

9. Apply seal lubricant to O.D. of companion flange.

10. While holding companion flange with Holder J-8614-01, install companion flange nut and tighten to same position as marked in Step 3 above. Tighten nut 1/8 turn beyond alignment marks on pinion shaft threads in order to preload collapsible spacer. Check preload using an inch pound torque wrench; torque reading should be equal to or five inch pounds above that recorded in Step 2 preceding.

11. Connect propeller shaft to companion flange using alignment marks. Torque the four (4) nuts to 12 lb. ft.

DIVISION IV

TROUBLE DIAGNOSIS

40-27 PRE-REPAIR INVESTIGATION AND TROUBLE DIAGNOSIS

(PRE-REPAIR INVESTIGATION)

The pinion and ring gears must be completely assembled, installed and all preload and backlash adjustments completed prior to the start of this method of pinion depth setting. The following procedure can be used in place of the gage method of pinion depth setting.

A close examination of the differential prior to disassembly will often reveal valuable information as to the extent and type of repairs or adjustments necessary. The information thus gained, coupled with the report of malfunctioning will provide a basis for determining the degree of disassembly required. Since the frequent causes of axle noise are improper backlash, pinion bearing preload or side bearing preload, or a combination, a few simple adjustments may be all that is necessary to correct a problem.

Therefore, before removing the differential from the housing the following checks should be made with the results recorded and analyzed; (1.) Backlash, (2.) Total Assembly Preload, (3.) Red Lead Test.

Use care at all times to keep dirt and other foreign matter, such as grinder dust, soot or sand, away from differential to prevent possibility of subsequent failure.

a. Gear Tooth Nomenclature

The side of the ring gear tooth which curves outward, or is convex, is referred to as the "drive" side. The concave side is the "coast" side. The end of the tooth nearest center of ring gear is referred to as the "toe" end. The end of the tooth farthest away from center is the "heel" end. Toe end of tooth is smaller than heel end. It is very important that tooth contact be tested before the differential carrier assembly is disassembled. Variations in the carrier or pinion rear bearing may cause the pinion to be too far away from, or close to, the ring gear. Thus, the tooth contact must be tested and corrected if necessary, or the gears may be noisy.

b. Red Lead Test

1. Wipe oil out of carrier and carefully clean each tooth of ring gear.

2. Mix a small amount of powdered red lead (available from paint manufacturers and suppliers) with a few drops of rear axle lubricant (until the powder is just moist) and apply this mixture sparingly to all ring gear teeth using a medium stiff brush. When properly used, the area of pinion tooth contact will be visible when hand load is applied.

3. Tighten bearing cap bolts to 53 lb. ft.

4. Wedge a piece of hardwood or fiber block between the ring gear and differential housing to load the ring gear against the pinion or apply parking brake to load the ring gear against the pinion. Apply sufficient load so that 70-100 ft. lbs. of rotating torque is required to turn pinion. Turn the pinion with a wrench on the pinion nut to establish a tooth contact pattern in the red lead.

A test made without loading the gears will not give a satisfactory

pattern. Turn companion flange with wrench so that ring gear rotates one full revolution, then reverse rotation so that ring gear rotates one revolution in opposite direction. Excessive turning of ring gear may indicate good tooth pattern because one or two teeth are making proper contact.

5. Observe pattern on ring gear teeth and compare with Figures 40-124 and 125.

c. Effects of Increasing Load on Tooth Contact Pattern

When "load" on ring and pinion gear is increased, such as when car is accelerated forward from standstill or from normal drive, the tooth contact will tend to spread out, and under very heavy load will extend from near toe to near heel on the drive side. The entire contact also tends to shift toward heel under increasingly heavier loads and will become somewhat broader with respect to tops and bottoms of teeth. The patterns obtained by red lead tests, dependent upon degree of "loading", approximate a normal light load. For this reason, they will extend only about halfway.

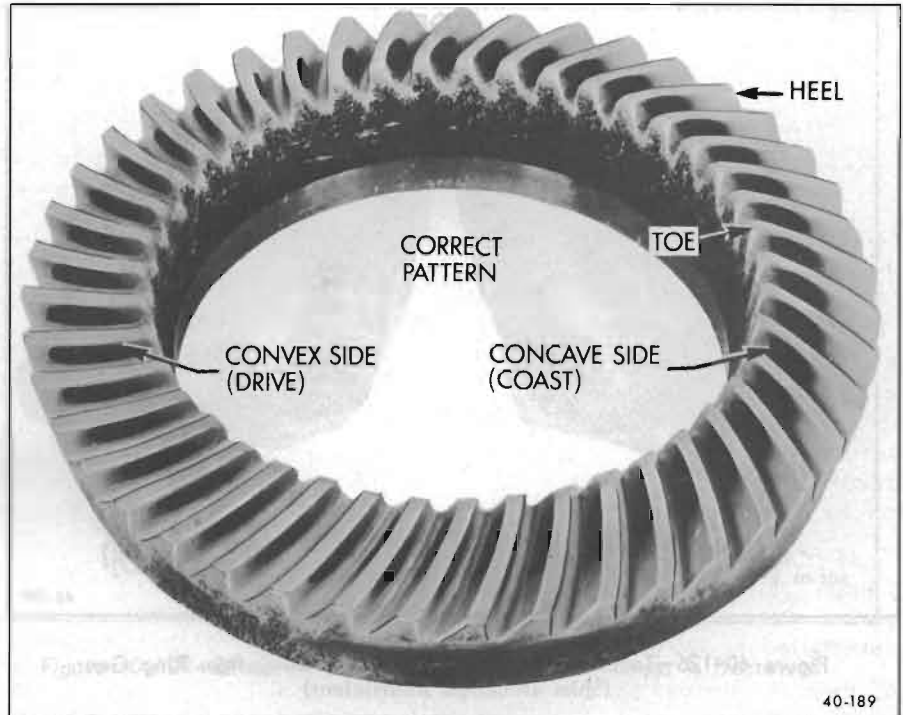

Figure 40-125—Desired Tooth Contact Under Light Load

The important thing to note is that the contact pattern is centrally located up and down on the face of the ring gear teeth.

d. Adjustments Effecting Tooth Contact

Two adjustments can be made

which will affect tooth contact pattern - backlash, and position of drive pinion in carrier. The effects of bearing preloads are not readily apparent on (hand loaded) red lead tests; however, these adjustments should be within specifications before proceeding with backlash and drive pinion adjustments.

Backlash is adjusted by means of the side bearing adjusting shims which moves the entire case and ring gear assembly closer to, or farther from, the drive pinion. (The adjusting shims are also used to set side bearing preload.)

The position of the drive pinion is adjusted by increasing or decreasing the shim thickness between the pinion head and inner race of rear bearing. The shim is used in the differential to compensate for manufacturing tolerances. Increasing shim thickness will move the pinion closer to centerline of the ring gear. Decreasing shim thickness will move the pinion farther away from centerline of the ring gear.

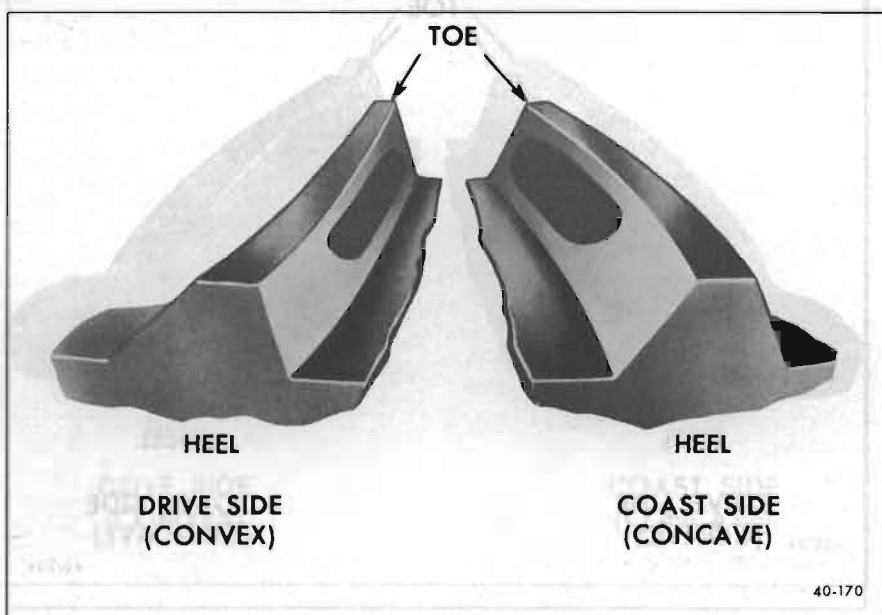

Figure 40-124—Gear Tooth Nomenclature

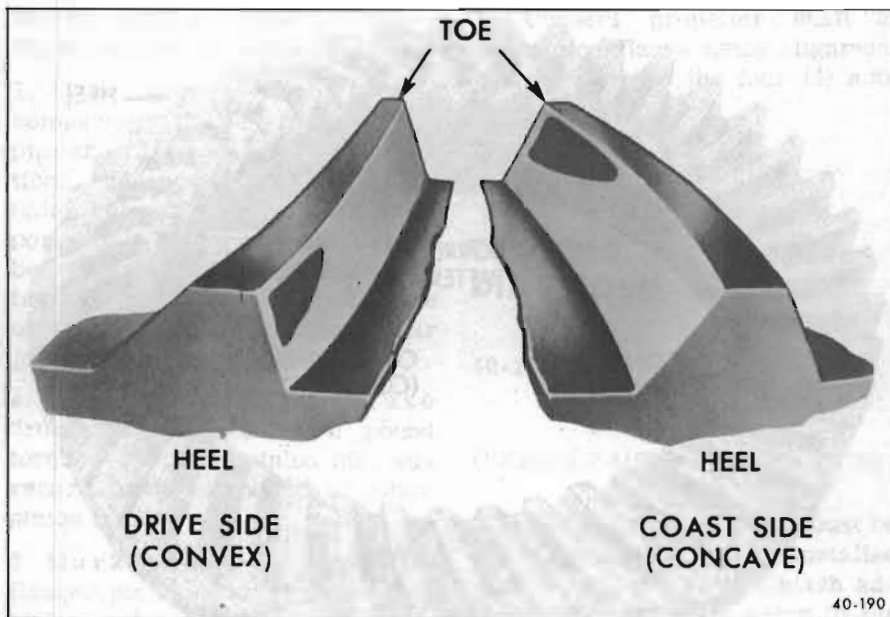

Figure 40-126—Tooth Pattern - Pinion too far away from Ring Gear (Shim Thickness Insufficient)

e. Effects of Pinion Position on Tooth Pattern

When the drive pinion is too far away from centerline of the ring gear, the pattern will be a high heel contact on drive side and high toe contact on coast side, provided backlash is within specifications of .007", .008", .009". See Figure 40-126. Moving the pinion closer to centerline of the ring gear by increasing shim thickness will cause the high heel contact on drive side to lower and move toward the toe; the high toe contact on coast side will lower and move toward the heel. See Figure 40-127.

When the pinion is too close to the centerline of the ring gear, the pattern will be a low toe contact on drive side, and a low heel contact on coast, provided backlash is within specifications. See Figure 40-128. Moving the pinion farther away from the ring gear by decreasing shim thickness will cause low toe contact on drive side to raise and move toward the heel; the low heel contact on coast side will raise and move toward the toe. See Figure 40-129.

NOTE: Whenever the rear axle is overhauled to the point of requiring a new ring gear and pinion set, the rear axle should be filled **ONLY** with the lubricant included with the gear set. Whenever the rear axle is overhauled to the point of requiring only pinion and/or side

bearings, it is recommended that lubricant 5.535 - 1050081 be used as refill for positive traction units or 5.535 - 1388901 for regular units.

(TROUBLE DIAGNOSIS)

a. Elimination of External Noises

When a rear axle is suspected of being noisy it is advisable to make a thorough test to determine whether the noise originates in the tires, road surface, front wheel bearings, engine, transmission, or rear axle assembly. Noise which originates in other places cannot be corrected by adjustment or replacement of parts in the rear axle assembly.

(1) **Road Noise.** Some road surfaces, such as brick or rough surfaced concrete, cause noise which may be mistaken for tire or rear axle noise. Driving on a different type of road, such as smooth asphalt or dirt, will quickly show whether the road surface is the cause of noise. Road noise usually is the same on drive or coast.

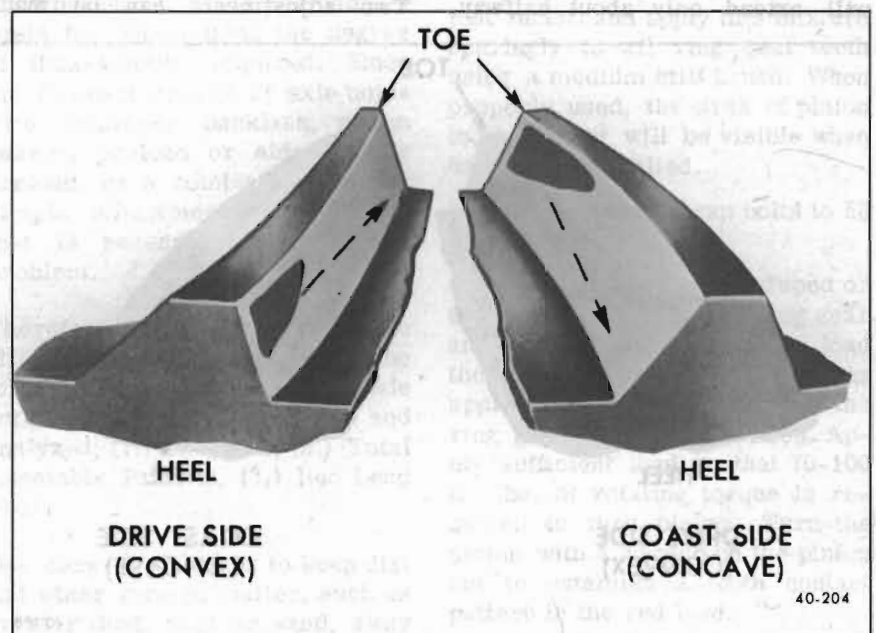

Figure 40-127—Effect on Pattern as Shim Thickness is Increased

(2) Tire Noise. Tire noise may easily be mistaken for rear axle noise even though the noisy tires may be located on the front wheels. Tires worn unevenly or having surfaces of non-skid divisions worn in saw-tooth fashion are usually noisy, and may produce vibrations which seem to originate elsewhere in the vehicle. This is particularly true with low tire pressure. Some designs of non-skid treads may be more noisy than others, even when tires are new.

(3) Test for Tire Noise. Tire noise changes with different road surfaces, but rear axle noise does not. Temporarily inflating all tires to approximately 50 pounds pressure, for test purposes only, will materially alter noise caused by tires, but will not affect noise caused by rear axle. Rear axle noise usually ceases when coasting at speeds under 30 miles per hour; however, tire noise continues but with lower tone as car speed is reduced. Rear axle noise usually changes when comparing "pull"

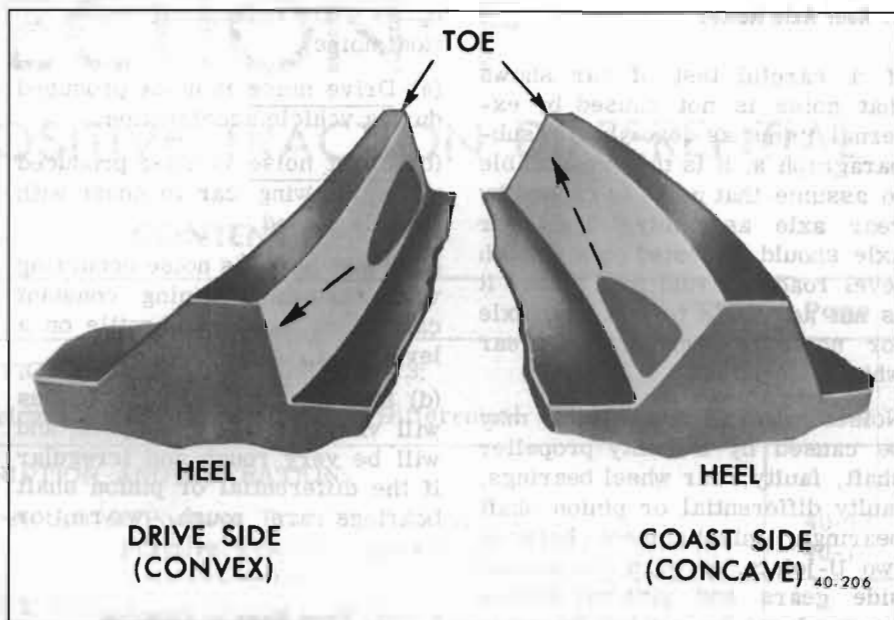

Figure 40-129—Effect on Tooth Pattern as Shim Thickness is Decreased

and "coast," but tire noise remains about the same.

(4) Front Wheel Bearing Noise. Loose or rough front wheel bearings will cause noise which may be confused with rear axle noises; however, front wheel bearing noise does not change

when comparing "pull" and "coast". Light application of brake while holding car speed steadily will often cause wheel bearing noise to diminish as this takes some weight off the bearing. Front wheel bearings may be easily checked for noise by jacking up the wheels and spinning them, also by shaking wheels to determine if bearings are loose.

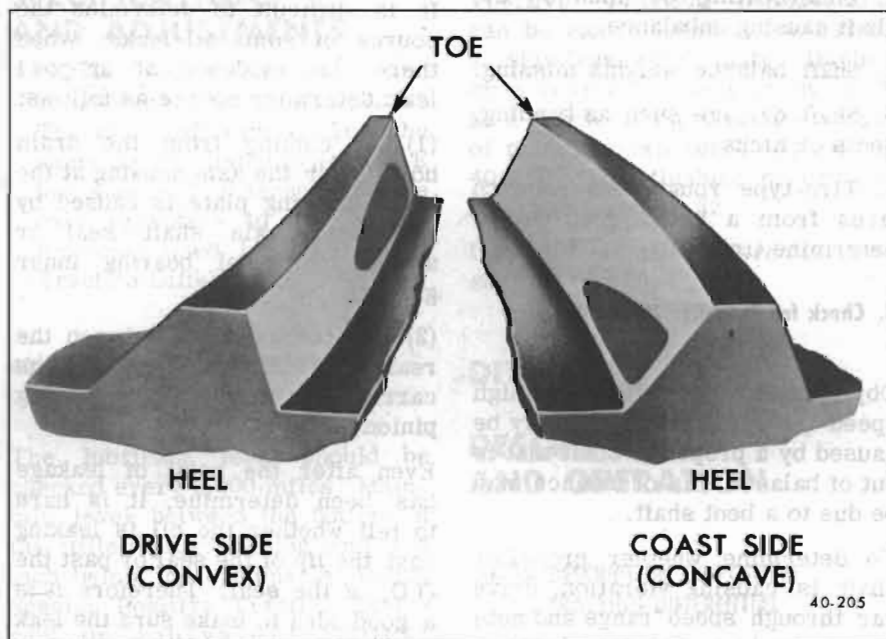

Figure 40-128—Tooth Pattern - Pinion too Close to Ring Gear (Shim Thickness Excessive)

(5) Engine and Transmission Noises. Sometimes a noise which seems to originate in the rear axle is actually caused by the engine or transmission. To determine which unit is actually causing the noise, observe approximate car speeds and conditions under which the noise is most pronounced; then stop car in a quiet place to avoid interfering noises. With transmission in neutral, run engine slowly up and down through engine speeds corresponding to car speed at which the noise was most pronounced. If a similar noise is produced with car standing, it is caused by the engine or transmission, and not the rear axle.

b. Rear Axle Noises

If a careful test of car shows that noise is not caused by external items as described in subparagraph a, it is then reasonable to assume that noise is caused by rear axle assembly. The rear axle should be tested on a smooth level road to avoid road noise. It is not advisable to test rear axle for noise by running with rear wheels jacked up.

Noises in rear axle assembly may be caused by a faulty propeller shaft, faulty rear wheel bearings, faulty differential or pinion shaft bearings, misalignment between two U-joints, or worn differential side gears and pinions; noises may also be caused by mismatched, improperly adjusted, or scored ring and pinion gear set.

(1) Rear Wheel Bearing Noise. A rough rear wheel bearing produces a vibration or growl which continues with car coasting and transmission in neutral. A brinelled rear wheel bearing causes a knock or click approximately every two revolutions of rear wheel, since the bearing rollers do not travel at the same speed as the rear axle and wheel. With rear wheels jacked up, spin rear wheels by hand while listening at hubs for evidence of rough or brinelled wheel bearing.

(2) Differential Side Gear and Pinion Noise. Differential side gears and pinions seldom cause noise since their movement is relatively slight on straight ahead driving. Noise produced by these gears will be most pronounced on turns.

(3) Pinion Bearing Noise. Rough or brinelled pinion bearings produce a continuous low pitch whirring or scraping noise starting at relatively low speed.

(4) Ring and Pinion Gear Noise. Noise produced by the ring and pinion gear set generally shows

up as drive noise, coast noise, or float noise.

(a) Drive noise is noise produced during vehicle acceleration.

(b) Coast noise is noise produced while allowing car to coast with throttle closed.

(c) Float noise is noise occurring while just maintaining constant car speed at light throttle on a level road.

(d) Drive, coast and float noises will vary in tone with speed, and will be very rough and irregular if the differential or pinion shaft bearings are rough, worn, or loose.

c. Body Boom Noise or Vibration

Objectional "body boom" noise or vibration at 55-65 MPH can be caused by an unbalanced propeller shaft. Excessive looseness at the spline can contribute to this unbalance.

Other items that may also contribute to the noise problem are as follows:

1. Undercoating or mud on the shaft causing unbalance.
2. Shaft balance weights missing.
3. Shaft damage such as bending, dents or nicks.
4. Tire-type roughness. Switch tires from a known good car to determine tire fault.

d. Check for Propeller Shaft Vibration

Objectionable vibrations at high speed (65 MPH or higher) may be caused by a propeller shaft that is out of balance. Out of balance may be due to a bent shaft.

To determine whether propeller shaft is causing vibration, drive car through speed range and note speed at which vibration is most pronounced. Shift transmission into lower gear range and drive

car at same engine speed as when vibration was most pronounced in direct drive. Note effect on vibration.

To determine engine speed, divide vehicle speed by the following transmission gear ratios as listed below:

EXAMPLE: If vibration is most pronounced in direct drive at 65 MPH, the same engine speed would be produced in second gear (V-6, three speed manual) at $65/1.68 = 39$ MPH; in low range (S.T. 300) at $65/1.76 = 37$ MPH; in low range (S.T. 400) at $65/1.50 = 43$ MPH.

If the vibration is still present at the same engine speed whether in direct drive or in the lower gear, since the propeller shaft speed varies, this cannot be the fault. If the vibration decreases or is eliminated in the lower gear, then the propeller shaft is out of balance and should be rebalanced. See Section C for balancing procedure and more complete trouble diagnosis.

e. Oil Leaks

It is difficult to determine the source of some oil leaks. When there is evidence of an oil leak determine source as follows:

(1) Oil coming from the drain hole under the axle housing at the brake backing plate is caused by a leaking axle shaft seal or a leaking wheel bearing inner gasket.

(2) Oil coming from between the rear pinion flange slinger and the carrier is caused by a leaking pinion seal.

Even after the point of leakage has been determined, it is hard to tell whether the oil is leaking past the lip of the seal or past the O.D. of the seal. Therefore it is a good idea to make sure the leak is stopped by using a nonhardening sealing compound around the O.D. of the new seal.