

SECTION A

ACCESSORIES ALL SERIES

CONTENTS

Division	Paragraph	Subject	Page
I		SPECIFICATIONS AND ADJUSTMENTS (Not Applicable)	
II		DESCRIPTION AND OPERATION (Not Applicable)	
III		SERVICE PROCEDURES:	
	150-1	Four Note Horn	150-3
	150-2	Rear Window Defroster	150-4
	150-3	Vacuum Trunk Release	150-7
	150-4	Vacuum Door Lock	150-8
	150-5	Tachometer	150-9
IV		TROUBLE DIAGNOSIS: (Not Applicable)	

DIVISION III

150-1 FOUR NOTE HORN

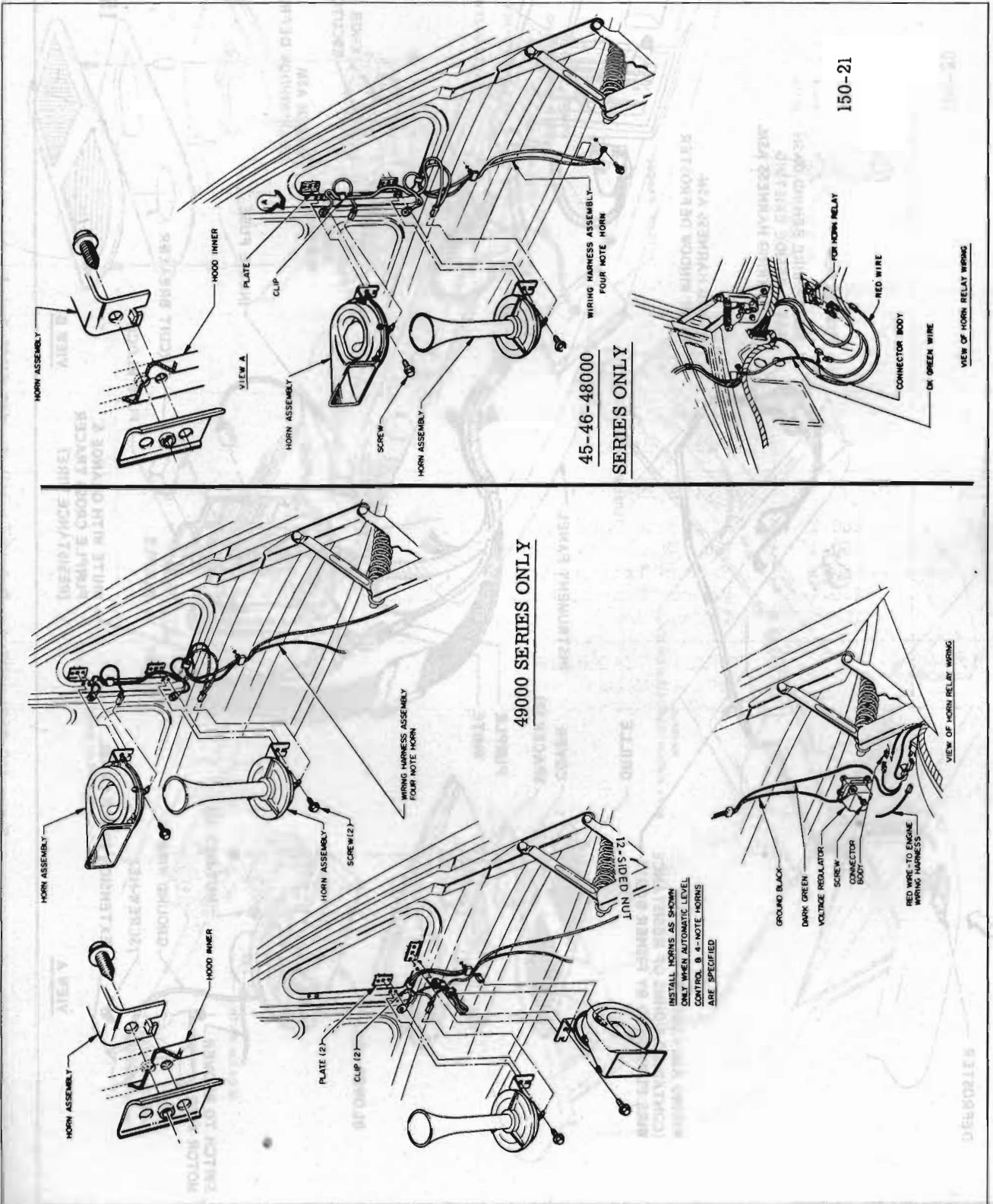

Figure 150-1—Four Note Horn Installation (45-46-48-49000 Series)

150-2 REAR WINDOW DEFROSTER

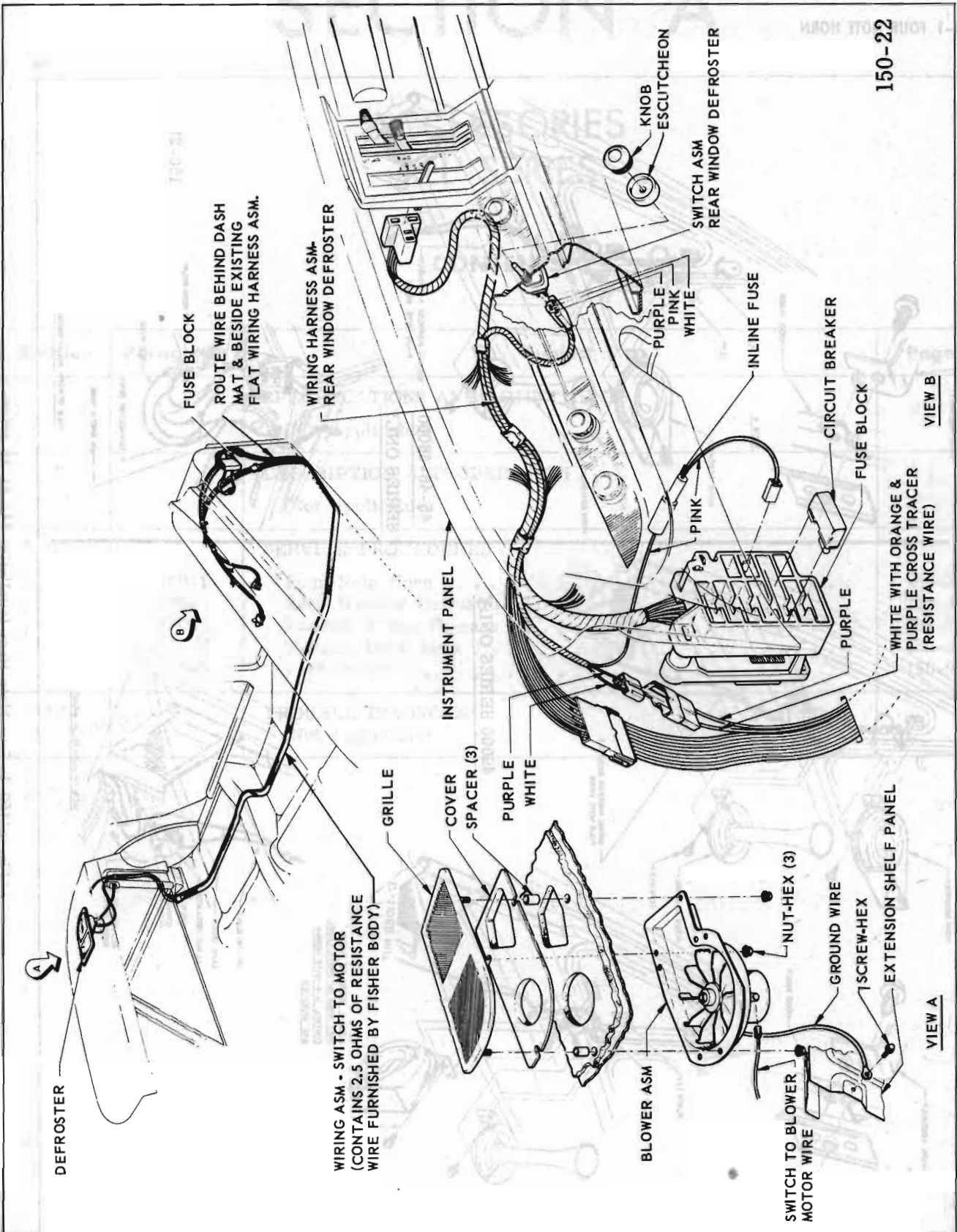

Figure 150-2—Rear Window Defroster Installation (43-44000 Series)

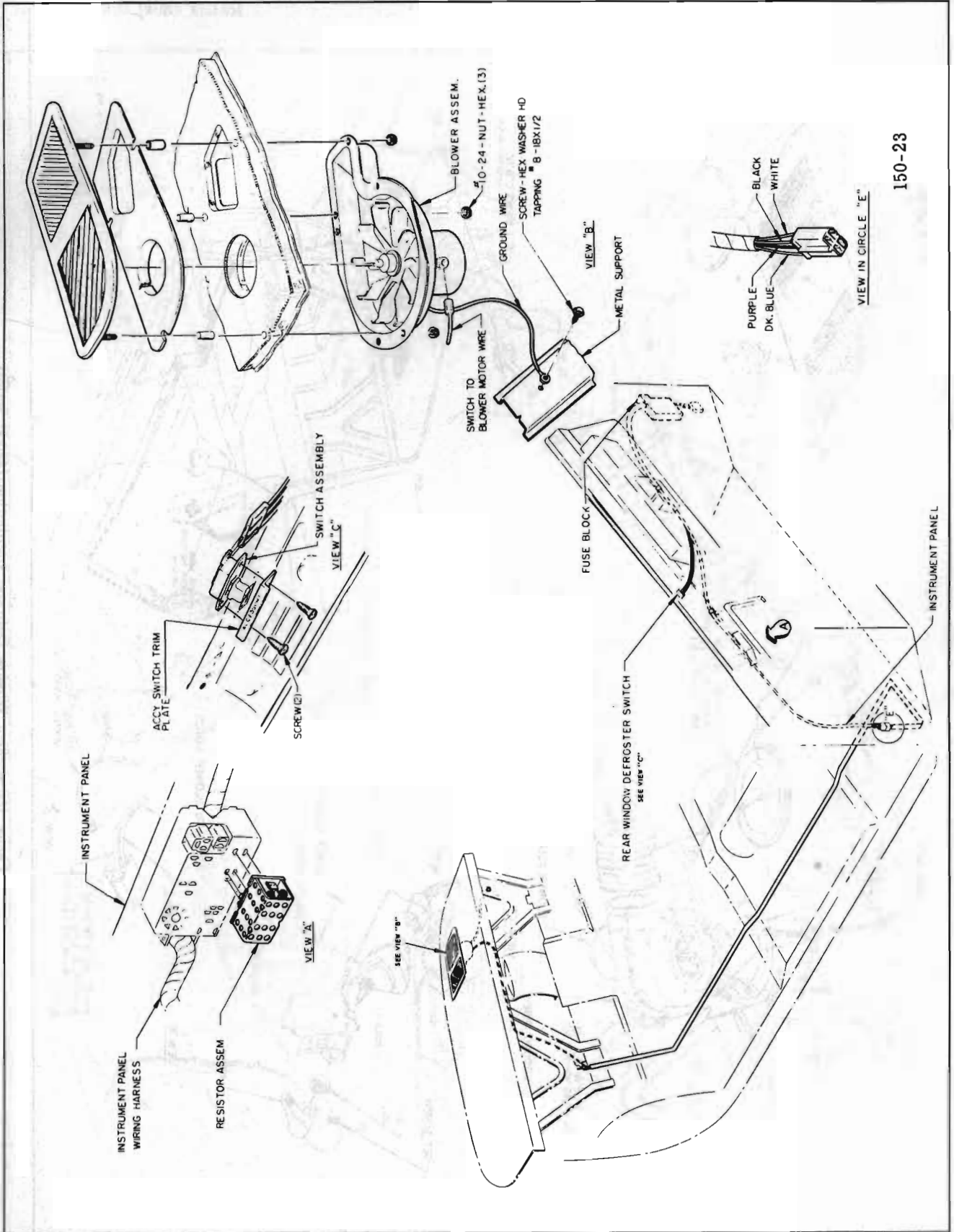

Figure 150-3—Rear Window Defroster Installation (45-46-48000 Series)

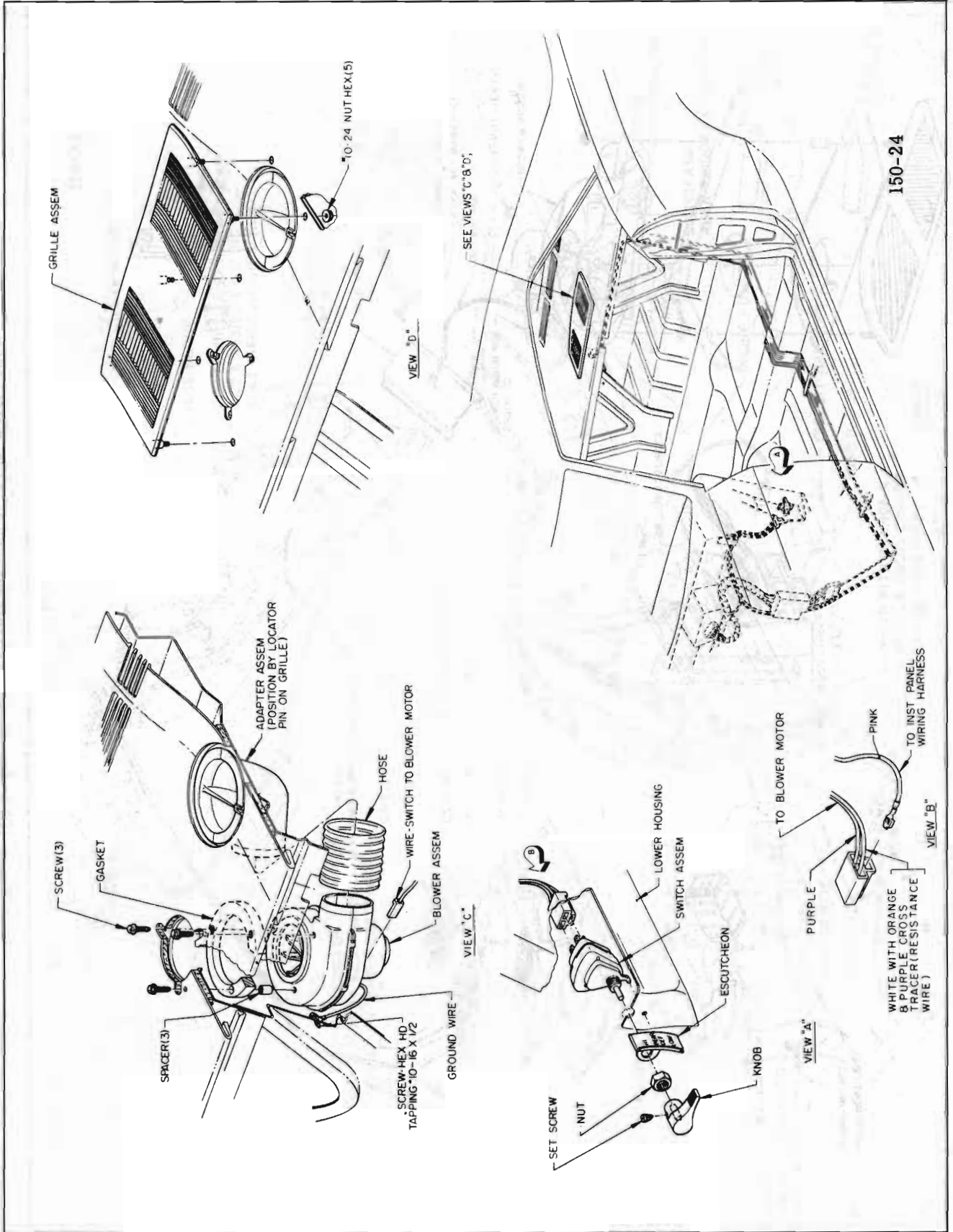

Figure 150-4—Rear Window Defroster Installation (49000 Series)

150-3 VACUUM TRUNK RELEASE

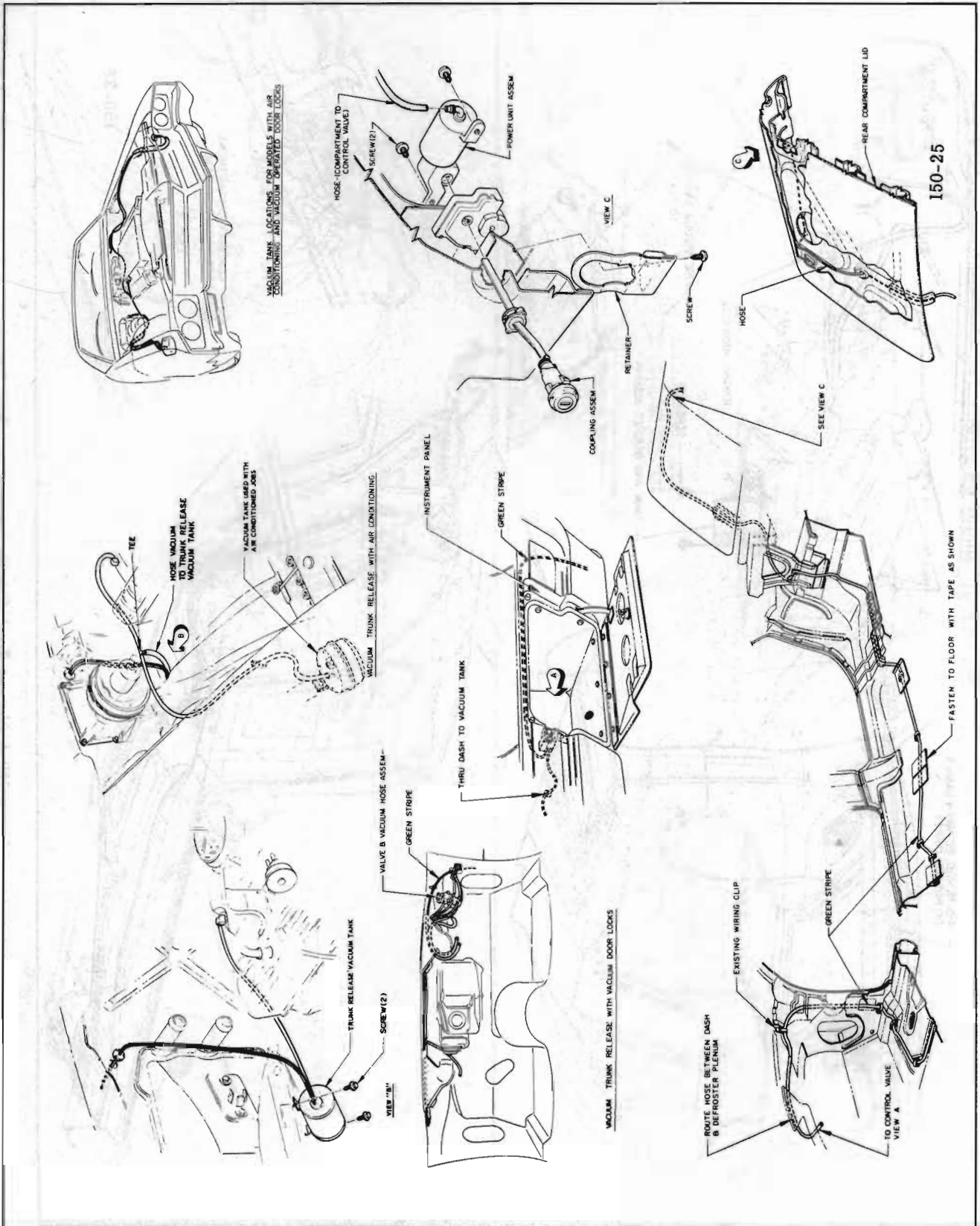

Figure 150-5—Vacuum Trunk Release Installation (45-46-48000 Series)

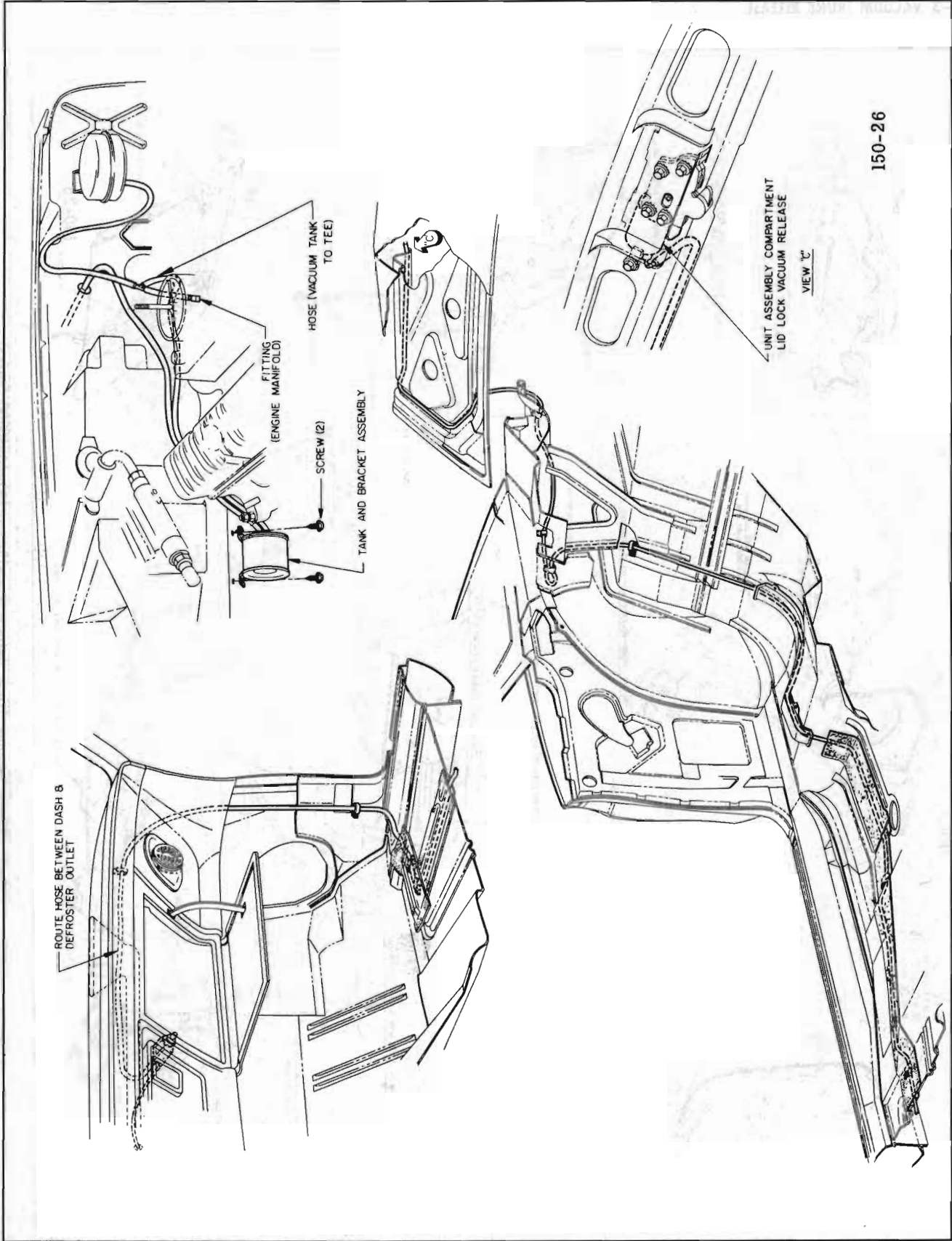

Figure 150-6—Vacuum Trunk Release Installation (49000 Series)

150-4 VACUUM DOOR LOCK

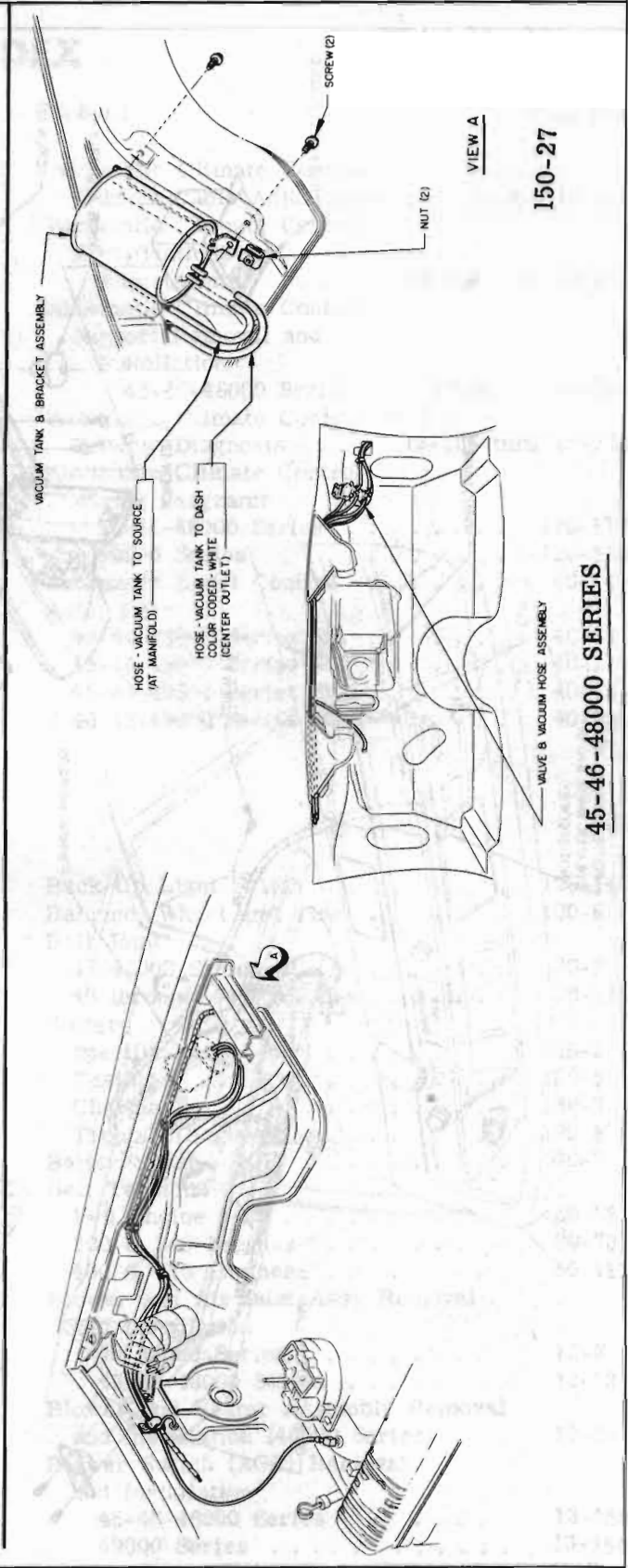
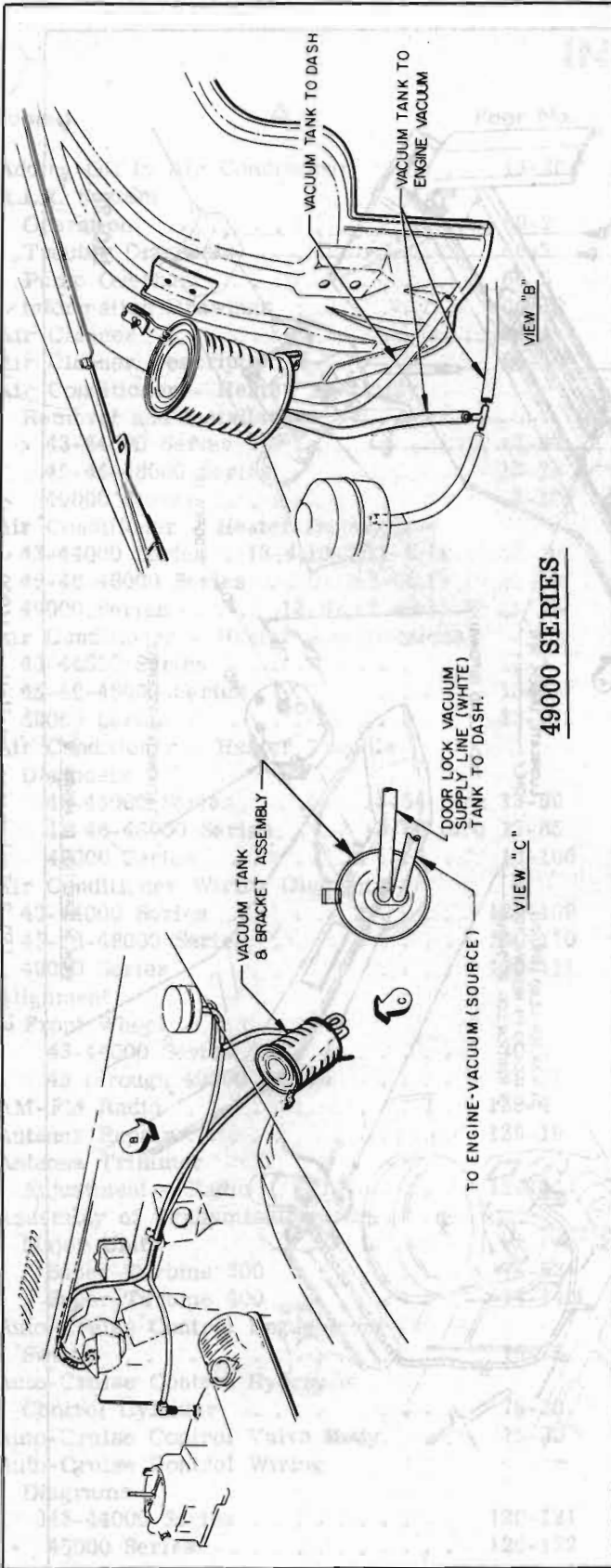

Figure 150-7—Vacuum Door Lock Installation (45-46-48-49000 Series)

150-5 TACHOMETER

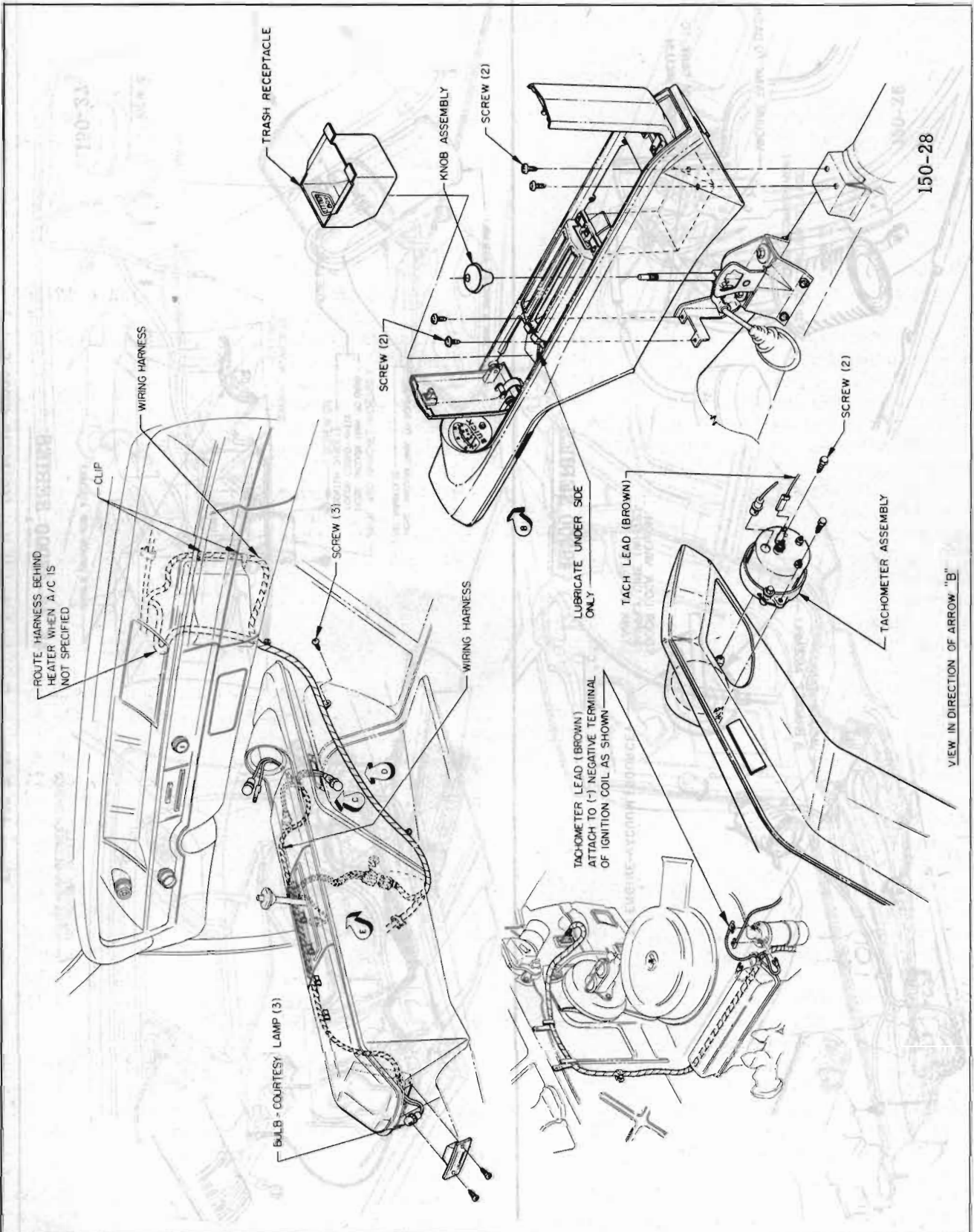

Figure 150-8—Tachometer Installation (46000 Series)