

SECTION B

HEATER—AIR CONDITIONER SYSTEM (45-46-48000 SERIES)

CONTENTS

Division	Paragraph	Subject	Page
I		SPECIFICATIONS AND ADJUSTMENTS:	
	13-38	Specifications	13-61
	13-39	Adjustment of Temperature and Defroster Control Cable	13-61
	13-40	Adjustment of Master Vacuum Switch	13-61
	13-41	Compressor Clutch Control Switch Adjustment	13-63
II		DESCRIPTION AND OPERATION:	
	13-42	General Description of System	13-63
	13-43	Description of Air Flow Thru System	13-63
	13-44	Operation of Controls	13-65
	13-45	Operation of Heater Portion of System	13-72
	13-46	Operation of Air Conditioner Portion of System	13-72
	13-47	Description of Air Conditioning Components	13-72
III		SERVICE PROCEDURES:	
		(Servicing Refrigerant Charged Components)	
	13-48	General Service Information and Safety Precautions	13-72
	13-49	Discharging System	13-73
	13-50	Adding Oil to System	13-73
	13-51	Flushing System	13-73
	13-52	Charging System	13-73
	13-53	Removal and Installation of Compressor	13-73
	13-54	Disassembly and Reassembly of Compressor	13-73
	13-55	Removal and Installation of Muffler	13-73
	13-56	Removal and Installation of Condenser	13-73
	13-57	Removal and Installation of Receiver-Dehydrator	13-73
	13-58	Removal and Installation of Expansion Valve	13-74
	13-59	Removal and Installation of Evaporator	13-74
	13-60	Removal and Installation of POA Valve	13-74
		(Servicing Air Distribution Components)	
	13-61	Removal and Installation of Plenum Blower and Air Inlet Assembly	13-74
13-62	Removal and Installation of Distribution Duct Assembly	13-78	
13-63	Removal and Installation of Air Conditioner-Heater Assembly	13-78	
13-64	Removal and Installation of Air Conditioner Control Assembly	13-79	
IV		TROUBLE DIAGNOSIS:	
	13-65	General Information	13-80
	13-66	Leak Testing System	13-81
	13-67	Functional Testing System	13-81
	13-68	Heater-Air Conditioner Vacuum and Electrical Circuits Test Sequence and Trouble Diagnosis Table	13-83
	13-69	Heater-Air Conditioner Refrigerant Circuit Trouble Diagnosis Chart	13-85

DIVISION I SPECIFICATIONS AND ADJUSTMENTS

13-38 SPECIFICATIONS

a. Tightening Specifications

Part	Location	Torque Lbs. Ft.
Nut	Drive Plate Nut to Compressor Shaft	14-16
Nut	Compressor Rear Head to Shell	19-23
Cap	Schrader Service Valve	4-5

Metal Tube Outside Diameter	Thread and Fitting Size	Steel Tubing Torque Lb.-Ft.	Aluminum or Copper Tubing Torque Lb.-Ft.	Nominal Torque Wrench Span
1/4	7/16	10-15	5-7	5/8
3/8	5/8	30-35	11-13	3/4
1/2	3/4	30-35	11-13	7/8
5/8	7/8	30-35	18-21	1 1/16
3/4	1 1/16	30-35	23-28	1 1/4

If a connection is made with steel to aluminum or copper, use torques for aluminum. In other words, use the lower torque specification.

Use steel torques only when both ends of connection are steel.

Figure 13-106—Pipe and Hose Connection Torque Chart

b. Compressor Specifications

Type	Six Cylinder Axial
Make	Frigidaire
Displacement - (cu. in.)	12.6
Oil	Frigidaire 525 Viscosity
Oil Content (New)	10-1/2 oz. Fluid
Air Gap Between Clutch Drive Plate and Pulley	.022" to .057"
Clutch Type	Magnetic
Belt Tension	100 lbs.

c. General Specifications

Type of Thermostat	180°
Capacity of Cooling System with Air Conditioner	(45000 Series) 14.7 Qts. (46-48000 Series) 18.2 Qts.
Refrigerant	Freon 12, Ucon 12, Genetron 12, Isotron 12
Refrigerant Capacity (Fully Charged)	4-1/4 lbs.

13-39 ADJUSTMENT OF TEMPERATURE AND DEFROSTER CONTROL CABLE

The instrument panel control assembly cables are adjusted by rotating the adjuster nuts which are a part of the control cable (see Figure 13-107). To adjust

either the temperature or the defroster control cable proceed as follows:

1. Remove center air conditioner outlet and pull out center duct.
2. Position WARMER and/or DEFROST levers fully to the left and

rotate adjuster nuts until levers have 1/8 to 3/16 inch spring back from full left position.

13-40 ADJUSTMENT OF MASTER VACUUM SWITCH

1. Place FAN lever in OFF position.

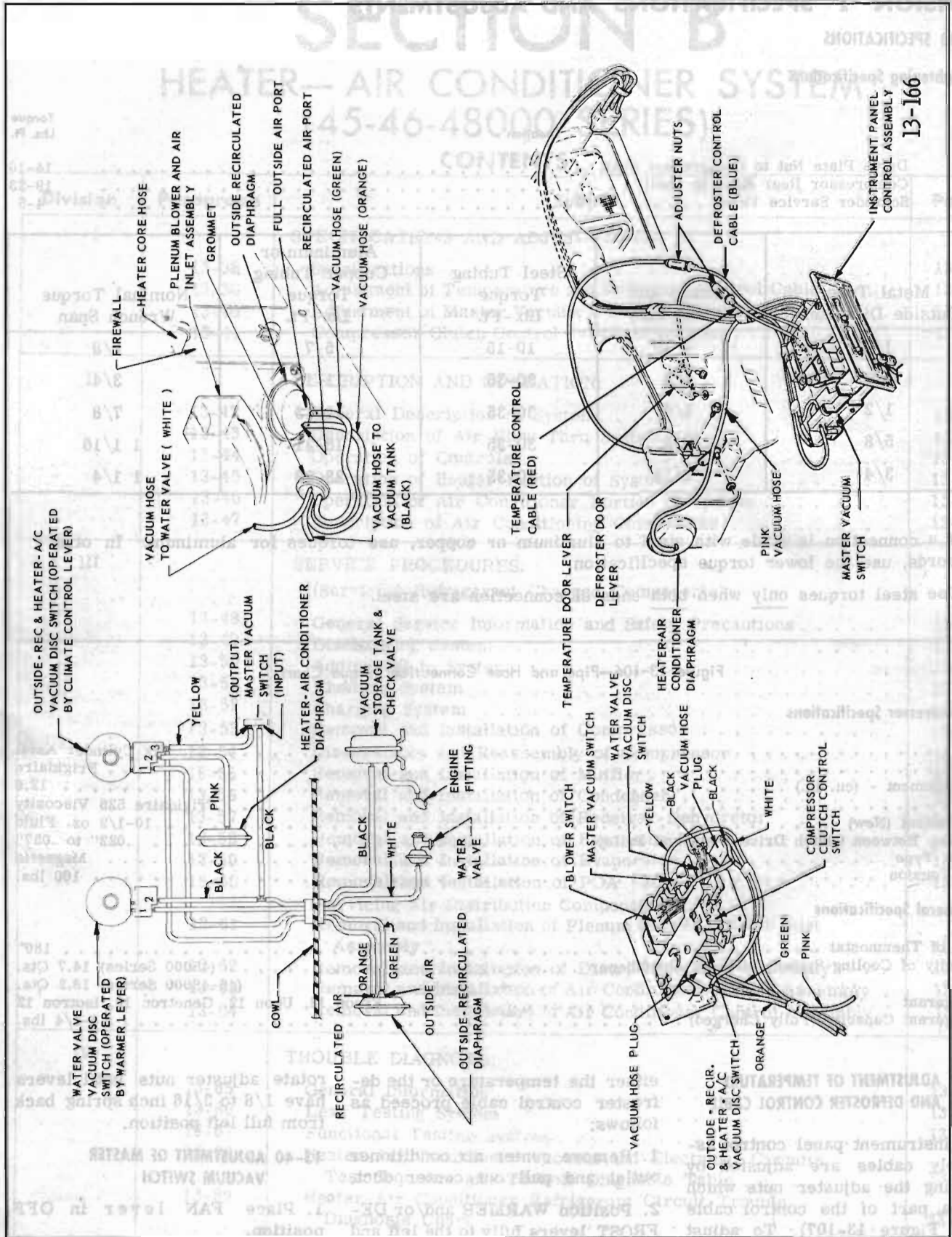

13-166

Figure 13-107—Air Conditioner Vacuum Hose and Control Cable Installation

2. Loosen master vacuum switch (see Figure 13-107) attaching screws and push switch against control lever on circuit control assembly to fully depress plunger.

3. Tighten mounting screws.

13-41 COMPRESSOR CLUTCH CONTROL SWITCH ADJUSTMENT

Loosen screws securing switch to control assembly. Place Climate Control lever in VENT position and push switch against cam of lever until it clicks open. Secure in position. Move lever back and forth between NORM and VENT and listen for and observe contact of clutch control switch opening. A clicking sound should be heard. Switch must be fully open by time lever is in VENT position.

DIVISION II DESCRIPTION AND OPERATION

13-42 GENERAL DESCRIPTION OF SYSTEM

The heater-air conditioner system is a series type unit in which the cooling unit and heating unit are so arranged that the air flows through both units. With an arrangement of this type it is possible to simultaneously control both the air conditioning and heating of the air in the car. Thus the air may be cooled, heated or both cooled and reheated.

The following description of the heater-air conditioner system is divided into five areas: (1) a description of route the air takes as it flows through the system under various modes of operation, (2) how the doors (which regulate the flow of air) operate and the sequence in which they operate, (3) the theory behind obtaining hot air from the system, (4) the theory of how the system cools the air, and (5) a description of the function and purpose of each

component in the air conditioning refrigeration circuit.

13-43 DESCRIPTION OF AIR FLOW THRU SYSTEM

The following description of the route the air takes as it flows thru the system under various modes of operation is divided into four parts; air flow under air conditioning mode of operation, air flow under heating mode, air flow during defrosting mode, and air flow during simultaneous air conditioning and reheating modes of operation.

a. Air Flow During Air Conditioning Mode of Operation

During normal mode of operation of the air conditioner, the FAN lever (see Figure 13-108) is set at any of the four stops away from the OFF position. The Climate Control lever will be set at NORM detent, and the WARMER and DEFROST levers are positioned fully to the left.

Under these conditions the air flows into the system thru the opening in the cowl. Moving of the FAN lever to one of the four detents away from the OFF position opens the main vacuum switch and applies vacuum to re-

circulated air port of the outside-recirculated diaphragm causing it to partially open. Placing of the climate control lever at NORM position applies vacuum to outside air port of outside-recirculated diaphragm. When vacuum is applied to both ports of the diaphragm the air door fully opens (see Figure 13-109).

Now the air flows from the cowl plenum chamber into the blower air inlet assembly. From here the air flows thru the adapter to the evaporator assembly. Because the WARMER lever is fully to the left, the temperature air door (see Figure 13-109) is closed preventing any air flow thru the heater core. Consequently the cooled air flows past the normally open heater-air conditioner air door and out to the air conditioner outlets. The above described air flow also applies to VENT mode of operation, the only difference being that the compressor does not operate.

During recirculate mode of operation the climate control lever is in RECIR position. The air flow is the same with the exception that no vacuum is applied to outside air ports of the outside-recirculated diaphragm. The effect of this is to cause the air door to only partially open (see

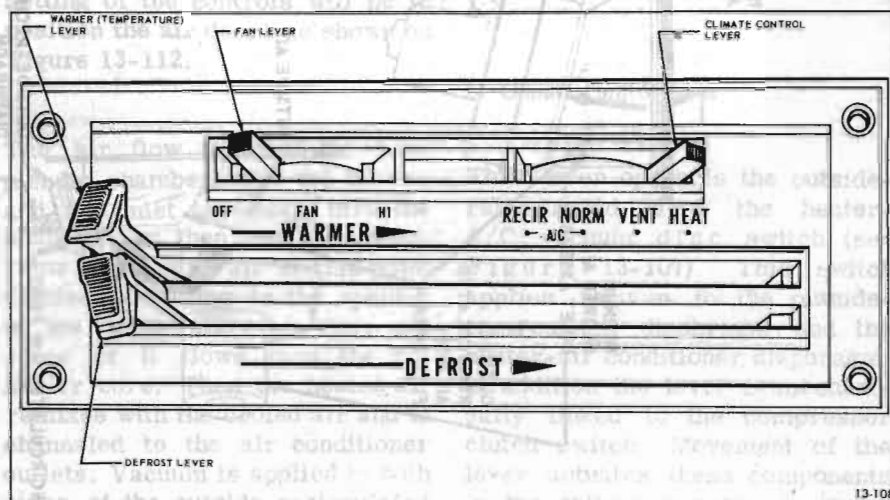

Figure 13-108—Instrument Panel Control Assembly

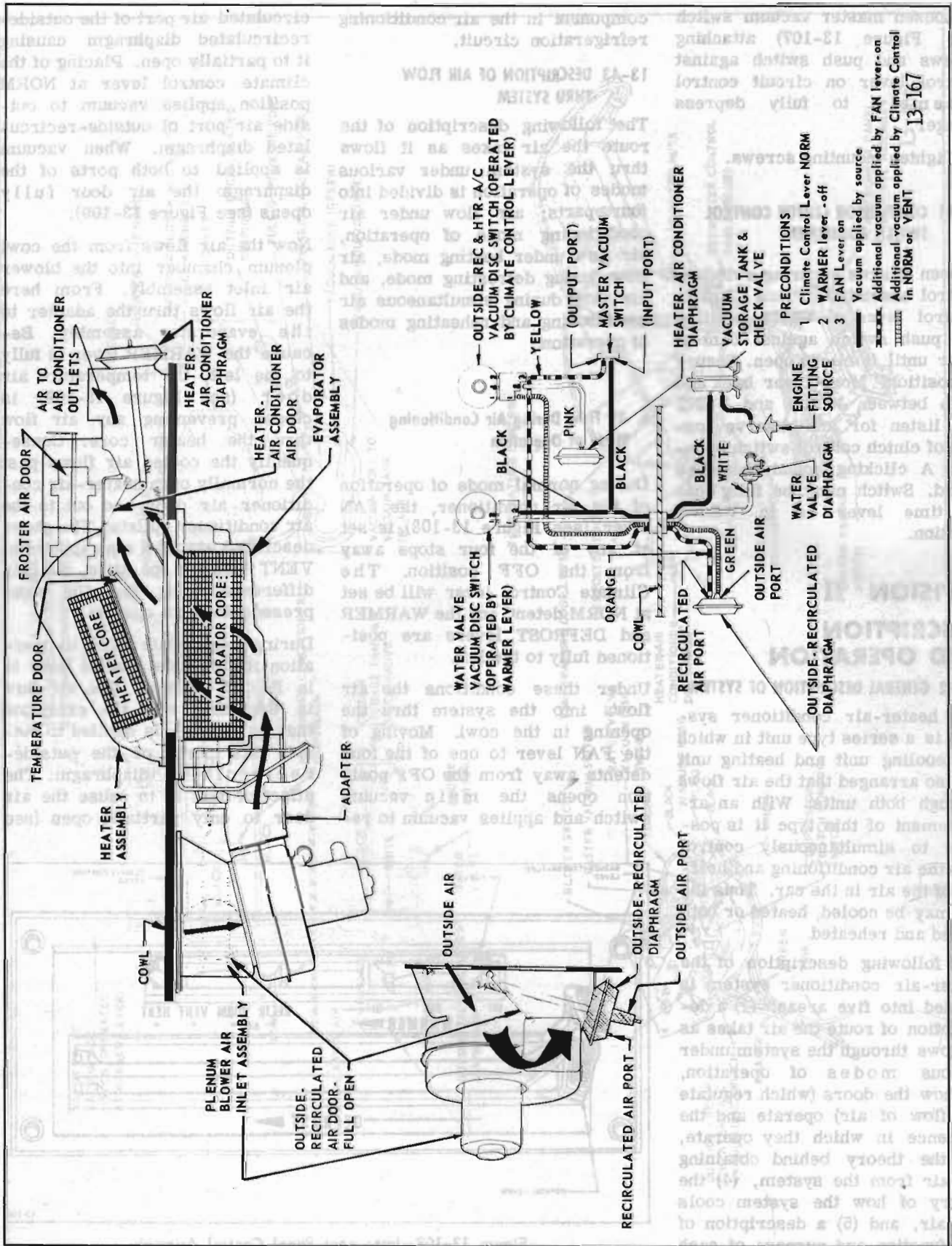

Figure 13-109—Air Flow During NORM or VENT Modes of Air-Conditioner Operation

Figure 13-110) thereby causing the system to draw some of its air supply from inside the car. This has an added cooling effect because the already cooled air from inside the car can now be recirculated and further cooled.

b. Air Flow During Heater Mode of Operation

For operation of the heater portion of the system the controls are set as follows: FAN lever in one of four detents away from OFF position, climate control lever in HTR position, WARMER lever position to the right as described, DEFROST lever positioned fully to the left. (See Figure 13-111). With the controls set as desired above, the air flow is similar to the flow for air conditioner operation. The FAN lever, being away from the OFF position, permits vacuum to flow to the Recirculated Air port of the Outside Recirculated diaphragm (see Figure 13-111) thereby causing the air door to partially open. The climate control lever being positioned at HEAT detent permits vacuum to flow to the outside air port of the outside-recirculated diaphragm thereby causing the air door open to its full extent. In addition vacuum is also applied to the heater-air conditioner diaphragm. The effect of this is that the diaphragm pulls its related air door closed (see Figure 13-111).

The outside air flows as before into the cowl plenum air chamber, down into the blower and air inlet assembly thru the adapter and evaporator core, and then into the heater assembly. At this point the air flow divides (according to the opening of the temperature door) and some of it flows thru the heater core and then remixes with the non-heated air (see Figure 13-111). The heater-air con-

ditioner air door being closed, blocks the air flow to the air conditioner outlets and thereby forces it out the heater outlets.

c. Air Flow For Defroster Mode of Operation

The air flow and position of the controls is very similar to the conditions of the system during heater mode of operation with the exception that the DEFROST lever is now positioned as required to the right. This has the effect of tilting the defroster air door to deflect some or all of the air to the defroster outlets. The position of the defroster air door is controlled by a control cable.

d. Air Flow For Both Air Conditioning and Heater Mode of Operation

When both the air conditioner and the heater are operated simultaneously to cool, dry and then reheat the air, the controls are set as follows: FAN lever in one of four detents away from OFF position, climate control lever in NORM, WARMER lever positioned as desired toward right, and DEFROST lever either off (left most position) or on (as required) toward right. The effect of this setting of the controls will be to position the air doors as shown on Figure 13-112.

The air flow is from the cowl plenum chamber, into the blower and air inlet assembly, thru the adapter, and then thru the evaporator core. The air at this point divides according to the opening of the temperature air door and some of it flows thru the hot heater core. Then the heated air remixes with the cooled air and is channeled to the air conditioner outlets. Vacuum is applied to both sides of the outside-recirculated diaphragm (see Figure 13-112) to

cause the air door to fully open permitting only outside (no recirculated) air into the system.

13-44 OPERATION OF CONTROLS

All the controls for regulation of the heater-air conditioner system are located on the instrument panel control assembly. They operate the system as follows:

a. Fan Lever

This lever operates the heater blower switch (see Figure 13-113). When this lever is moved from one extreme to the other, four stops will be felt. Moving from left to right, the 1st stop will provide low-low blower speed (refer to Figure 13-114). The second, third and fourth detents respectively provide low, medium and high blower speeds.

The FAN lever is mechanically linked to the master vacuum switch (see Figure 13-107). Whenever the FAN lever is away from OFF position vacuum is applied to recirculated air port of outside-recirculated diaphragm via this vacuum switch and the door is partially opened.

b. Climate Control Lever

This lever operates the outside-recirculated and the heater-A/C vacuum disc switch (see Figure 13-107). This switch applies vacuum to the outside-recirculated diaphragm and the heater-air conditioner diaphragm. In addition the lever is mechanically linked to the compressor clutch switch. Movement of the lever actuates these components in the following sequence (refer to Figure 13-114).

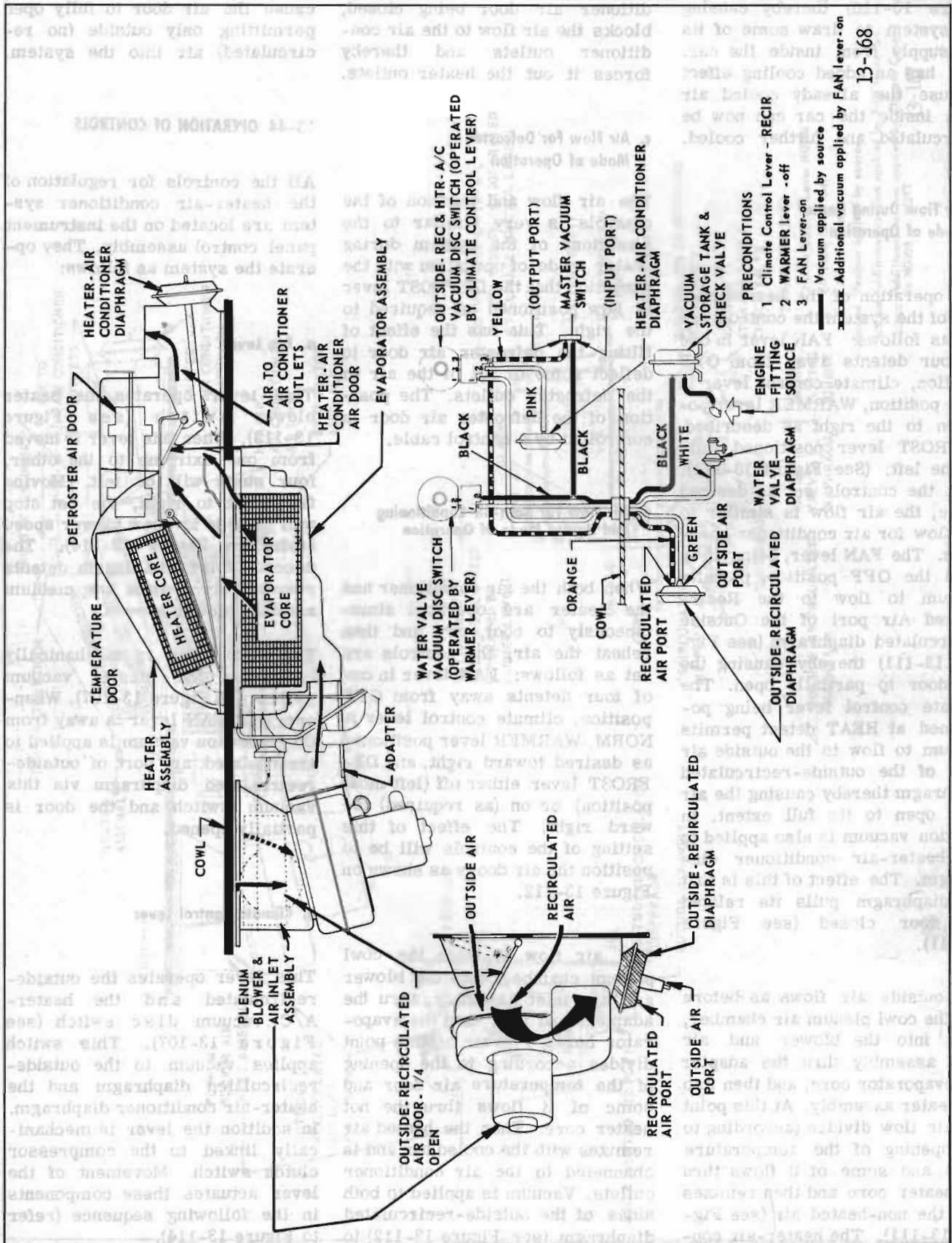

13-168

Figure 13-110—Air Conditioner Recirculate (Maximum) Heater Off (45-46-48000 Series)

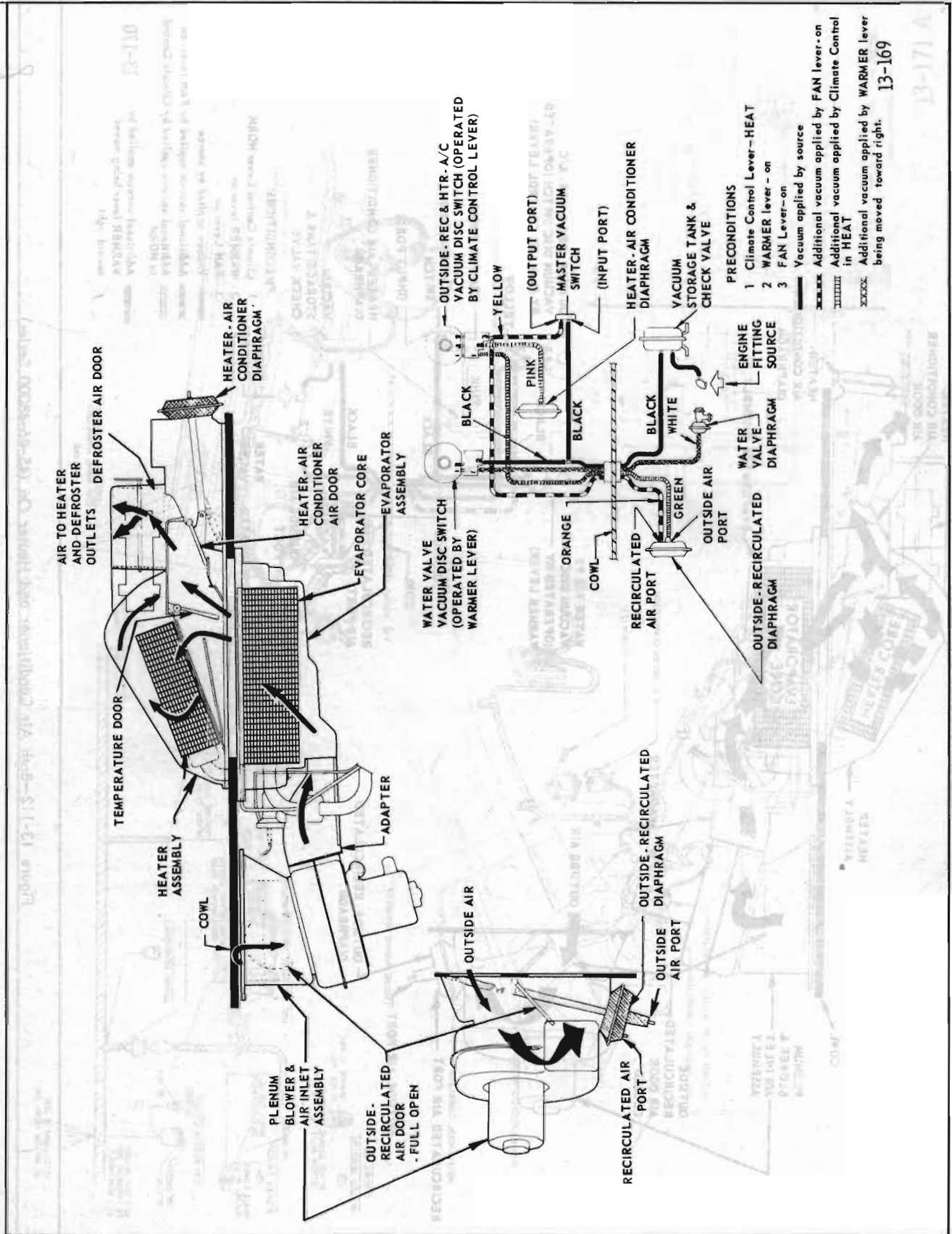

Figure 13-111—Air Conditioner Off, Heater On - 45-46-48000 Series

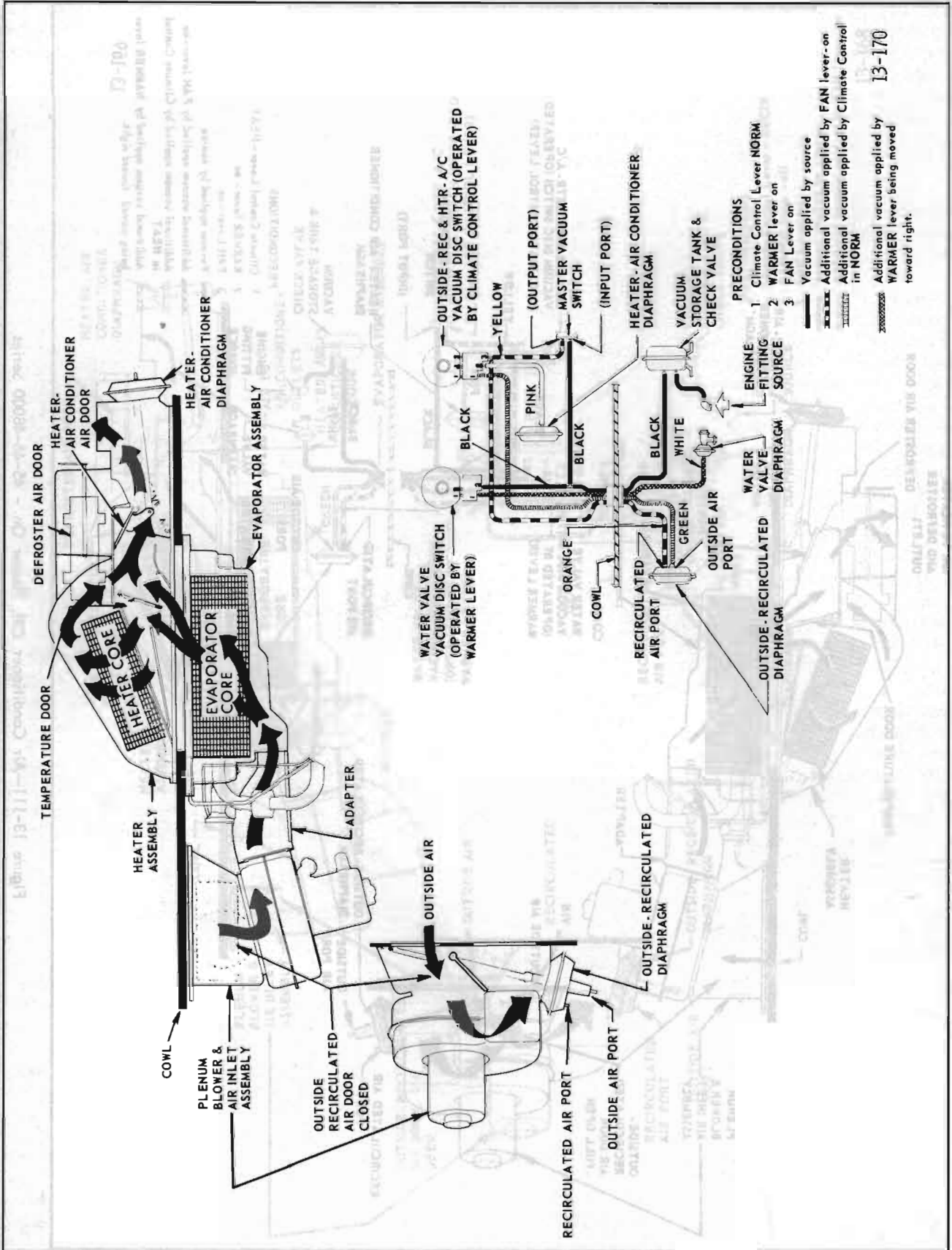

Figure 13-112—Both Air Conditioner and Heater On (45-46-48000 Series)

13-170

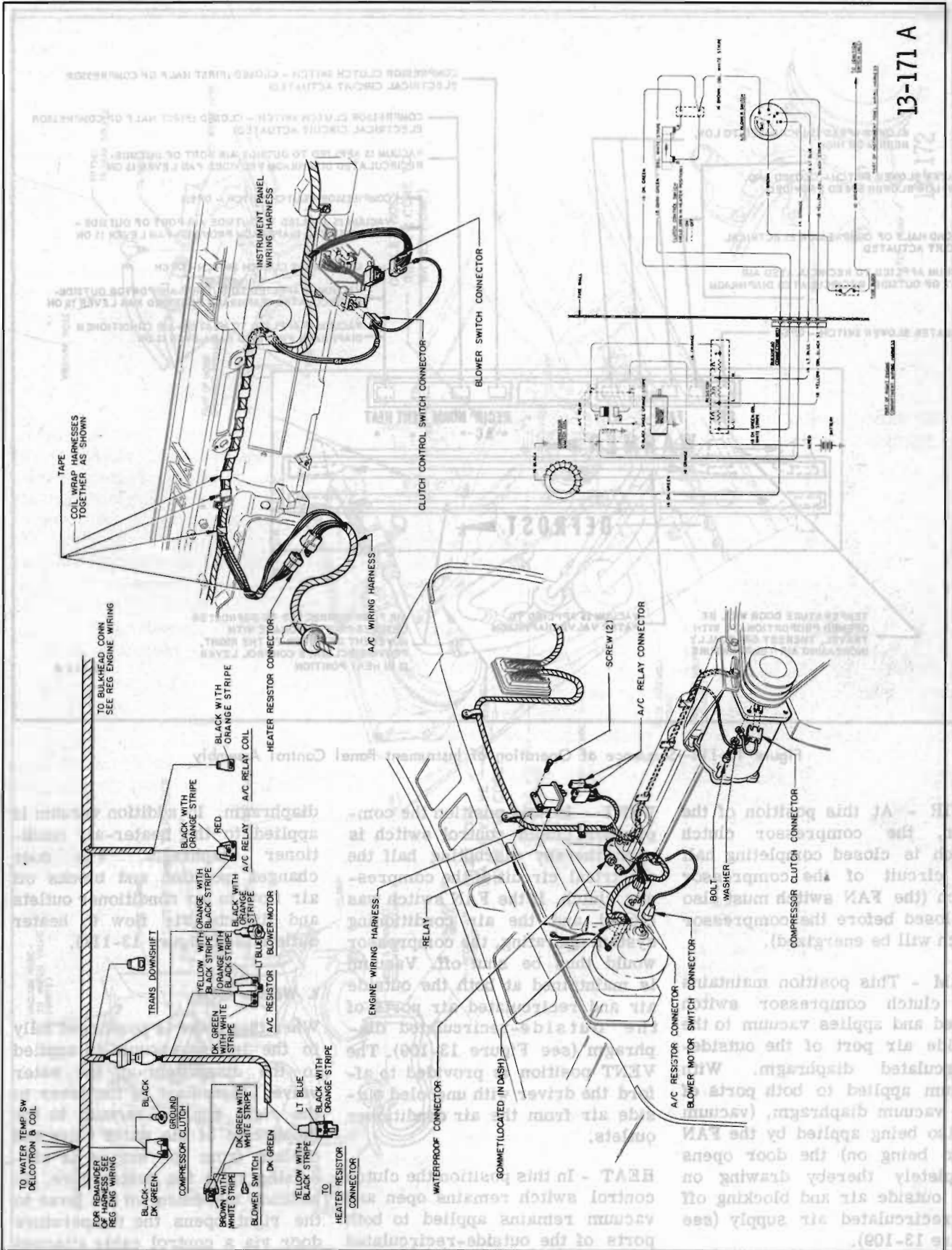

Figure 13-113—Electrical Layout of Heater - Air Conditioner System (45-46-48000 Series)

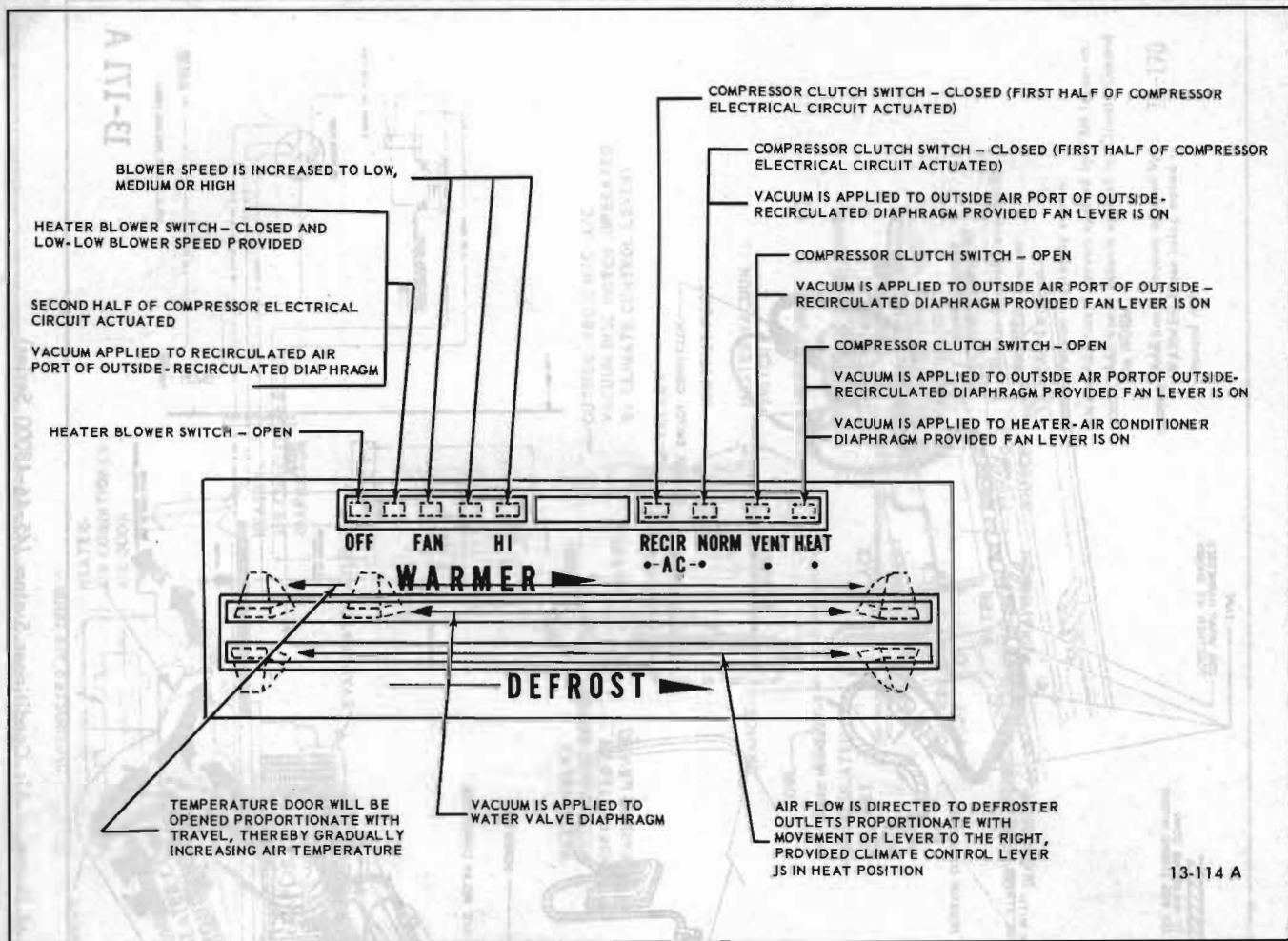

Figure 13-114—Sequence of Operation of Instrument Panel Control Assembly

RECIR - At this position of the lever, the compressor clutch switch is closed completing half the circuit of the compressor clutch (the FAN switch must also be closed before the compressor clutch will be energized).

NORM - This position maintains the clutch compressor switch closed and applies vacuum to the outside air port of the outside-recirculated diaphragm. With vacuum applied to both ports of this vacuum diaphragm, (vacuum is also being applied by the FAN lever being on) the door opens completely thereby drawing on only outside air and blocking off the recirculated air supply (see Figure 13-109).

VENT - In this position the compressor clutch control switch is open thereby disrupting half the electrical circuit of the compressor clutch. If the FAN switch was closed and the air conditioning system operating, the compressor would thus be shut off. Vacuum is maintained at both the outside air and recirculated air ports of the outside-recirculated diaphragm (see Figure 13-109). The VENT position is provided to afford the driver with uncooled outside air from the air conditioner outlets.

HEAT - In this position the clutch control switch remains open and vacuum remains applied to both ports of the outside-recirculated

diaphragm. In addition vacuum is applied to the heater-air conditioner diaphragm. The door changes position and blocks off air flow to air conditioner outlets and directs air flow to heater outlets (see Figure 13-111).

c. Warmer Lever

When this lever is positioned fully to the left no vacuum is applied to the diaphragm of the water valve. Movement of the lever to the right applies vacuum to the diaphragm of the water valve and coolant from the engine is circulated thru the heater core. In addition movement of the lever to the right opens the temperature door via a control cable attached

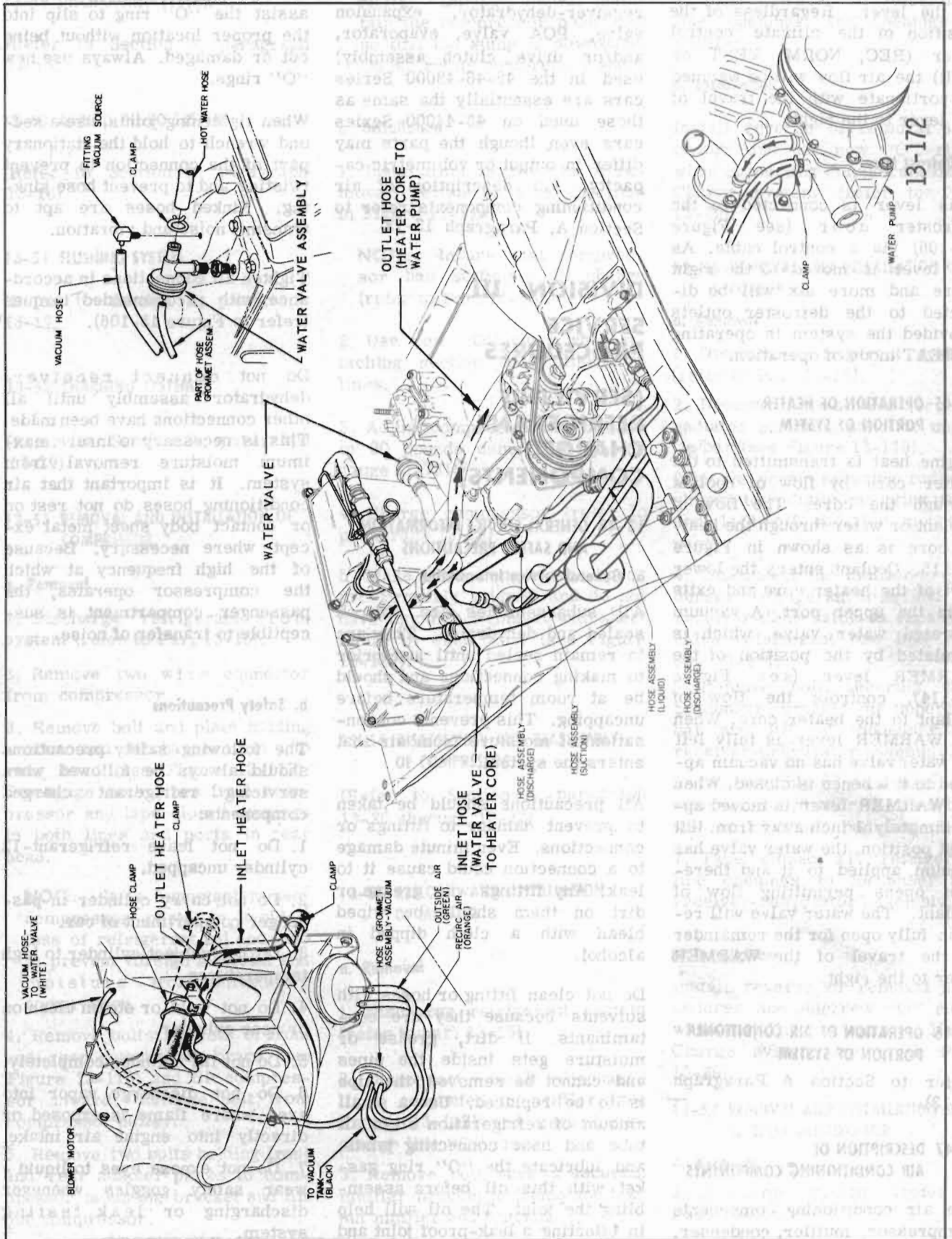

Figure 13-115—Heater Coolant Hose Installation (45-46-48000 Series)

to the lever. Regardless of the position of the climate control lever (REC, NORM, VENT or HTR) the air flow will be warmed proportionate with the travel of the lever to the right.

d. Defrost Lever

This lever is connected to the defroster door (see Figure 13-106) via a control cable. As the lever is moved to the right more and more air will be directed to the defroster outlets provided the system is operating in HEAT mode of operation.

13-45 OPERATION OF HEATER PORTION OF SYSTEM

Engine heat is transmitted to the heater core by flow of coolant through the core. The flow of coolant or water through the heater core is as shown in Figure 13-115. Coolant enters the lower port of the heater core and exits from the upper port. A vacuum operated water valve, which is regulated by the position of the WARMER lever (see Figure 13-114), controls the flow of coolant to the heater core. When the WARMER lever is fully left the water valve has no vacuum applied to it - hence is closed. When the WARMER lever is moved approximately 1 inch away from left most position, the water valve has vacuum applied to it and therefore opens permitting flow of coolant. The water valve will remain fully open for the remainder of the travel of the WARMER lever to the right.

13-46 OPERATION OF AIR CONDITIONER PORTION OF SYSTEM

(Refer to Section A Paragraph 13-13).

13-47 DESCRIPTION OF AIR CONDITIONING COMPONENTS

The air conditioning components (compressor, muffler, condenser,

receiver-dehydrator, expansion valve, POA valve, evaporator, and/or drive clutch assembly) used in the 45-46-48000 Series cars are essentially the same as those used on 43-44000 Series cars even though the parts may differ in output or volumetric capacity. For description of air conditioning components refer to Section A, Paragraph 13-13.

DIVISION III SERVICE PROCEDURES

(SERVICING REFRIGERANT CHARGED COMPONENTS)

13-48 GENERAL SERVICE INFORMATION AND SAFETY PRECAUTIONS

a. General Service Information

All subassemblies are shipped sealed and dehydrated. They are to remain sealed until just prior to making connections and should be at room temperature before uncapping. This prevents condensation of moisture from air that enters the system.

All precautions should be taken to prevent damage to fittings or connections. Even minute damage to a connection could cause it to leak. Any fittings with grease or dirt on them should be wiped clean with a cloth dipped in alcohol.

Do not clean fitting or hoses with solvents because they are contaminants. If dirt, grease or moisture gets inside the pipes and cannot be removed, the pipe is to be replaced. Use a small amount of refrigeration oil on all tube and hose connecting joints, and lubricate the "O" ring gasket with this oil before assembling the joint. The oil will help in effecting a leak-proof joint and

assist the "O" ring to slip into the proper location without being cut or damaged. Always use new "O" rings.

When tightening joints, use a second wrench to hold the stationary part of the connection to prevent twisting and to prevent hose kinking. Kinked hoses are apt to transmit noise and vibration.

Tighten all connections in accordance with recommended torques (refer to Figure 13-106).

Do not connect receiver-dehydrator assembly until all other connections have been made. This is necessary to insure maximum moisture removal from system. It is important that air conditioning hoses do not rest on or contact body sheet metal except where necessary. Because of the high frequency at which the compressor operates, the passenger compartment is susceptible to transfer of noise.

b. Safety Precautions

The following safety precautions should always be followed when servicing refrigerant charged components:

1. Do not leave refrigerant-12 cylinder uncapped.
2. Do not carry cylinder in passenger compartment of car.
3. Do not subject cylinder to high temperatures.
4. Do not weld or steam clean on or near cylinder.
5. Do not fill cylinder completely.
6. Do not discharge vapor into area where flame is exposed or directly into engine air intake.
7. Do not expose eyes to liquid - wear safety goggles whenever discharging or leak testing system.

13-49 DISCHARGING SYSTEM

(Refer to Section A, paragraph 13-15)

13-50 ADDING OIL TO SYSTEM

(Refer to Section A, paragraph 13-16)

13-51 FLUSHING SYSTEM

(Refer to Section A, paragraph 13-17)

13-52 CHARGING SYSTEM

(Refer to Section A, paragraph 13-29)

13-53 REMOVAL AND INSTALLATION OF COMPRESSOR**a. Removal**

1. Discharge refrigerant from system (refer to Par. 13-15).
2. Remove two wire connector from compressor.
3. Remove bolt and plate holding suction and discharge lines into rear head (see Figure 13-117). Disengage both lines from compressor and tape closed openings in both lines and ports in rear head.

NOTE: It is important to seal compressor ports to avoid a loss of refrigerant oil and also to prevent foreign material and moisture from entering compressor.

4. Remove bolts in slots of front and rear compressor brace (see Figure 13-118) and tilt compressor inward. Remove belt from compressor pulley.
5. Remove two bolts holding front and rear adapter plates to compressor mounting bracket and lift out compressor.

NOTE: During removal maintain the compressor positioned so that the sump is downward. Do not rotate compressor shaft.

b. Installation

1. Installation is reverse of removal; Torque bolts as specified in Figure 13-118.

NOTE: Insure that compressor has sufficient oil charge (refer to Par. 13-16).

2. Use new "O" rings when attaching suction and discharge lines.
3. Adjust compressor belt tension to 90 pounds using belt tension gauge (J-7316).
4. Charge compressor (refer to paragraph 13-29).

5. Make sure compressor hoses are properly aligned and do not have any direct contact with sheet metal or each other (see Figure 13-117).

13-54 DISASSEMBLY AND REASSEMBLY OF COMPRESSOR

(Refer to Section A, paragraph 13-20 through 13-22)

13-55 REMOVAL AND INSTALLATION OF MUFFLER**a. Removal**

1. Discharge refrigerant system (refer to par. 13-15).
2. Disconnect both discharge lines connected to muffler (see Figure 13-117) and discard discharge line "O" rings.
3. Remove both screws securing muffler bracket to frame and take out muffler and bracket.

4. Tape closed all refrigerant line openings and openings to muffler.

b. Installation

Install reverse of removal procedure and use new "O" rings when connecting refrigerant lines. Charge system (refer to Par. 13-29).

13-56 REMOVAL AND INSTALLATION OF CONDENSER**a. Removal**

1. Discharge refrigerant system (refer to Par. 13-15).
2. Remove three screws securing radiator mounting panel to upper tie bar (see Figure 13-119).
3. Move screw securing radiator shroud to radiator mounting panel and lift off radiator mounting panel.
4. Disconnect the muffler to condenser refrigerant line and the receiver-dehydrator to expansion valve refrigerant line (see Figure 13-117).
5. Remove bolt securing each condenser bracket to upper tie bar and lift out condenser and receiver-dehydrator assembly.
6. Disassembly of condenser and receiver-dehydrator assembly will be obvious upon inspection.
7. Tape closed all refrigerant line openings to condenser and receiver-dehydrator assembly.

b. Installation

Install reverse of removal procedures and use new "O" rings when installing refrigerant lines. Charge system (refer to Par. 13-29).

13-57 REMOVAL AND INSTALLATION OF RECEIVER-DEHYDRATOR**a. Removal**

1. Discharge system (refer to Par. 13-15).

2. Disconnect receiver-dehydrator to expansion valve refrigerant line, and also receiver-dehydrator to condenser refrigerant line. Discard "O" rings. See Figure 13-117.

3. Remove two screws securing receiver-dehydrator clamps to condenser side bracket, bend open clamps and remove receiver-dehydrator.

4. Tape closed all refrigerant line openings and openings in receiver-dehydrator.

b. Installation

Install reverse of removal procedures and use new "O" rings when installing refrigerant lines. Charge system (refer to Par. 13-29).

13-58 REMOVAL AND INSTALLATION OF EXPANSION VALVE

a. Removal

1. Discharge system (refer to Par. 13-15).

2. Disconnect equalizer line situated between expansion valve and POA valve from connecting point on POA valve. (See Figure 13-120).

3. Peel away black insulating putty from around outlet pipe of evaporator and disconnect expansion valve bulb from outlet pipe.

4. From underside of car remove screw securing expansion valve to bracket (see Figure 13-120) disconnect expansion valve to receiver-dehydrator refrigerant line from valve. Unscrew nut holding expansion valve to evaporator assembly and remove valve. Discard all "O" rings from disconnected lines.

5. Tape closed all refrigerant line openings and openings in expansion valve.

b. Installation

Install reverse of removal and use new "O" rings when installing refrigerant lines. Charge system (refer to Par. 13-29).

WARNING: When installing expansion valve care should be taken not to kink capillary tube connecting bulb with expansion valve.

13-59 REMOVAL AND INSTALLATION OF EVAPORATOR

a. Removal

1. Discharge refrigerant system (refer to Par. 13-15).

2. Disconnect oil bleed line and equalizer line from POA valve (see Figure 13-117).

3. Peel back black insulating putty from around evaporator assembly outlet pipe and disconnect expansion valve bulb.

4. Unscrew fastener securing POA valve to evaporator outlet pipe and remove two screws securing POA valve bracket to evaporator. Reposition POA valve out of way.

5. Disconnect clips from side of evaporator that secure expansion valve lines in place.

6. From underside of car unscrew nut holding expansion valve to evaporator assembly.

7. Disconnect any vacuum hoses or electrical wires attached to clips along topside of evaporator.

8. From under instrument panel remove three screws securing bottom side of evaporator to cowl (see Figure 13-121).

9. Remove six screws securing evaporator assembly to cowl and lift out POA and evaporator as an assembly.

10. Tape closed all refrigerant line openings and openings in expansion valve, POA valve, and evaporator assembly.

b. Installation

Install reverse of removal procedures and use new "O" rings when installing refrigerant lines. Charge system (refer to Par. 13-29).

13-60 REMOVAL AND INSTALLATION OF POA VALVE

a. Removal

1. Discharge refrigerant circuit (refer to Par. 13-15).

2. Disconnect equalizer and oil bleed lines from POA valve (see Figure 13-117).

3. Unscrew nut holding POA valve to evaporator outlet pipe.

4. Remove screw securing POA valve clamp to bracket on evaporator assembly and lift out POA valve.

5. Tape closed all openings to refrigerant lines and openings to evaporator and POA valve.

b. Installation

Install reverse of removal procedures and use new "O" rings when installing refrigerant lines. Charge system (refer to Par. 13-29).

(SERVICING AIR DISTRIBUTION COMPONENTS)

13-61 REMOVAL AND INSTALLATION OF PLENUM BLOWER AND AIR INLET ASSEMBLY

a. Removal

1. Disconnect blower motor ground wire from plenum blower and air inlet assembly (see Figure 13-120) and blower motor connector.

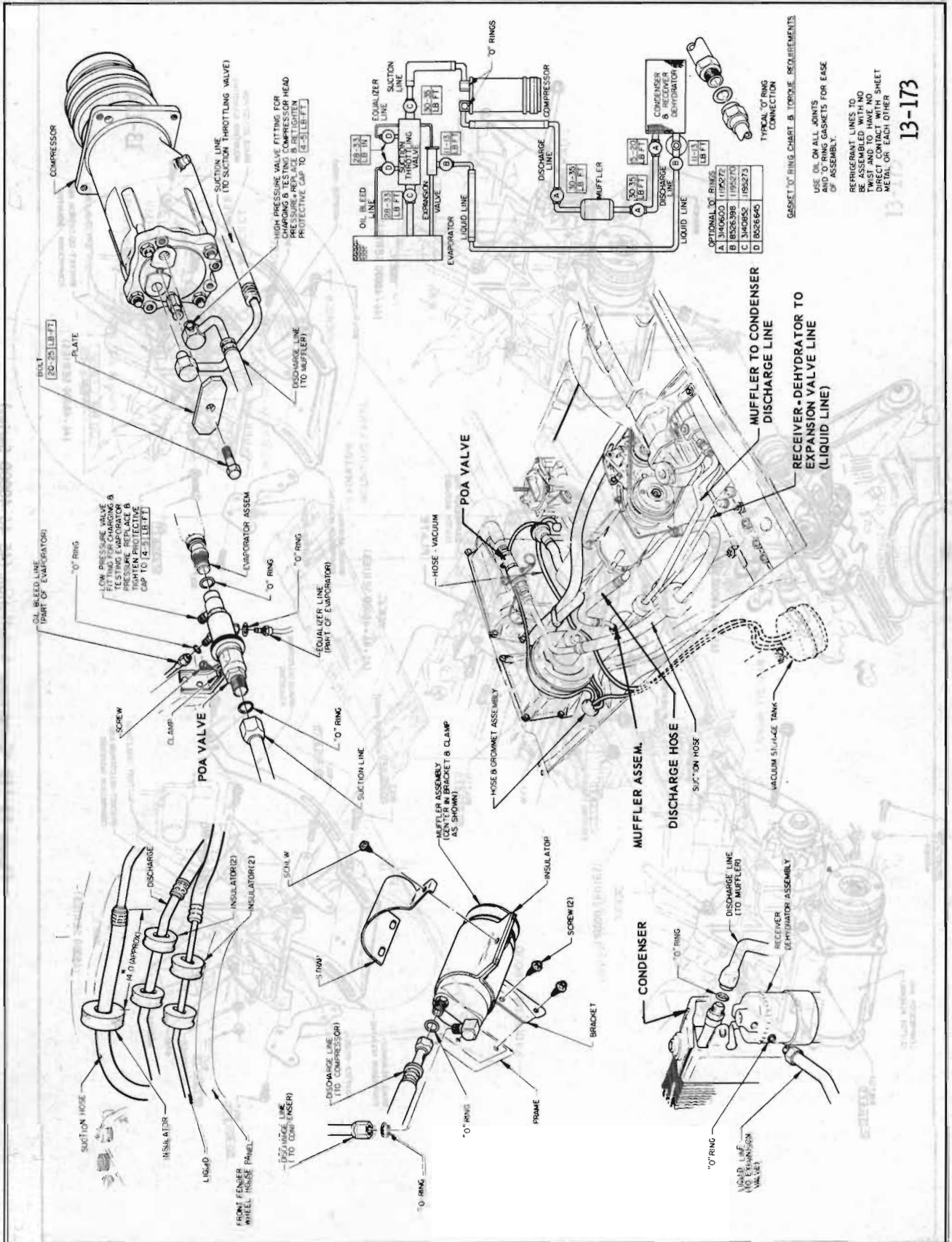
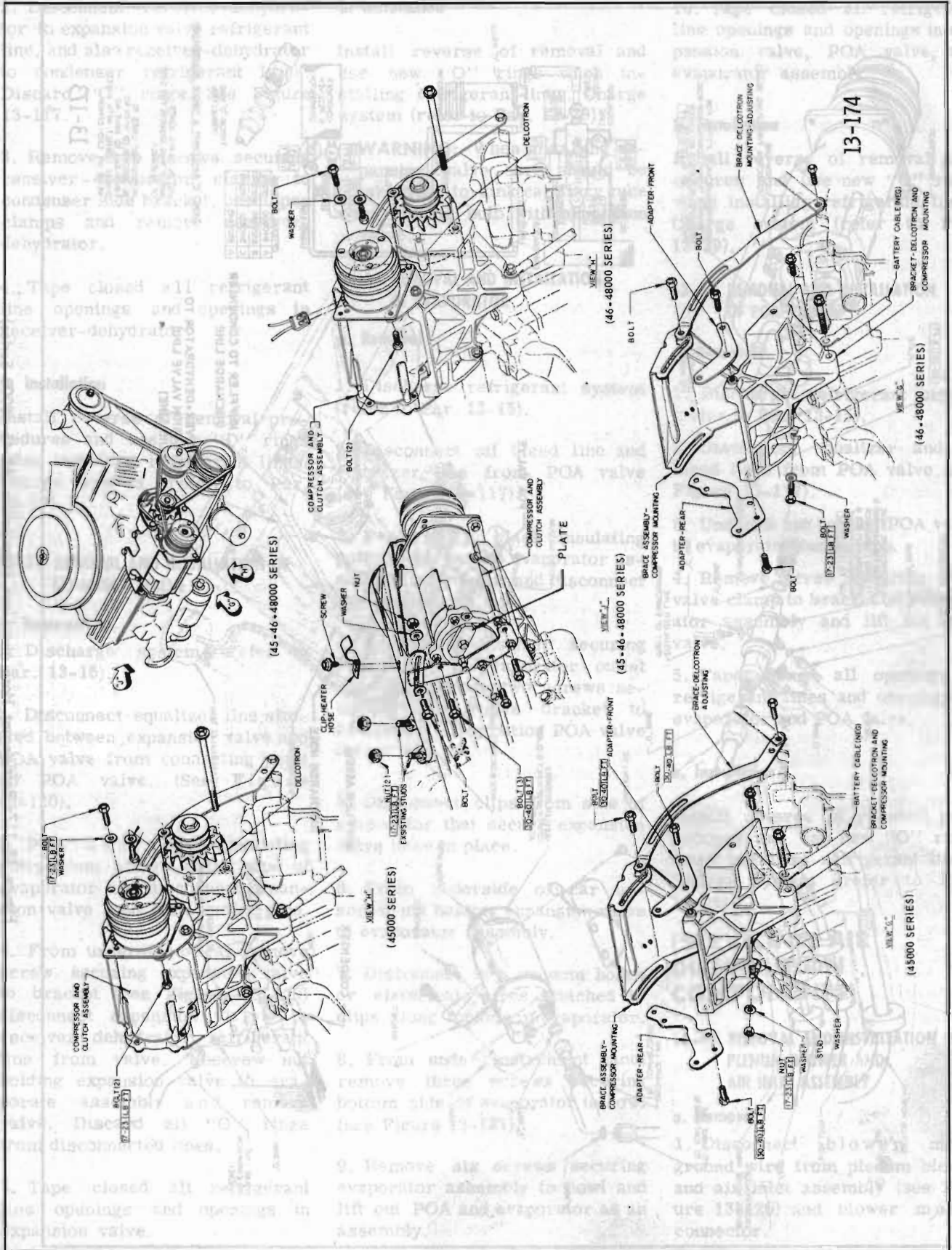
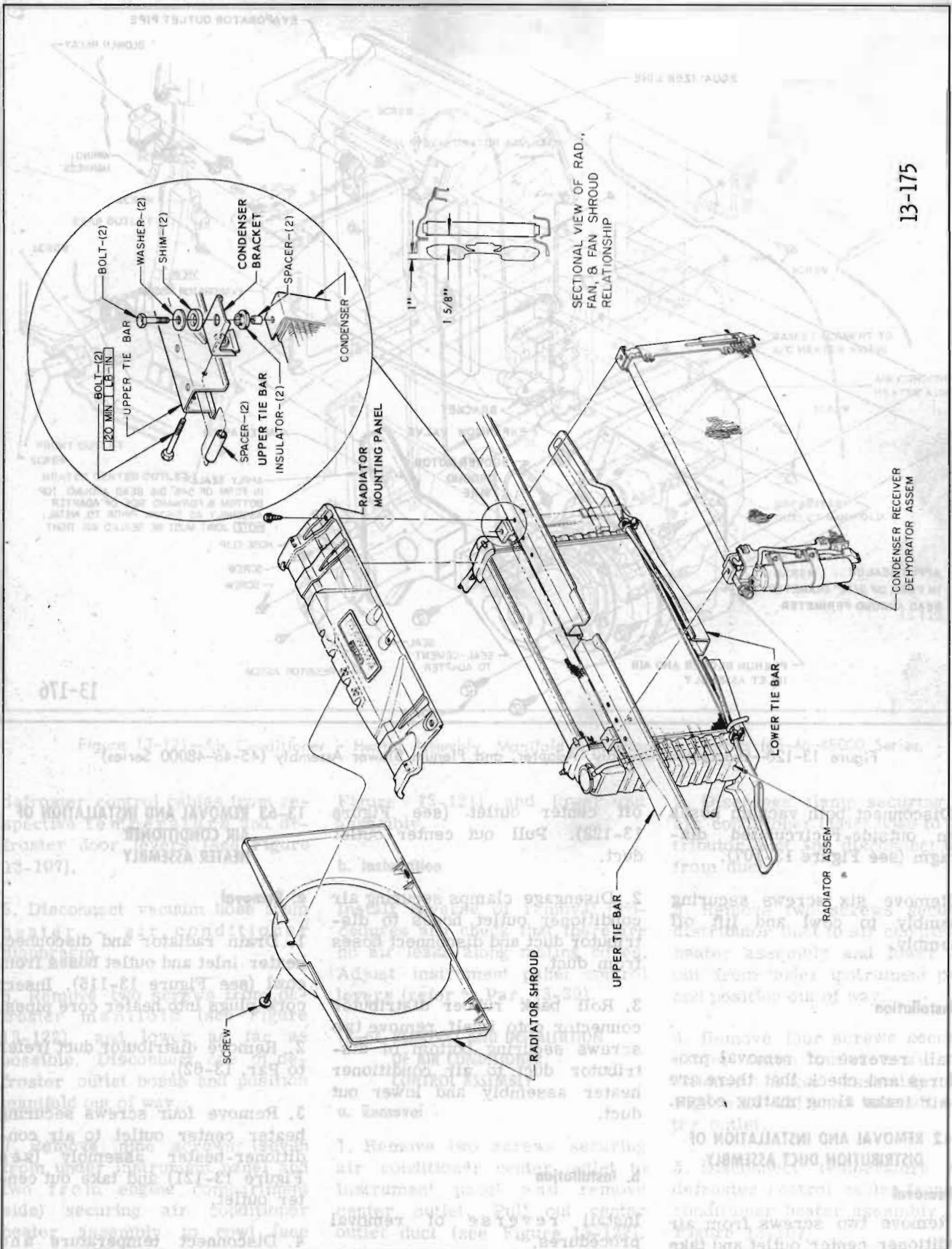

Figure 13-117—Refrigerant Hose and Lines Installation (45-46-48000 Series)



13-174

Figure 13-118—Compressor Installation (45-46-48000 Series)



13-175

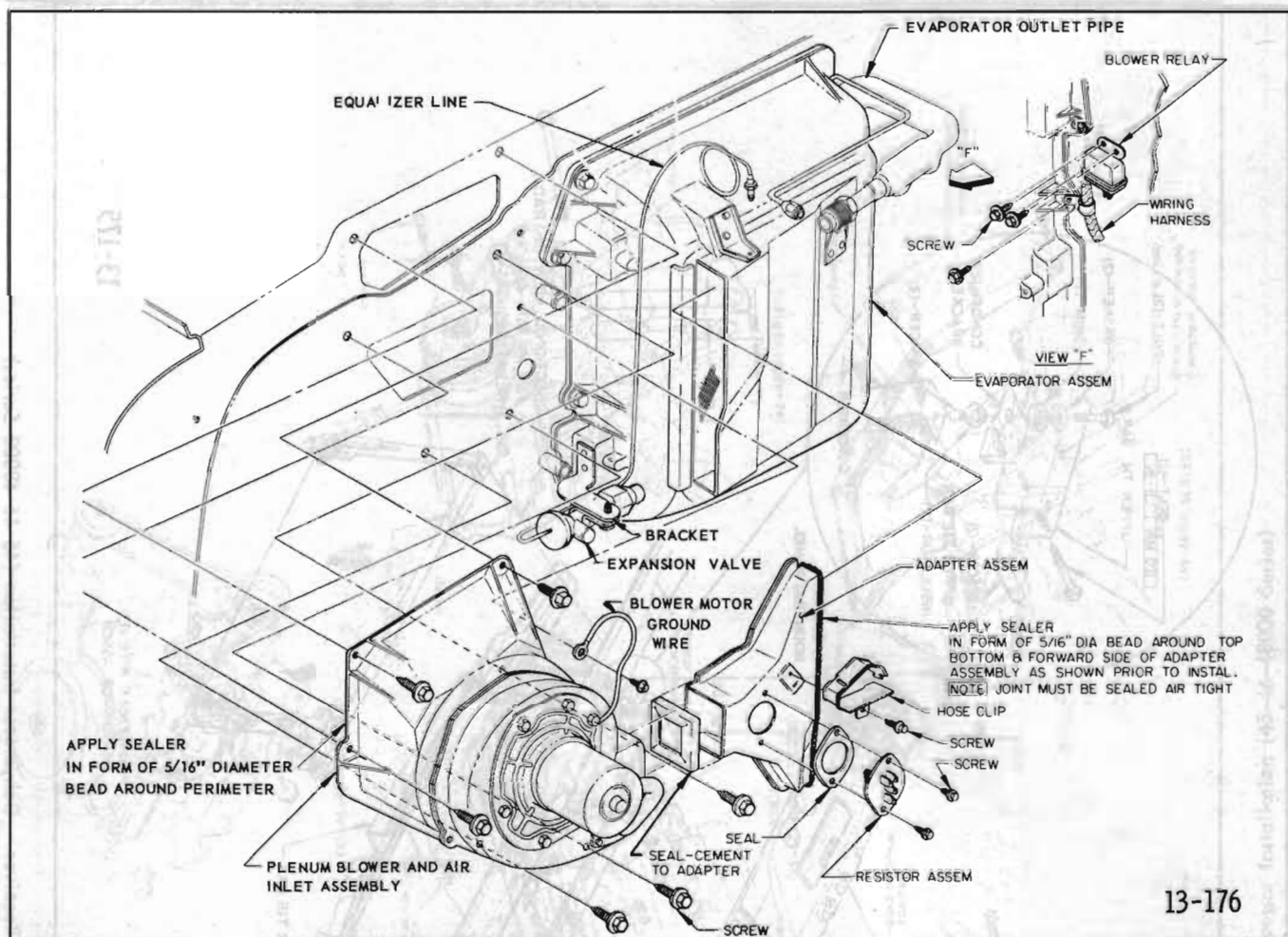

13-176

Figure 13-120—Evaporator Assembly, Adapter, and Plenum Blower Assembly (45-46-48000 Series)

2. Disconnect both vacuum hoses from outside-recirculated diaphragm (see Figure 13-107).

3. Remove six screws securing assembly to cowl and lift off assembly.

b. Installation

Install reverse of removal procedures and check that there are no air leaks along mating edges.

13-62 REMOVAL AND INSTALLATION OF DISTRIBUTION DUCT ASSEMBLY

a. Removal

1. Remove two screws from air conditioner center outlet and take

off center outlet (see Figure 13-122). Pull out center outlet duct.

2. Disengage clamps securing air conditioner outlet hoses to distributor duct and disconnect hoses from duct.

3. Roll back rubber distributor connector onto itself, remove two screws securing bottom of distributor duct to air conditioner heater assembly and lower out duct.

b. Installation

Install reverse of removal procedures.

13-63 REMOVAL AND INSTALLATION OF AIR CONDITIONER HEATER ASSEMBLY

a. Removal

1. Drain radiator and disconnect heater inlet and outlet hoses from cowl (see Figure 13-115). Insert cork plugs into heater core pipes.

2. Remove distributor duct (refer to Par. 13-62).

3. Remove four screws securing heater center outlet to air conditioner-heater assembly (see Figure 13-121) and take out center outlet.

4. Disconnect temperature and

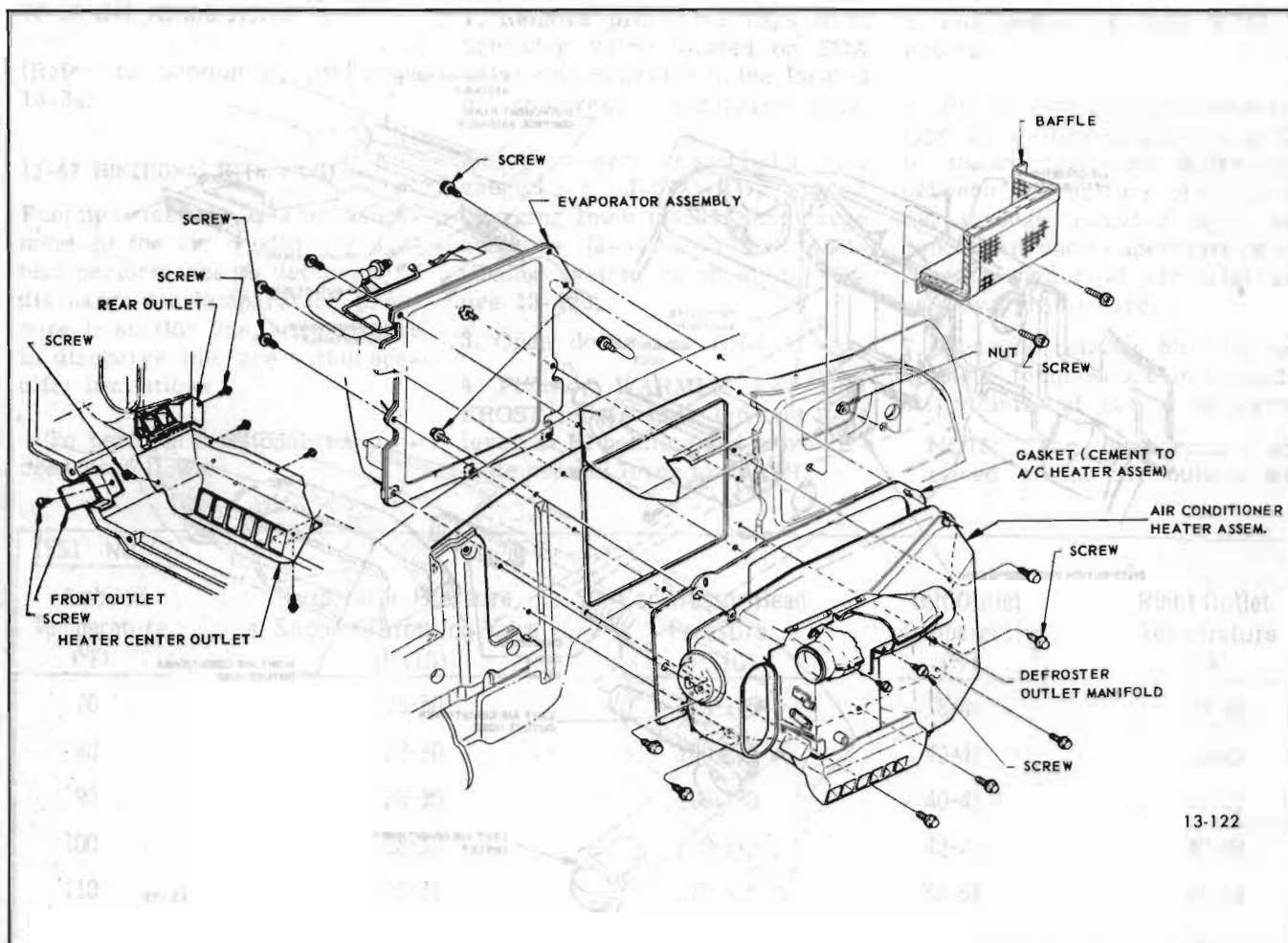

13-122

Figure 13-121—Air Conditioner - Heater Assembly, Manifold and Attaching Outlets (45-46-48000 Series,

defroster control cables from respective temperature and defroster door levers (see Figure 13-107).

5. Disconnect vacuum hose from heater - air conditioner diaphragm.

6. Remove two screws from defroster manifold (see Figure 13-122), and lower as far as possible. Disconnect one of defroster outlet hoses and position manifold out of way.

7. Remove nine screws (seven from under instrument panel and two from engine compartment side) securing air conditioner heater assembly to cowl (see

Figure 13-121) and lower out assembly.

b. Installation

Install reverse of removal procedures and check that there are no air leaks along mating edges. Adjust instrument panel control levers (refer to Par. 13-39).

13-64 REMOVAL AND INSTALLATION OF AIR CONDITIONER CONTROL ASSEMBLY

a. Removal

1. Remove two screws securing air conditioner center outlet to instrument panel and remove center outlet. Pull out center outlet duct (see Figure 13-122).

2. Disengage clamp securing left air conditioner outlet hose to distributor duct and disconnect hose from duct.

3. Remove two screws securing distributor duct to air conditioner heater assembly and lower duct out from under instrument panel and position out of way.

4. Remove four screws securing heater center outlet to air conditioner heater assembly (see Figure 13-121) and take off center outlet.

5. Disconnect temperature and defroster control cables from air conditioner heater assembly (see Figure 13-107).

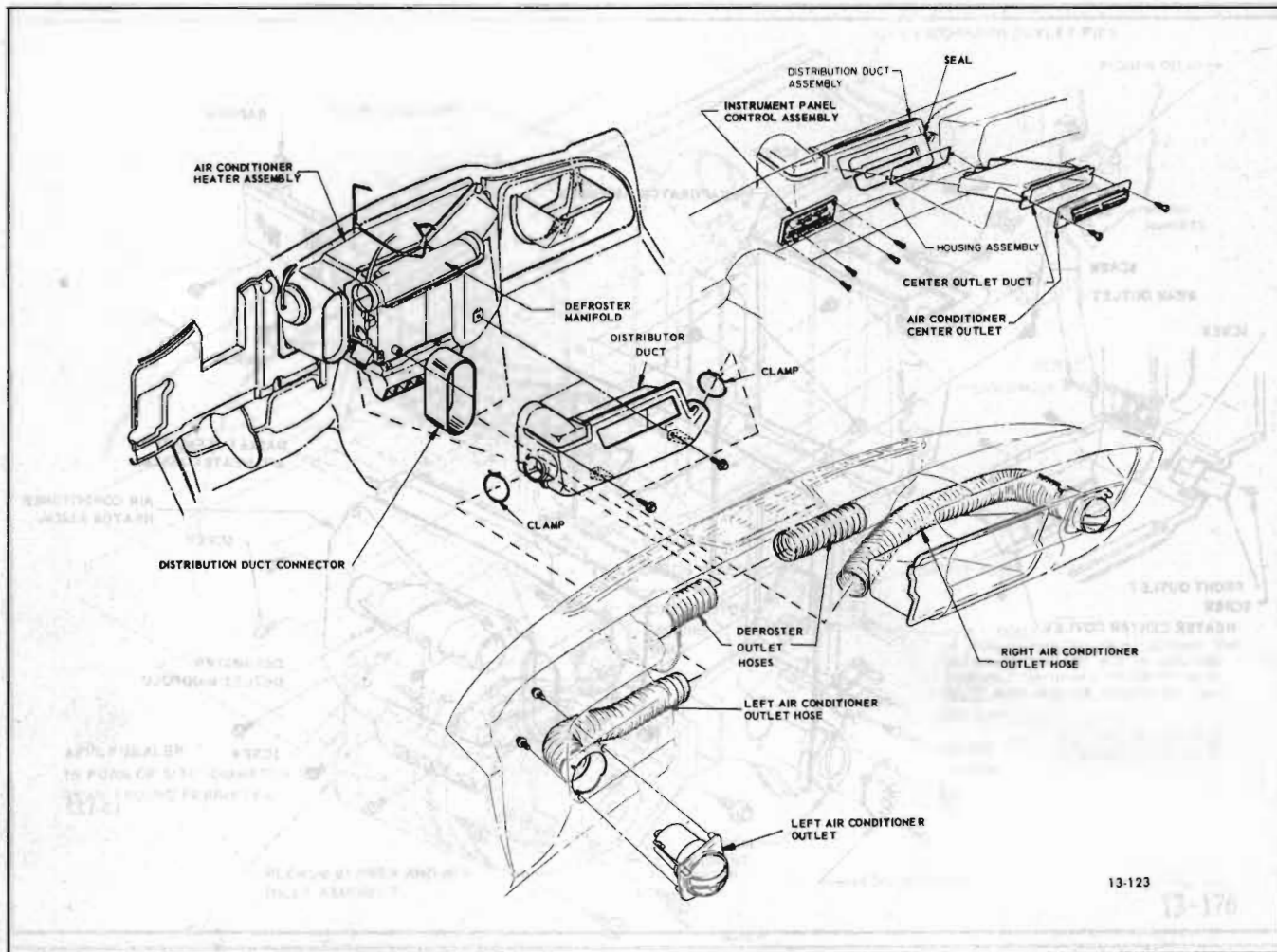

Figure 13-122—Distribution Duct Assembly (45-46-48000 Series)

6. Disconnect rubber vacuum hose plugs from rear of instrument panel control assembly (see

Figure 13-107). Also disconnect vacuum hoses from master vacuum switch and electrical connec-

tors from compressor clutch and heater blower switches.

7. Remove four screws securing instrument panel control assembly to instrument panel and partially withdraw assembly. Disconnect lamp sockets and complete removal of assembly.

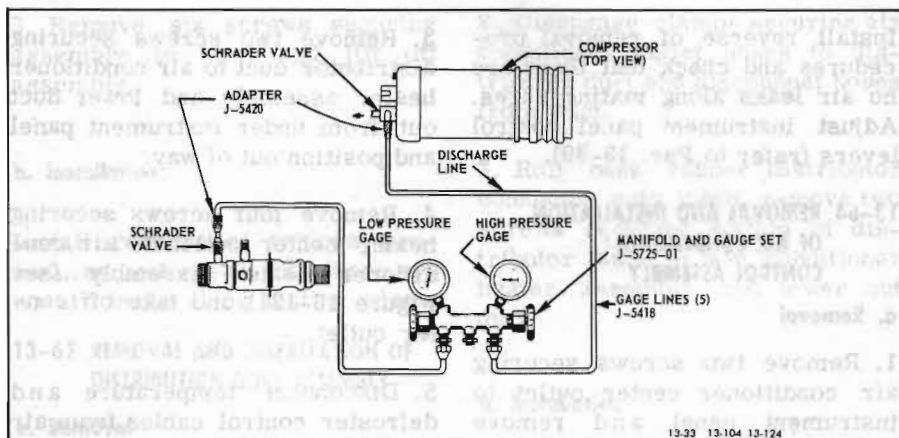

Figure 13-123—Functional Test Set-up

b. Installation

Install reverse of removal procedures and adjust control cables (refer to Par. 13-39).

**DIVISION IV
TROUBLE DIAGNOSIS**

13-65 GENERAL INFORMATION

(Refer to Section A, paragraph 13-33)

13-66 LEAK TESTING SYSTEM

(Refer to Section A, paragraph 13-34)

13-67 FUNCTIONAL TESTING SYSTEM

Function testing is a measurement of the air conditioner system performance to determine if discharge air temperature, pressure in suction line, and pressure in discharge line are within specific limitations.

To perform functional test proceed as follows:

1. Remove protective caps from Schrader valve located on POA valve and Schrader valve located on compressor discharge port.
2. Interconnect manifold and gauge set (J-5725-01), gauge charging lines (J-5418) and gauge adaptors (J-5420) to air conditioning system as shown in Figure 13-123.
3. Open doors and hood of car.
4. Position WARMER and DEFROST levers fully left; set FAN lever at HI position and move climate control lever to RECIR.

5. Idle engine at 2000 RPM in neutral.

6. Place a high volume industrial type fan in front of radiator grille to insure minimum differential between temperature of air passing through radiator grille and condenser, and temperature of air flow through cowl air inlet and past evaporator core.

7. Measure relative humidity and ambient temperature in immediate vicinity of car to be tested.

NOTE: The temperature obtained at the air outlets will

TEST NO. 1

Ambient Temperature (°F)	Evaporator Pressure at Suction Throttling Valve (PSIG)	Compressor Head Pressure (PSIG)	Left Outlet Temperature (°F)	Right Outlet Temperature (°F)
70	28-30	160-195	38-41	39-43
80	28-30	180-235	40-43	40-45
90	28-30	200-280	40-45	40-45
100	28-30	230-310	42-47	42-48
110	28-31	270-335	44-52	46-53

TEST NO. 2

Ambient Temperature (°F)	Relative Humidity	Engine R. P. M.	Evaporator Pressure at Suction Throttle Valve (PSIG)	Compressor Head Pressure (PSIG)	Left Outlet Temperature (°F)	Right Outlet Temperature (°F)
70	Dry	410-435	28	120	40	40
70	Humid	450-475	35	148	46	47
80	Dry	400-435	31	156	44	44
80	Humid	690-715	35	200	50	50
90	Dry	415-440	35	178	47	47
90	Humid	765-790	35	225	51	54
100	Dry	620-670	35	225	48	48
100	Humid	950-1000	35	267	54	56
110	Dry	775-825	35	260	50	50
110	Humid	1225-1275	35	317	55	56

Figure 13-124—Air Conditioner Functional Test Table (45-46-48000 Series)

13-125

13-68 HEATER-AIR CONDITIONER VACUUM AND ELECTRICAL CIRCUITS
TEST SEQUENCE AND TROUBLE DIAGNOSIS TABLE (45-46-48000 SERIES)

Sequence of Operation of Controls	Changes That Should Take Place in the System	Possible Cause of Malfunctions
<p>Pre Conditions— FAN lever—OFF Climate Control Lever-RECIR WARMER lever—fully left DEFROST lever—fully left Engine Idling</p> <p>Move FAN lever to 1st detent.</p>	<p>Master vacuum switch will open and apply vacuum to recirculate port of outside-recirculate diaphragm. Outside-recirculate air door will open 1/4 of complete travel.</p> <p>The blower will operate at low blower speed and air will flow from air conditioner outlets.</p> <p>The compressor clutch will engage.</p>	<p>Kinked, plugged or disconnected hose.</p> <p>Outside - rec. diaphragm. defective.</p> <p>Outside - rec. air door sticking.</p> <p>Master vacuum switch defective or misadjusted.</p> <p>Defective vacuum storage tank.</p> <p>Vacuum hoses on wrong ports on vacuum diaphragm.</p> <p>Vacuum hoses incorrectly assembled to connector plug on cowl or to plug on vacuum disc switch.</p> <p>Defective compressor clutch switch.</p> <p>Defective resistor assembly.</p> <p>Defective blower motor.</p> <p>Loose or broken wire.</p> <p>Fuse</p> <p>Defective heater blower switch.</p> <p>NOTE: If only one blower is available regardless of switch position, it is likely resistor assembly coils are touching.</p> <p>NOTE: If air flows from the heater outlets, or flows from both the heater and the A/C outlets it is possible that the spring which holds the door in position is broken.</p> <p>Defective compressor clutch switch.</p> <p>Loose or broken wire.</p>

Sequence of Operation of Controls	Changes That Should Take Place in the System	Possible Cause of Malfunctions
<p>Move FAN lever to 1st detent (Cont'd.)</p>		<p>Defective compressor clutch coil.</p> <p>Compressor clutch ground wire broken.</p> <p>Connector loose at compressor coil.</p> <p>NOTE: If neither the blower motor nor the compressor can be actuated-check the fuse and the blower switch.</p>
<p>Move the FAN lever thru 2nd, 3rd and 4th detents</p>	<p>Blower will increase speed to low, medium and high.</p>	<p>Defective blower resistor assembly</p> <p>Defective blower switch.</p> <p>NOTE: If no high blower speed, check A/C relay.</p>
<p>Move Climate Control lever to NORM.</p>	<p>Vacuum will be applied to outside air port of outside-rec. diaphragm thereby fully opening door.</p>	<p>Kinked hose.</p> <p>Outside - rec. diaphragm defective.</p> <p>Outside - rec. door sticking.</p> <p>Outside - rec. & htr. - A/C vacuum disc switch defective.</p>
<p>Move Climate Control to VENT.</p>	<p>Compressor clutch will disengage.</p>	<p>Defective compressor clutch switch.</p> <p>Defective wiring.</p>
<p>Move Climate Control to HEAT.</p>	<p>Vacuum will be applied to htr. -A/C diaphragm and door will reposition directing air out of heater outlets.</p>	<p>Kinked or pinched hoses.</p> <p>Htr - A/C diaphragm defective.</p> <p>Outside - rec. & htr. - A/C vacuum disc switch defective.</p> <p>Sticking htr. - A/C door.</p> <p>Disconnected or misconnected hoses at connector plug on cowl.</p>
<p>Move WARMER lever fully to right.</p>	<p>Vacuum will be applied to diaphragm of water valve and open valve permitting coolant to circulate thru heater core. Warm air will flow from heater outlets.</p>	<p>Kinked vacuum hoses.</p> <p>Defective water valve vacuum disc switch.</p> <p>Incorrect vacuum hose connection vacuum diaphragm or connector plug on cowl.</p> <p>Kinked water hoses.</p> <p>Defective water valve.</p> <p>Plugged heater core.</p>

Sequence of Operation of Controls	Changes That Should Take Place in the System	Possible Cause of Malfunctions
Move DEFROST lever fully to the right.	The temperature door will open permitting air to circulate past the heater core. Air will be directed to defroster outlets.	Broken, defective or misadjusted control cable. Broken, defective, disconnected or misadjusted control cable.

13-69 HEATER-AIR CONDITIONER REFRIGERANT CIRCUIT TROUBLE DIAGNOSIS CHART

(Refer to Section A, paragraph 13-37.)

Code	Description	Symptom	Division
13-87	I
13-88	I
13-89	I
13-90	I
13-91	I
13-92	I
13-93	I
13-94	I
13-95	I
13-96	I
13-97	I
13-98	I
13-99	I
13-100	I
13-101	I
13-102	I
13-103	I
13-104	I
13-105	I
13-106	I
13-107	I
13-108	I
13-109	I
13-110	I
13-111	I
13-112	I
13-113	I
13-114	I
13-115	I
13-116	I
13-117	I
13-118	I
13-119	I
13-120	I
13-121	I
13-122	I
13-123	I
13-124	I
13-125	I
13-126	I
13-127	I
13-128	I
13-129	I
13-130	I

NOTE: ...