

SECTION B

45-46-48000 CHASSIS SHEET METAL

CONTENTS

| Division | Paragraph | Subject | Page |
|----------|-----------|---|--------|
| I | | SPECIFICATIONS AND ADJUSTMENTS: | |
| | 110-10 | Fender, Bumper and Hood Adjustment Inspection | 110-20 |
| | 110-11 | Fender, Bumper and Hood Adjustment | 110-21 |
| II | | DESCRIPTION AND OPERATION: | |
| | 110-12 | Description of Chassis Sheet Metal | 110-23 |
| III | | SERVICE PROCEDURES: | |
| | 110-13 | Removal and Installation of Hood Assembly | 110-23 |
| | 110-14 | Removal and Installation of Hood Hinge Spring | 110-23 |
| | 110-15 | Removal and Installation of Hood Hinge | 110-23 |
| | 110-16 | Removal and Installation of Fender and Skirt | 110-23 |
| IV | | TROUBLE DIAGNOSIS: | |
| | 110-17 | Trouble Diagnosis of Chassis Sheet Metal | 110-24 |

DIVISION I

SPECIFICATIONS AND ADJUSTMENTS

110-10 FENDER, BUMPER AND HOOD ALIGNMENT INSPECTION

When the front sheet metal is misaligned, it is imperative to make the correct adjustment since an incorrect move on one item can throw the error to another area. Therefore, it is necessary to analyze the sheet metal as a whole before adjustments are made. For best results, the following procedure should be used:

a. Preliminary Tightening

Before deciding upon any adjustment to correct hood or fender misalignment, it is advisable to check tightness of all attaching screws and bolts since a true

picture of the correction requirements cannot be obtained when the sheet metal is loose and free to shift.

After all parts are properly tightened, inspect fender and hood alignment (subpar. b.) and hood alignment (subpar. c.). Make all inspections before performing any adjustments because an adjustment at one point will usually alter alignment at other points. The preliminary inspection should determine the adjustments that will produce the best overall alignment of hood and fenders at all points.

b. Fender and Hood Alignment at Front Doors

1. Fender to leading edge of door should have a 3/16" parallel gap and be flush. If realignment is necessary, check what this move will do to the rear end of the hood opening (approximately 1/8" gap

between fenders and hood). The total gap of both sides should be approximately 1/4" regardless of how the hood is spaced. If moving the fender flush with the door will impair this gap too badly, the door must be moved to make it flush with the fender.

Before making any adjustment of sheet metal to provide necessary clearance, first make sure that front doors are properly aligned in the body openings. If fenders and door panel surfaces are not reasonably flush, correction may be made by adding or removing shims between the fender and the cowl. See Figures 110-18 and 110-19.

2. The fender to cowl vent and top edge of door should be flush and parallel to the vent.

3. If the hood to fender gap at the rear is correct, the hood split line should be parallel the full length of the hood with the nose of

the hood aligning with the tips of the fenders.

4. The hood should be flush with the fenders from front to rear. When the hood and fender split lines are parallel from front to rear and the fender on one side is short of the hood nose while the other side is flush or long of the hood nose, it is necessary to shift the front end of the chassis sheet metal (attached at chassis frame on each side of radiator) in the direction of the short fender. Some variation of parallel lines and hood to fender nose flushness can be allowed in mild cases, but shifting the sheet metal is the only way a correct alignment can be obtained. Before you have decided this is the move to make, be sure that the rear ends of the fenders are not inboard to the door on one side and outboard on the other; this will have the same effect on out-of-square sheet metal. The hood is the final adjustment item on sheet metal and will not fit in, and meet specification in an opening that is not square.

c. Hood Alignment Inspection

When the hood is closed and latched, it should bear firmly against the front rubber bumpers on upper tie bar. Height of hood and width of space between hood and fenders should be reasonably even from front to rear.

110-11 FENDER, BUMPER AND HOOD ADJUSTMENT

a. Poor Fender to Door Gap (But Parallel)

To move a fender fore or aft, it is necessary to loosen all attachments to the body (one at the hood hinge area, one at the front of dash slightly below the hood hinge, one at the lower portion of dash attaching to inner fender skirt, one at the door hinge pillar

with the car door open and two at the rocker-rear lower end of fender).

Many times after loosening these attachments, the fender will spring to its proper position although this shouldn't happen. If the move isn't too great, the fender can be slightly forced to its correct position; but if too much force is necessary to obtain this setting, further procedures should be used. (Remember that putting the fender under severe strain can result in only a temporary alignment or a change in the door line or hood split line contour; this can also cause the fender at the rocker at the rear of the wheel cut to flare out or in.)

When a major move is necessary, remove the battery and battery base, radiator support side reinforcements, and loosen all sheet metal attachments of the chassis sheet metal to radiator support of both fenders even if only one is to be relocated. Bolts to loosen are fender skirt (wheel house panel) radiator support, fender to radiator support (behind headlamps). Do not loosen the upper tie bar to fender bolts. Loosen the chassis sheet metal to frame bolts located at each side of the radiator on the side to be relocated.

NOTE: When necessary to make side-to-side adjustments, loosen the radiator braces on models so equipped.

When all bolts are loose, the sheet metal can shift to any desired position. It is not necessary to remove the hood, but the hood should be in the open position when sheet metal is shifted.

From this point, it is very important to secure the previously loosened bolts in the following sequence:

Before any tightening is performed at this stage, it should have been determined whether the

fender and door will have a parallel gap when set at the correct height at the rear. If correction is needed to make the gap parallel, the sheet metal must be raised or lowered at the chassis sheet metal mounts by adding or removing shims between the radiator support and the mount. Remember that the mount is compressed after tightening and will account for approximately 1/16" smaller gap on the bottom of the door opening than at the top.

1. Tighten the vertical fender to body attachment point first. Add or remove shims to position the fender vertically to door and vent grille. Position the fender and door with a 3/16" gap and flush to the door at the upper portion of fender to door. The vent grille and fender must be flush since the hood must align with both. If necessary to favor one fit over another, favor the vent grille for best appearance.

Lower the hood gently to down position and check for squareness of the fender set. The hood should have parallel split lines with the fender, and the noses of fenders and hood in line. If not in line, the sheet metal must be shifted sideways in the direction of the short fender until they do line up. If only one fender has been loosened and much movement is necessary, the other fender must be loosened the same as the fender being reset; that is, all attachment except directly behind the hood hinge. The final position, if correct, will produce parallel hood to fender lines and a flush condition at the nose of hood and fenders. (See Figure 110-15 for causes of long and short fenders.)

2. If the fender has good alignment to upper portion of door, open door and stuff shim between the fender tab and body door hinge pillar. If fender does not align up and down, pressure in the right direction should be exerted before

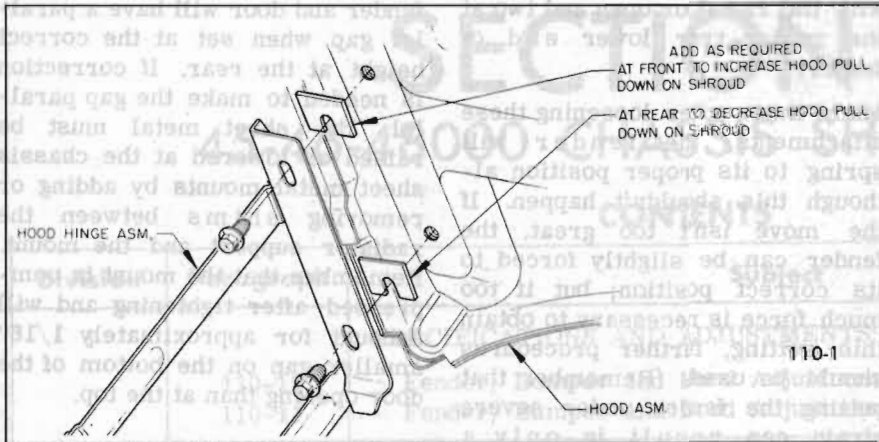

Figure 110-14—Shimming Hood Hinge to Hood

tightening the hinge pillar attachment. Slight correction to door can be made by over or under shimming (in and out) and forcing fender up or down without affecting the alignment to cowl vent in item #1. The fender to front of dash should now be secured and stuff shimmed if the gap exceeds 1/4 inch. The attachment at the rocker is last with shims stuffed between body and fender at the two bolt location so as not to affect the fender set when bolts are tightened.

3. The fender can be fattened or flattened to the door contour by either over or under shimming at the rocker panel attachment and forcing the fender up to fatten or down to flatten. This will only handle a small amount of contour change, however, but it is in a direction desired. When doing so, you should use the rear bolt location to work with and then stuff shim and tighten the front location. The parallel door to fender gap can be improved at this time, but too much fore or aft forcing will cause the fender to flare in or out at the bottom of the wheel cut.

4. All remaining bolts may now be tightened in any sequence.

If both fenders have been loosened, the other side should be attached using the same procedure.

b. Bumper Adjustment

The bumper attaching bolt holes in the frame and the back bars are slotted to permit movement of the bumper and permit proper alignment with adjacent parts.

c. Hood Adjustment

1. Hood set: First, the hood must have a square opening to make a commercial job. Lower the hood gently to down position and determine the correct move to make fore and aft at the hood hinge to hood attachment. This is done by simply assuming the hinges aren't even there; that is, if the hood hangs forward on one side and back on the other, the hood is moved on the hinge to correct the misalignment at the nose. The parallel lines will fall in by themselves if the sheet metal is square. To align hood in an out-of-square opening, take a little out-of-parallel of the split lines and some misalignment at the nose. When the hood is moved fore or aft, on either side, it affects the hood and fender gap on all four corners of the hood. Therefore, don't make one move and spoil three others. The final adjusting is done by the hinge pillar attachment. Try for parallel lines but as a last resort you can spoon one fender outboard and the opposite inboard and pick up enough gap in the hood line to make a good job out of a poor one.

The hood is flushed to the fender at the front by adjustable bumpers on the upper tie bar. Loosen the cam locking nut by rotating the clip on the top of the nut approximately 1/8 turn counterclockwise using a 3/4" wrench. Realign bumpers and after adjustment is satisfactory tighten locking nut by rotating clip clockwise 1/8 turn. Do not over tighten. It is only necessary to rotate the clip against toe tab stops on the nut. Be sure you close the hood like a gas station attendant, since the bumper compression depends on how hard the hood is closed. The rear of the hood is not supposed to have adjustment, but in some cases it may be necessary. If necessary to raise or lower at rear, loosen the three hood hinge attachments to fender. To raise the rear hood, loosen and tighten without supporting the hood; to lower the hood, raise the nose of the hood to remove any slack in attachment of hinge to fender and tighten the hinge in this position. If additional raising or lowering is necessary, shim between the hinge and hood at the front of the hood hinge attachment to lower or at the rear to raise. See Figure 110-14. The hinge hood works through the front hinge arm to pull the rear down so when you add a shim at the front hinge to hood attachment the front link travels farther which in turn makes the rear travel farther.

2. Hood Alignment: Move hood to right or left at front by hinge adjustment. Do not depend on hood latch. There is no adjustment in any direction in the hood latch assembly. If latch should need side to side adjustment, drive with hammer at the base of the latch. Extreme care must be taken not to injure the mechanism. Always check the safety catch by use of the release lever to insure absolutely no binding. The latch itself can be checked by closing the hood. Make this hammering operation only when necessary and as a last resort.

DIVISION II DESCRIPTION AND OPERATION

110-12 DESCRIPTION OF CHASSIS SHEET METAL

a. Chassis Sheet Metal Assembly

The chassis sheet metal assembly is attached to the frame and body at adjustment points. See Figure 110-17, 110-18 and 110-19. The front of the assembly is supported by two mounts located at the frame side rails. Shims at these locations allow up and down movement of the front of the sheet metal assembly. Fore and aft and side adjustment is allowed by oversize holes at the fender rear attaching points and chassis sheet metal mounts. Special shims at the rear locations allow adjustment of the rear of the assembly. The lower rear edge of the assembly is attached to the body at the rocker panel by bolts on each side. Shims are used at this location to provide up and down adjustment at the rear of the fender.

IMPORTANT: The bolts that retain the sheet metal braces must be torqued to the required torques. If these bolts are loose, the braces will not provide additional support for the sheet metal assembly.

b. Hood, Hinges and Latch Mechanism

The hood panel is of one piece construction, strengthened and held to shape by a reinforcement of stamped sheet metal.

The rear of the hood assembly is attached to the body cowl and fender on each side by hinge assemblies which permit the front of the hood to be raised. A heavy coil spring connected between each hinge assembly assists in raising the hood and holds it in the open position. See Figures 110-22 and 110-23.

The front of the hood is held down by a ratchet type hood latch mounted on the center grille support and radiator support. See Figure 110-24.

DIVISION III SERVICE PROCEDURES

110-13 REMOVAL AND INSTALLATION OF HOOD ASSEMBLY

1. Support hood in extreme "up" position.
2. Place folded rags under rear corners of hood to prevent possible damage to fenders.
3. Scribe a reference line along edge of each hinge flange so hood can be replaced in same position.
4. Remove two hood hinge to hood bolts from each side.
5. Lift hood from car.
6. To install, reverse above procedure.

110-14 REMOVAL AND INSTALLATION OF HOOD HINGE SPRING

1. To remove hood hinge spring, insert Remover and Installer J-9214 through loop in forward end of spring with bend of tool approximately one inch from loop. Using inside corner formed by hinge as a pivot, unseat spring from notch. See Figure 110-23.
2. Then push tool forward, causing hood spring to slide clear of hinge.
3. To replace hood spring, insert Remover and Installer J-9214 through loop in forward end of spring. Using hinge as a pivot, seat spring into notch.

110-15 REMOVAL AND INSTALLATION OF HOOD HINGE

a. Removal

1. Prop the hood in the extreme

"up" position and place folded rags under rear corners of hood to prevent possible damage to fenders.

2. Scribe position of the hood hinge on the hood and remove two hood hinge to hood bolts.
3. Scribe position of the hinge attachment on fender. Remove the three bolts attaching the hinge to the fender and remove the hinge. See Figure 110-22.

b. Installation

1. Align hood hinge with scribe marks on fender and install three bolts attaching the hinge to the fender. Do not tighten.
2. Align hood hinge with scribe mark on hood and install two bolts attaching hood hinge to hood. Do not tighten.
3. Close hood and align flush with cowl and fenders.
4. Raise hood and tighten all mounting bolts to 15 lb. ft.
5. Remove all protective coverings.

110-16 REMOVAL AND INSTALLATION OF FENDER AND SKIRT

1. Disconnect battery cables and remove battery if battery is on same side as fender being removed.
2. Unfasten all electrical wires attached to fender skirt.
3. Remove four bolts securing battery base to support and fender skirt. Lift out battery base. See Figure 110-16 (View B).
4. Remove four bolts securing battery base reinforcement to skirt and radiator support.
5. Remove four bolts securing radiator support side reinforcement to radiator support, fender and skirt.

6. Remove three bolts securing outer end of radiator support to skirt and fender. See Figure 110-17 (View Q).

7. Remove three bolts securing front of fender to radiator support.

8. Remove three screws securing fender lower front baffle to frame. See Figure 110-19 (View N).

9. Remove three hood hinge to fender bolts supporting hood as outlined in paragraph 110-15.

10. Remove two bolts securing skirt to lower portion of cowl. See Figure 110-19 (View L).

11. Remove two bolts securing lower rear edge of fender to rocker panel. See Figure 110-18 (View J).

12. Remove one bolt securing upper rear portion of fender to hinge pillar. See Figure 110-18 (View K).

13. Remove two bolts securing upper rear portion of fender to upper portion of cowl. See Figure 110-18 (View H).

14. Disconnect antenna lead (if so equipped).

15. Remove two bolts securing fender to upper tie bar. See Figure 110-16 (View D).

16. Raise up and lift off fender and skirt.

17. Skirt can now be removed from fender by removing skirt to fender attaching bolts. See Figure 110-16.

18. To install, reverse above procedure attaching at points marked "Net" first.

clearance should exist or by worn or dry hood bumpers.

If the hood squeaks, check for uniform clearance all around the hood, fenders and cowl. If an edge of metal is making contact at any point where clearance should exist, a bright metal spot will usually be found. Such spots may be depressed by spring hammering to provide clearance.

A grunting noise in the hood is usually caused by dry rubber bumpers or cowl ledge lacing. Lubricate all rubber bumpers on fender rails and cowl with silicone rubber lubricant. To correct a persistent case of squeaking or grunting where hood top panel contacts ledge lacing, even when lubricated, cement a 1/16" thick strip of felt to panel where the lacing makes contact.

To prevent hood panel flutter, the rear end of the hood panel must have firm contact with the rubber bumpers and lacing attached to cowl ledge. The hood may be raised or lowered by adjustment at hinges. See paragraph 110-11, subparagraph c-3.

**DIVISION IV
TROUBLE
DIAGNOSIS**

110-17 HOOD NOISES OR PANEL FLUTTER

Squeaks or grunting noises in the hood when driving over rough roads do not necessarily indicate misalignment of hood or fenders. These noises may be caused by metal contact at some point where

110-15 REMOVAL AND INSTALLATION OF HOOD AND SKIRT
1. Disconnect battery cables and remove battery if battery is on fender side as fender panel is removed.
2. Then push fender forward and up to clear hood.
3. Remove four bolts securing battery base to support and fender.
4. Remove four bolts securing battery base to support and fender.
5. Remove four bolts securing radiator support side reinforcement to radiator support and fender and skirt.

1. For removal hood latching mechanism, disconnect antenna lead and disconnect hood latch cable.
2. Then push fender forward and up to clear hood.
3. Remove four bolts securing battery base to support and fender.
4. Remove four bolts securing battery base to support and fender.
5. Remove four bolts securing radiator support side reinforcement to radiator support and fender and skirt.

1. For removal hood latching mechanism, disconnect antenna lead and disconnect hood latch cable.
2. Then push fender forward and up to clear hood.
3. Remove four bolts securing battery base to support and fender.
4. Remove four bolts securing battery base to support and fender.
5. Remove four bolts securing radiator support side reinforcement to radiator support and fender and skirt.

SKETCHES SHOWING CAUSES OF LONG AND SHORT FENDERS

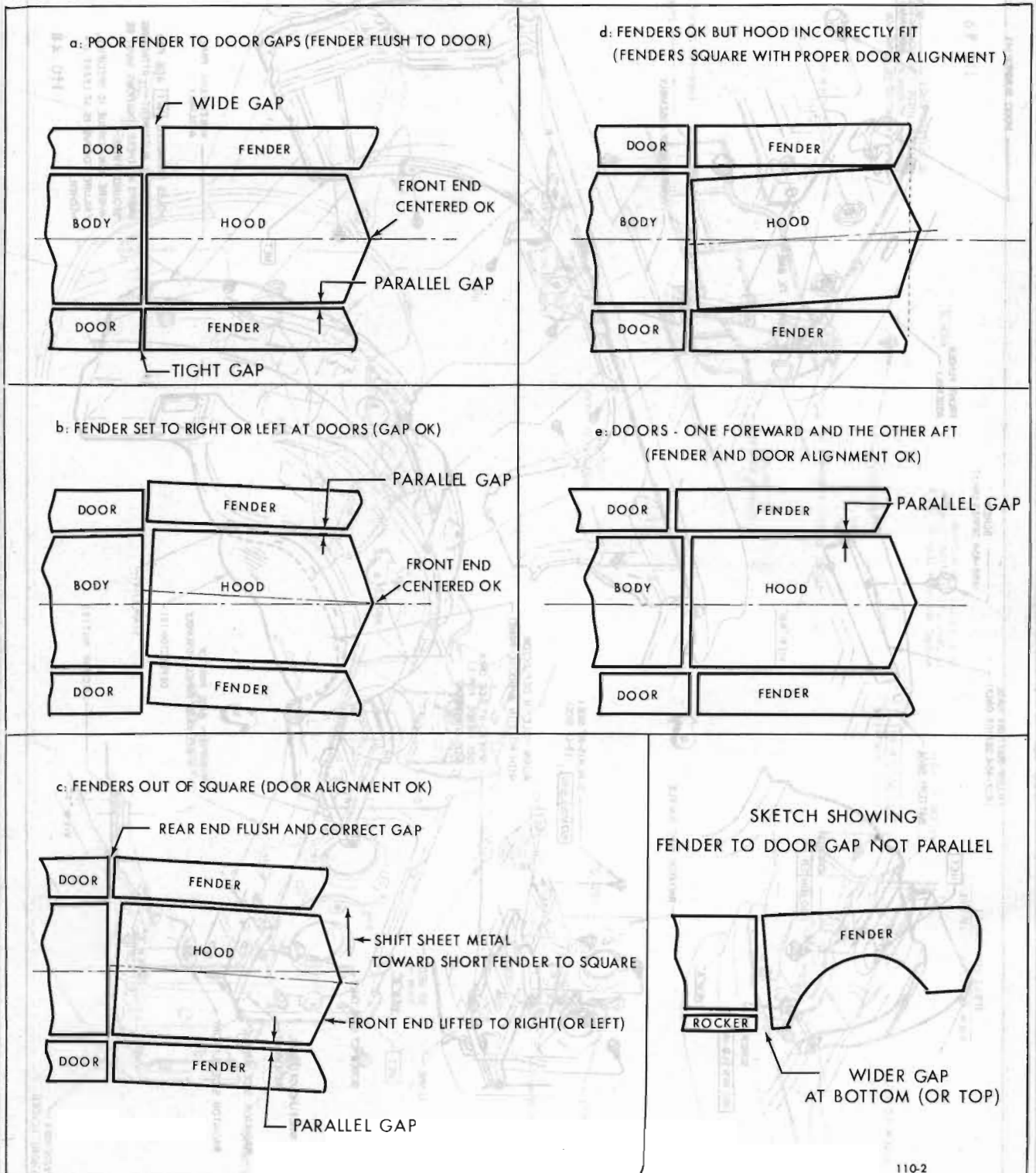

Figure 110-15—Chassis Sheet Metal Alignment

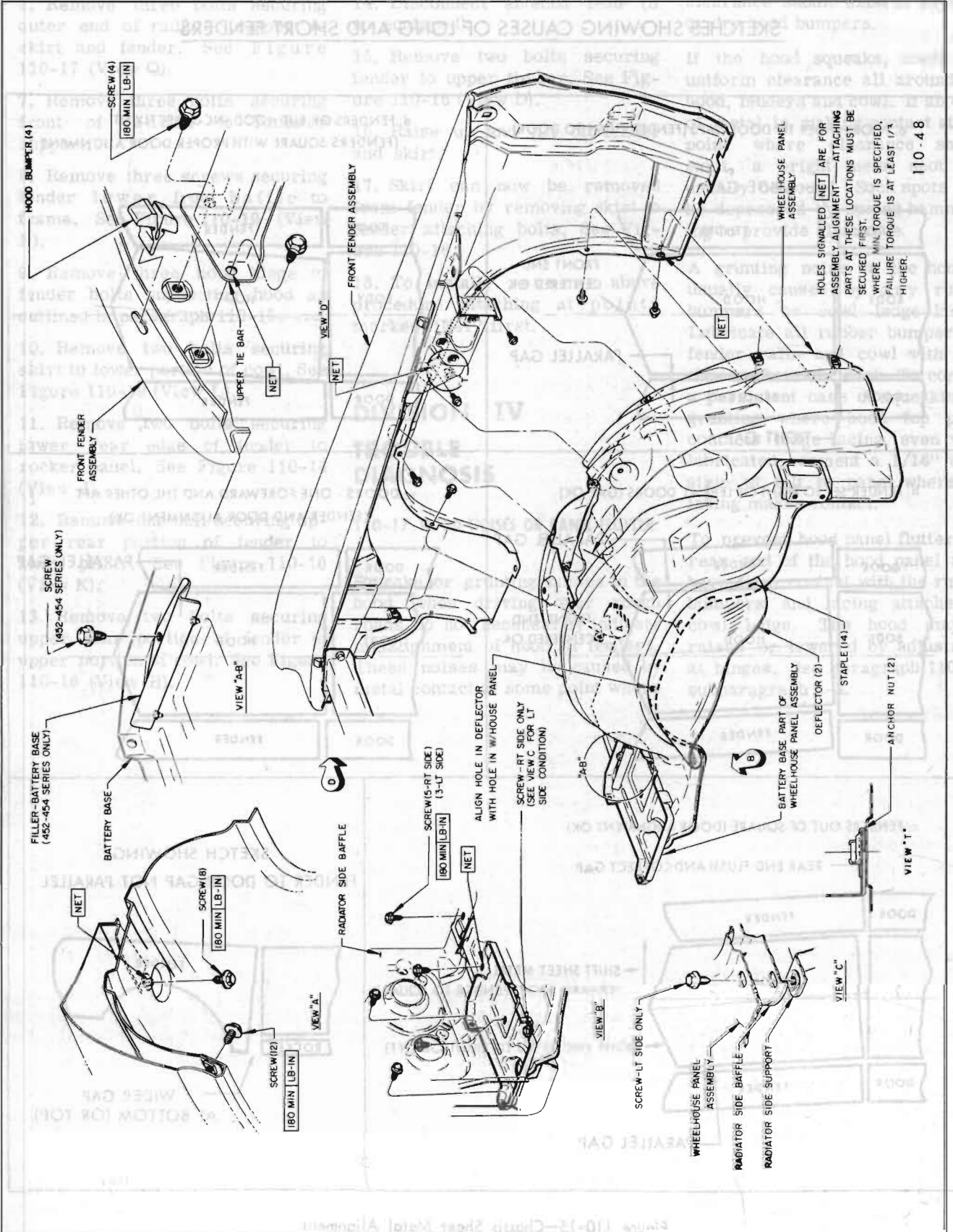

Figure 110-16 45-46-48000 Fender, Skirt, Battery Base

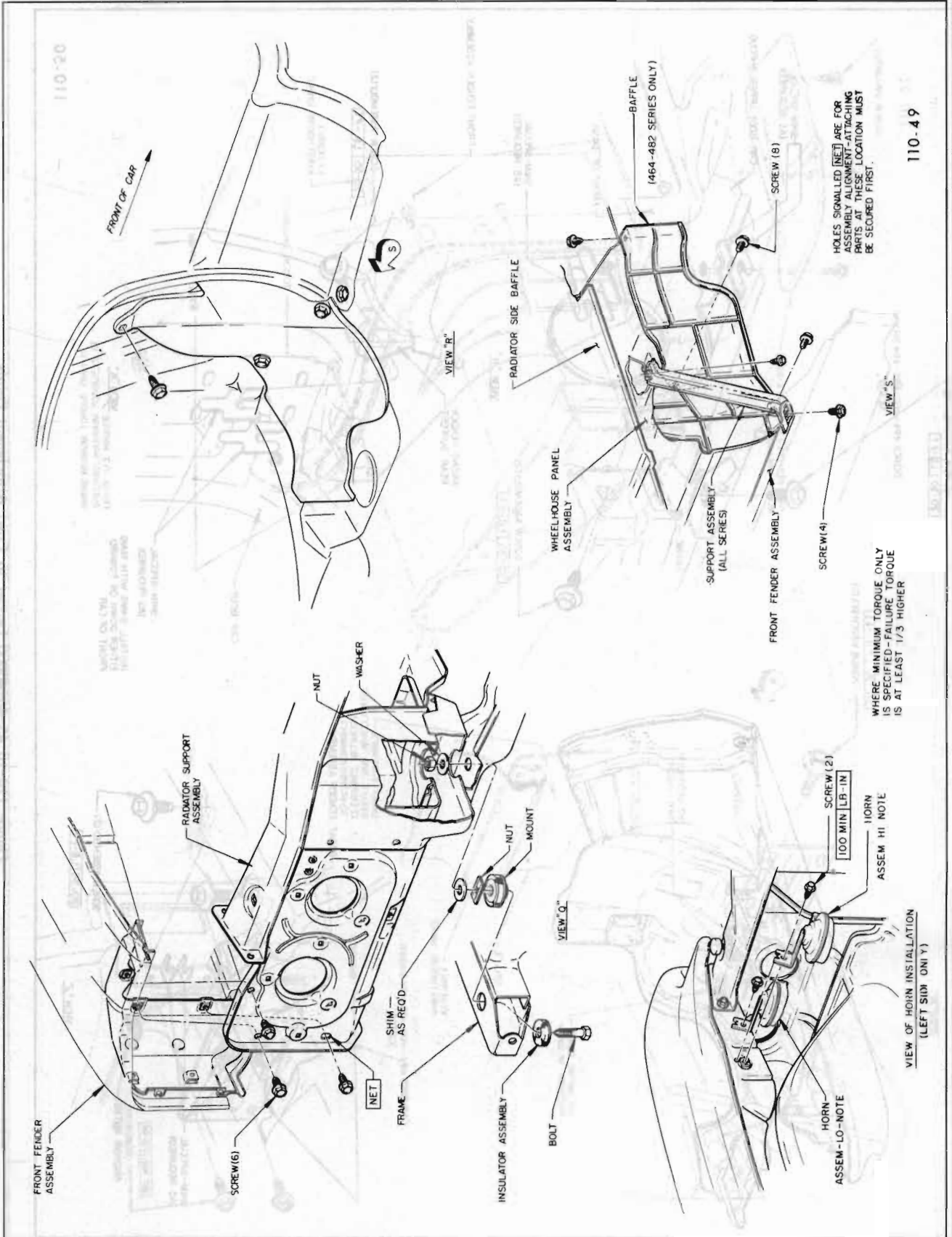
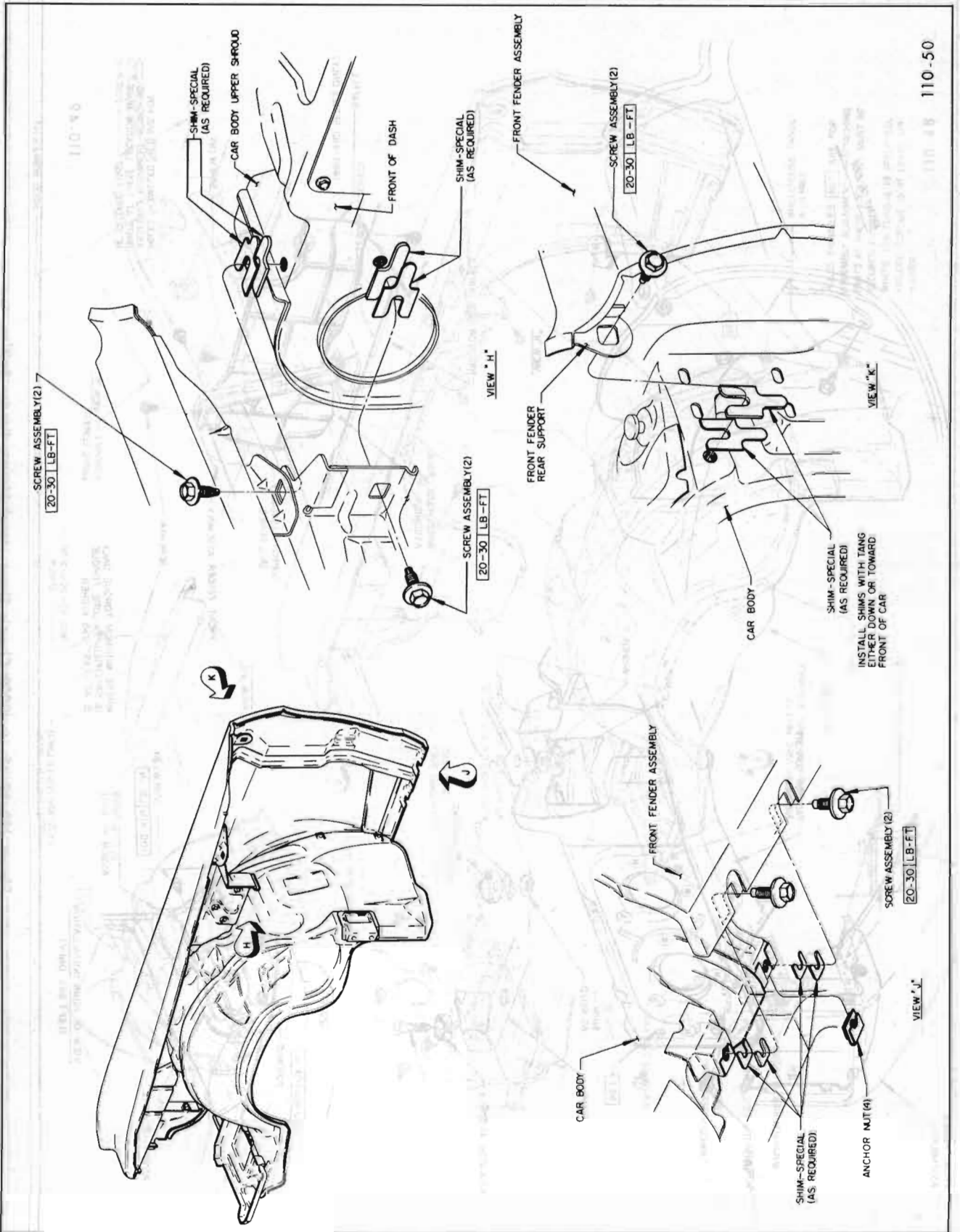

Figure 110-17 45-46-48000 Chassis Sheet Metal Mount, Fender Baffles



110-50

Figure 110-18 45-46-48000 Fender to Cowl Attachment Points

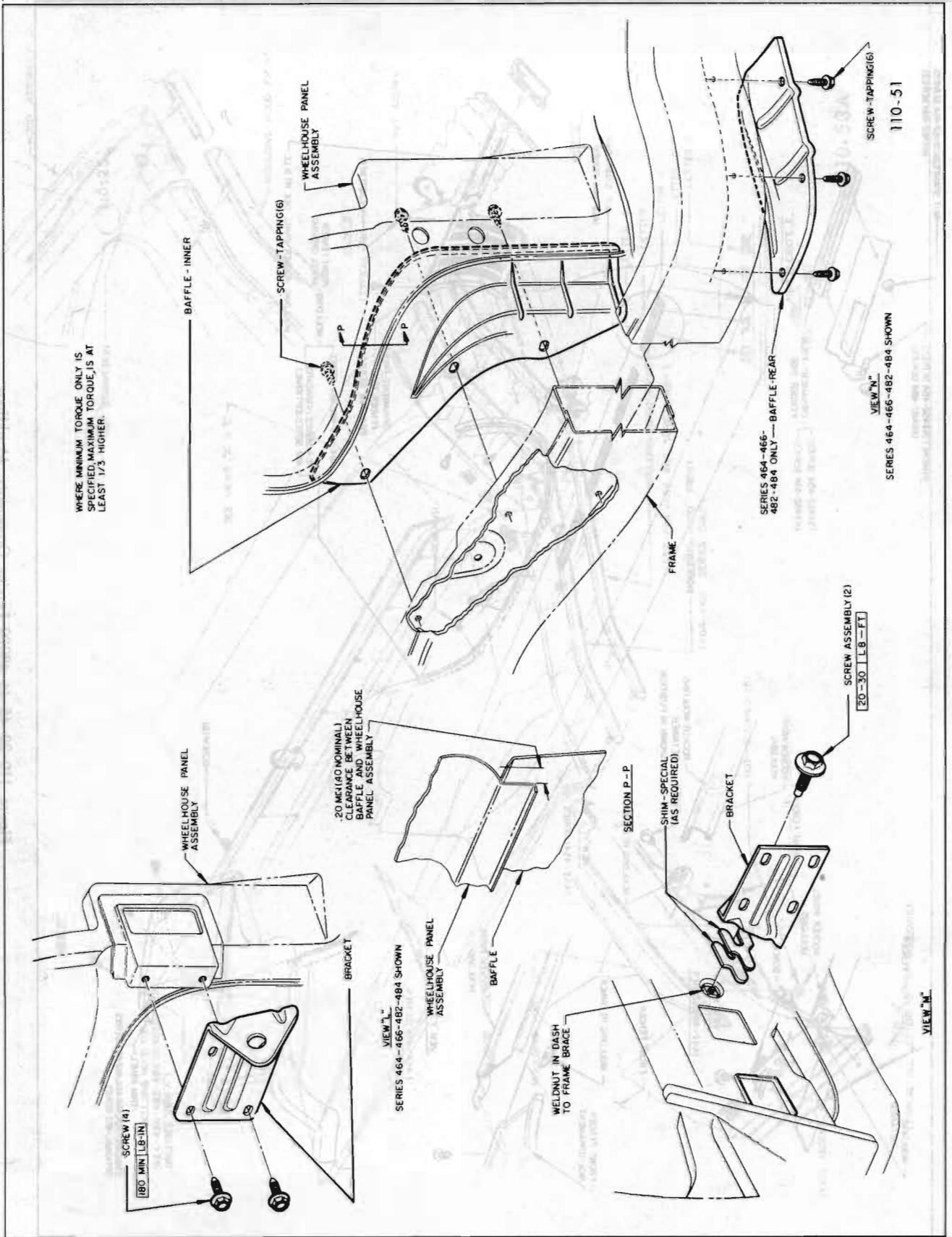

Figure 110-19 45-46-48000 Fender Baffles, Fender to Cowl Attachment Points

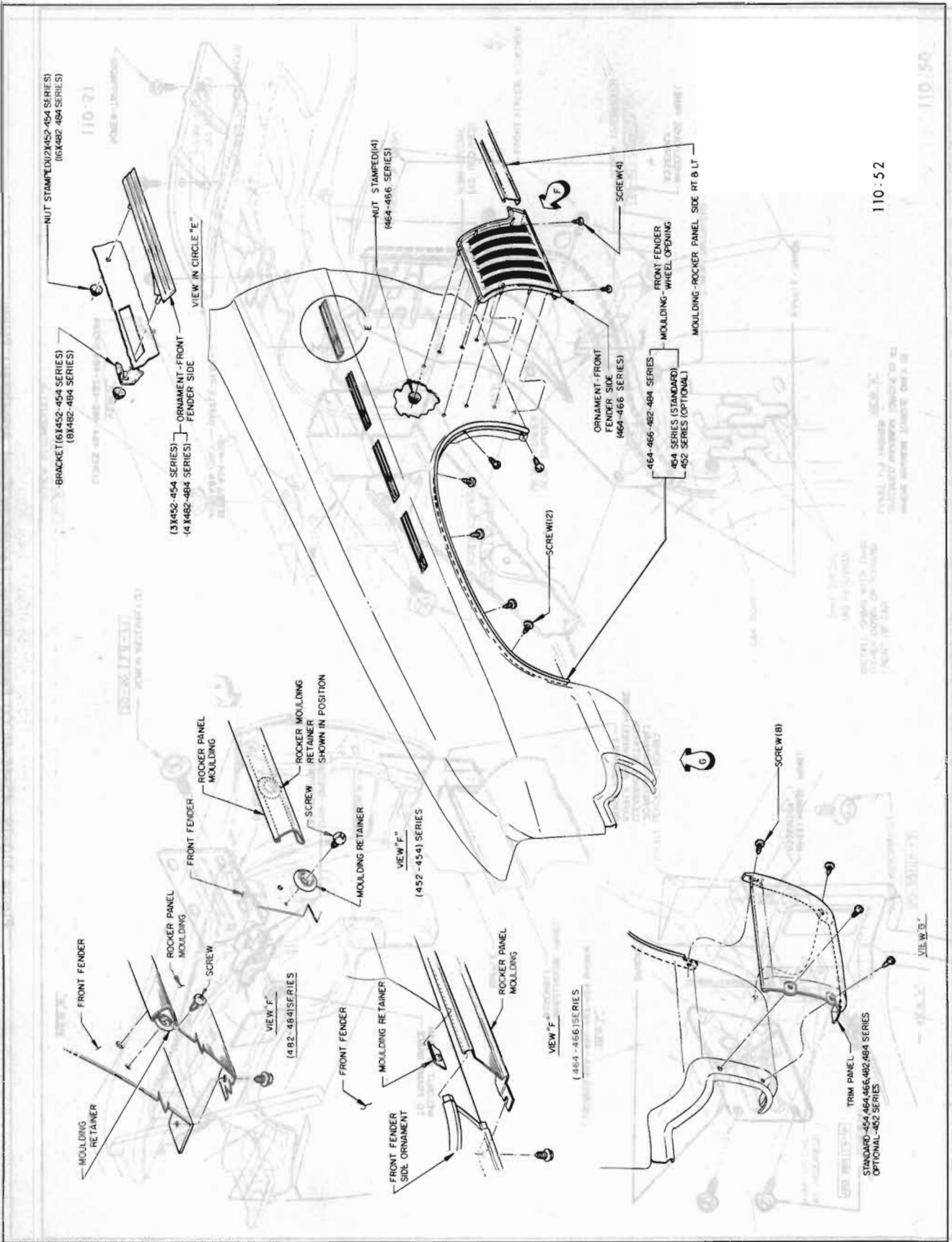

Figure 110-20 45-46-48000 Fender Ornaments, Mouldings

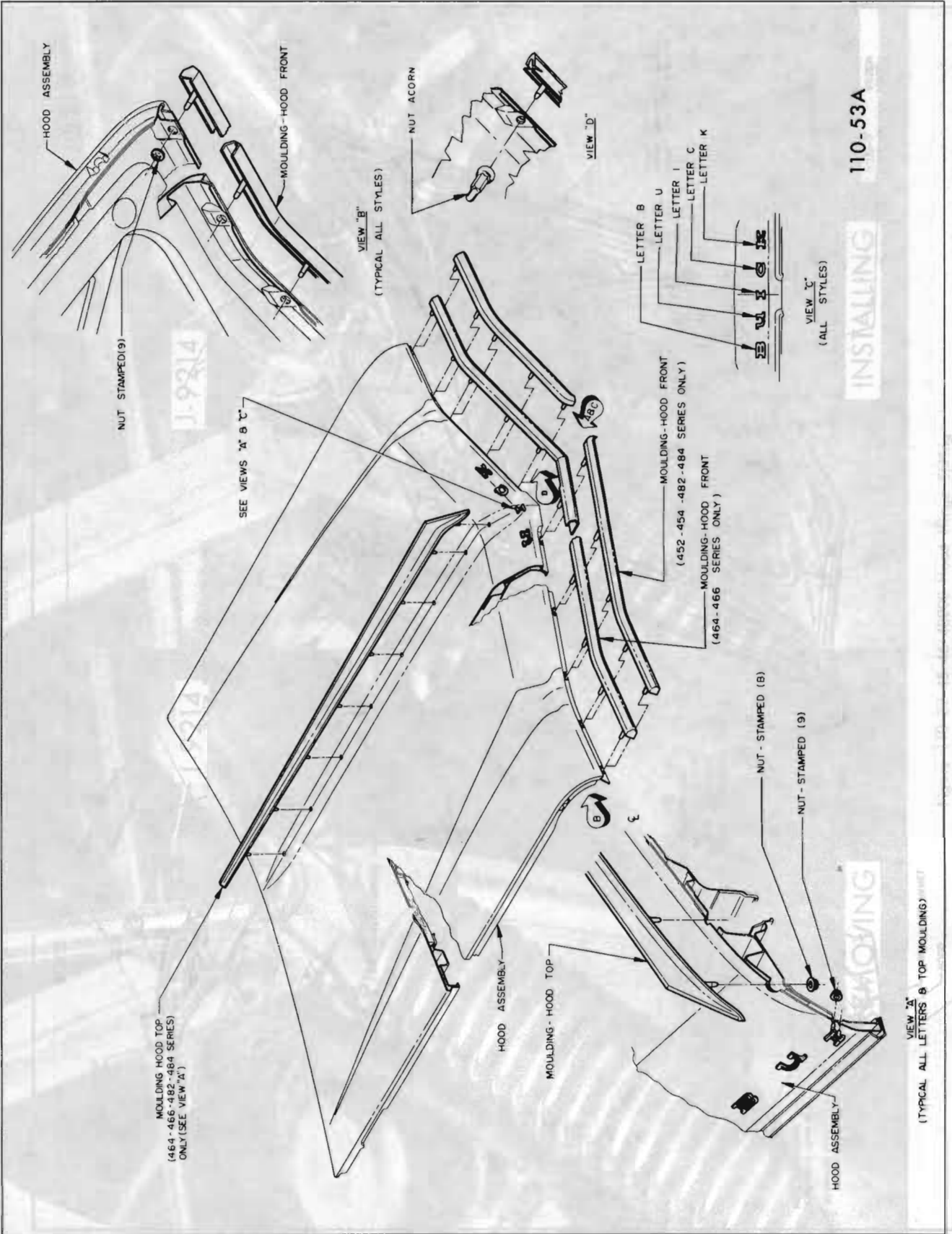

Figure 110-21 45-46-48000 Hood Mouldings

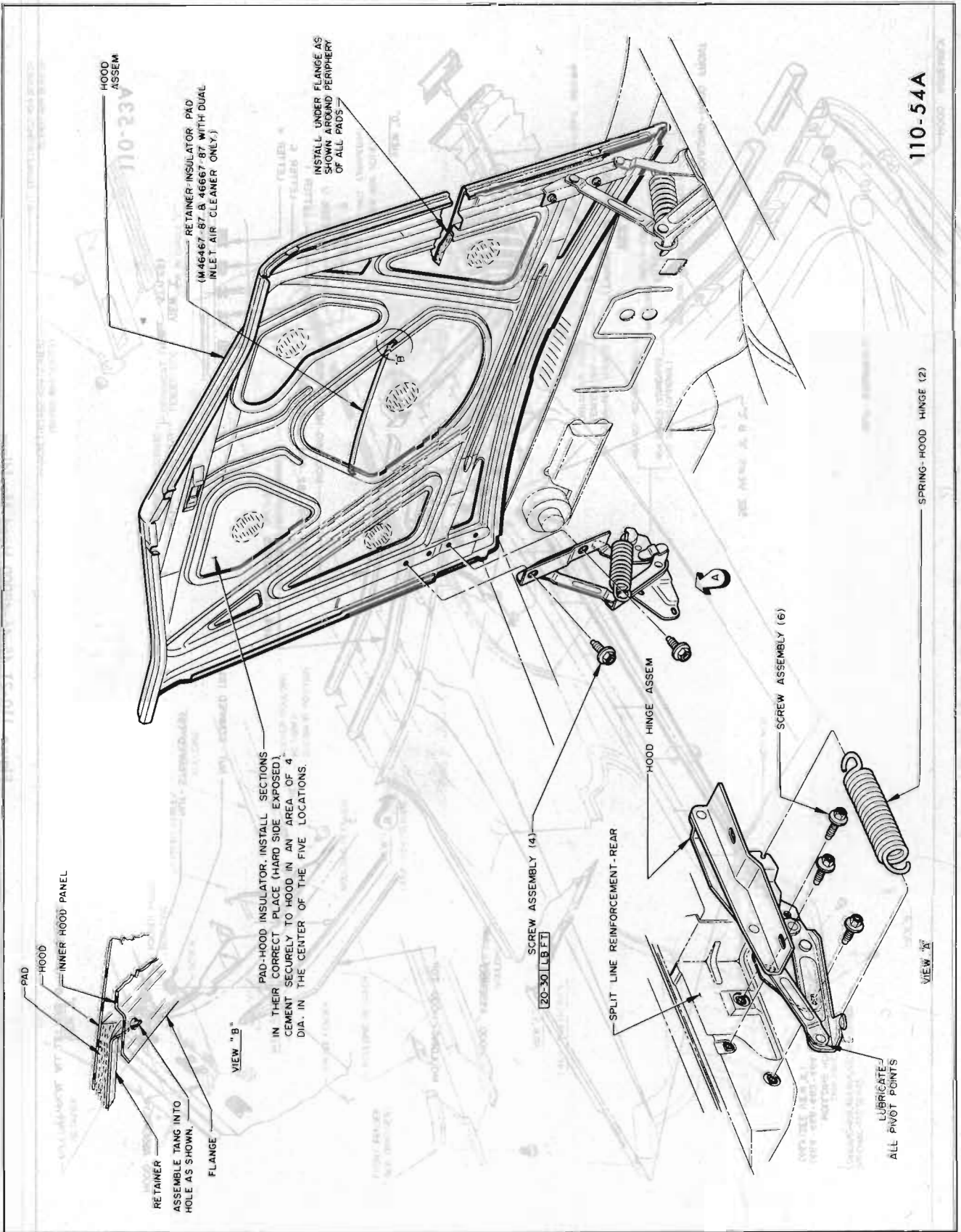

Figure 110-22 45-46-48000 Hood, Hood Hinge

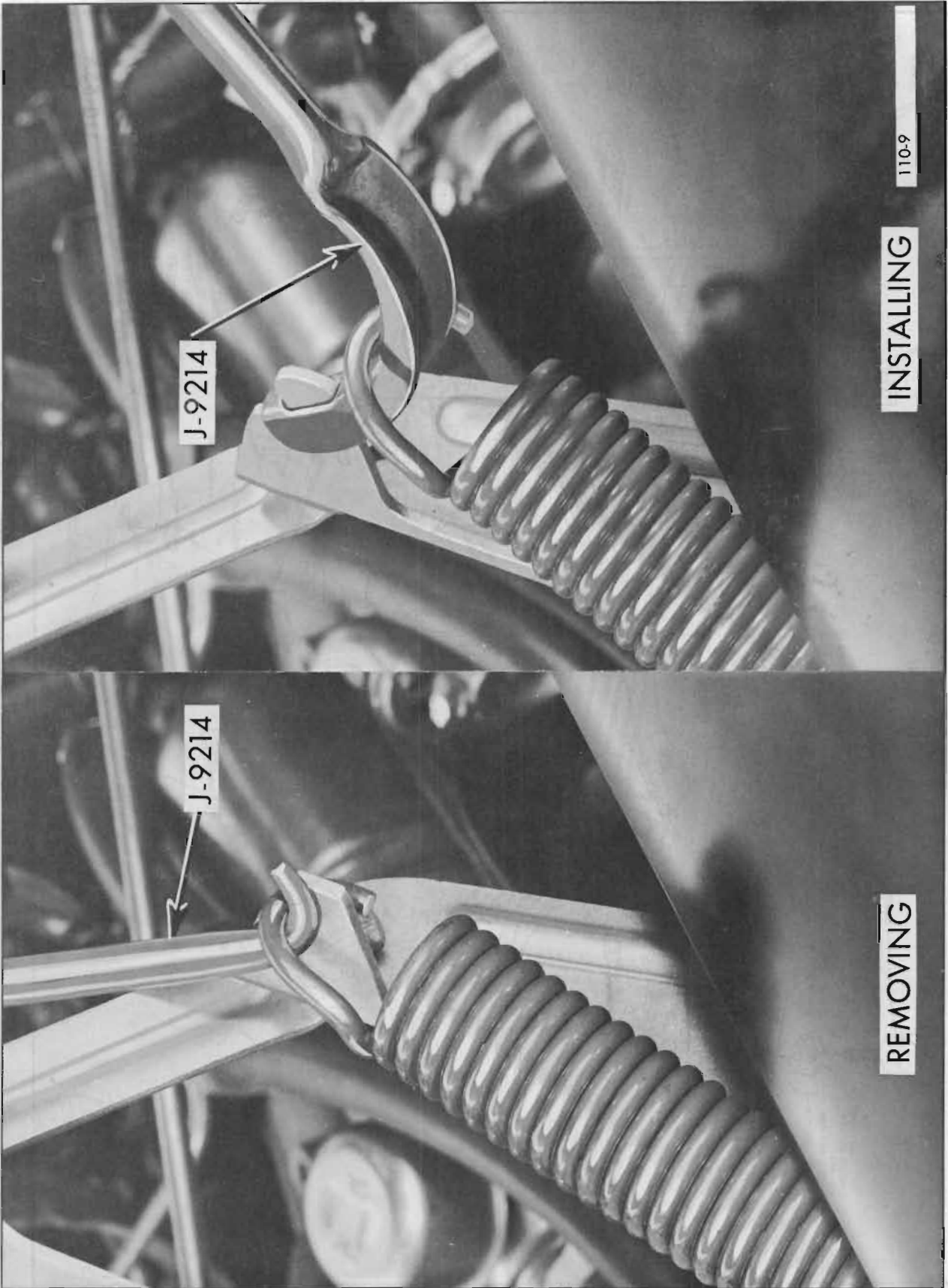

Figure 110-23 45-46-48000 Hood Hinge Spring

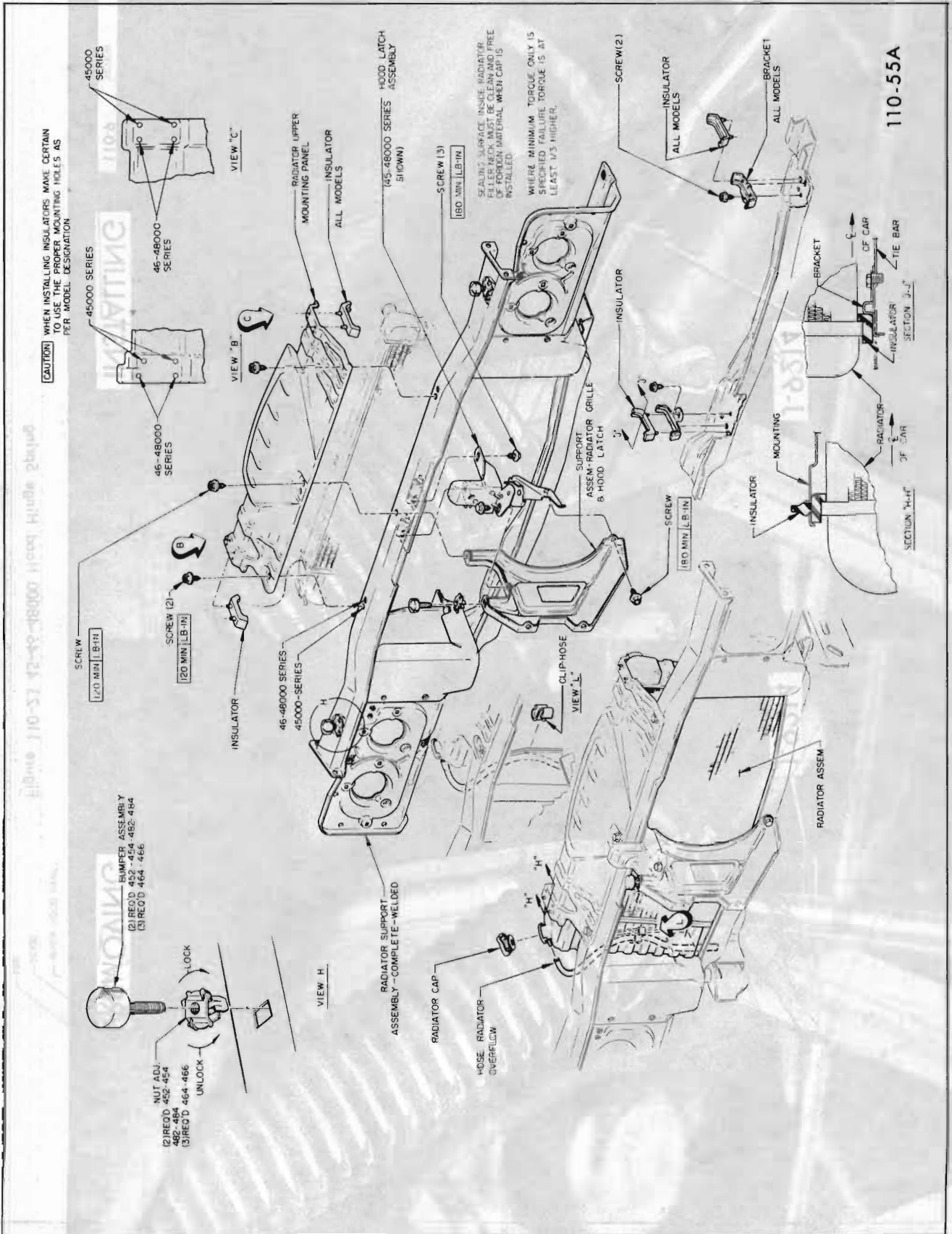

Figure 110-24 45-46-48000 Radiator Support, Hood Latch

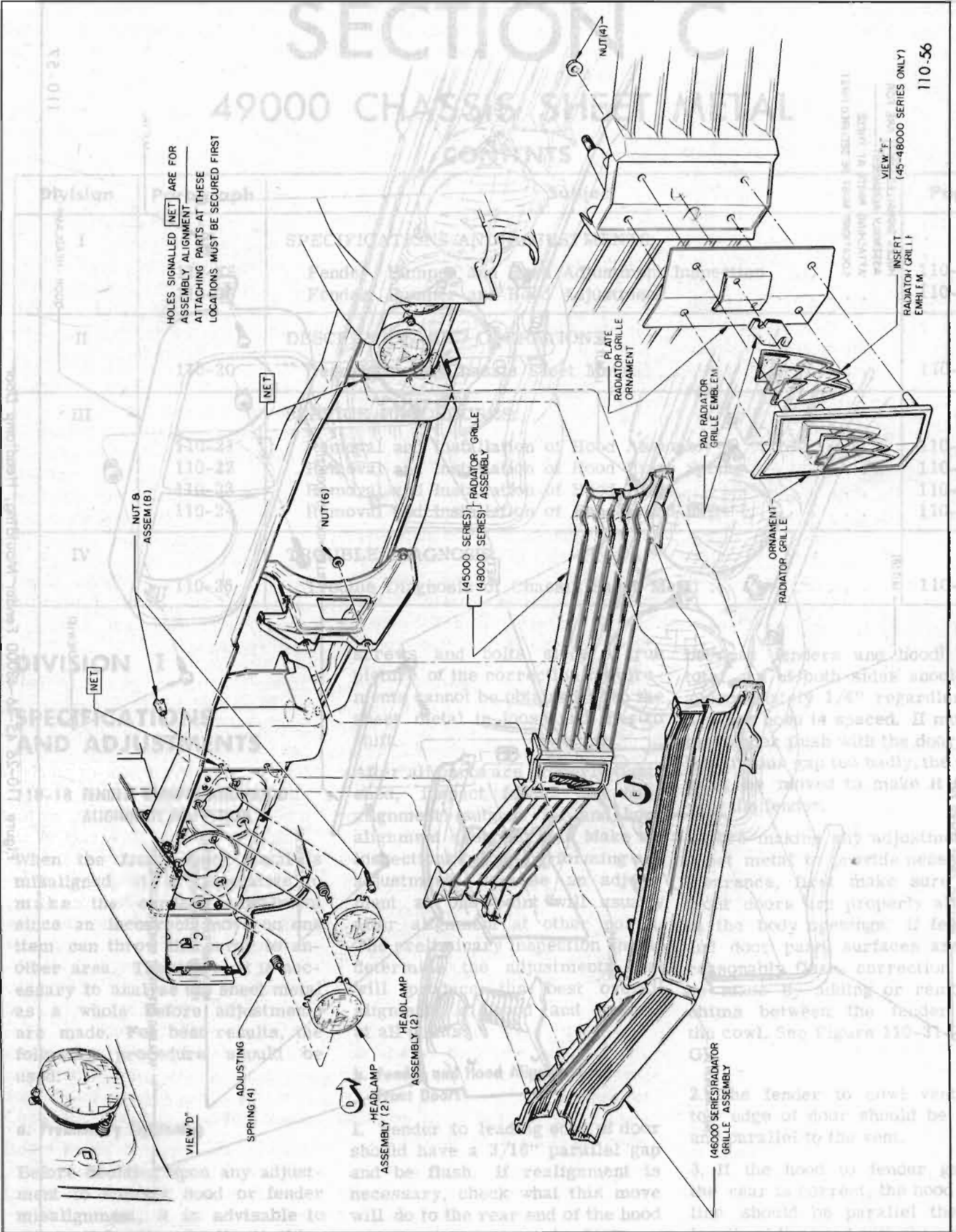

Figure 110-25 45-46-48000 Grille, Grille Ornament

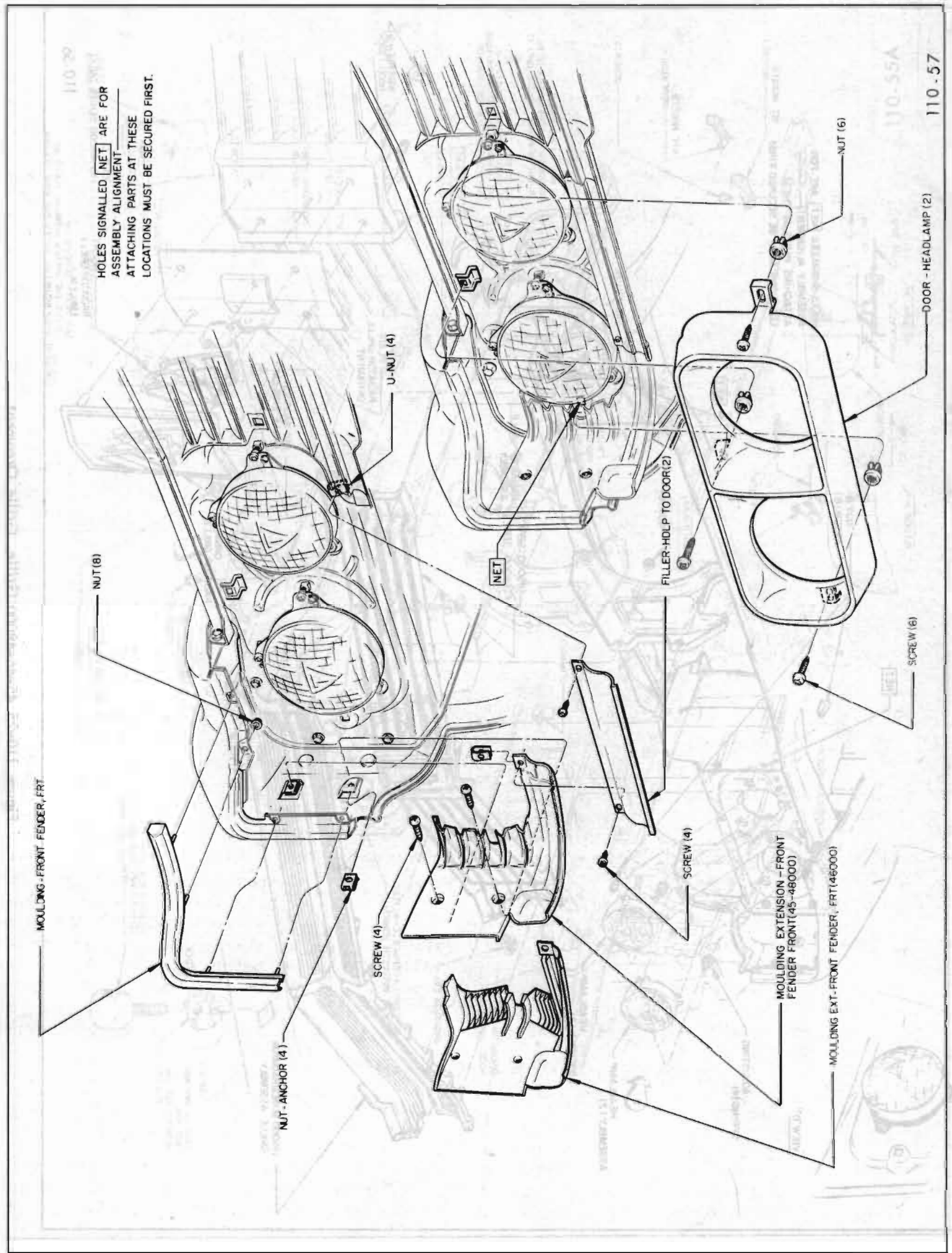

Figure 110-26 45-46-48000 Fender Moulding, Headlamp Door