

# SECTION 2 LUBRICATION

## INDEX

| Subject  | Page | Subject  | Page |
|--|------|--|------|
| Instrument Panel Compartment Door . . . . .                                      | 2-1  | Rear Quarter Window Regulator Cams and Guides.                   | 2-4  |
| Front Door Hinge Hold-Open Assembly . . . . .                                    | 2-1  | Rear Compartment Lid Lock . . . . .                              | 2-5  |
| Rear Door Hinge Hold-Open Assembly . . . . .                                     | 2-1  | Rear Compartment Hinges and Torque Rods . . . . .                | 2-5  |
| Door Lock Fork Bolt and Rotary Bolt . . . . .                                    | 2-1  | Tail Gate Window Regulator and Cams<br>(Station Wagon) . . . . . | 2-5  |
| Door Lock Striker . . . . .  | 2-1  | Tail Gate Lock Striker (Station Wagon) . . . . .                 | 2-5  |
| Door Jamb Switch . . . . .   | 2-2  | Tail Gate Hinges (Station Wagon) . . . . .                       | 2-5  |
| Door Lock Mechanism and Lock Parts . . . . .                                     | 2-2  | Gas Tank Filler Door Hinge . . . . .                             | 2-5  |
| Front Compartment Lid Lock . . . . .   | 2-2  | Folding Seat Linkage . . . . .                                   | 2-5  |
| Door Window Regulator and Cams - Styles<br>with Upper Frames . . . . .           | 2-2  | Front Seat Adjuster Mechanism . . . . .                          | 2-6  |
| Door Window Regulator Cams and Guides - Styles<br>without Upper Frames . . . . . | 2-2  | Convertible Top Linkage . . . . .                                | 2-6  |

### DESCRIPTION

The movable mechanical parts of the body are lubricated at the factory to insure proper and quiet operation. If additional lubrication is required, the following specified materials or their equivalents should be used at the locations listed.

### INSTRUMENT PANEL COMPARTMENT DOOR HINGE

Wipe off dirt and apply a sparing amount of driplless oil to the hinge frictional points. Operate door and wipe off excess lubricant.

### FRONT DOOR HINGE HOLD-OPEN ASSEMBLY

Wipe off dirt and apply engine oil to points indicated (Fig. 2-1).

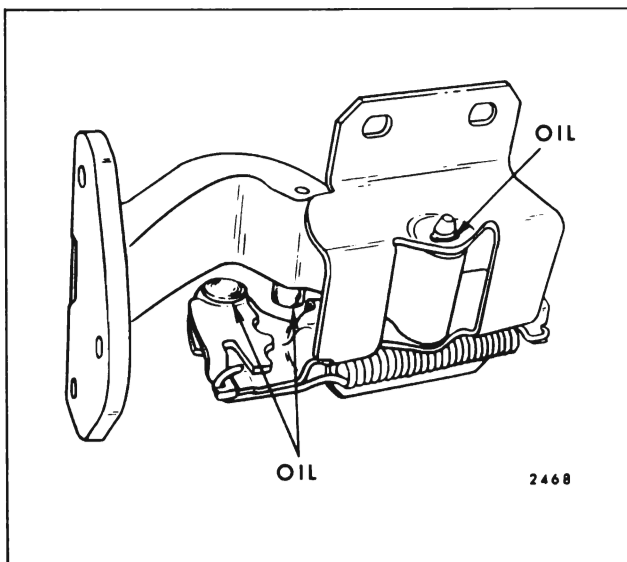

Fig. 2-1 — Front Door Hinge Hold-Open Assembly

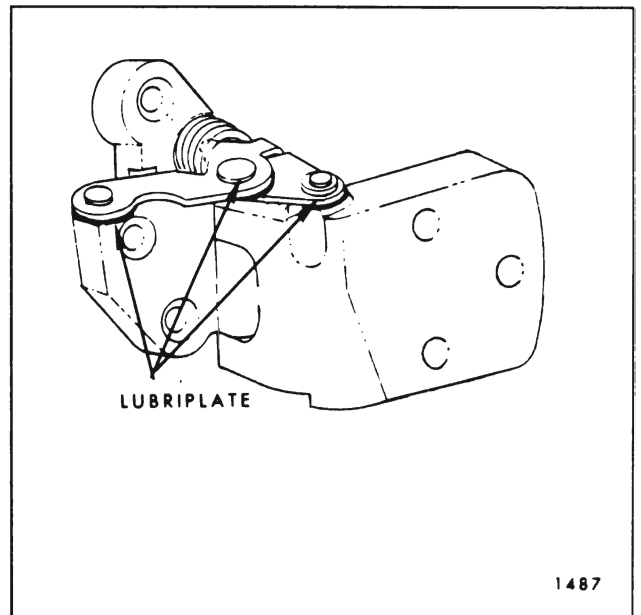

Fig. 2-2 — Rear Door Hinge Hold-Open Assembly

### REAR DOOR HINGE HOLD-OPEN ASSEMBLY

Wipe off dirt and apply a light coat of Lubriplate to frictional points (Fig. 2-2). Wipe off excess lubricant.

### DOOR LOCK FORK BOLT AND ROTARY BOLT

Wipe off dirt and apply a thin coat of stick-type lubricant and oil (Fig. 2-3 and 2-4).

### DOOR LOCK STRIKER

Wipe off dirt and apply a thin coat of stick-type lubricant to top surface of striker teeth at areas indicated (Fig. 2-5).

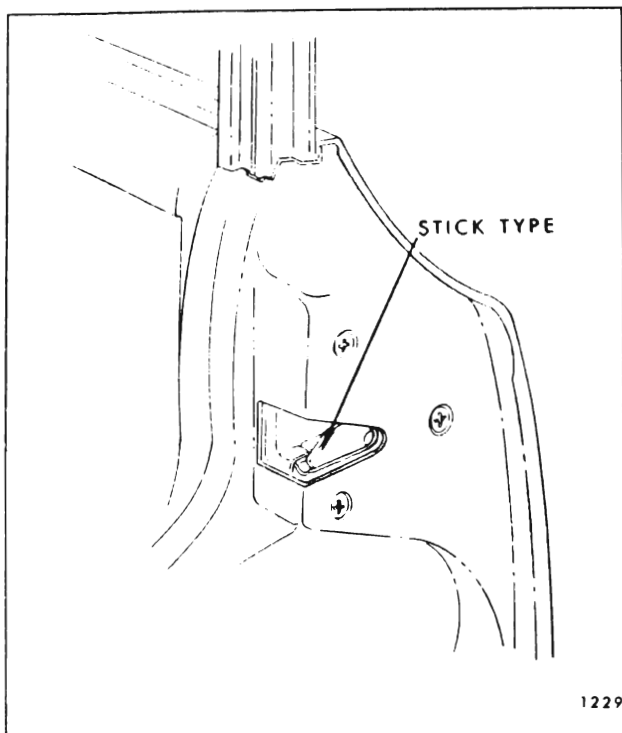

Fig. 2-3 — Door Lock Fork Bolt and Rotary Bolt

end surface of switch plunger and remove excess lubricant.

**DOOR LOCKING MECHANISM AND LOCK PARTS**

Apply Lubriplate to pivot points at ends of connecting rods and moving parts of lock.

**FRONT COMPARTMENT LID LOCK**

On front compartment lid lock apply a thin coat of Lubriplate to contact point as indicated (Fig. 2-6).

**DOOR WINDOW REGULATOR AND CAMS—STYLES WITH UPPER FRAMES**

Apply a coat of Lubriplate to areas indicated, (Fig. 2-7). Lubrication of front and rear doors with upper frames is typical.

**DOOR WINDOW REGULATOR CAMS AND GUIDES—STYLES WITHOUT UPPER FRAMES**

Apply a coat of Lubriplate to areas indicated. (Fig. 2-8). Lubrication of front and rear doors without upper frames is typical.

**DOOR JAMB SWITCH**

Wipe off dirt and apply a thin coat of Lubriplate to

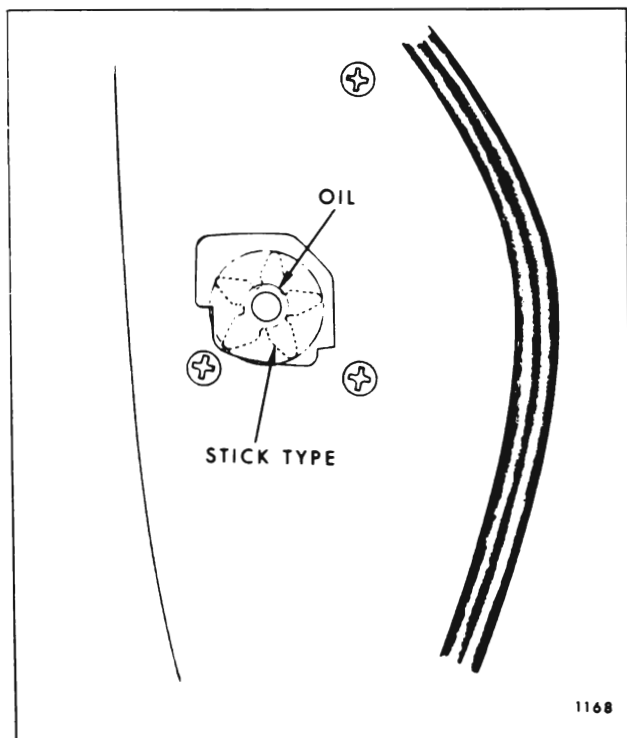

Fig. 2-4 — Door Lock Fork Bolt and Rotary Bolt

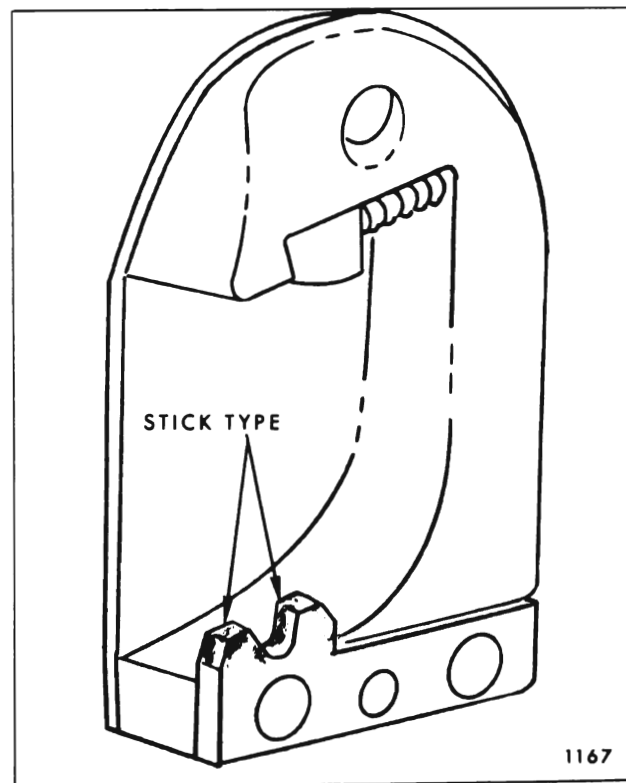

Fig. 2-5 — Door Lock Striker

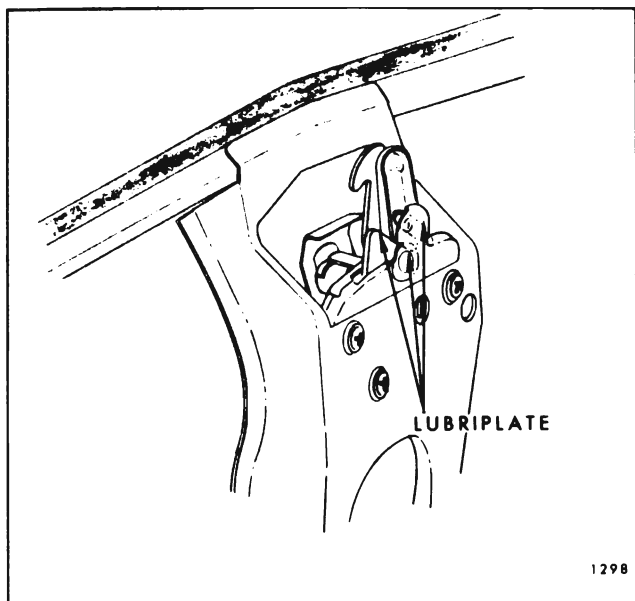

Fig. 2-6 — Front Compartment Lid Lock

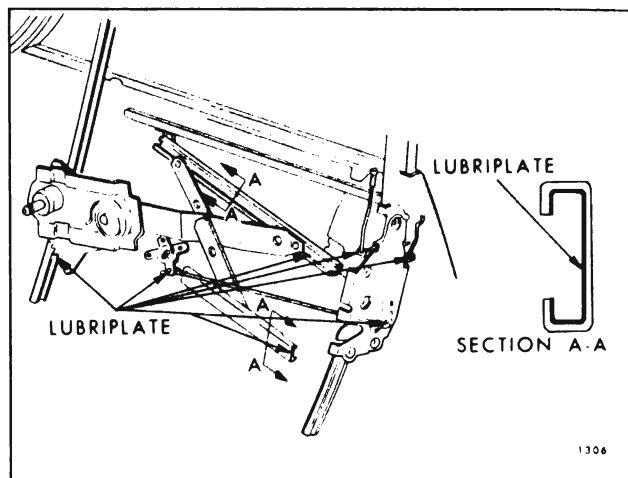

Fig. 2-7 — Door Window Regulator and Cams On Styles With Upper Frames

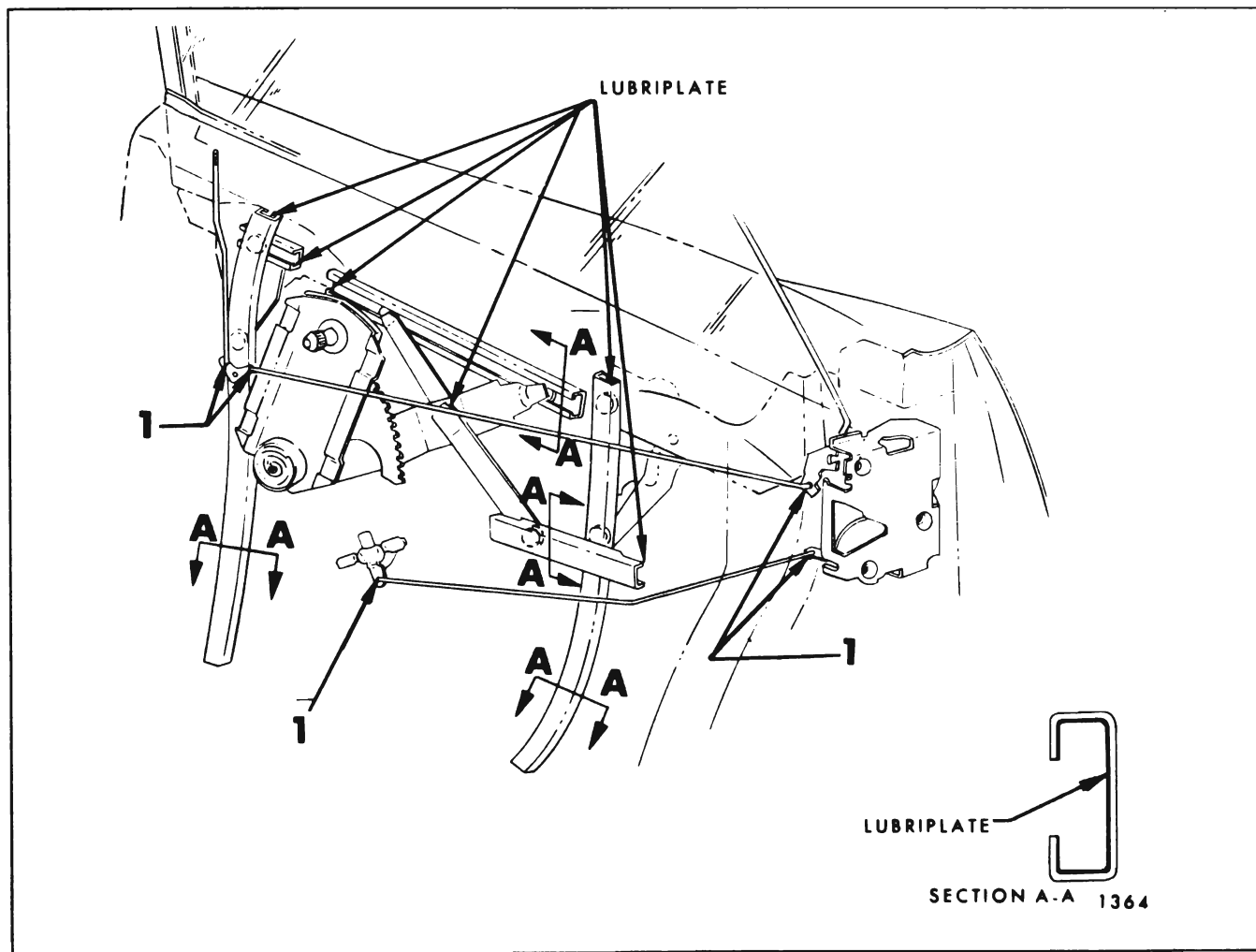

Fig. 2-8 — Door Window Regulator and Cams On Styles Without Upper Frames

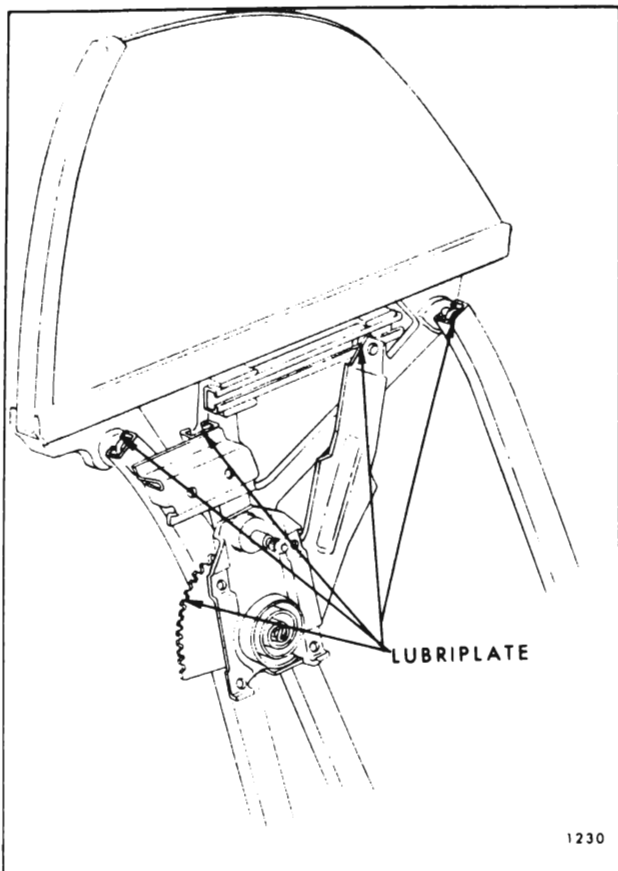

Fig. 2-9—Rear Quarter Window Regulator Cams and Guides

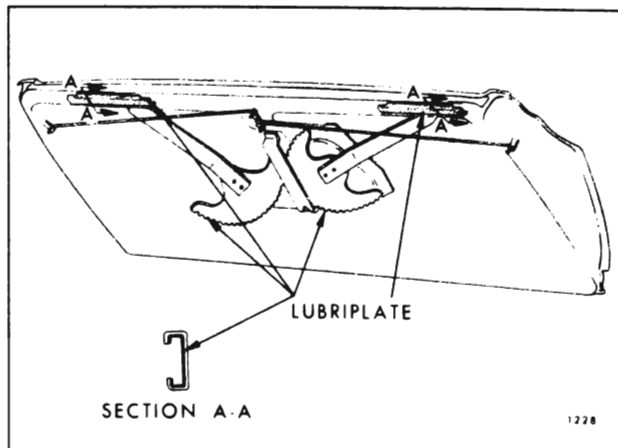

Fig. 2-11—Tail Gate Window Regulator and Cams (Station Wagons)

### REAR QUARTER WINDOW REGULATOR CAMS AND GUIDES

Apply a coat of Lubriplate to regulator, cams and guides. Lubrication shown is typical of points to be lubricated on other quarter window regulators, etc. (Fig. 2-9).

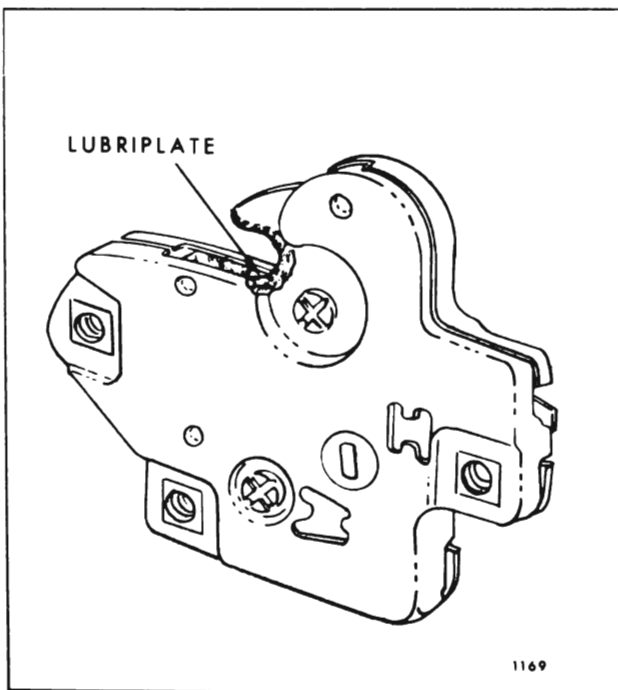

Fig. 2-10—Rear Compartment Lid Lock

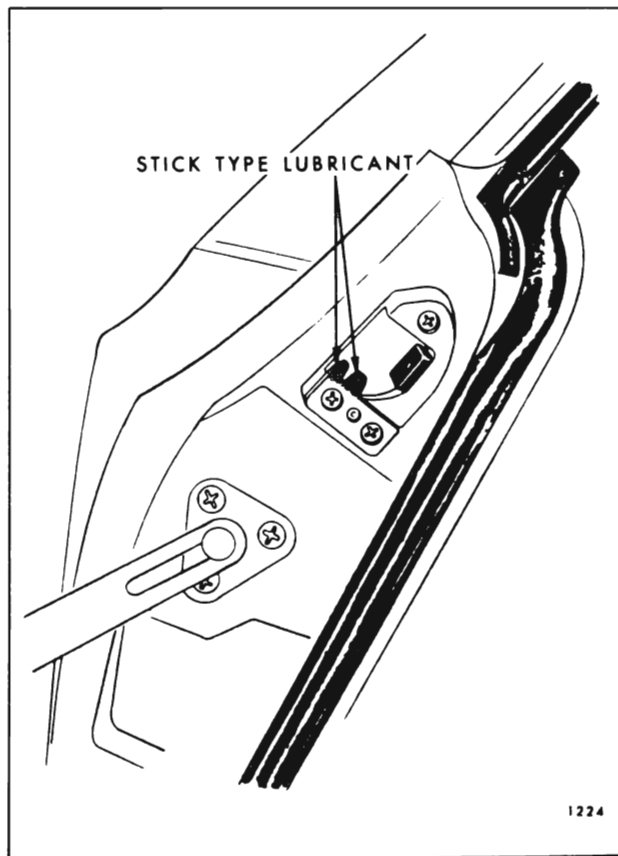

Fig. 2-12—Tail Gate Lock Striker Station Wagon

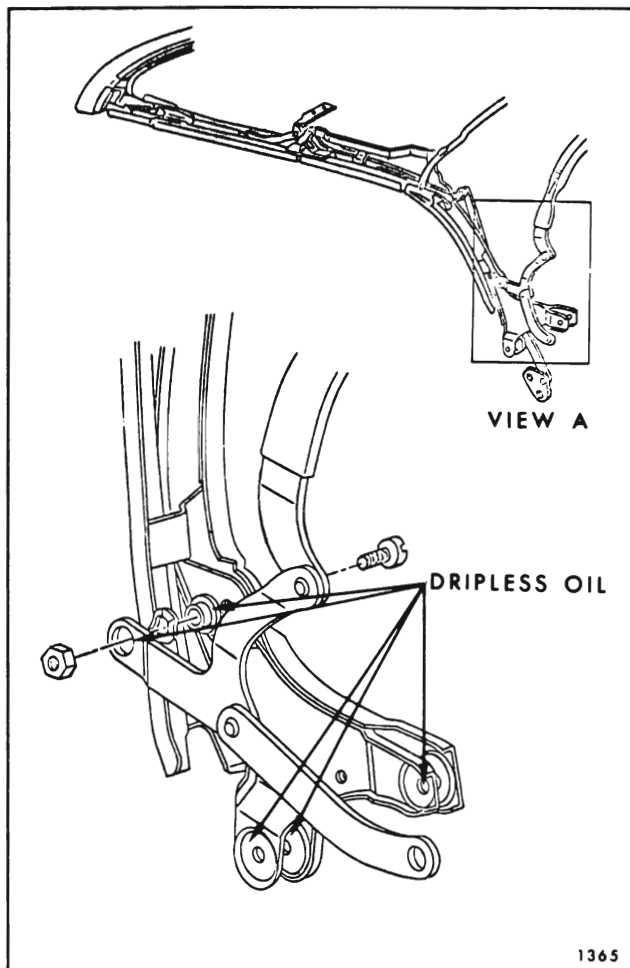

Fig. 2-13 — Convertible Top Linkage - "B and C" Styles

## REAR COMPARTMENT LID LOCK

Apply a thin coat of Lubriplate to lock bolt (Fig. 2-10).

## REAR COMPARTMENT HINGES AND TORQUE RODS

Apply Lubriplate and or driplless oil to frictional points as required. Wipe off excess lubricant.

## TAIL GATE WINDOW REGULATOR AND CAMS (station wagon)

Apply Lubriplate to areas indicated (Fig. 2-11).

## TAIL GATE LOCK STRIKER (station wagon)

Apply a thin coat of stick-type lubricant to surface of striker teeth. After lubrication, close tailgate

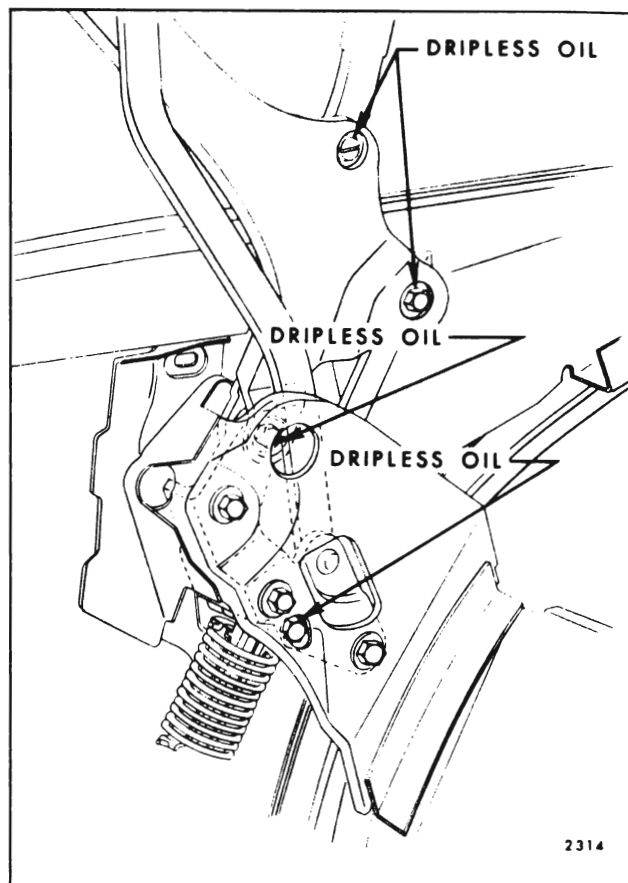

Fig. 2-14 — Convertible Top Linkage - "A" Styles (Manual Type Shown)

several times and remove excess lubricant (Fig. 2-12).

## TAIL GATE HINGES (station wagon)

Apply a sparing amount of driplless oil to frictional parts, work tail gate several times and remove excess lubricant.

## GAS TANK FILLER DOOR HINGE

Apply a few drops of driplless oil to frictional points of door hinge, work door several times and remove excess lubricant.

## FOLDING SEAT LINKAGE

Wipe off dirt and apply a sparing amount of driplless oil to all frictional areas. Work linkage several times and wipe off excess lubricant.

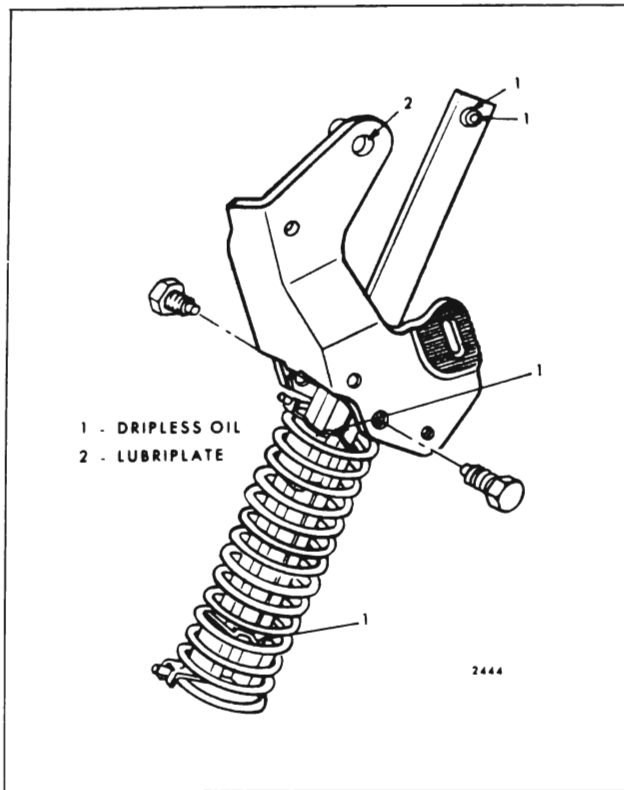

Fig. 2-15—Convertible Top Linkage - "F" Styles

### FRONT SEAT ADJUSTER MECHANISM (Manually and Electrically Operated)

Thoroughly wipe off old lubricant. Apply a thin coat of lubriplate to jack screws and tracks. Operate seat to limits of all positions. Apply a small amount of dripless oil to linkage and wipe off excess lubricant.

### CONVERTIBLE TOP LINKAGE

Apply Lubriplate or dripless oil to points indicated (Fig. 2-13, 2-14 and 2-15). Wipe off excess lubricant to prevent soiling trim.