

SECTION A

SHIFT LINKAGE ADJUSTMENTS ALL SERIES

CONTENTS

Division	Paragraph	Subject	Page
I		SPECIFICATIONS AND ADJUSTMENTS:	
	73-1	Super Turbine 300 Transmission Shift Linkage Adjustment (43-4400 Series)	73-3
	73-2	Super Turbine 300 Transmission Shift Linkage Adjustment (Console Shift)	73-6
	73-3	Super Turbine 300 Transmission Shift Linkage Adjustment (45000 Series)	73-8
	73-4	Super Turbine 400 Transmission Shift Linkage Adjustment (45-46-48000 Series)	73-11
	73-5	Super Turbine 400 Transmission Shift Linkage Adjustment (46000 Console Shift)	73-14
	73-6	Super Turbine 400 Transmission Shift Linkage Adjustment (49000 Column Shift)	73-17
	73-7	Super Turbine 400 Transmission Shift Linkage Adjustment (49000 Console Shift)	73-20
	73-8	3-Speed Manual Transmission Shift Linkage Adjustment (43-4400 Series)	73-23
	73-9	3-Speed Manual Transmission Shift Linkage Adjustment (Skylark Gran Sport)m.	73-28
	73-10	3-Speed Manual Transmission Shift Linkage Adjustment (45000 Series)	73-31
	73-11	3-Speed Manual Transmission Shift Linkage Adjustment (46000 Series)	73-35
	73-12	4-Speed Manual Transmission Shift Linkage Adjustment (Skylark Gran Sport)	73-39
II		DESCRIPTION AND OPERATION: Not Applicable	
III		SERVICE PROCEDURES: Not Applicable	
IV		TROUBLE DIAGNOSIS: Not Applicable	

DIVISION I

SPECIFICATIONS AND ADJUSTMENTS

73-1 SUPER TURBINE 300 TRANSMISSION SHIFT LINKAGE ADJUSTMENT



Figure 73-1

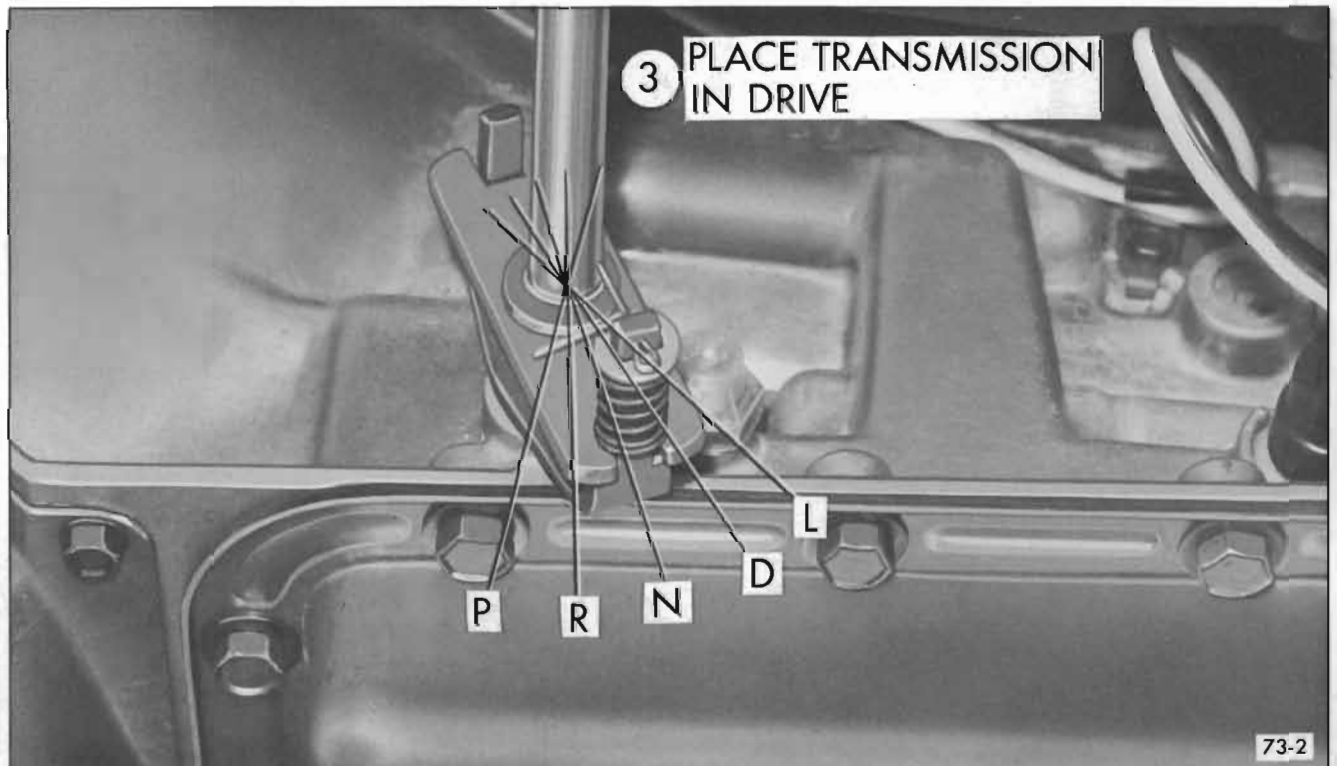
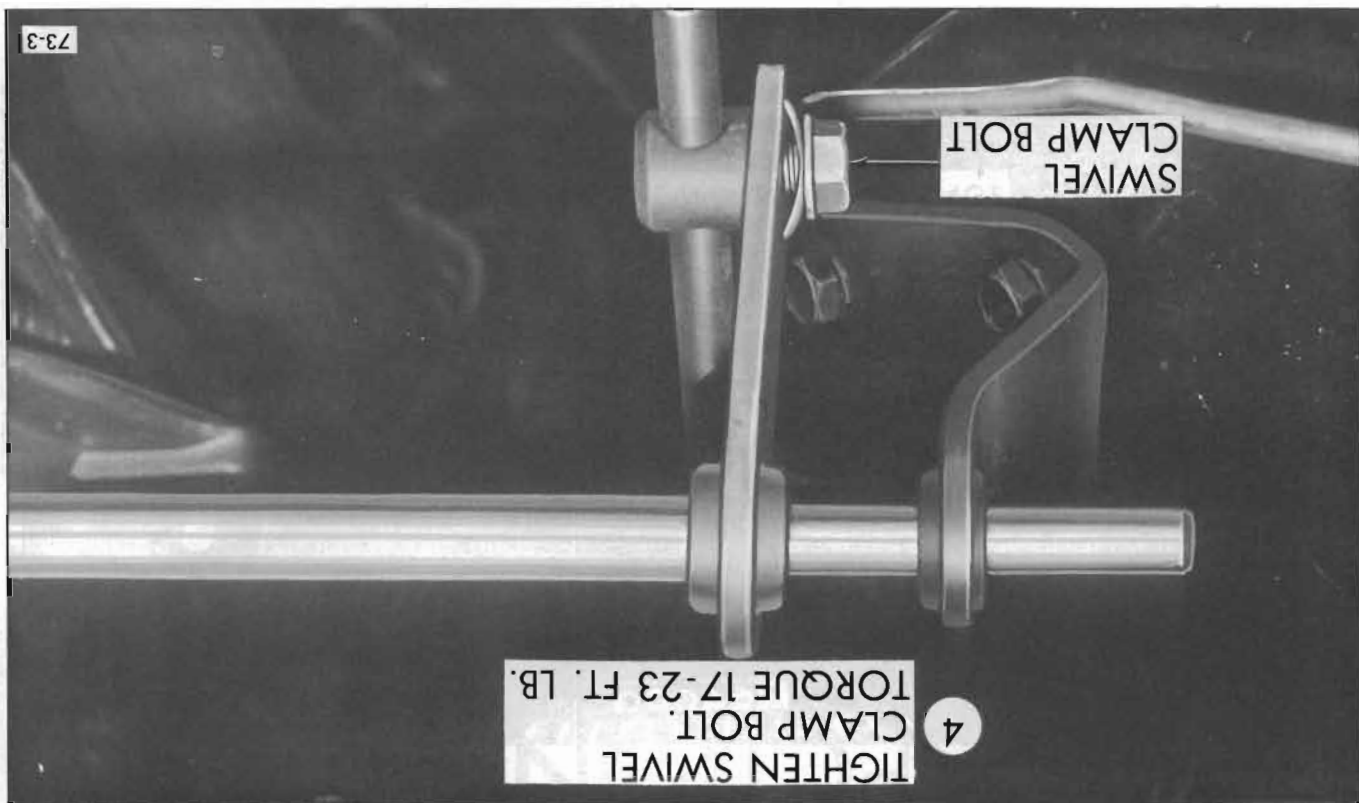
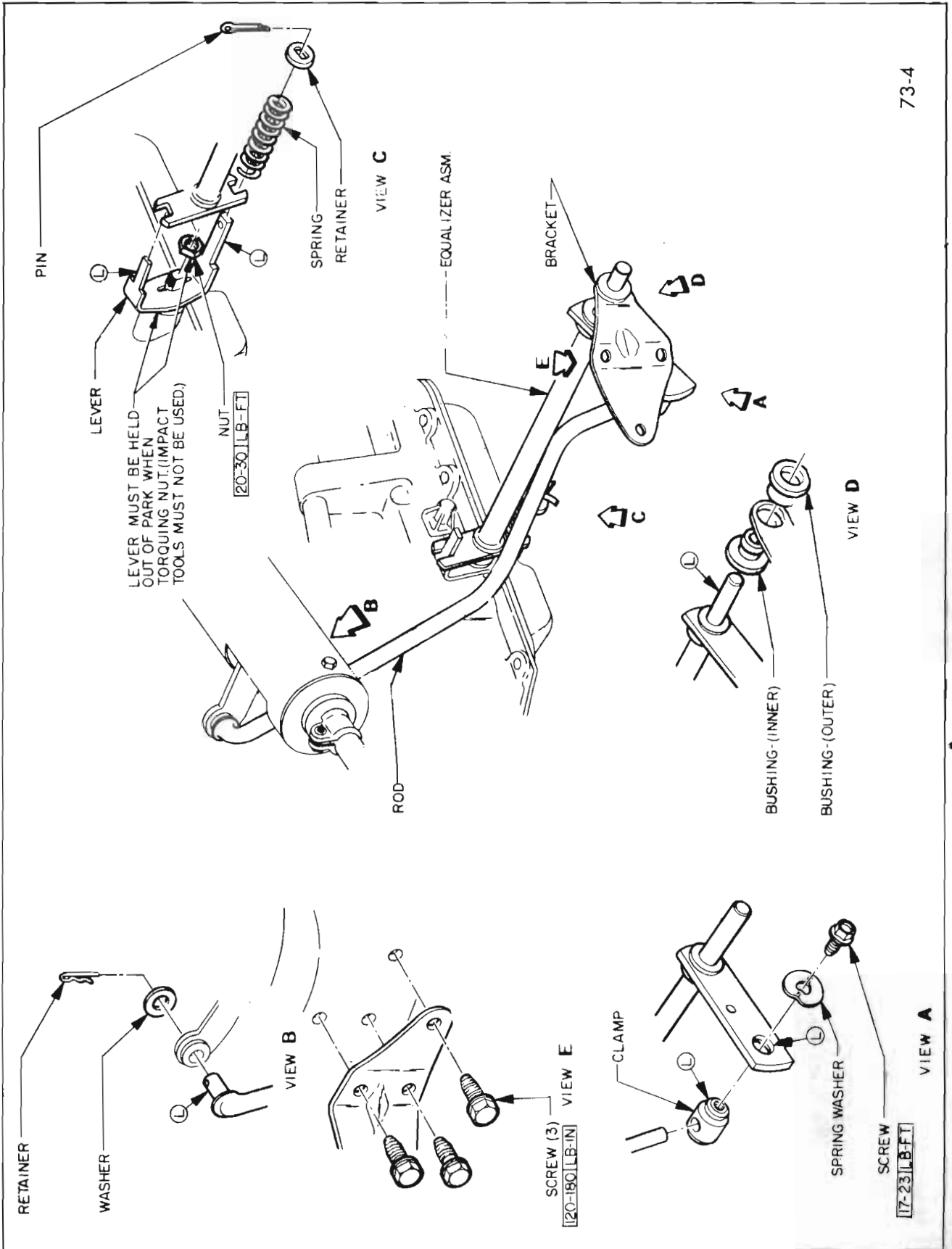

Figure 73-2



Figure 73-3





73-4

Fig. 73-4-43-44000

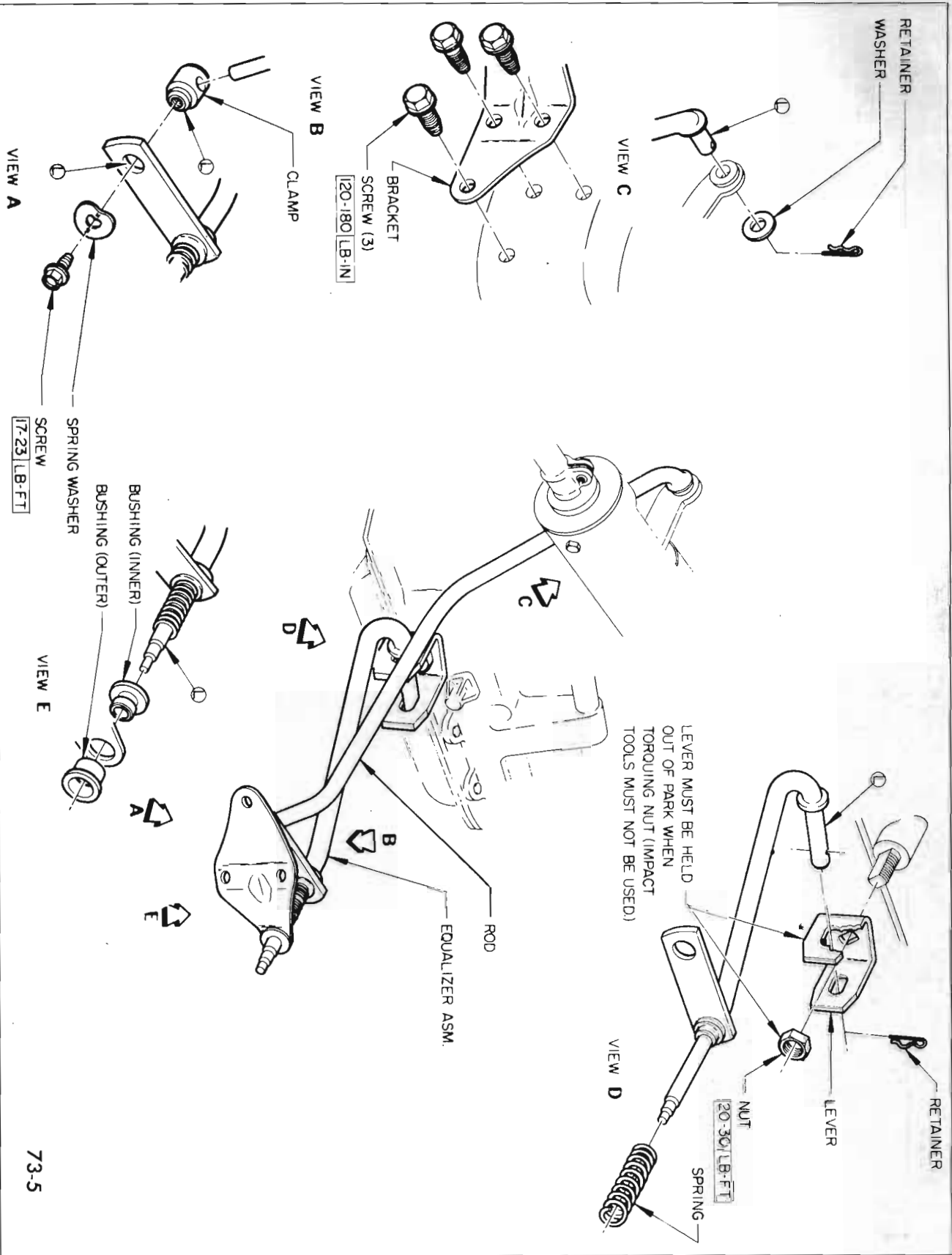

Figure 73-5—Skylark Gran Sport Column Shift

73-2 SUPER TURBINE 300 TRANSMISSION SHIFT LINKAGE ADJUSTMENT (CONSOLE SHIFT)



Figure 73-6

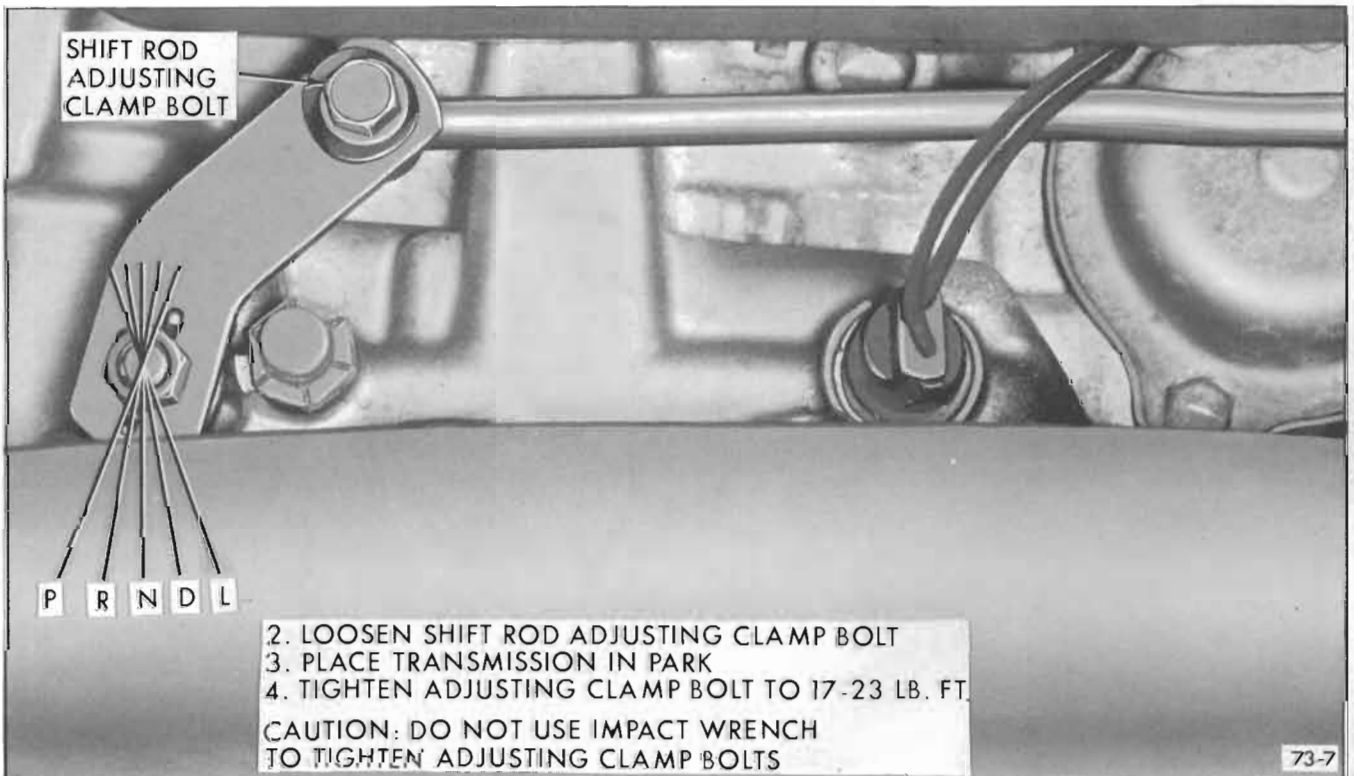

Figure 73-7

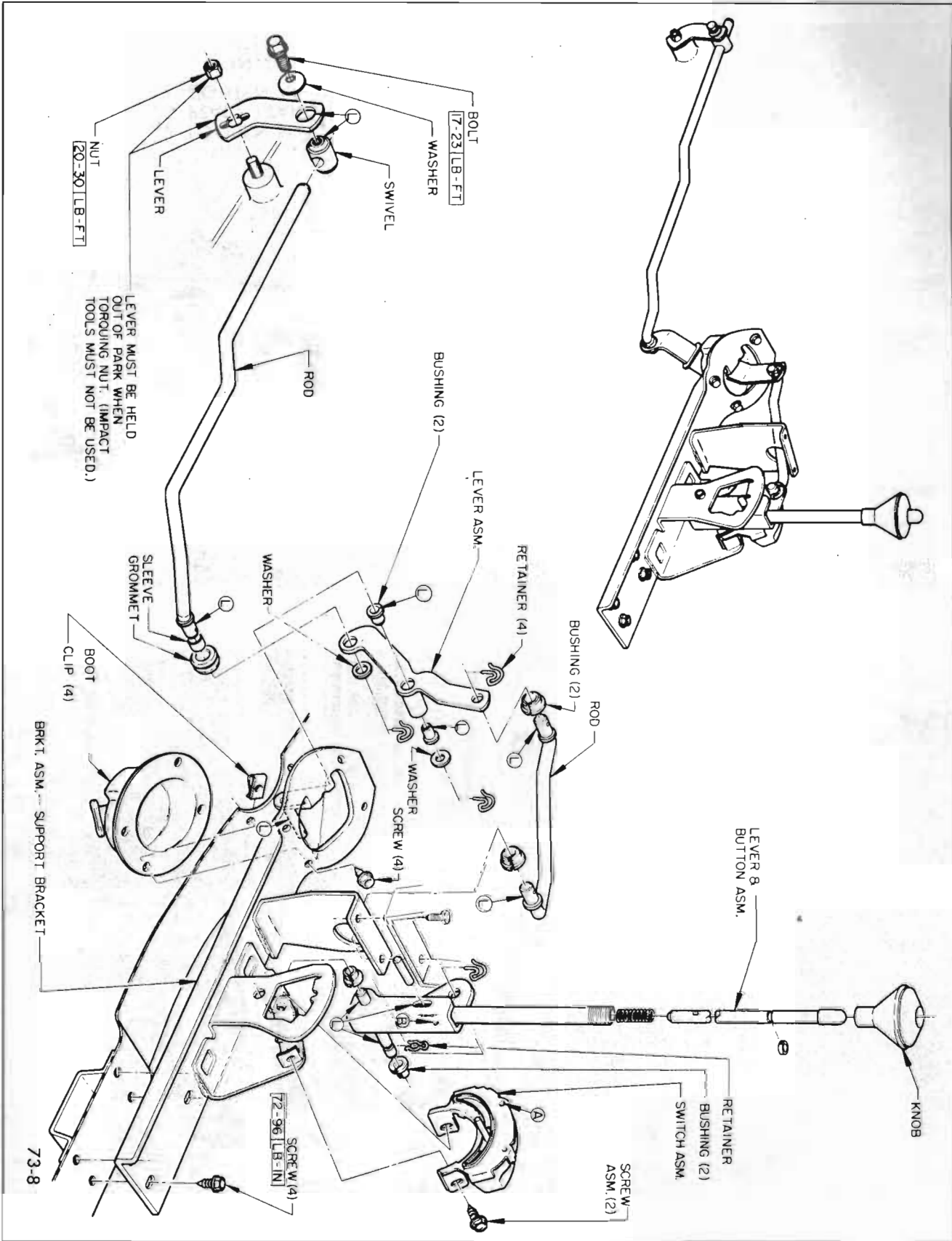

Figure 73-8

73-3 SUPER TURBINE 300 TRANSMISSION SHIFT LINKAGE ADJUSTMENT (45000 SERIES)



Figure 73-9

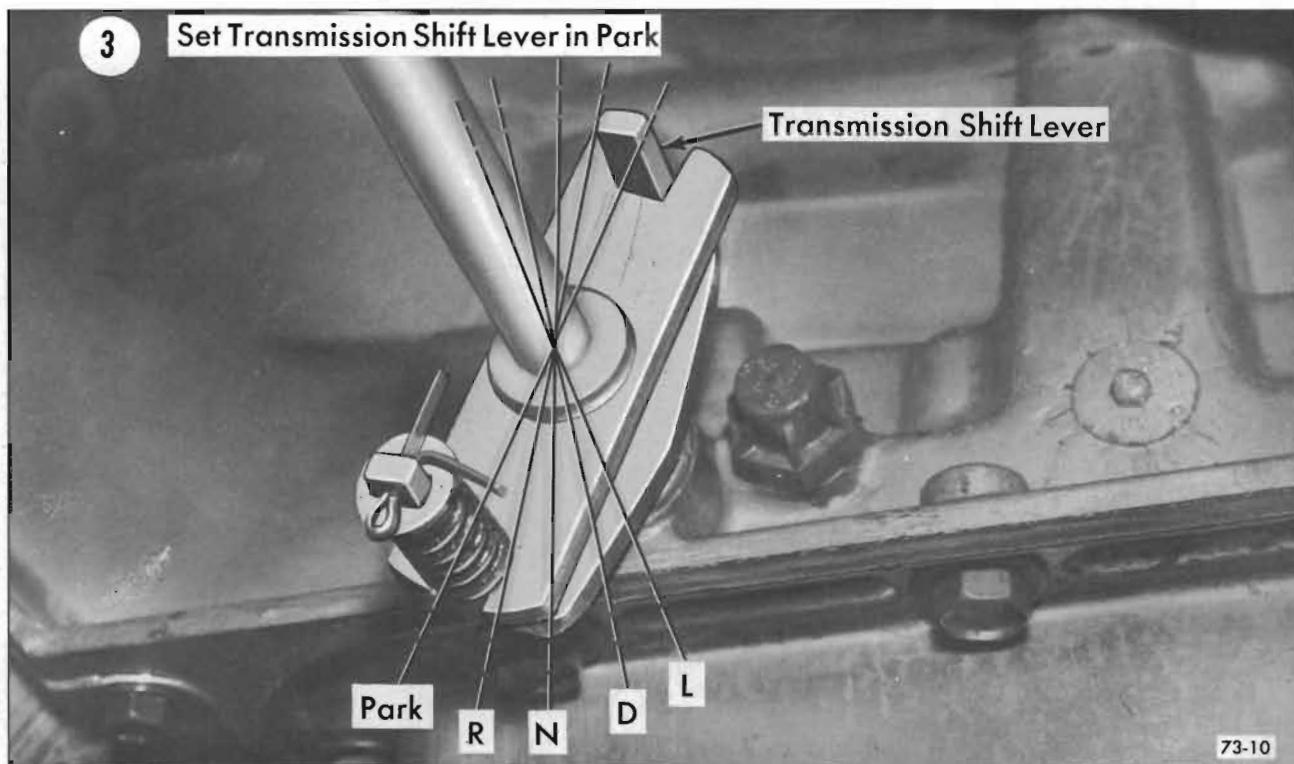
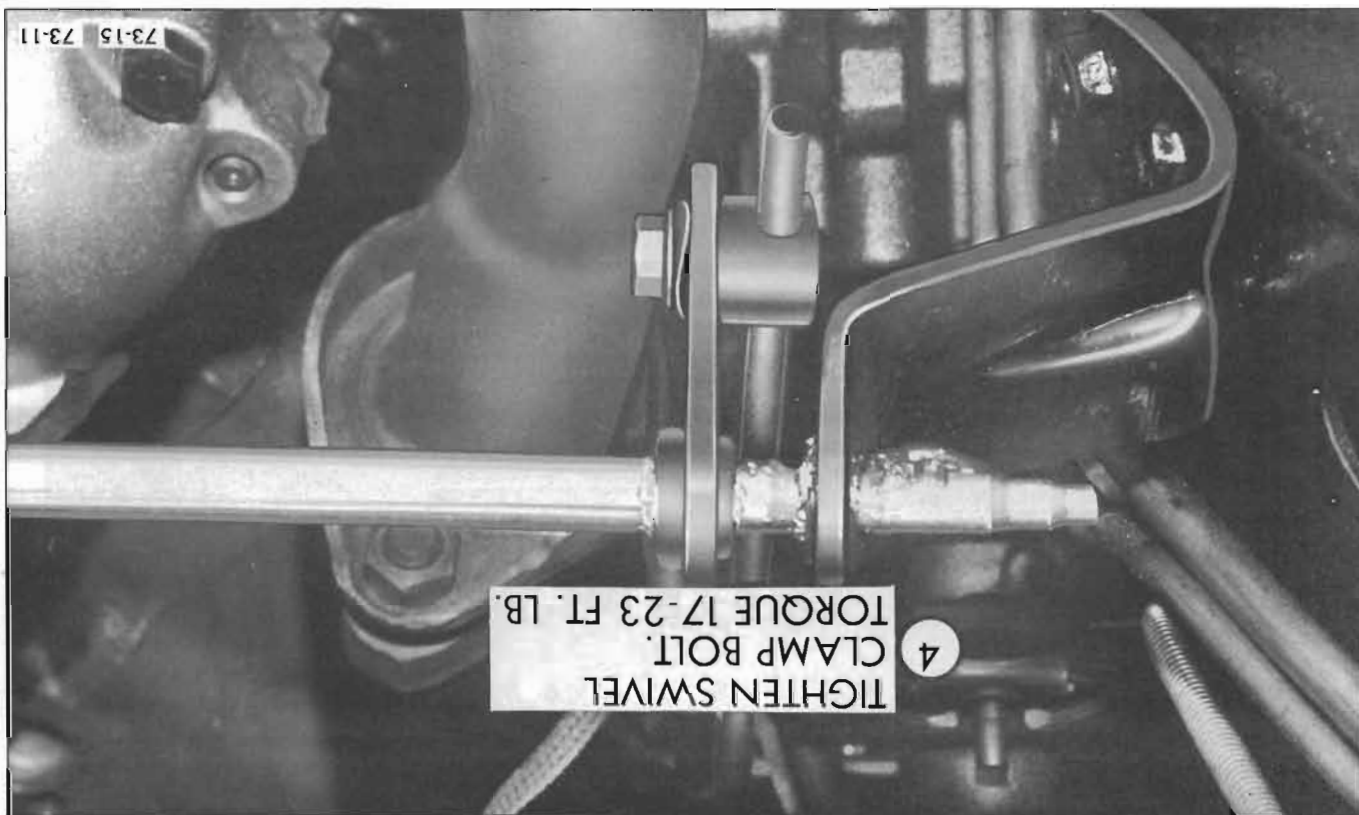

Figure 73-10

Figure 73-11



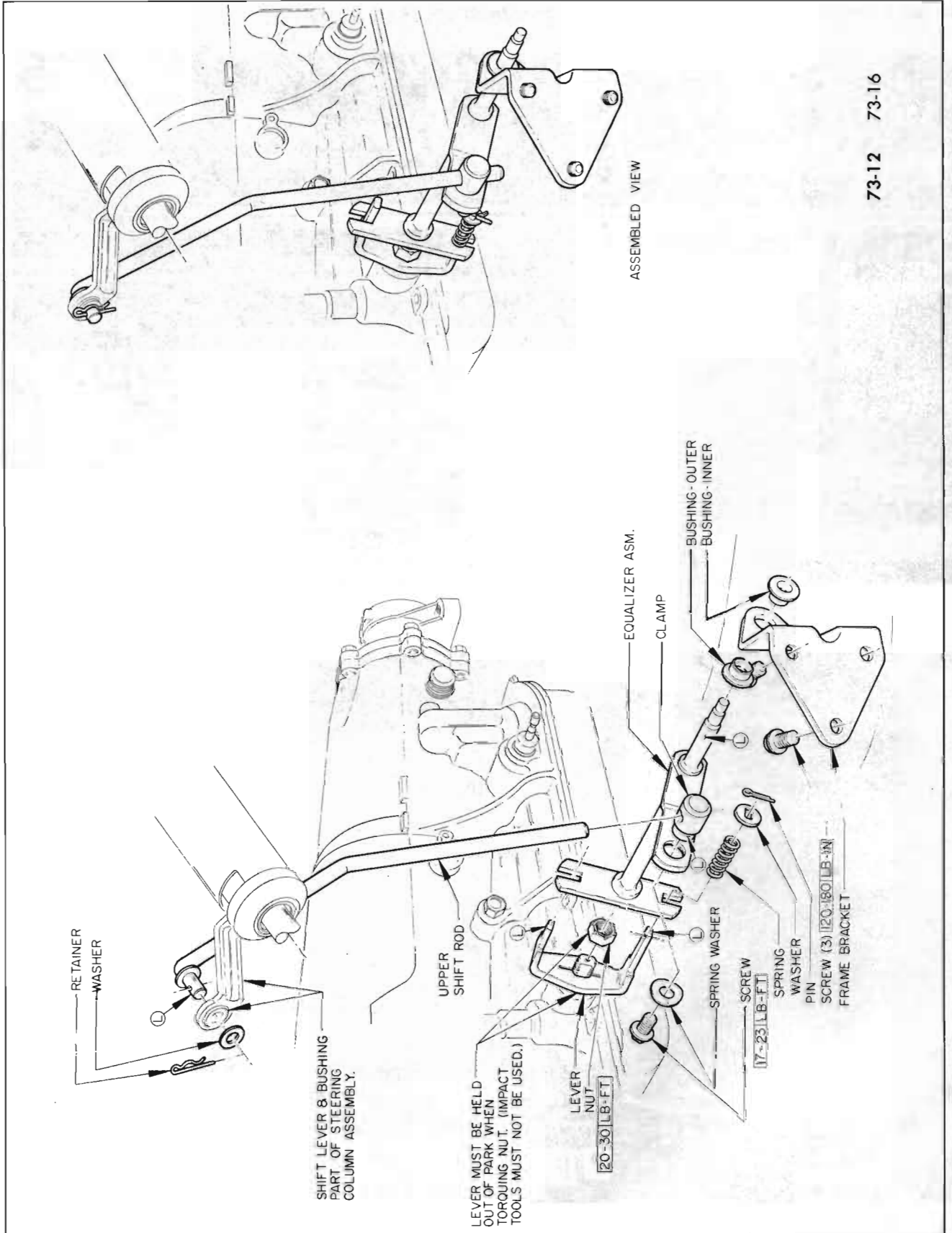

Figure 73-12

Figure 73-14

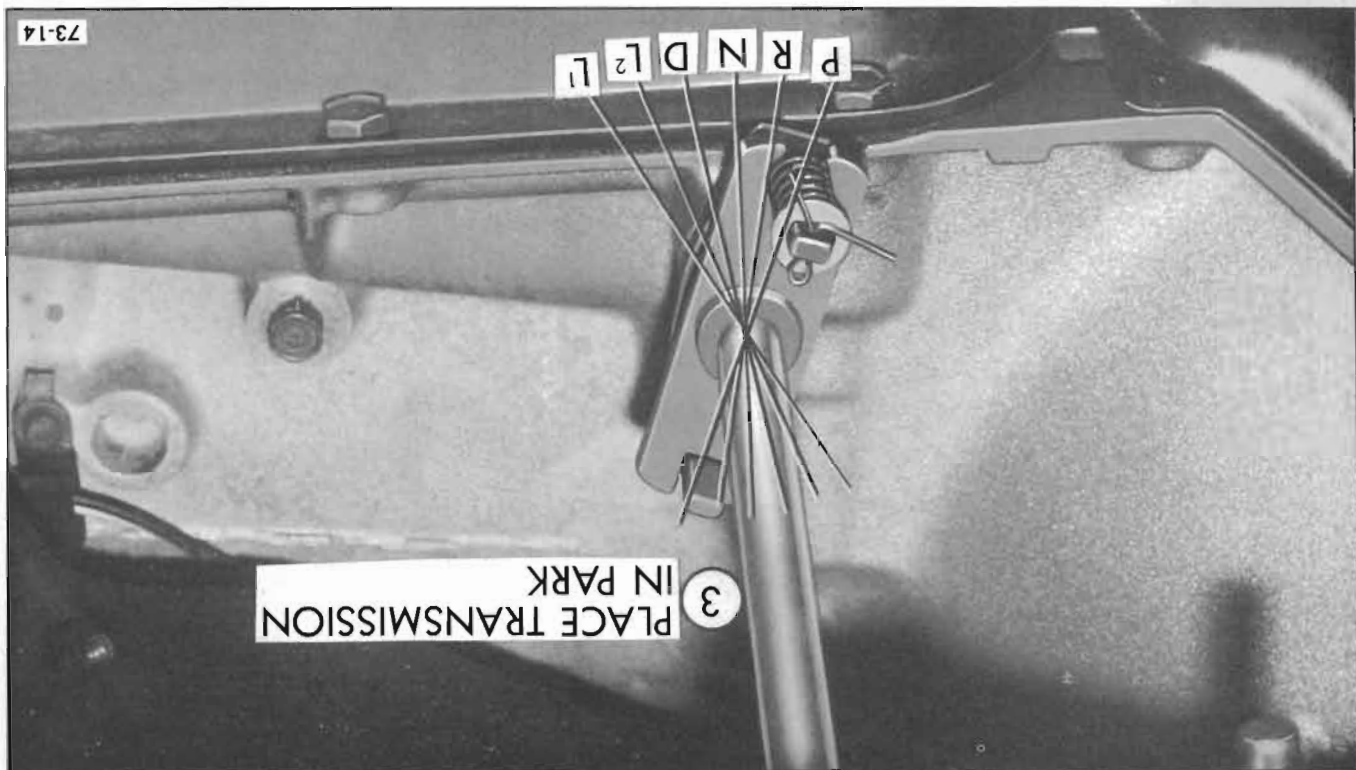

Figure 73-13



73-4 SUPER TURBINE 400 TRANSMISSION SHIFT LINKAGE ADJUSTMENT (45-46-48000 SERIES)

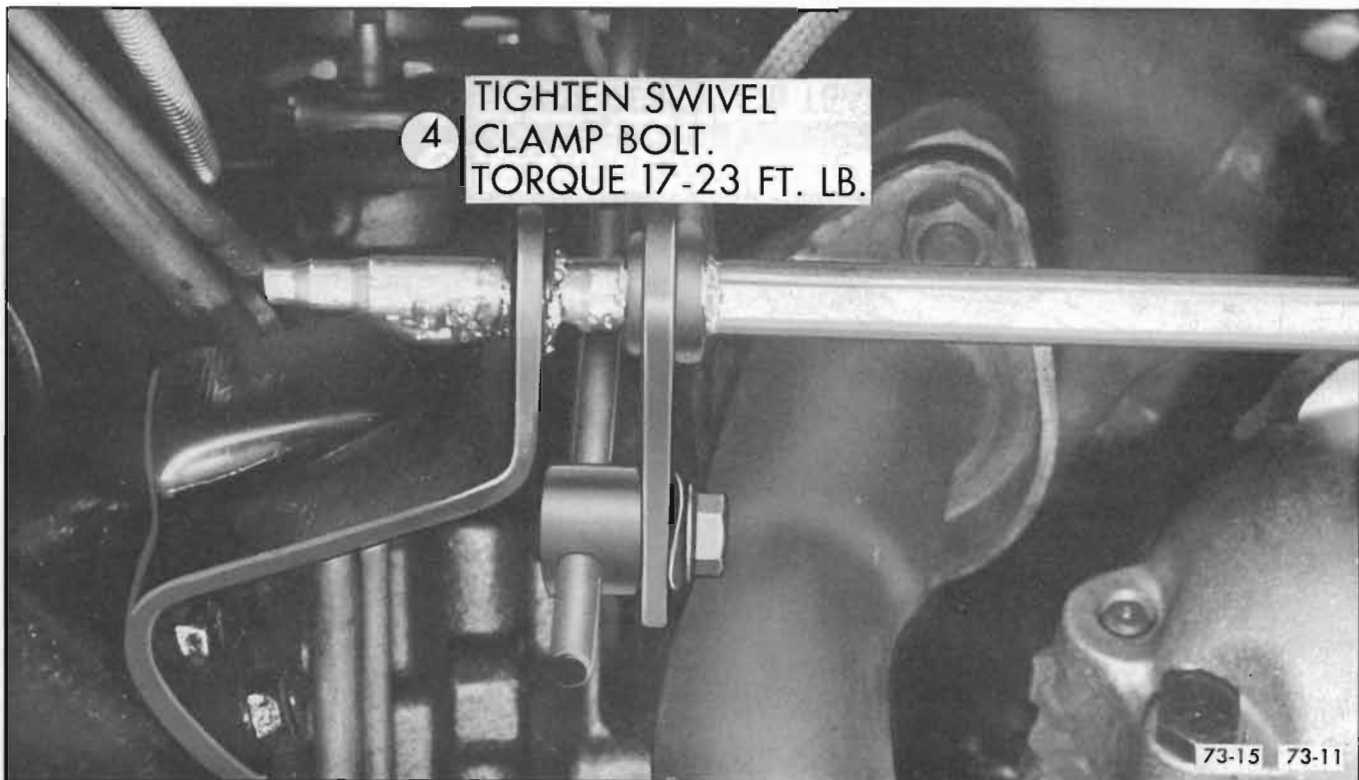

Figure 73-15

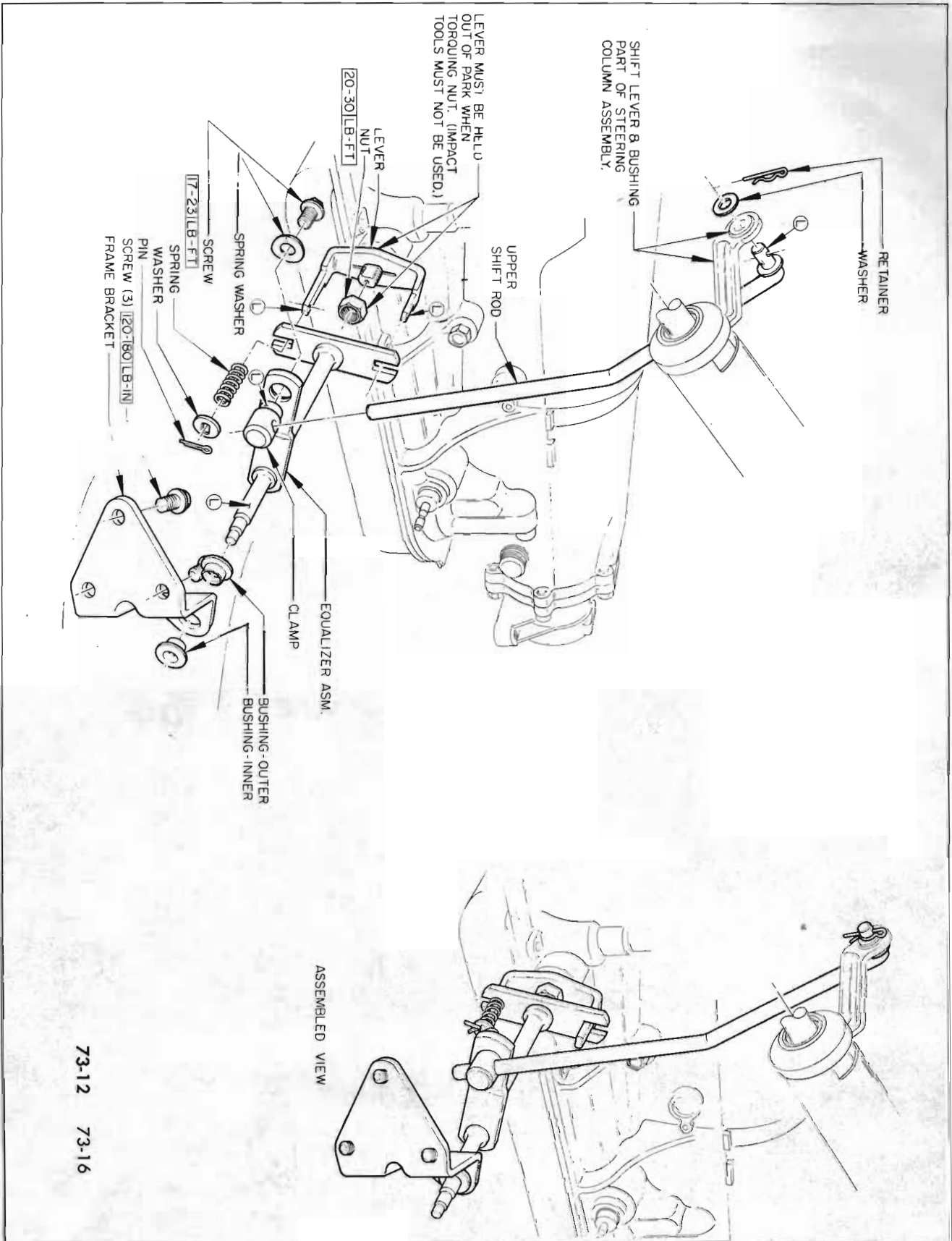

Figure 73-16

73-5 SUPER TURBINE 400 TRANSMISSION SHIFT LINKAGE ADJUSTMENT (46000 CONSOLE SHIFT)

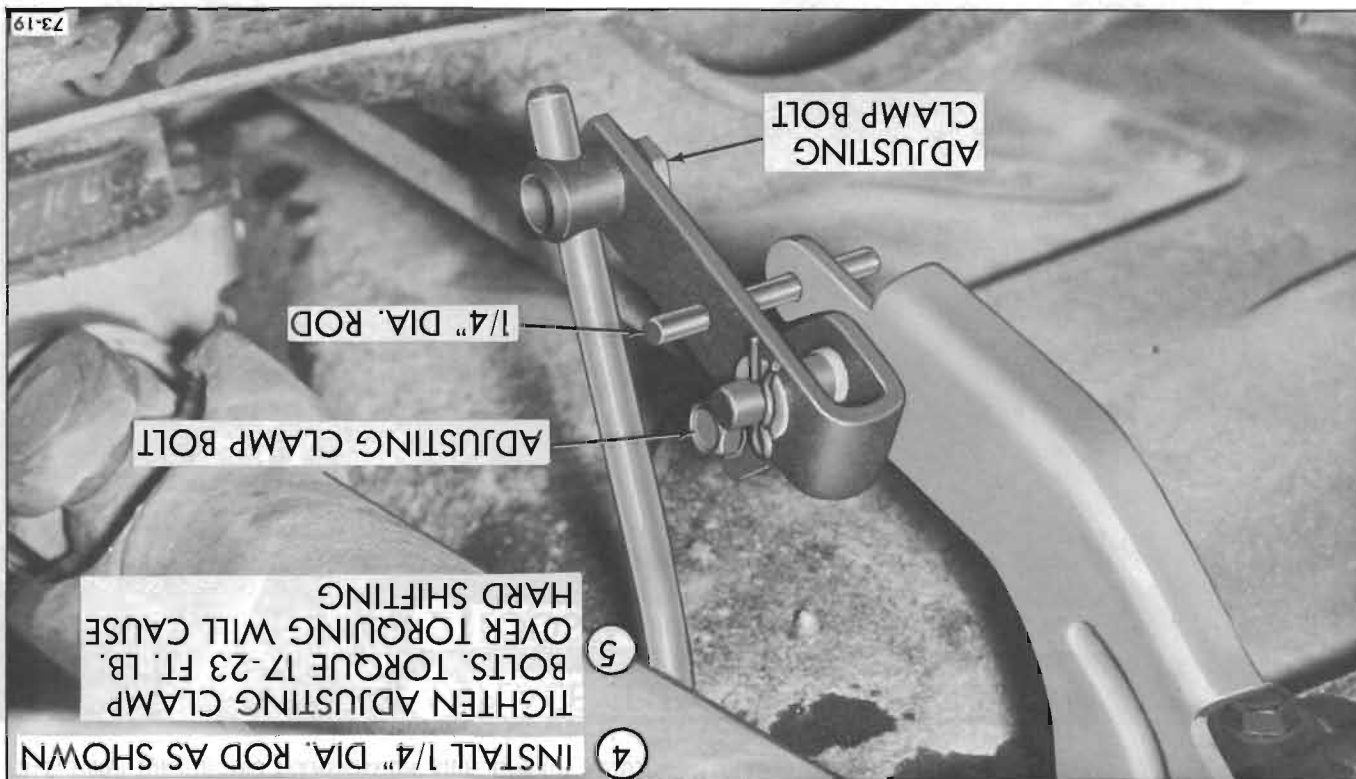

Figure 73-17



Figure 73-18

Figure 73-19



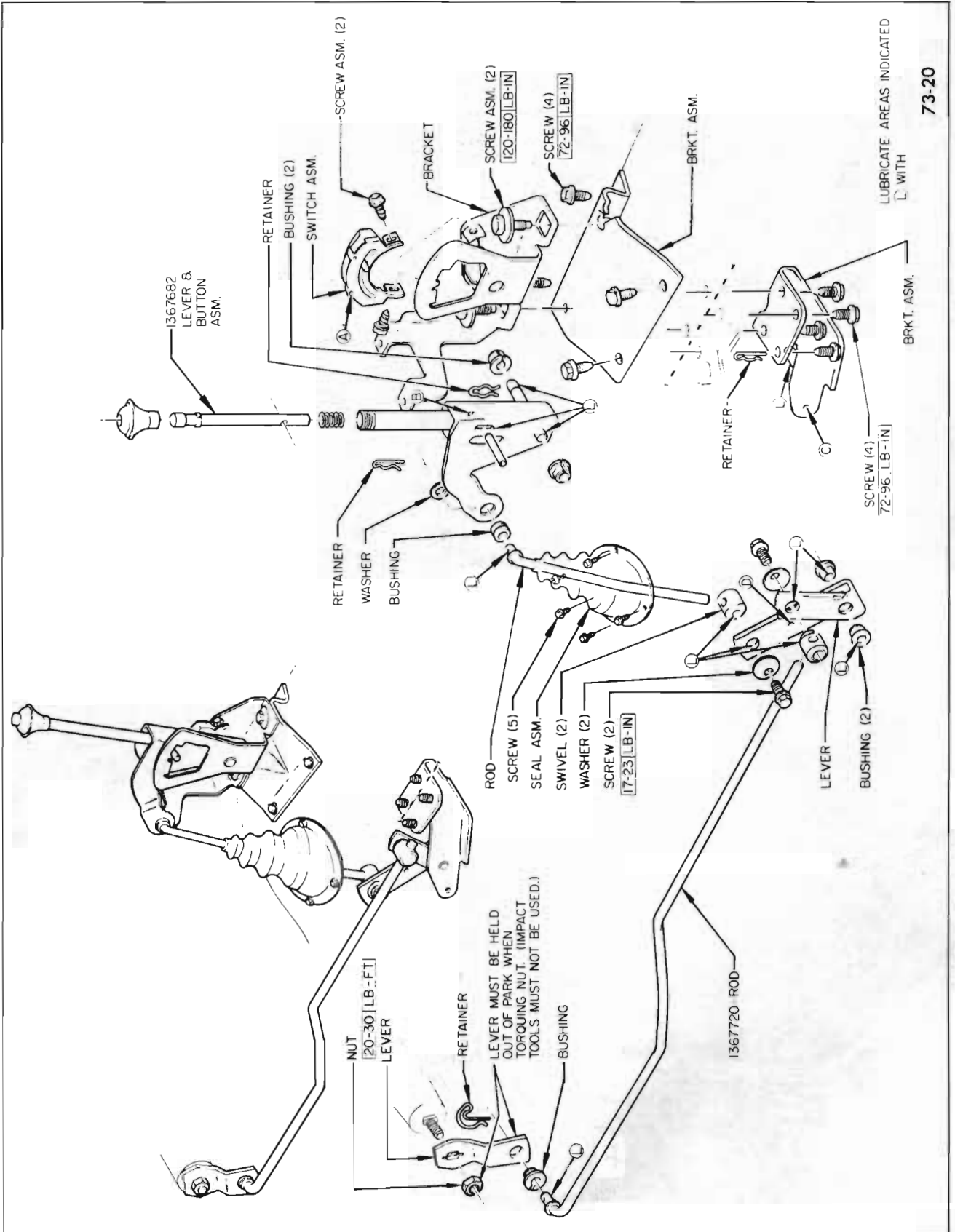

Figure 73-20

Figure 73-22

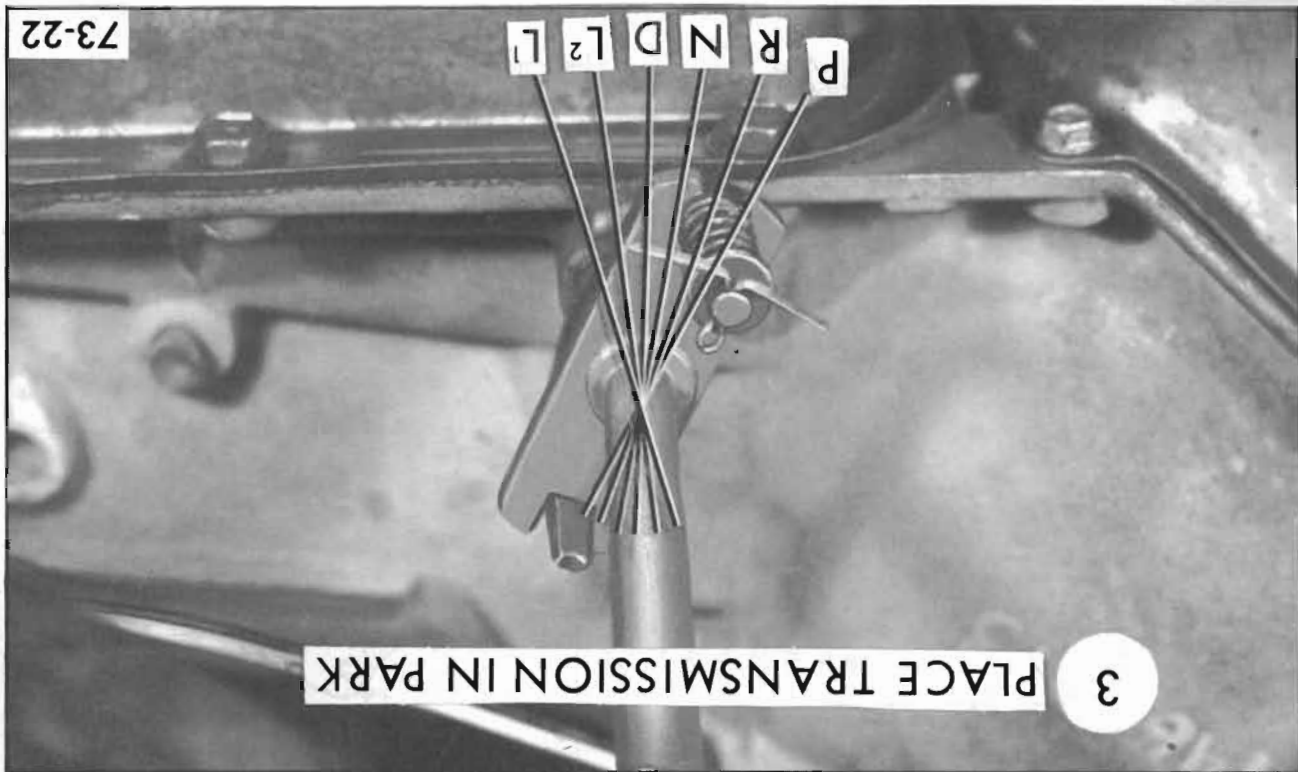
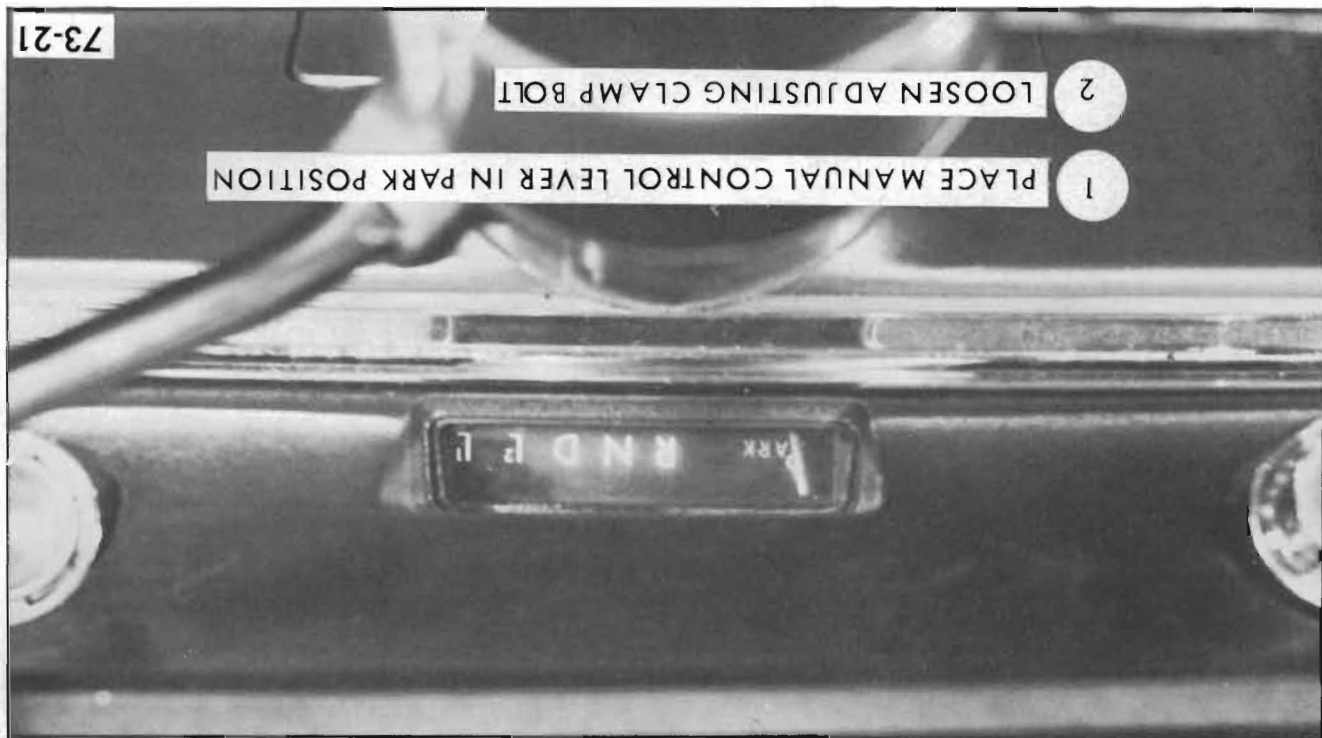

Figure 73-21



73-6 SUPER TURBINE 400 TRANSMISSION SHIFT LINKAGE ADJUSTMENT (49000 SERIES COLUMN SHIFT)



Figure 73-23

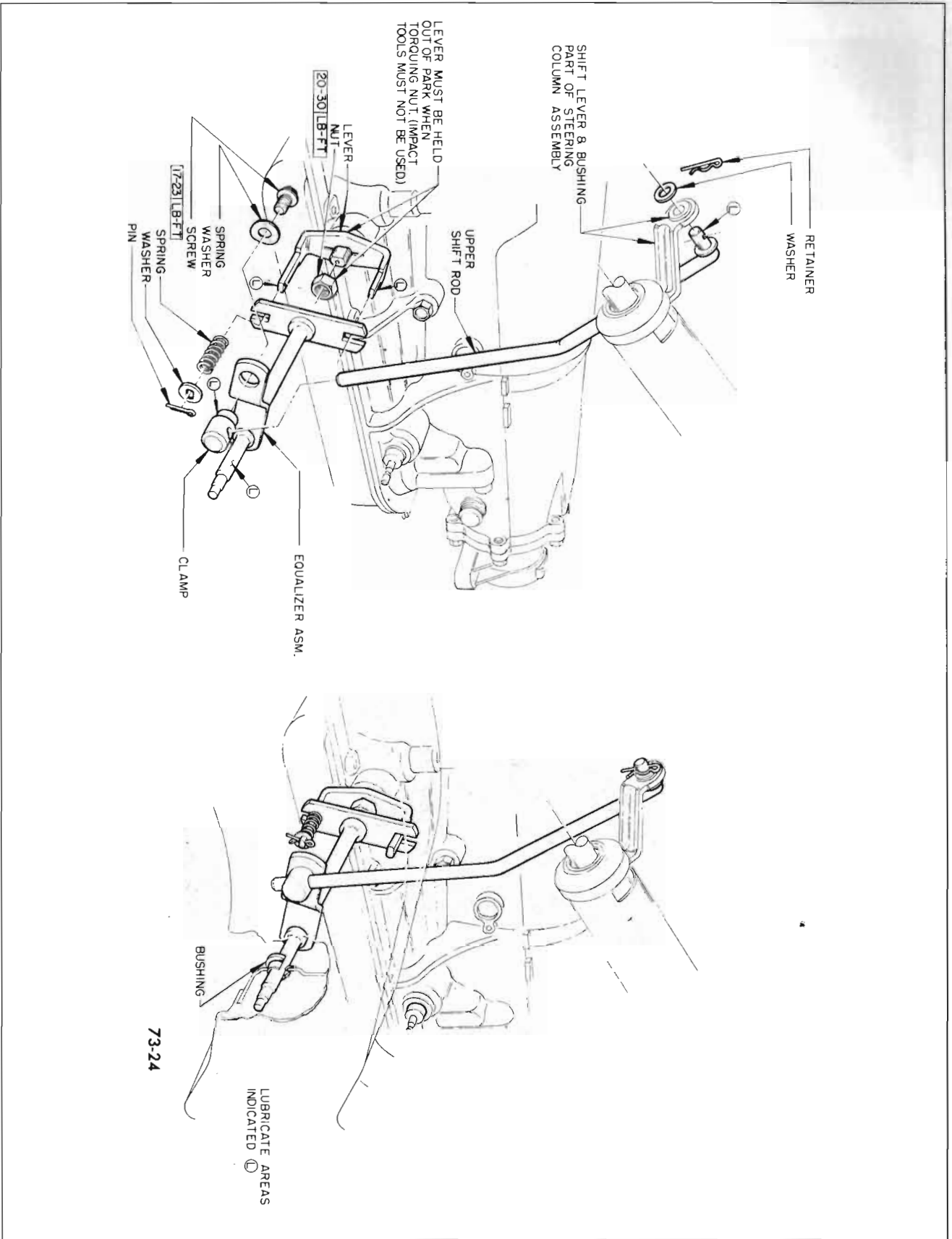
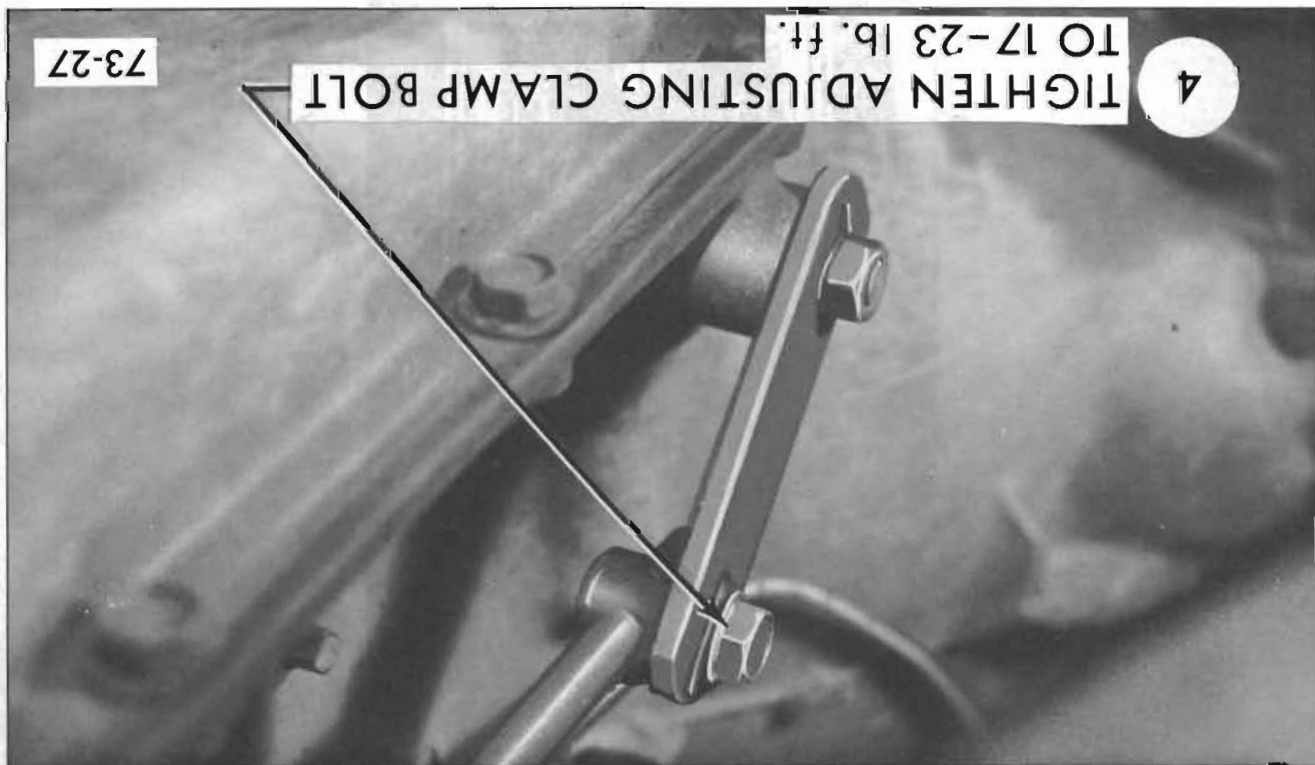
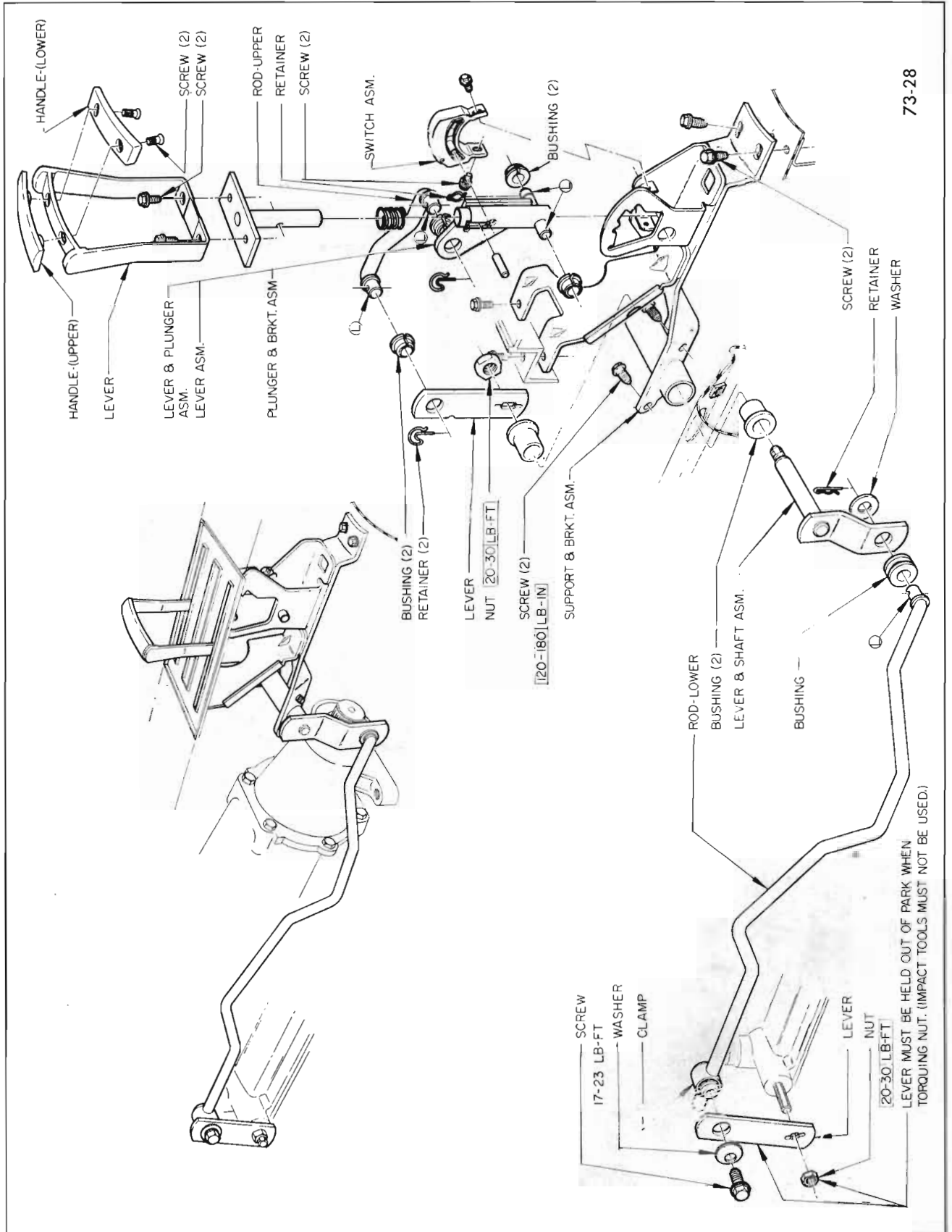

Figure 73-24



Figure 73-27





73-28

Figure 73-28

Figure 73-30

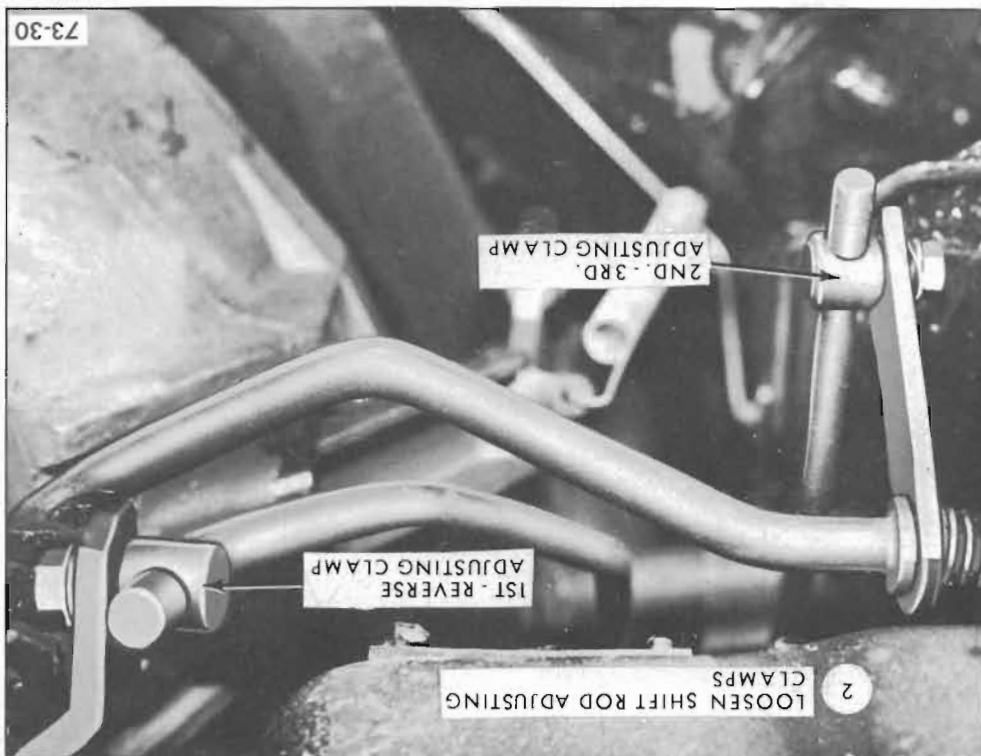
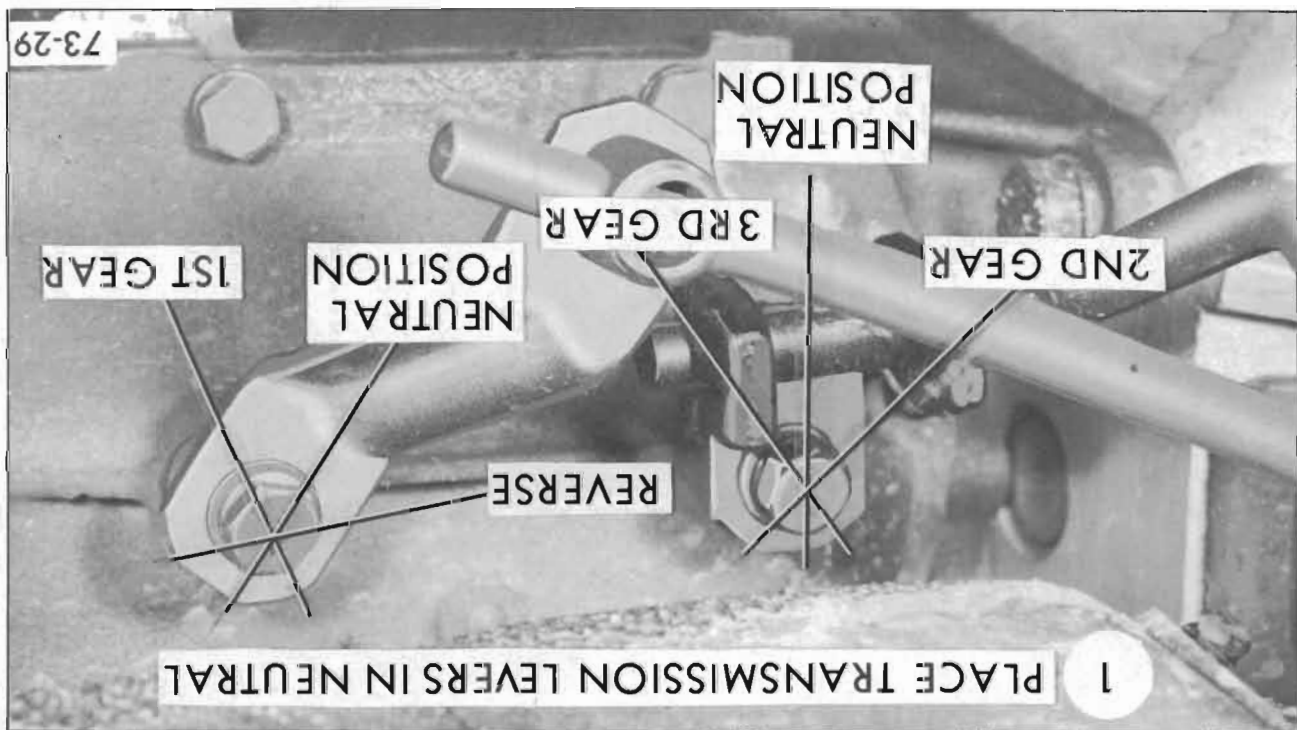

Figure 73-29



73-8 3-SPEED MANUAL TRANSMISSION SHIFT LINKAGE ADJUSTMENT (43-44000 SERIES)



Figure 73-31

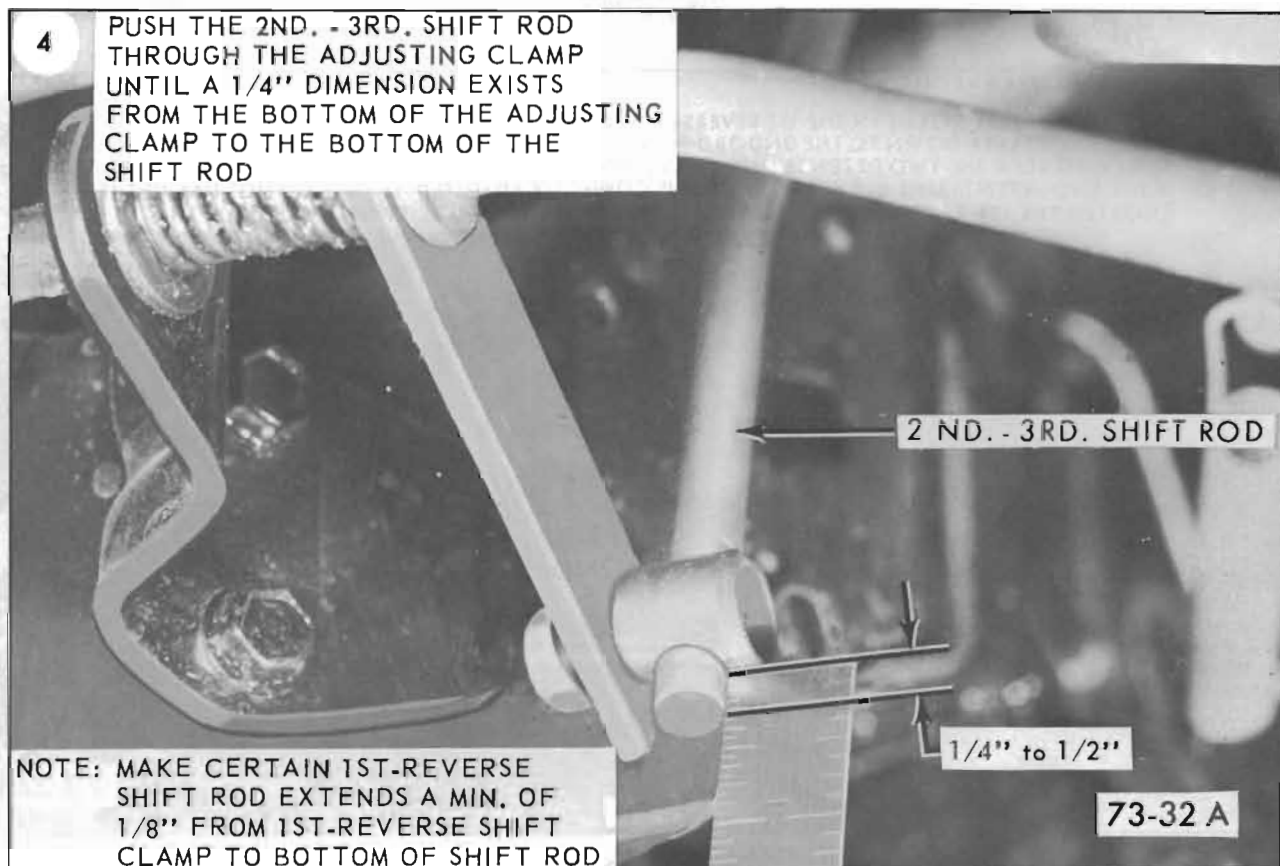

Figure 73-32

Figure 73-34

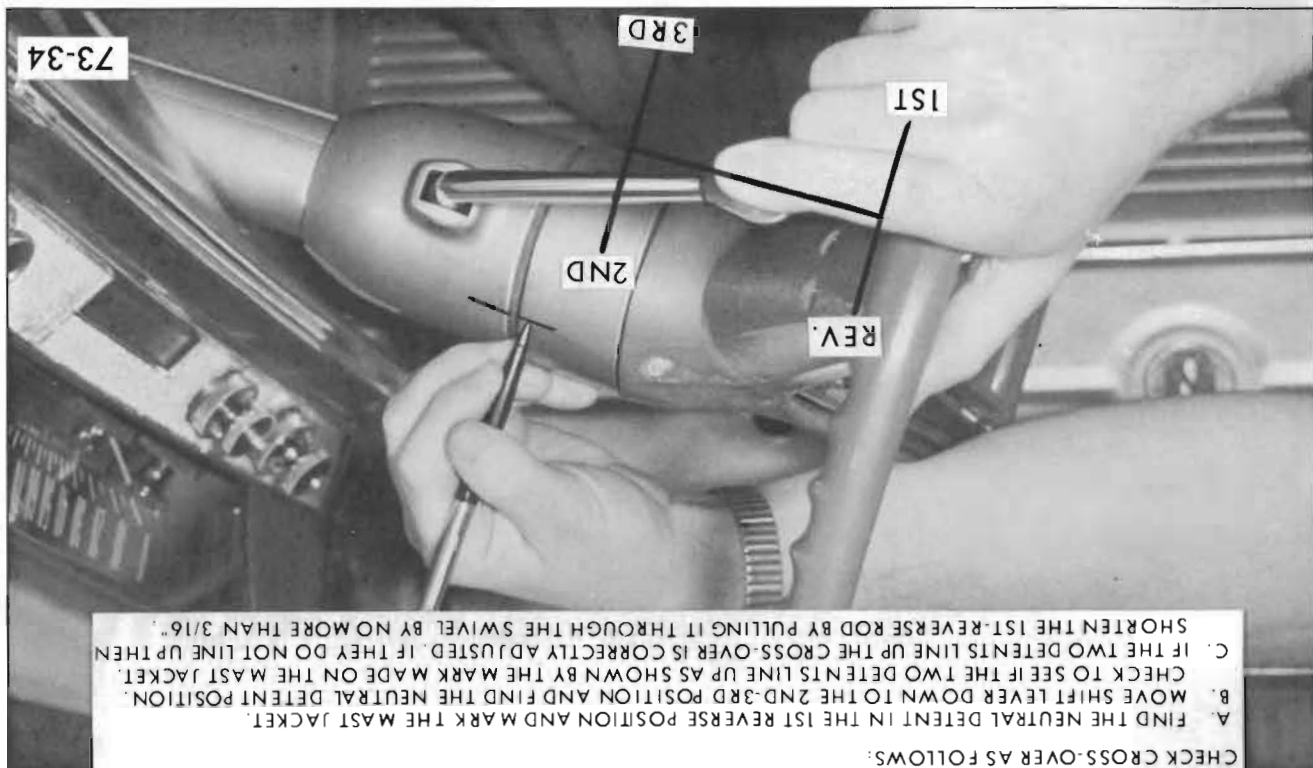

Figure 73-33

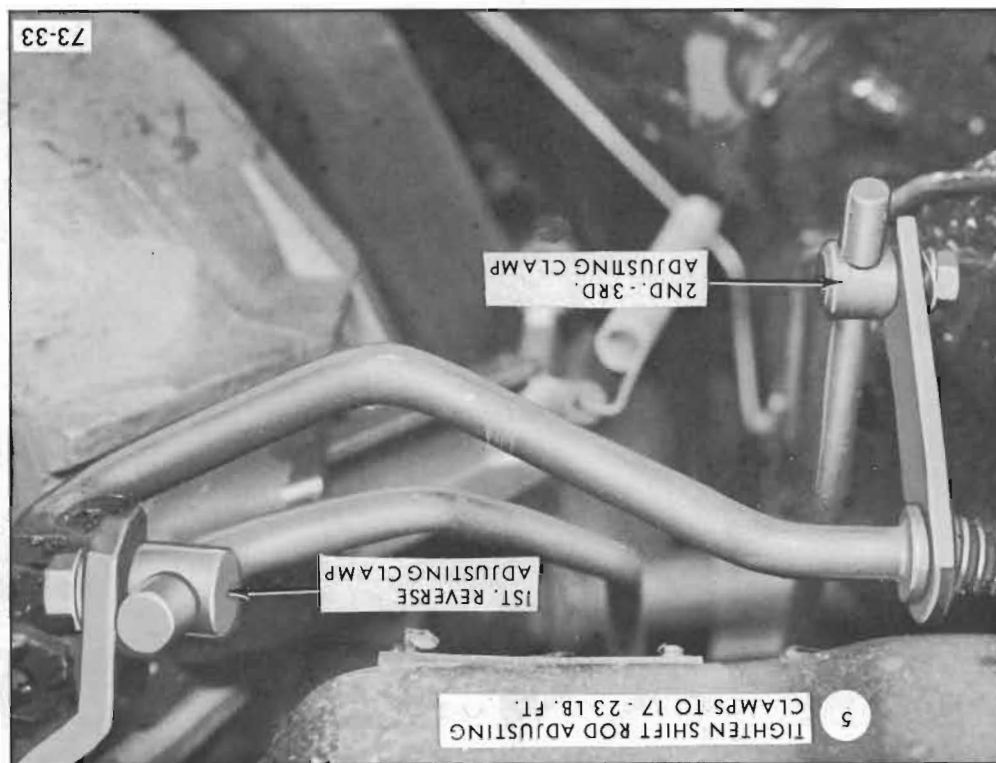



Figure 73-35

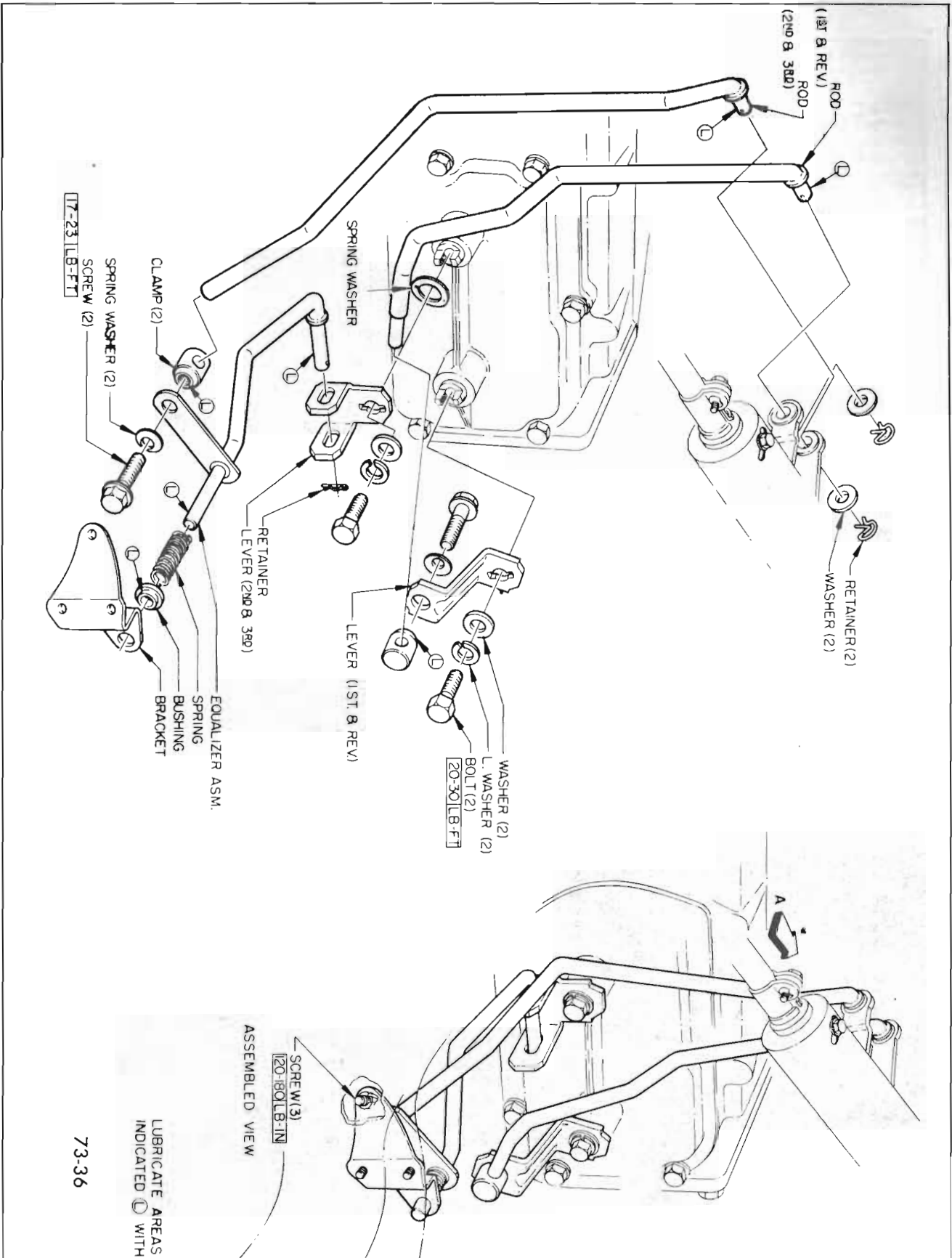

Figure 73-36

73-9 3-SPEED MANUAL TRANSMISSION SHIFT LINKAGE ADJUSTMENT (SKYLARK GRAN SPORT)

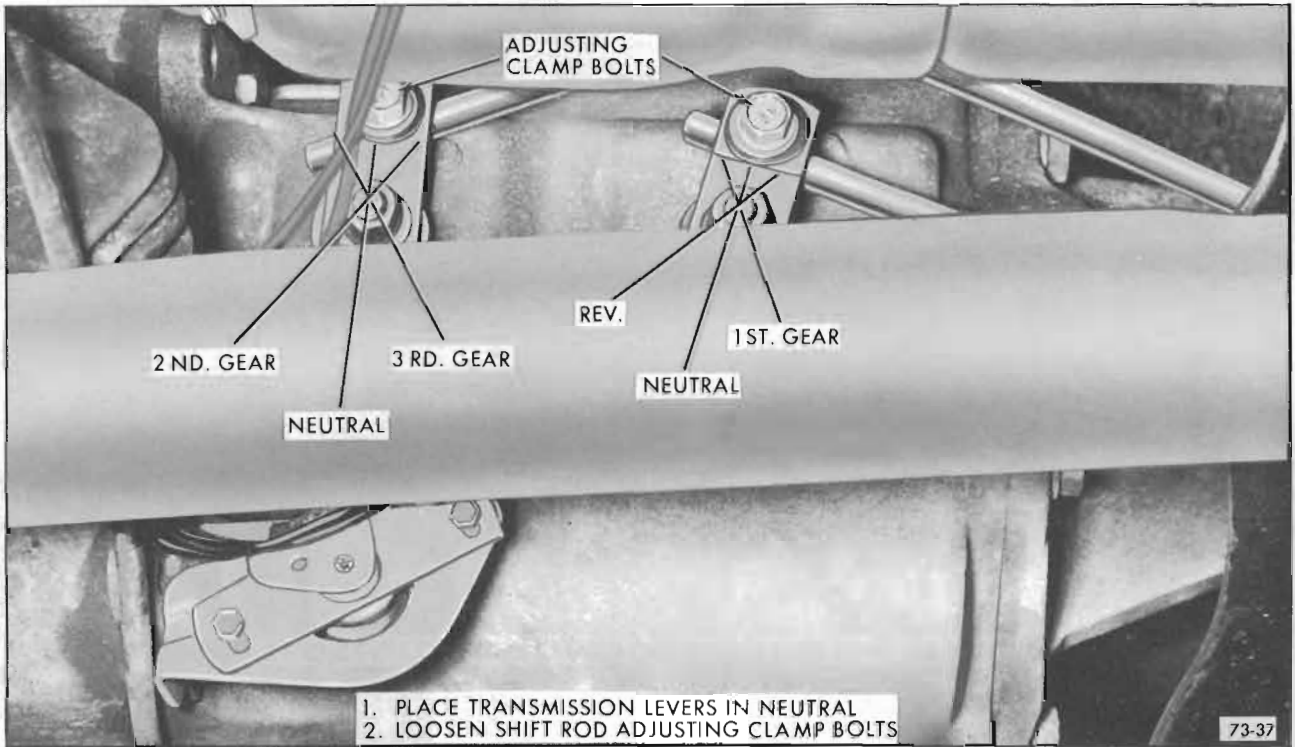

Figure 73-37

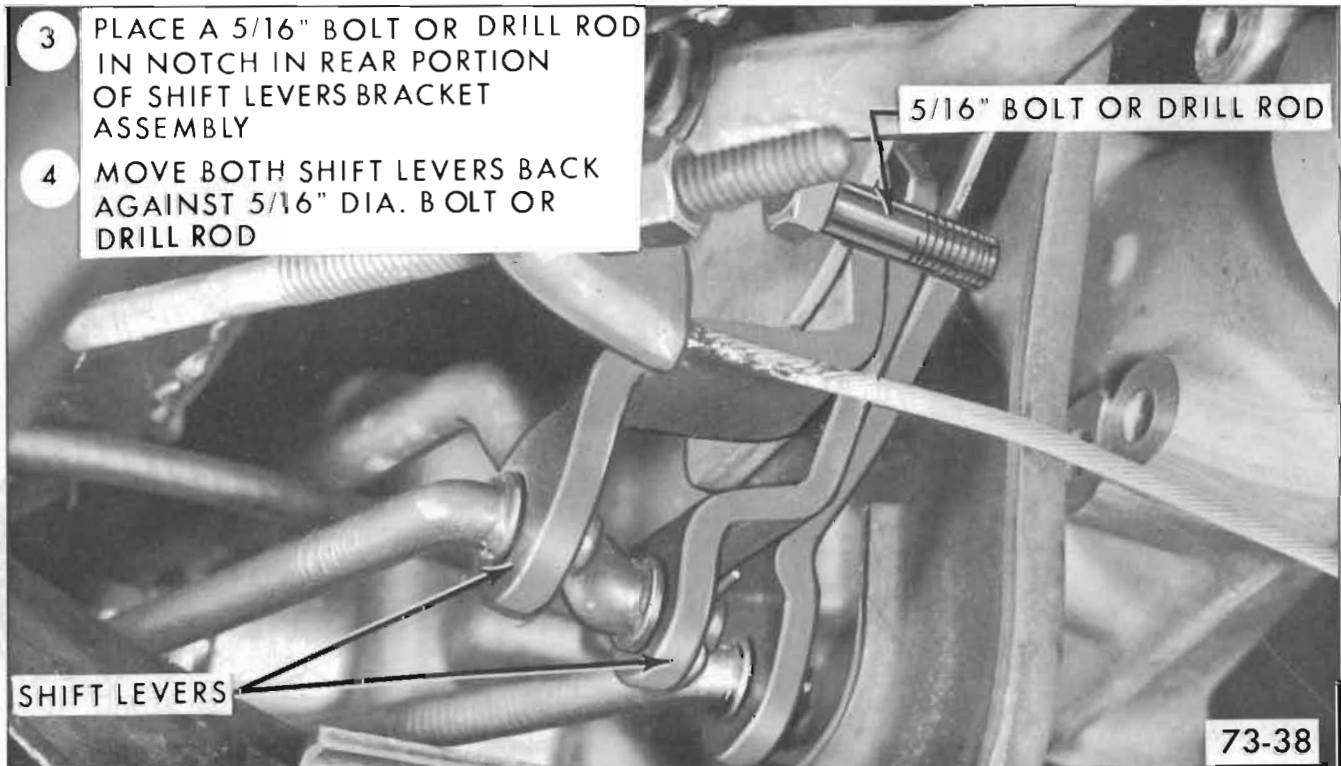
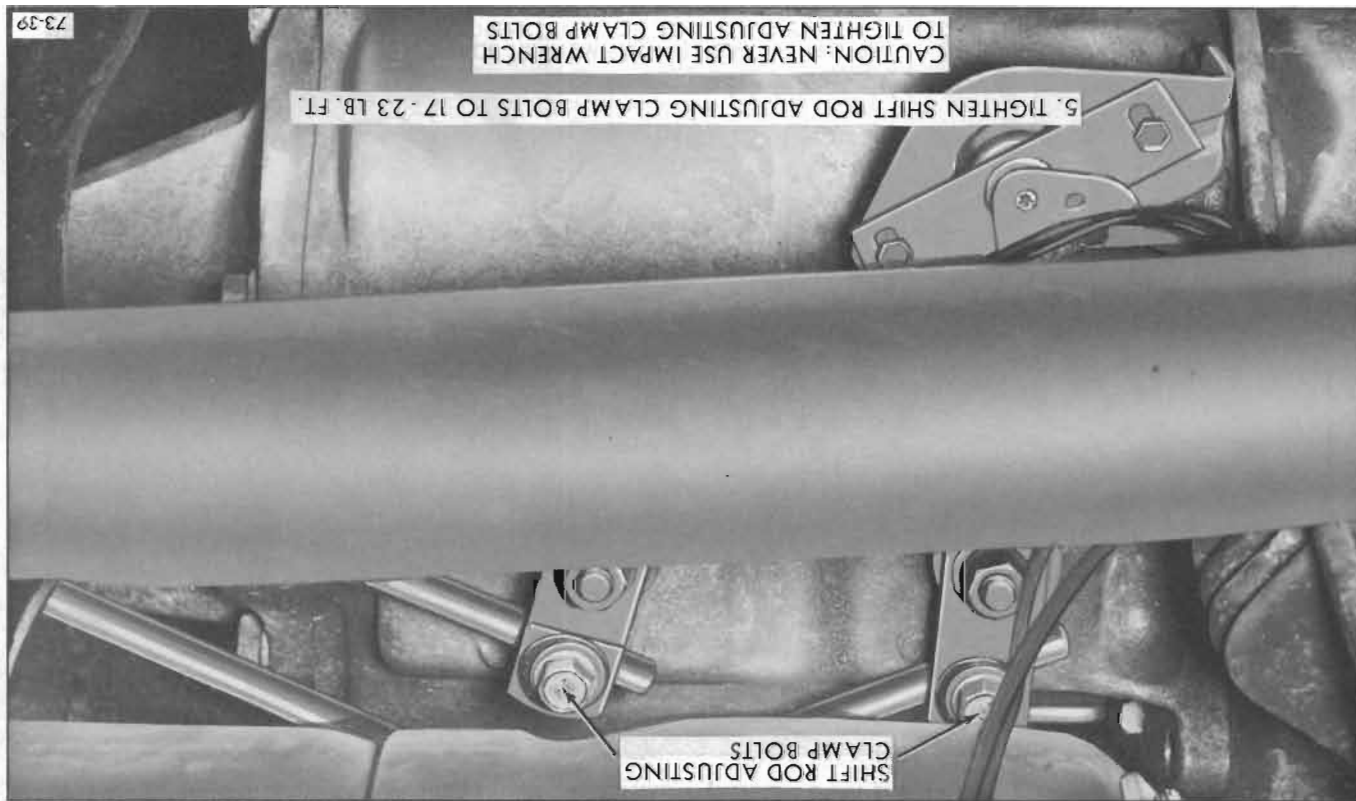
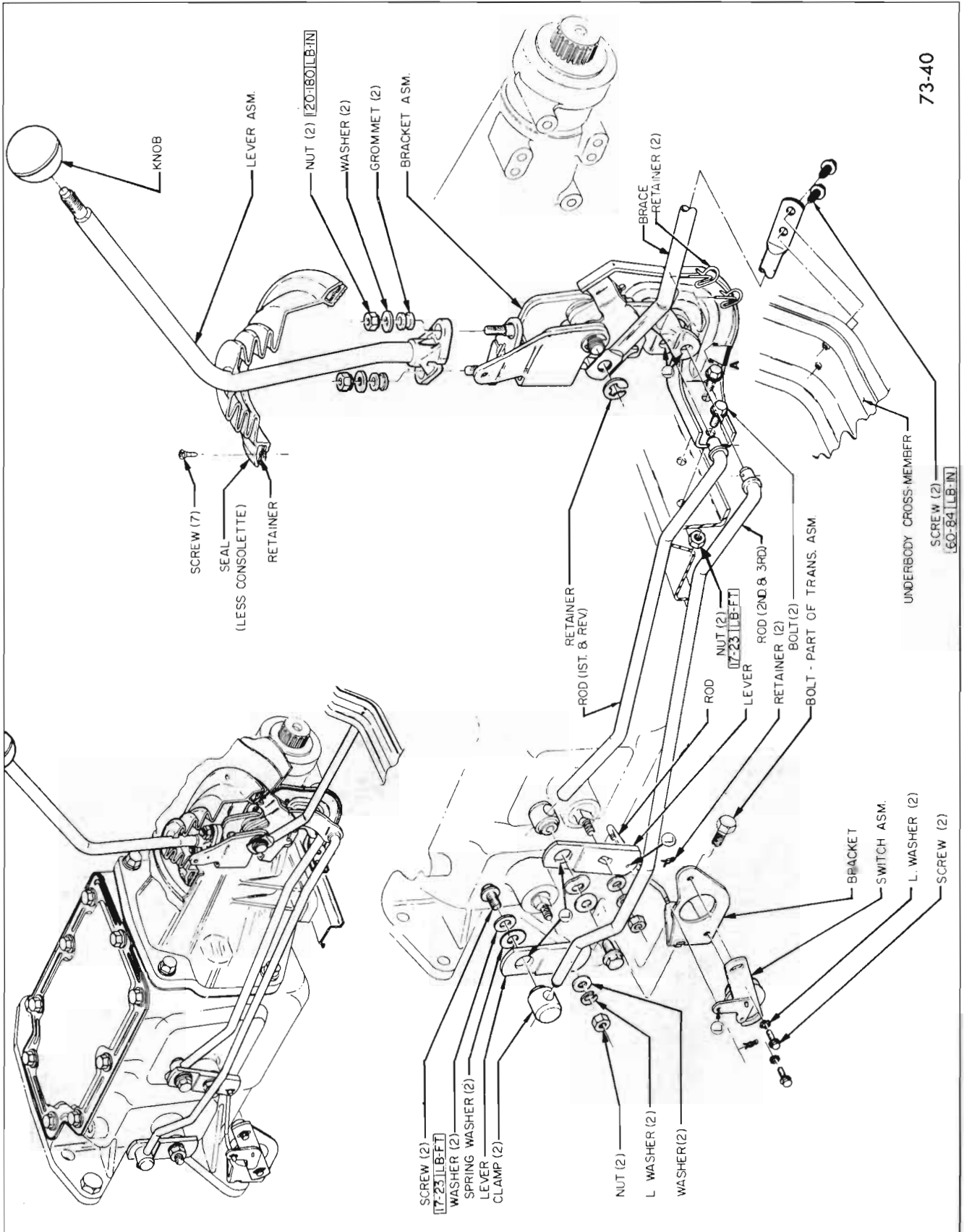

Figure 73-38



Figure 73-39





73-40

Figure 73-40

Figure 73-42

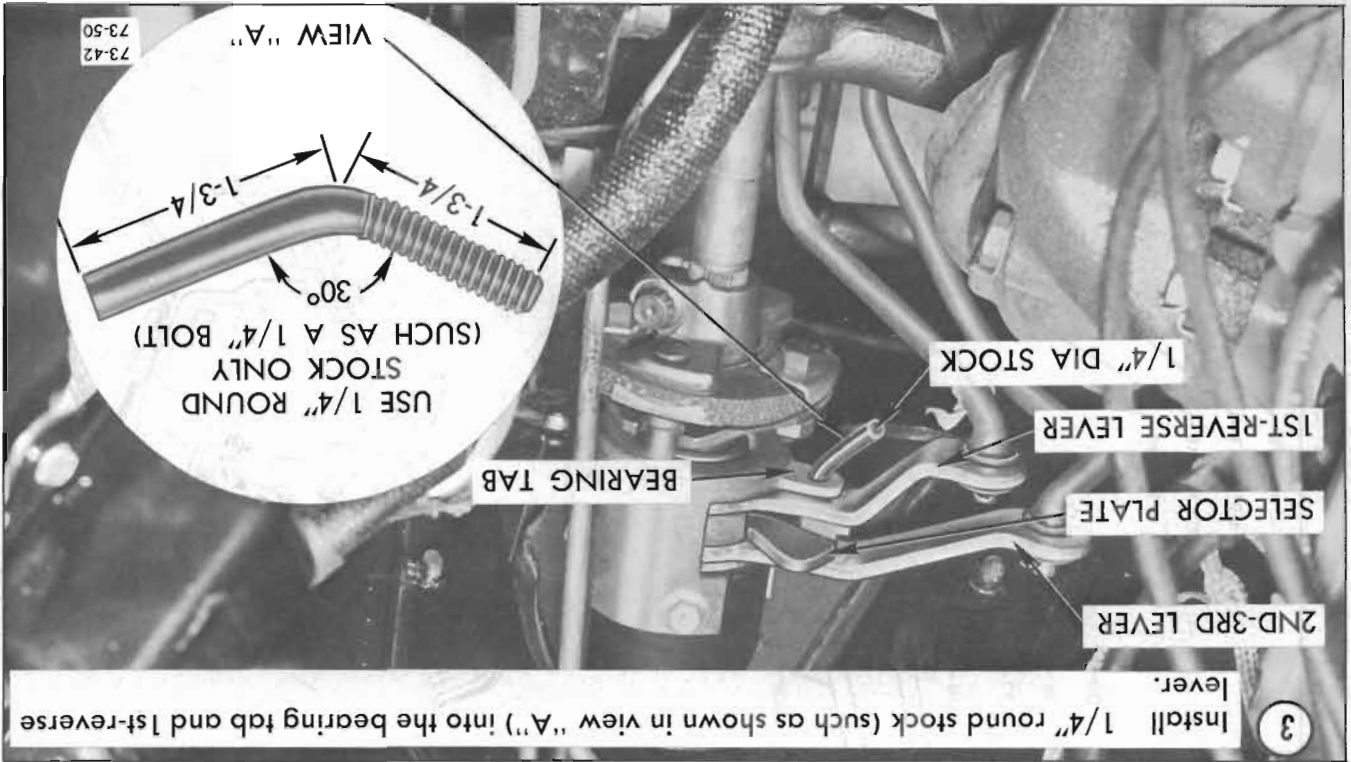
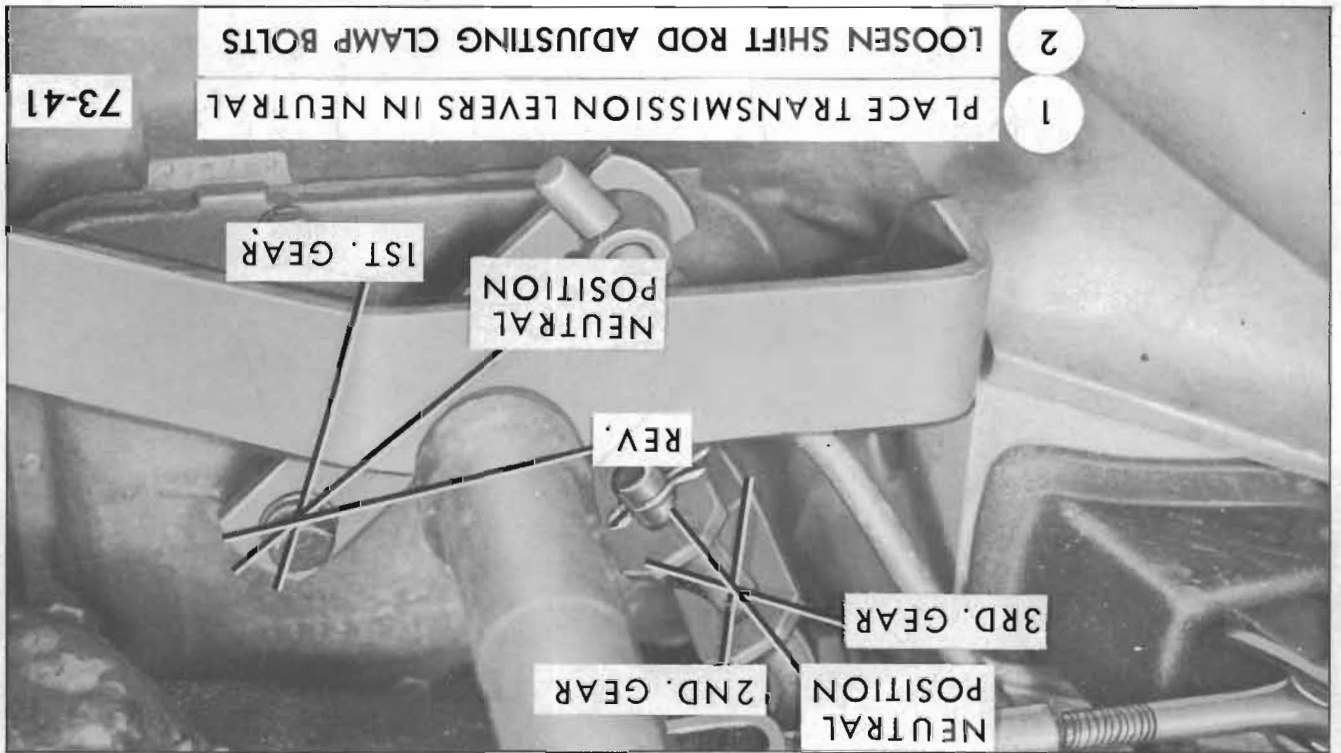

Figure 73-41



73-10 3-SPEED MANUAL TRANSMISSION SHIFT LINKAGE ADJUSTMENT (4500 SERIES)

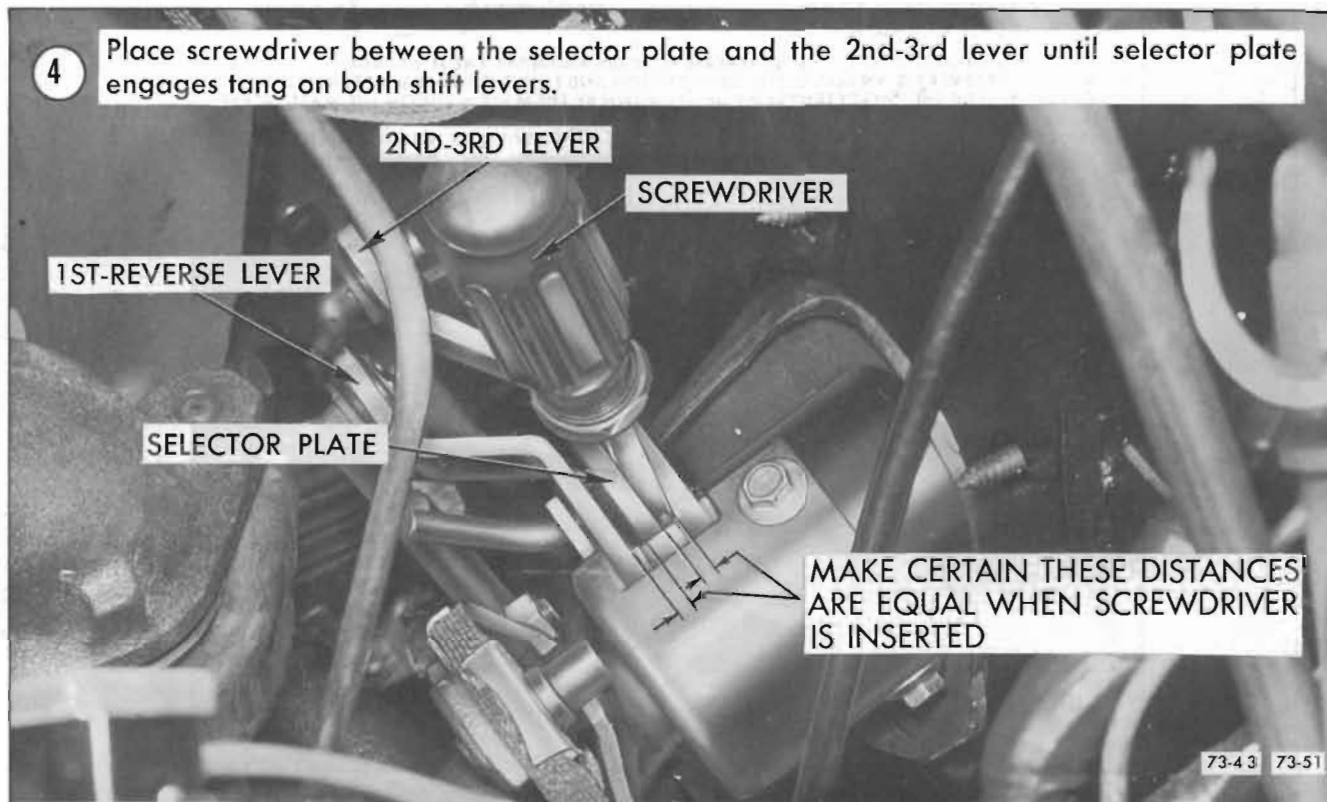

Figure 73-43

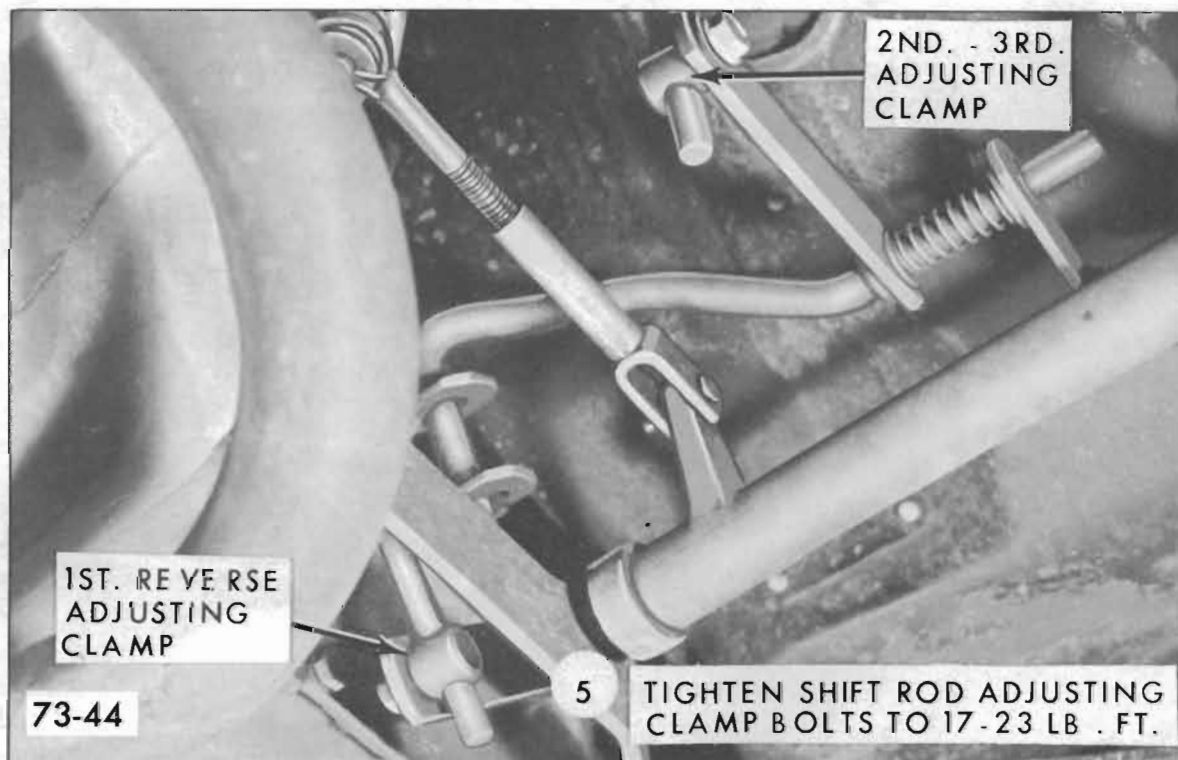

Figure 73-44

Figure 73-46

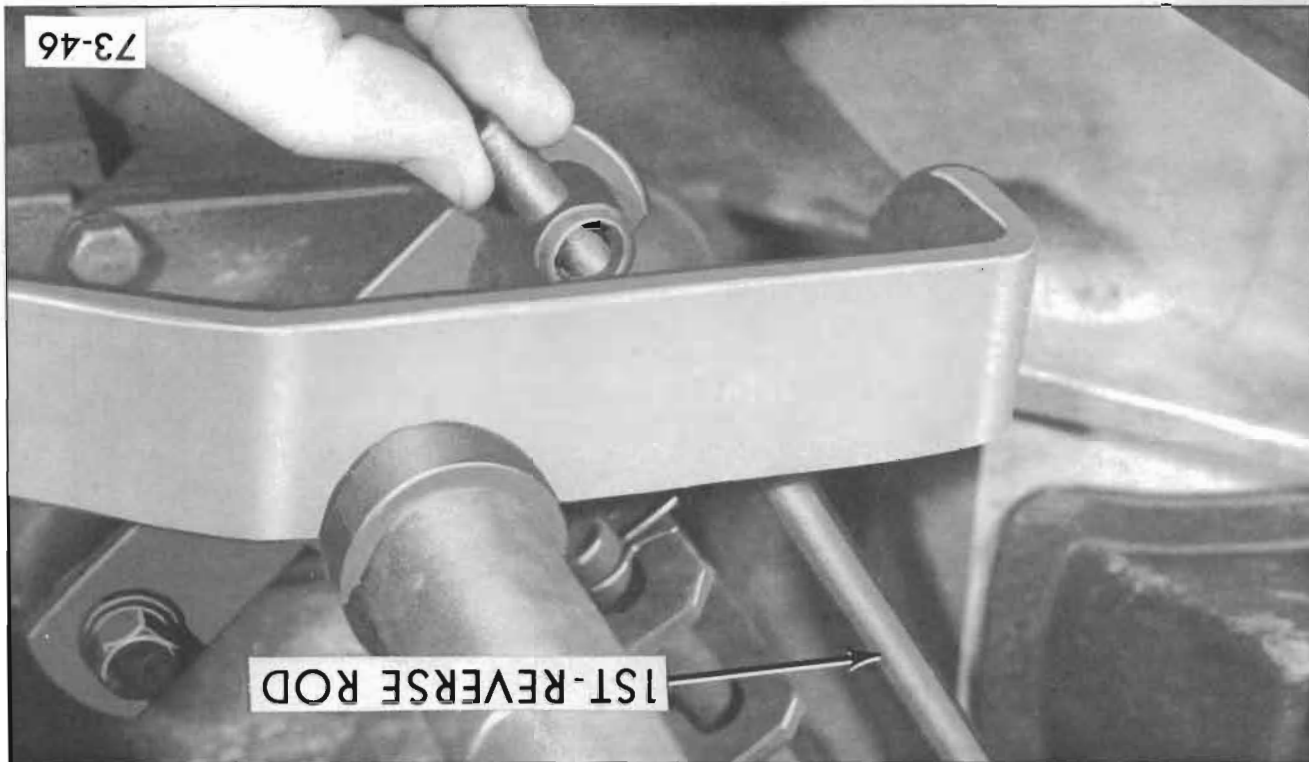
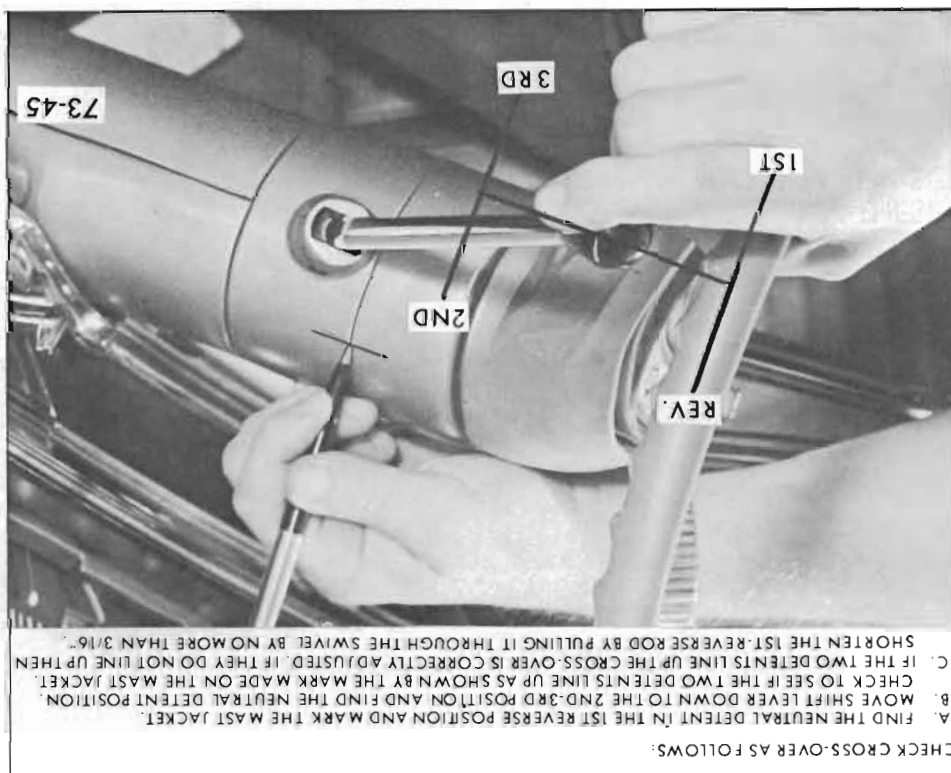

Figure 73-45



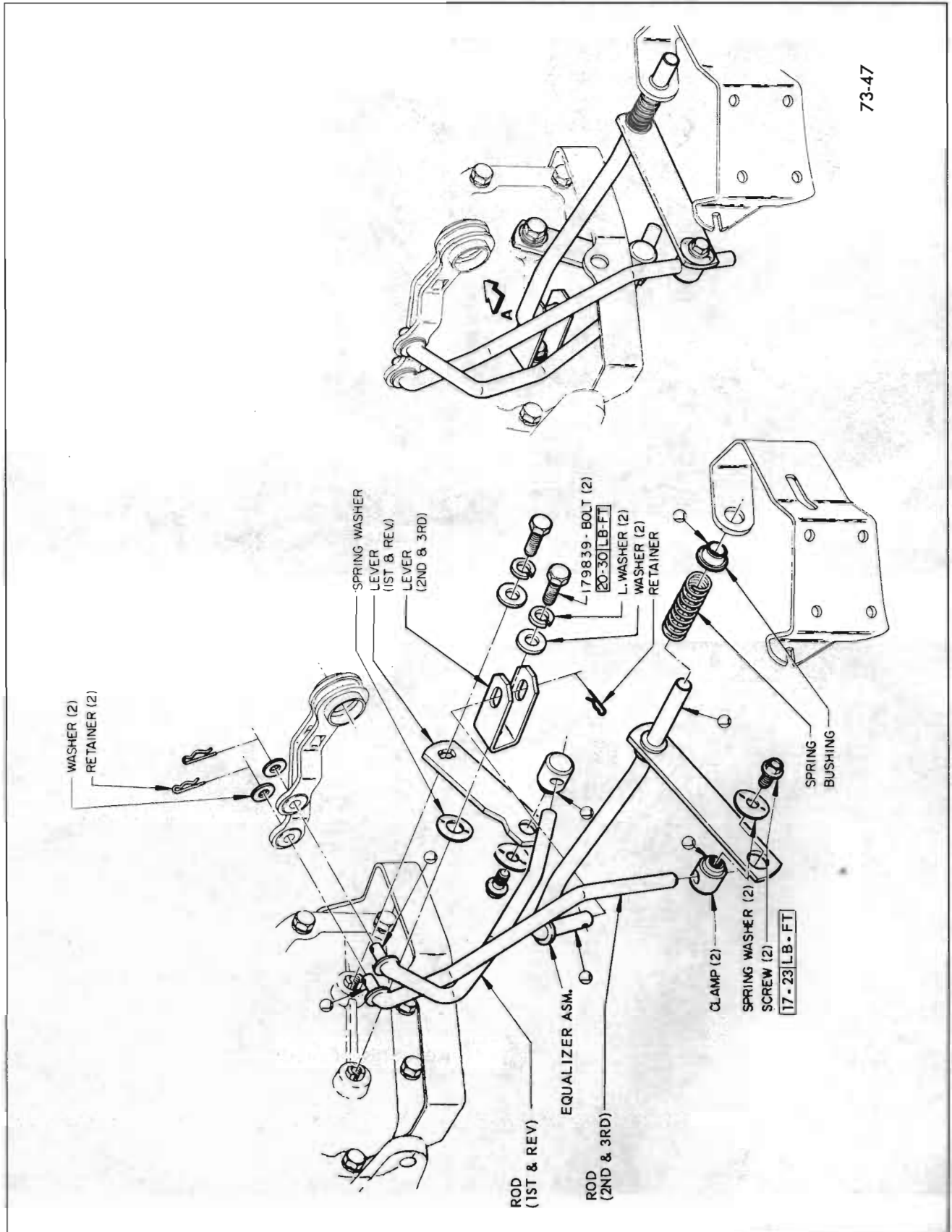

Figure 73-47

Figure 73-49

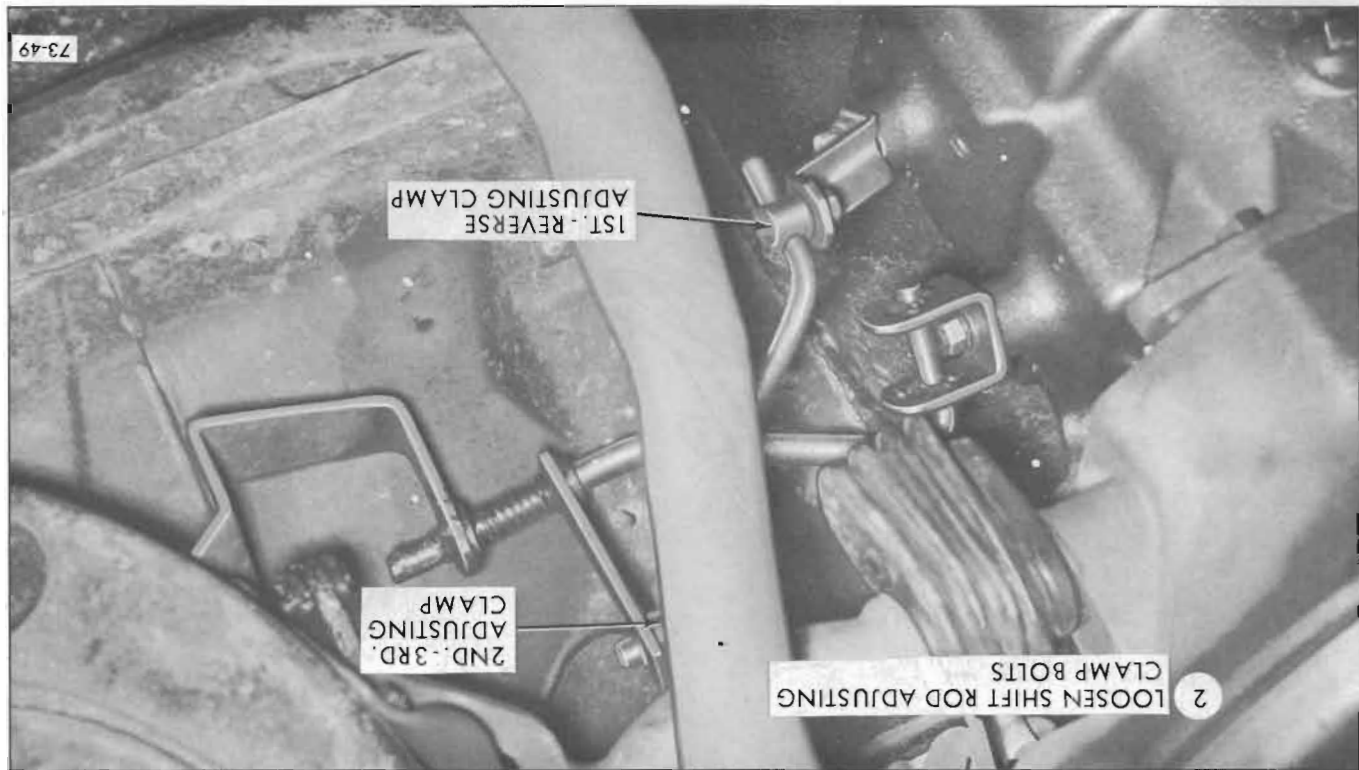
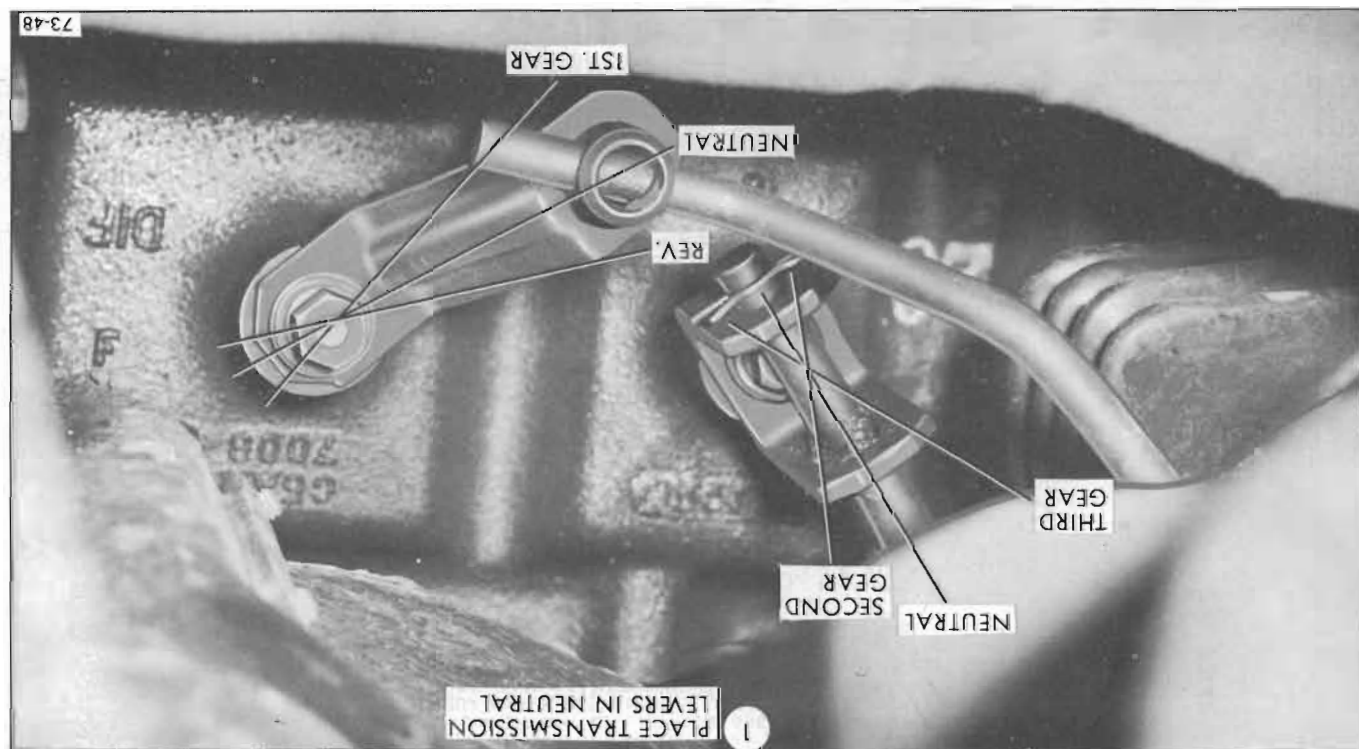

Figure 73-48



73-11 3-SPEED MANUAL TRANSMISSION SHIFT LINKAGE ADJUSTMENT (46000 SERIES)

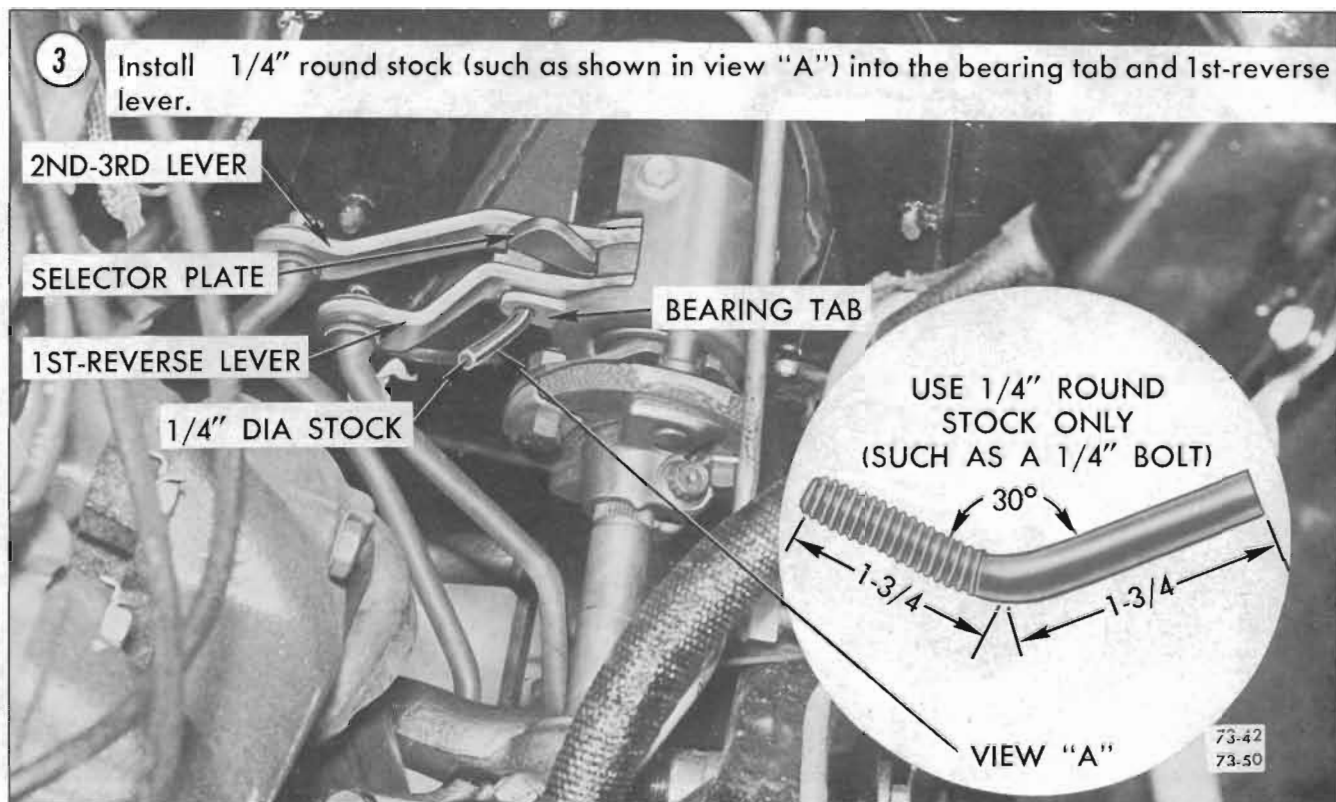

Figure 73-50

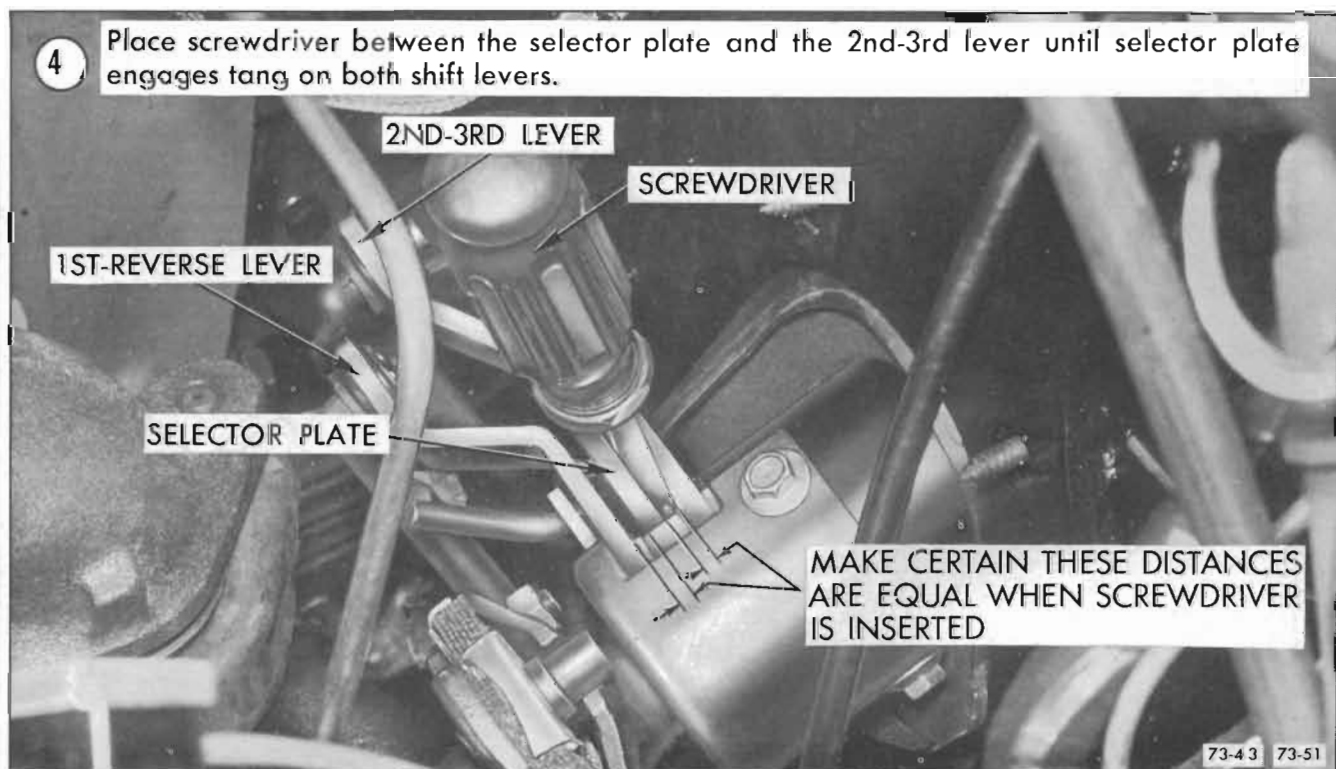
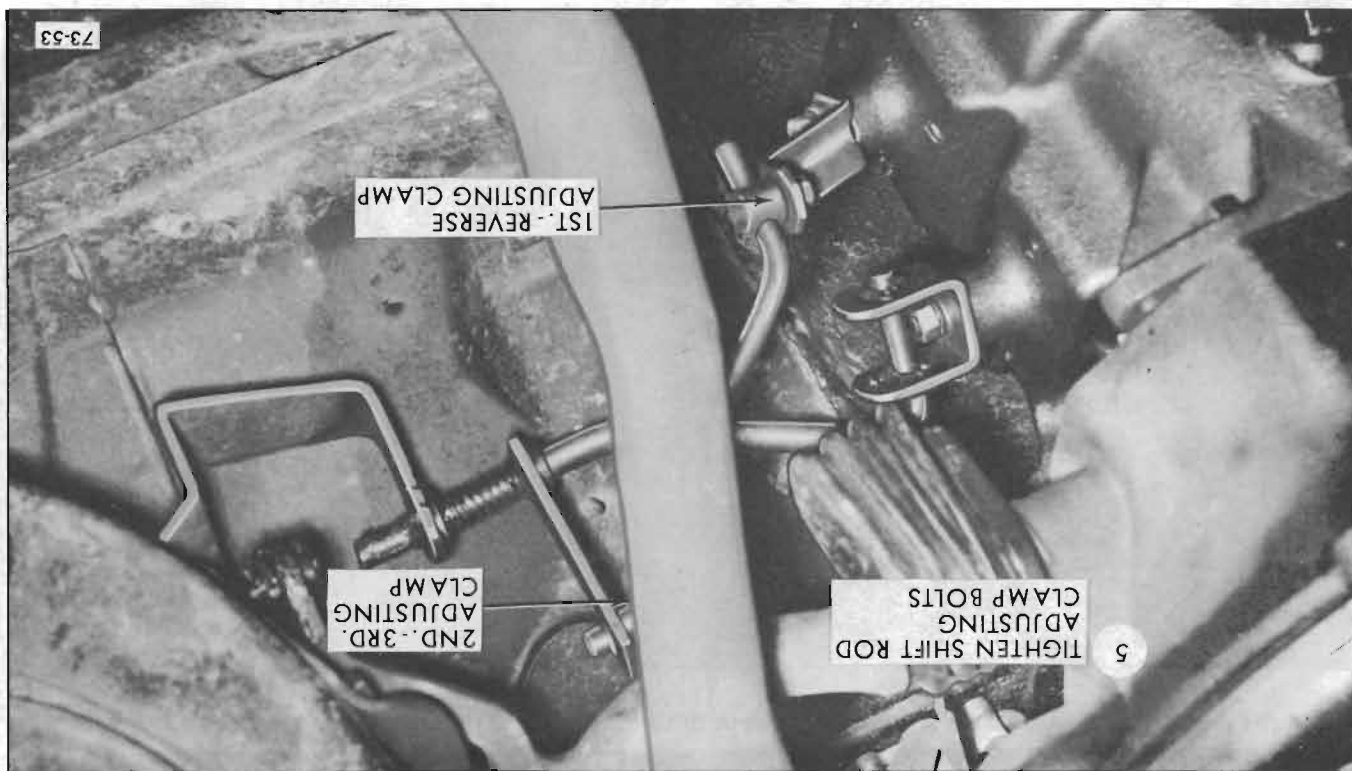

Figure 73-51

Figure 73-52



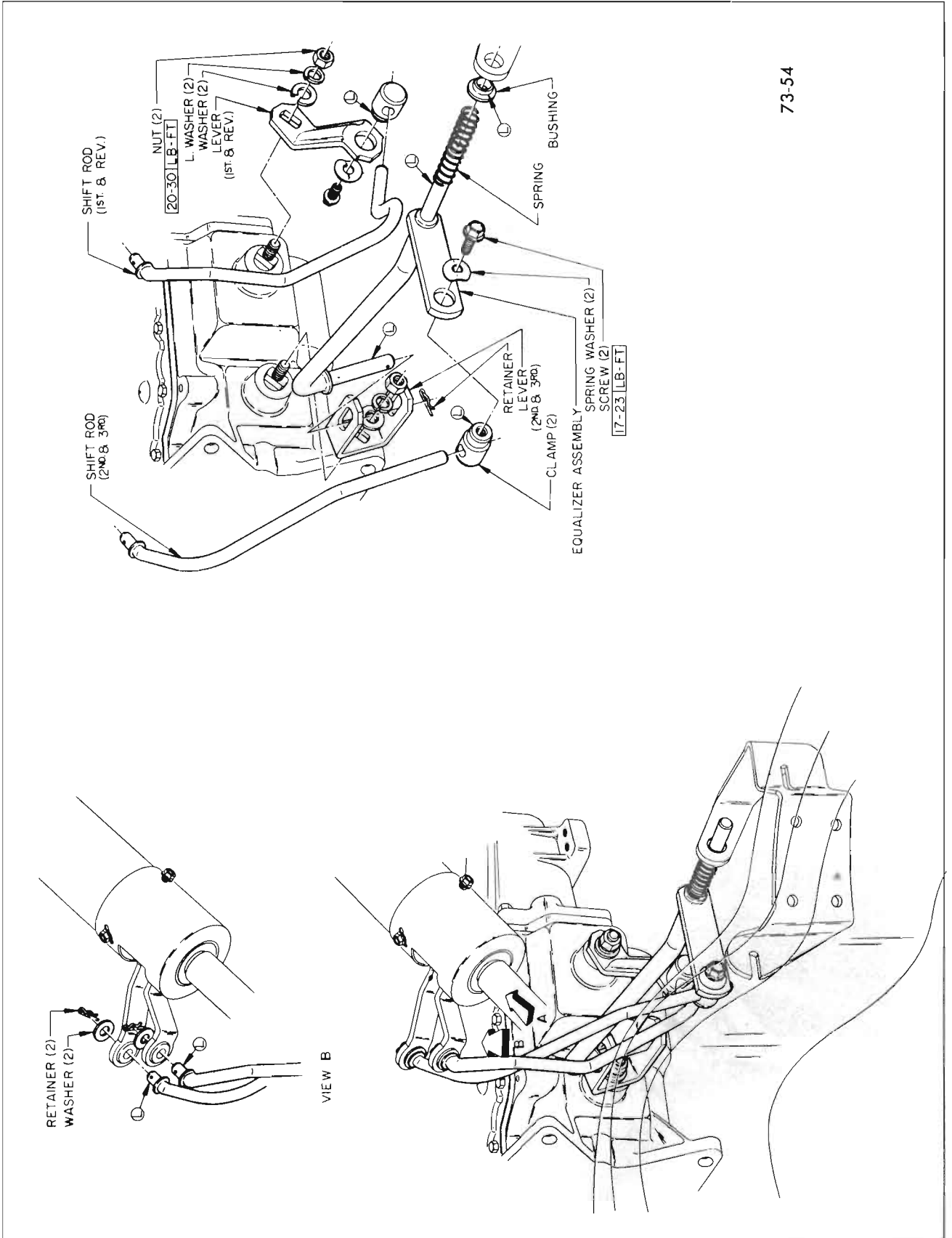

Figure 73-54

Figure 73-56

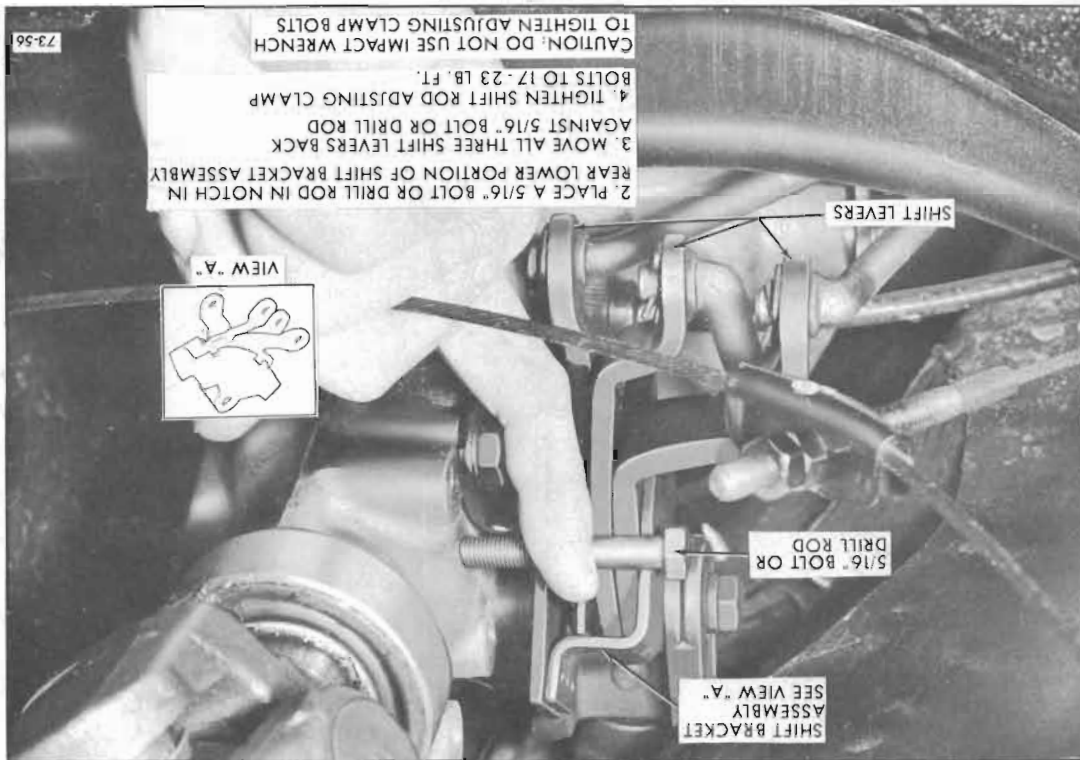
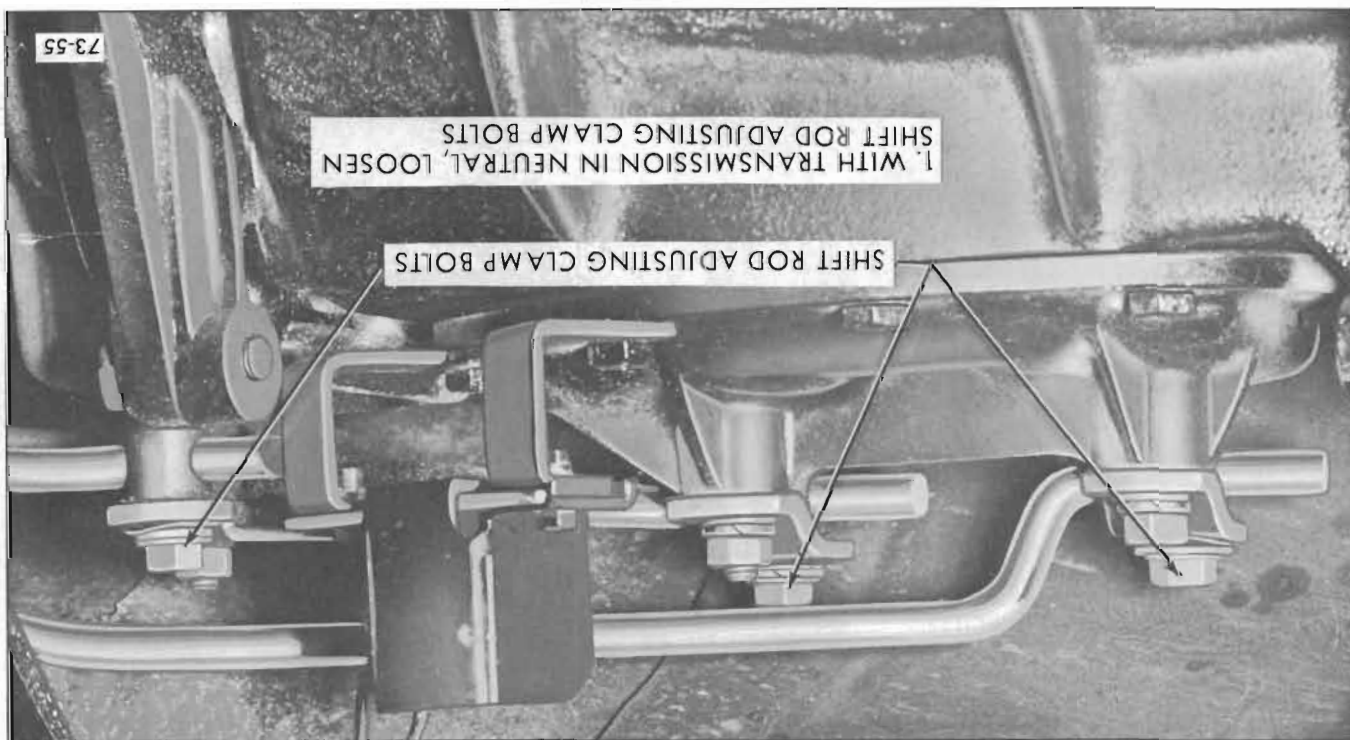

Figure 73-55



73-12 4-SPEED MANUAL TRANSMISSION SHIFT LINKAGE ADJUSTMENT (SKYLARK GRAN SPORT)

This "T" handle must travel a

minimum of 7/16"

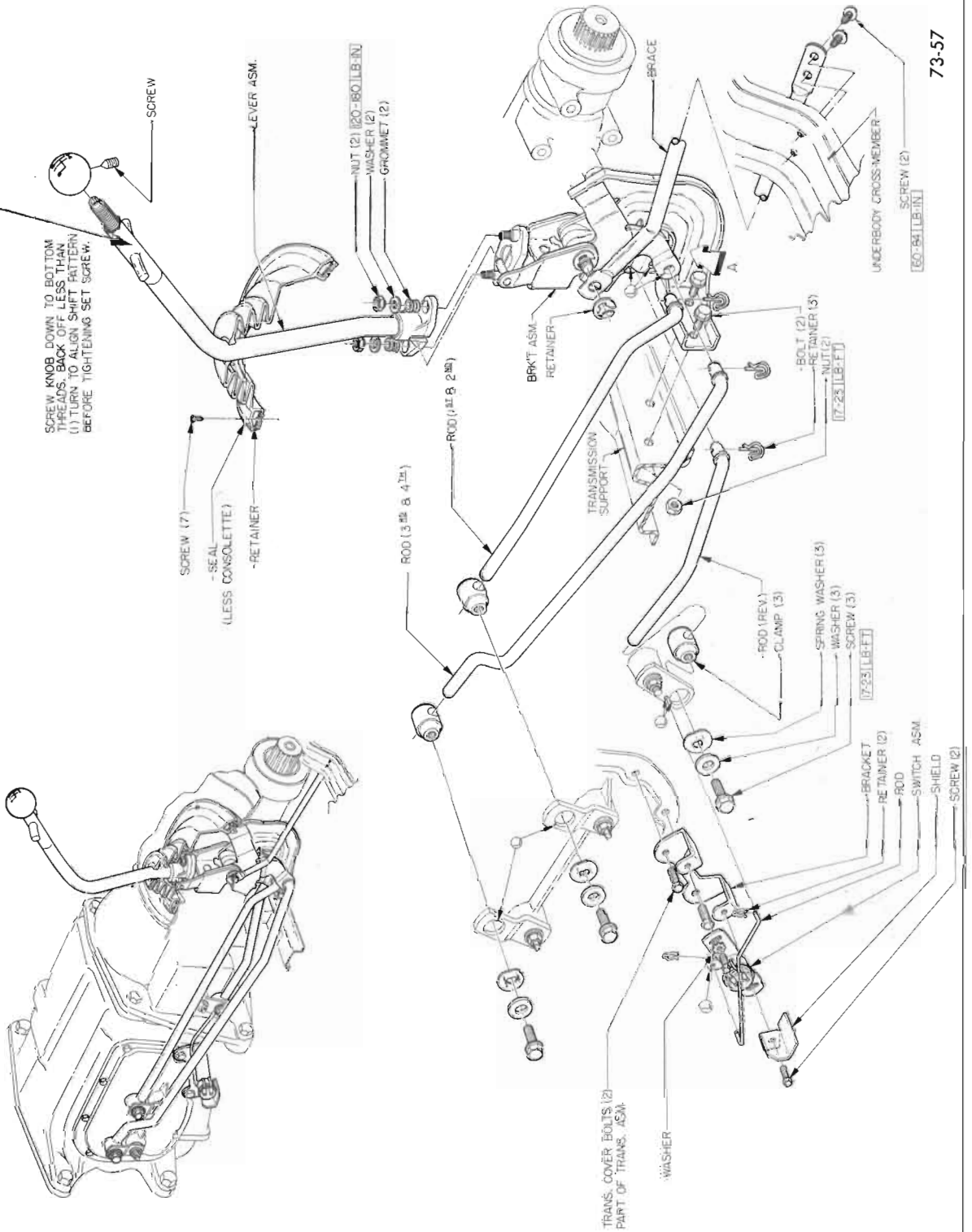

73-57

Figure 73-57