

SECTION B

THREE—SPEED MANUAL TRANSMISSION

SKYLARK GRAN SPORT AND WILDCAT

CONTENTS

Division	Paragraph	Subject	Page
I	72-1	SPECIFICATIONS AND ADJUSTMENTS: General Specifications	72-15
II	72-2	DESCRIPTION AND OPERATIONS: Description of the Three-Speed Manual Transmission	72-16
III	72-3 72-4 72-5 72-6 72-7 72-8	SERVICE PROCEDURES: Removal and Installation of Transmission Disassembly of Transmission Disassembly of Mainshaft Rear Bearing Retainer Seal and Bushing Shift Lever Shaft and Seal Replacement Reassembly of Transmission	72-18 72-18 72-20 72-21 72-22 72-22
IV	72-9	TROUBLE DIAGNOSIS: Trouble Diagnosis	72-25

DIVISION I

SPECIFICATIONS AND ADJUSTMENTS

72-1 GENERAL SPECIFICATIONS

a. Transmission Identification

A production code number is stamped on all Skylark Gran Sport and Wildcat three-speed manual transmissions. The number is located on the right front of the transmission. See Figure 72-200.

b. General Specifications

Type	All Forward Gears Synchronized
Mounting	Unit with Engine
Lubricant	
Type	SAE 80 or 80-90 Multi-Purpose
Capacity	3-1/2 Pints
Synchronization	1st, 2nd and 3rd
Gear Ratios	
1st	2.42 to 1
2nd	1.61 to 1
3rd	1.00 to 1
Reverse	2.33 to 1
Gear Shifting	On Steering Column
Speedometer Drive Gear	Press Fit

c. Bolt Tightening Specifications

Location	Torque Lb. Ft.
Rear Bearing Retainer to Case	42-50
Front Bearing Retainer to Case	19-25
Access Cover to Case	14-19
Filler Plug to Case.	20-30
Drain Plug to Case	20-30
Shift Fork to Shift Rail Set Screw	10-18

NOTE: These specifications are for clean and lubricated threads only. Dry or dirty threads produce increased friction which prevents accurate measurement. Use a reliable torque wrench to tighten the attaching bolts for the above listed parts.

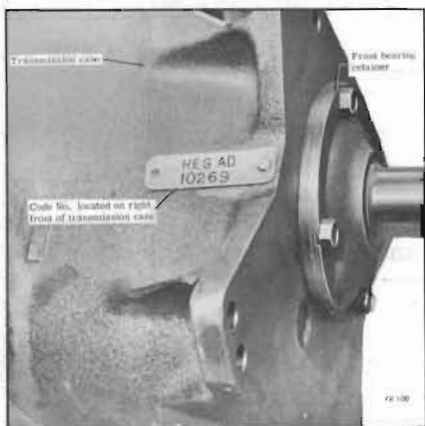

Figure 72-200—Transmission Code Number

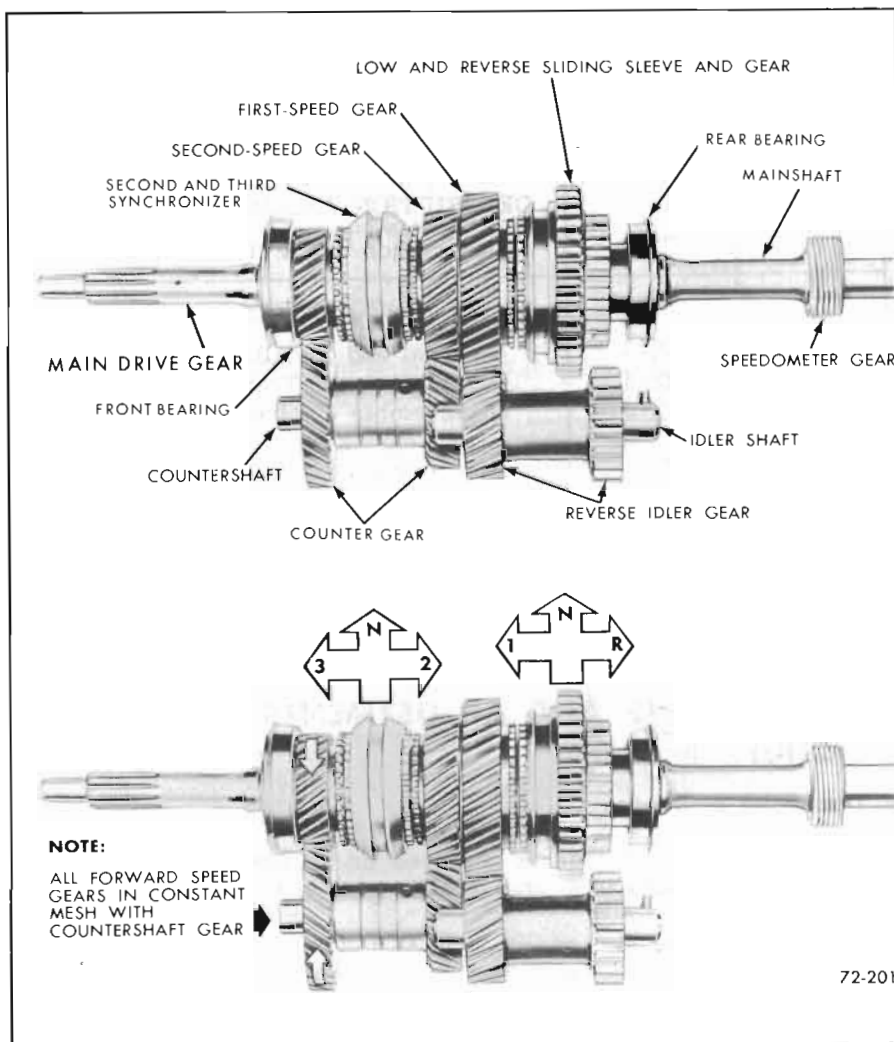

Figure 72-201—Gear Synchronizers

**DIVISION II
DESCRIPTION
AND OPERATION**

**72-2 DESCRIPTION OF THE THREE-SPEED
MANUAL TRANSMISSION**

The Skylark Gran Sport and Wildcat models will have as standard equipment a 3-speed manually operated transmission with all forward gears synchronized. All forward-speed changes are accomplished with synchronizer sleeves. See Figure 70-201. The synchronizers permit quicker shifts, greatly reduce gear clash, and permit down-shifting from

third to second between 40-20 MPH and from second to first below 20 MPH. Power flow in all gears is shown in Figure 72-202.

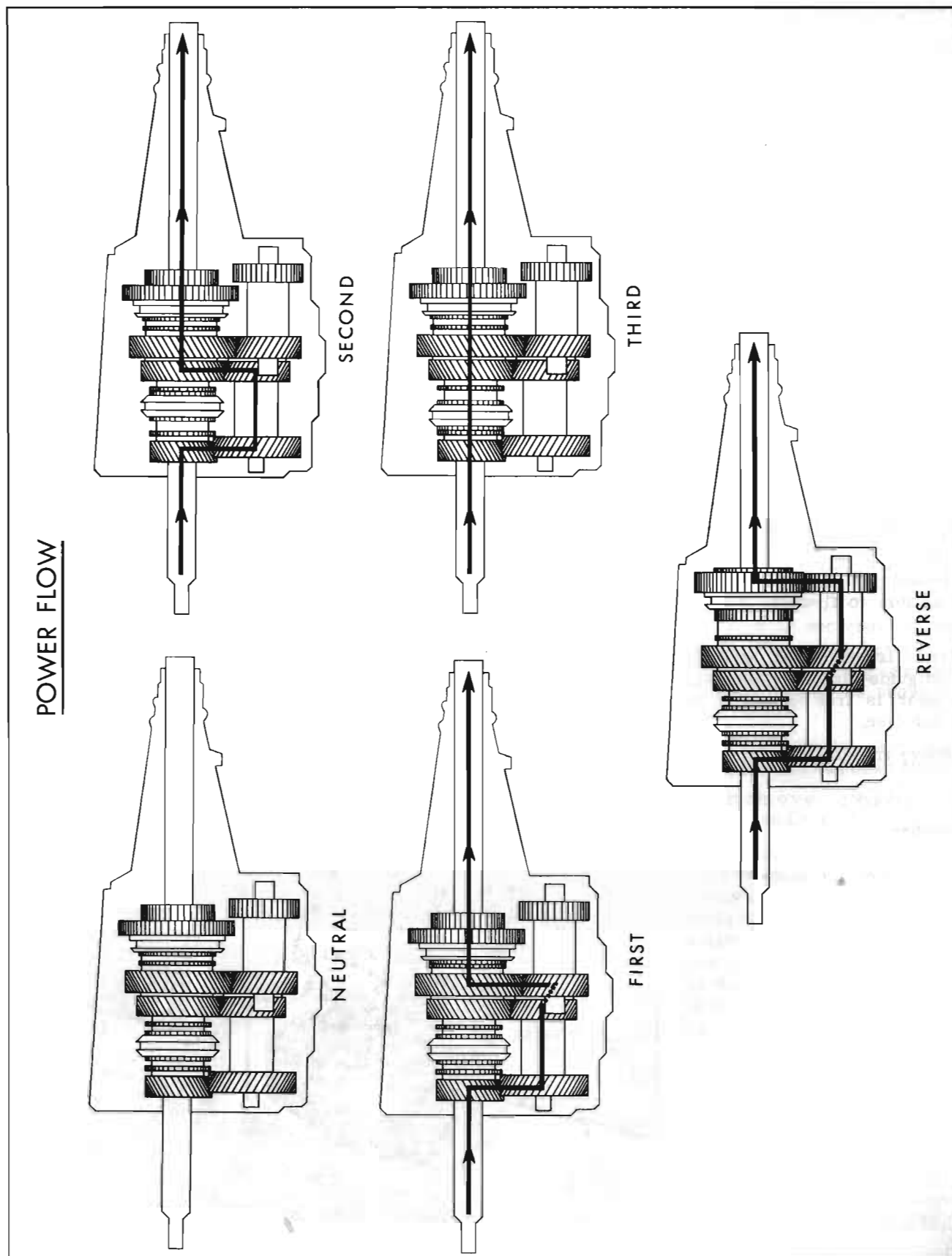

Figure 72-202—Power Flow

DIVISION III

SERVICE PROCEDURES

72-3 REMOVAL AND INSTALLATION OF TRANSMISSION

a. Removal

1. Disconnect speedometer cable and remove speedometer driven gear and sleeve assembly.
2. Disconnect shift control rods from transmission.
3. Remove propeller shaft.
4. Support rear of engine and remove transmission support.
5. Remove the two (2) top transmission to flywheel housing bolts and insert guide pins.

NOTE: If guide pins are not used damage to the clutch friction plate can result.

6. Remove the two (2) lower transmission to flywheel housing bolts.
7. Slide transmission straight back on guide pins until the main drive gear is free of splines in the clutch disc.
8. Remove transmission.

b. Installation

1. Install guide pin in lower right transmission to clutch housing bolt hole for alignment and place transmission on guide pin. Place transmission in third gear and rotate transmission mainshaft as necessary to start main drive gear into clutch disc. Slide transmission forward.

NOTE: If guide pin is not used damage to the clutch plate can result.

2. Install two (2) lower transmission mounting bolts. Remove guide pin and install two upper bolts. Torque bolts to 45 to 60 lb. ft.

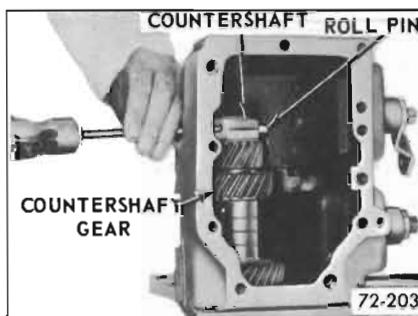

Figure 72-203—Removing Countergear Shaft Retaining Pin

3. Install transmission support.
4. Install propeller shaft.
5. Install speedometer driven gear and sleeve assembly. Connect speedometer cable.
6. Connect linkage and adjust as described in Section 73.

72-4 DISASSEMBLY OF TRANSMISSION

1. Drain lubricant.
2. Remove front bearing retainer and gasket.
3. Remove access cover and gasket.
4. Remove rear bearing retainer housing and gasket.

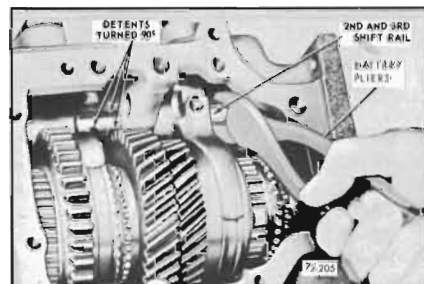

Figure 72-205—Rotating 2nd - 3rd Shift Rail

5. Through filler plug hole drive out countershaft to case retaining pin. See Figure 72-203.
6. Remove set screw, spring, interlock plug, detent plugs, and spring. See Figure 72-204.
7. With transmission in neutral, remove shift fork to rail locking screws. See Figure 72-204.
8. Remove first - reverse shift rail from rear of case.
9. Using battery pliers with jaws padded, rotate second-third shift rail 90°. See Figure 72-205.

NOTE: Rail must be rotated 90° to disengage detent plunger.

10. Using brass drift, drive second-third shift rail and expansion plug out front of case.

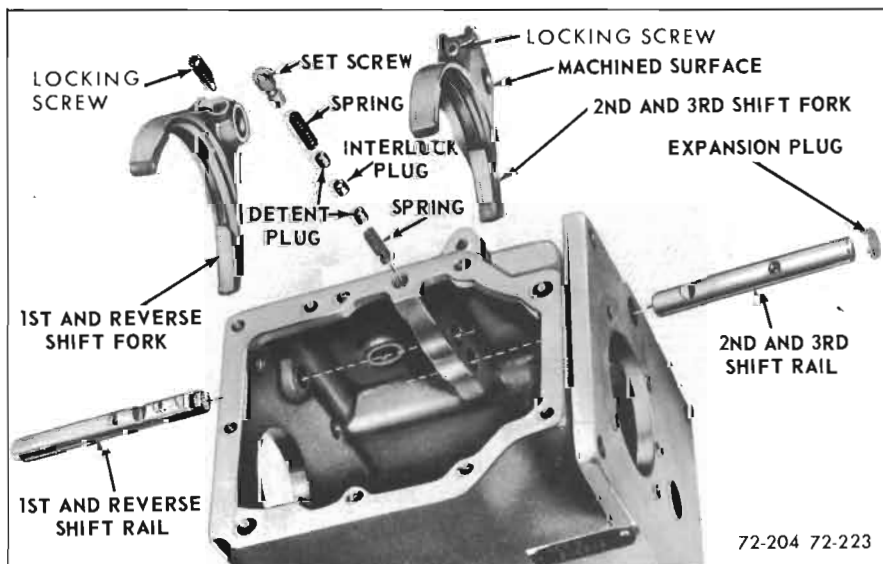

Figure 72-204—Shift Rails, Forks, and Detent Plugs

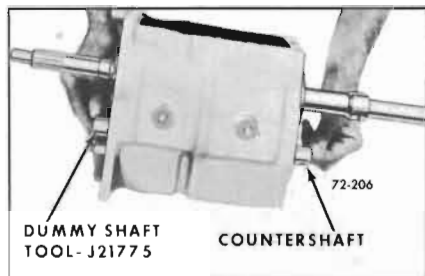

Figure 72-206—Removing Countershaft With J-21775

11. Using countershaft alignment Tool J-21775, drive countershaft out rear of case. See Figure 72-206.

NOTE: Insert screwdriver through filler plug hole. Locate it between the case and countergear to prevent countergear from dropping to bottom of case. After removing countershaft, carefully lower counter-

gear to bottom of case by removing screwdriver.

12. Remove speedometer drive gear snap ring, drive gear, and retaining ball.

13. Remove mainshaft to rear bearing snap ring.

14. Remove large snap ring from rear bearing.

15. Remove rear bearing as follows: See Figure 72-207.

a. Slide Tool J-21774-1 over bearing and install snap ring in outer race of bearing.

b. Install speedometer drive gear snap ring on mainshaft.

c. Install J-21774-5 into J-21774-2.

d. Slide Tool J-21774-2 onto mainshaft and thread into J-21774-1.

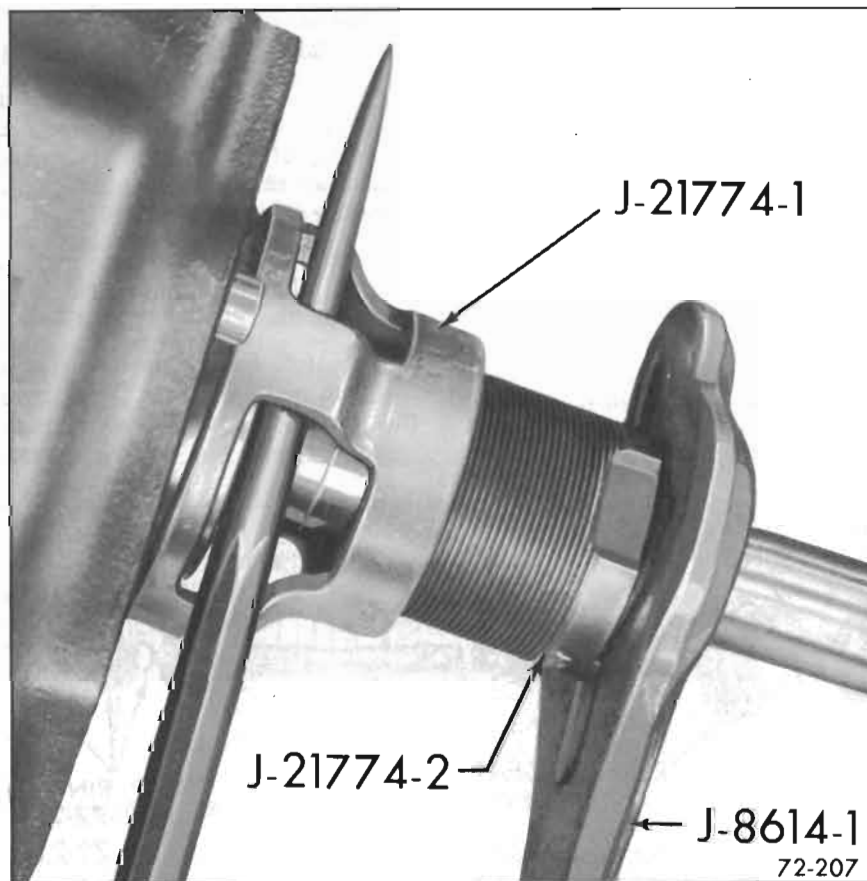

Figure 72-207—Removing Rear Bearing

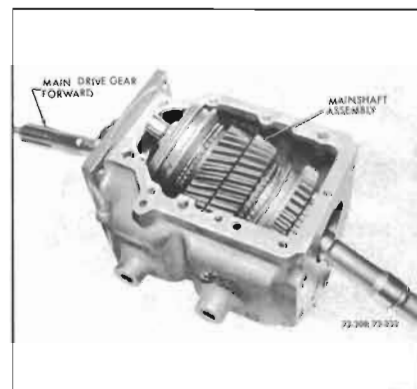

Figure 72-208—Removing Mainshaft Assembly

e. Thread J-21774-2 into J-21774-1 with J-8614-1 until bearing is free of mainshaft.

16. Slide main drive gear forward until it rests against case.

17. Remove shift forks.

18. Remove mainshaft assembly through top of case. See Figure 72-208.

19. If it is necessary to remove main drive gear bearing, use a soft hammer, tap gear down through bearing as shown in Figure 72-209.

20. From inside case, tap out front bearing and snap ring.

21. Remove countergear and thrust washers.

22. Using a brass drift, drive reverse idle gear shaft out rear

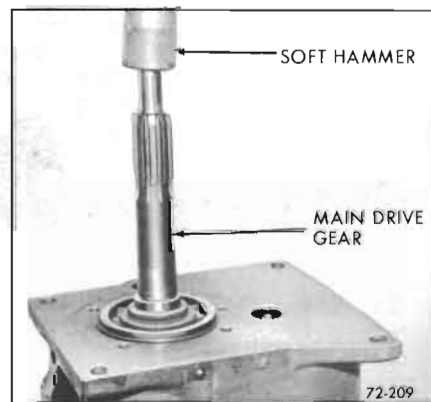

Figure 72-209—Removing Front Bearing

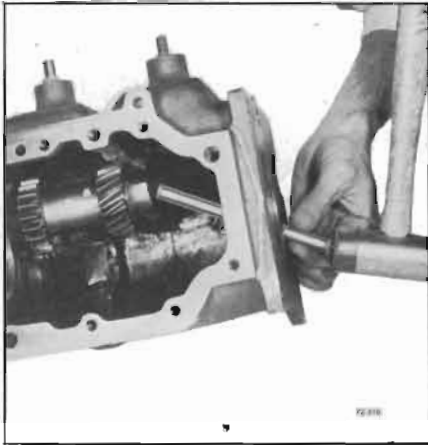

Figure 72-210—Removing Reserve Idle Gear

of case. See Figure 72-210. Remove gear from case.

72-5 DISASSEMBLY OF MAINSHAFT (See Figure 72-211)

1. Remove third speed blocking ring.
2. Remove mainshaft to second-third synchronizer snap ring.
3. Remove second-third synchronizer assembly and second speed blocking ring.
4. Remove second speed gear.
5. Remove first gear snap ring, thrust washer, first speed gear, and blocking ring.
6. Remove reverse gear retaining snap ring, gear and sleeve assembly.
7. Mark first-reverse synchro-

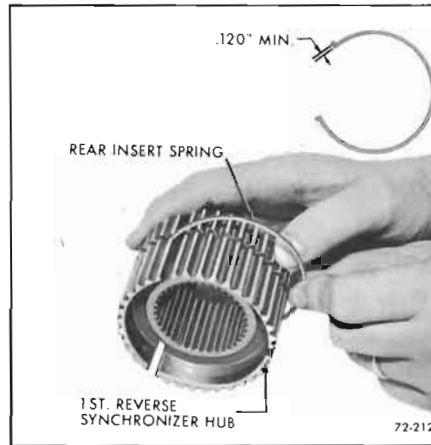

Figure 72-212—Installing Rear Insert Spring

nizer hub and gear so it can be assembled in the same position.

8. Remove first-reverse gear synchronizer hub, insert springs, and inserts.

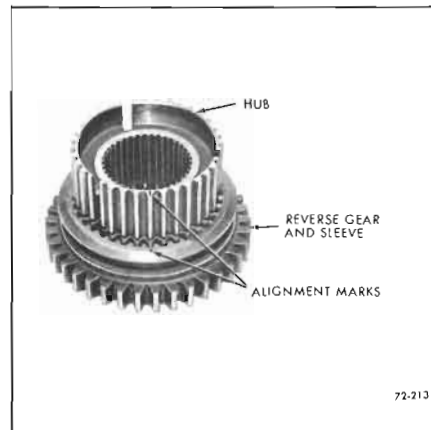

Figure 72-213—Starting Hub into Gear

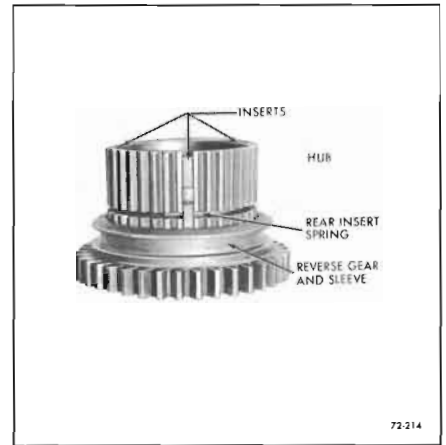

Figure 72-214—Positioning Inserts

9. Clean and inspect all parts except countergear.

10. Disassemble, clean and inspect countergear and rollers.

a. Assembly

1. Install rear insert spring in groove in first-reverse synchronizer hub. See Figure 72-212.

NOTE: Make certain spring covers all insert grooves. If the tip of the rear insert spring is less than .120 inch in length, replace spring.

2. Start hub in sleeve making sure alignment marks are indexed. See Figure 72-213.

3. Position the three inserts in the hub with the small end over the spring and the shoulder on inside of hub. See Figure 72-214.

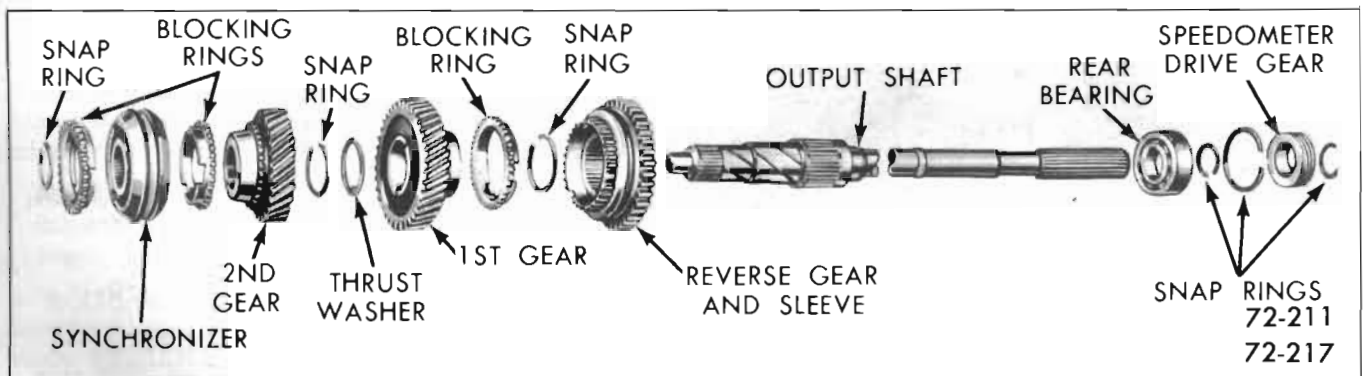

Figure 72-211—Exploded View of Mainshaft

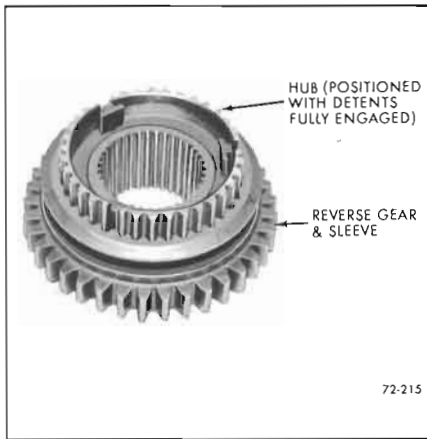

Figure 72-215—Sliding Sleeve into Hub

4. Slide sleeve onto hub until the detent is engaged. See Figure 72-215.

5. Install front insert spring in hub as shown in Figure 72-216.

6. Lubricate mainshaft splines and machined surfaces with transmission lubricant.

7. Slide the first-reverse gear and sleeve assembly onto mainshaft with teeth of gear facing toward rear of shaft secure with snap ring. See Figure 72-217.

8. Coat tapered machine surface on first speed gear with grease. Place blocking ring on greased surface. See Figure 72-217.

9. Slide first speed gear onto mainshaft with blocking ring toward rear of shaft. Rotate gear as necessary to engage three

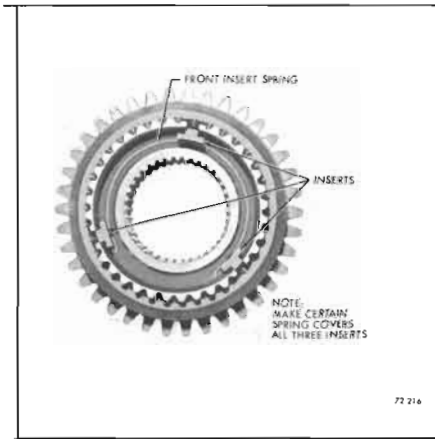

Figure 72-216—Installing Front Insert Spring

notches in blocking ring with synchronizer inserts. See Figure 72-217.

10. Secure first gear with thrust washer and snap ring.

11. Coat tapered machine surface of second speed gear with grease and slide blocking ring onto it.

12. Assemble second-third speed synchronizer as follows:

a. Install insert spring into groove of second-third speed synchronizer hub.

NOTE: Make certain that all three insert slots are fully covered. See Figure 72-218.

b. With alignment marks on hub and sleeve aligned, start hub onto sleeve. See Figure 72-218.

c. Place three inserts, in the slots, on top of retaining spring. See Figure 72-218. Push assembly together.

d. Install remaining insert spring so that spring ends cover same slots as does other spring. See Figure 72-218.

13. Slide second speed gear with blocking ring and second-third speed gear synchronizer onto mainshaft. Tapered machine surface of second speed gear must be toward the front of shaft. See Figure 72-217.

NOTE: Make certain notches in blocking ring engage the synchronizer inserts.

14. Secure synchronizer with snap ring.

72-6 REAR BEARING RETAINER SEAL AND BUSHING REMOVAL AND INSTALLATION

a. Removal

1. Using J-2619 Slide Hammer and J-4830-02 puller, remove rear bearing retainer oil seal.

2. Using J-2619 slide hammer and J-4830-02 puller, remove rear bearing retainer bushing.

b. Installation

1. Install rear bearing retainer bushing using Tool J-6403-1.

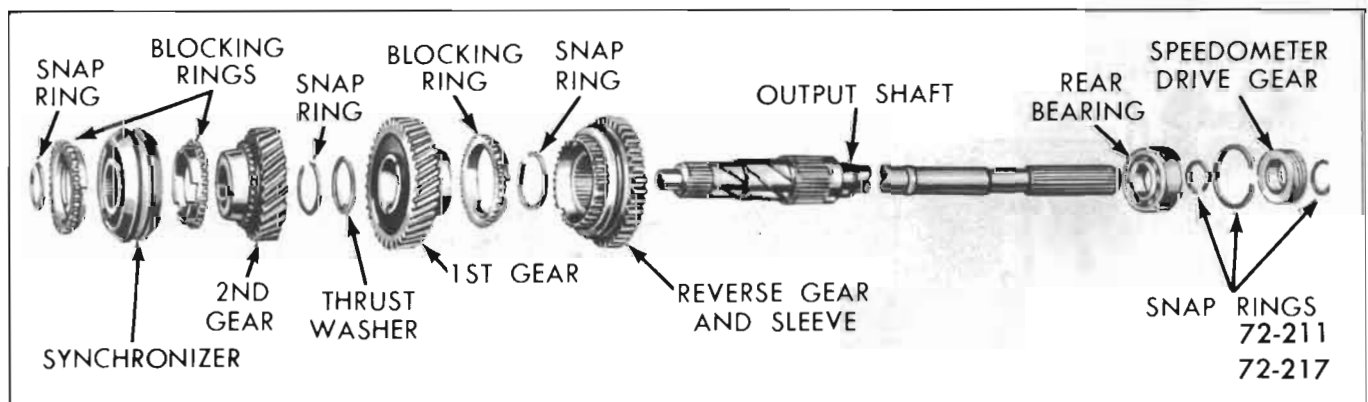

Figure 72-217—Mainshaft Exploded

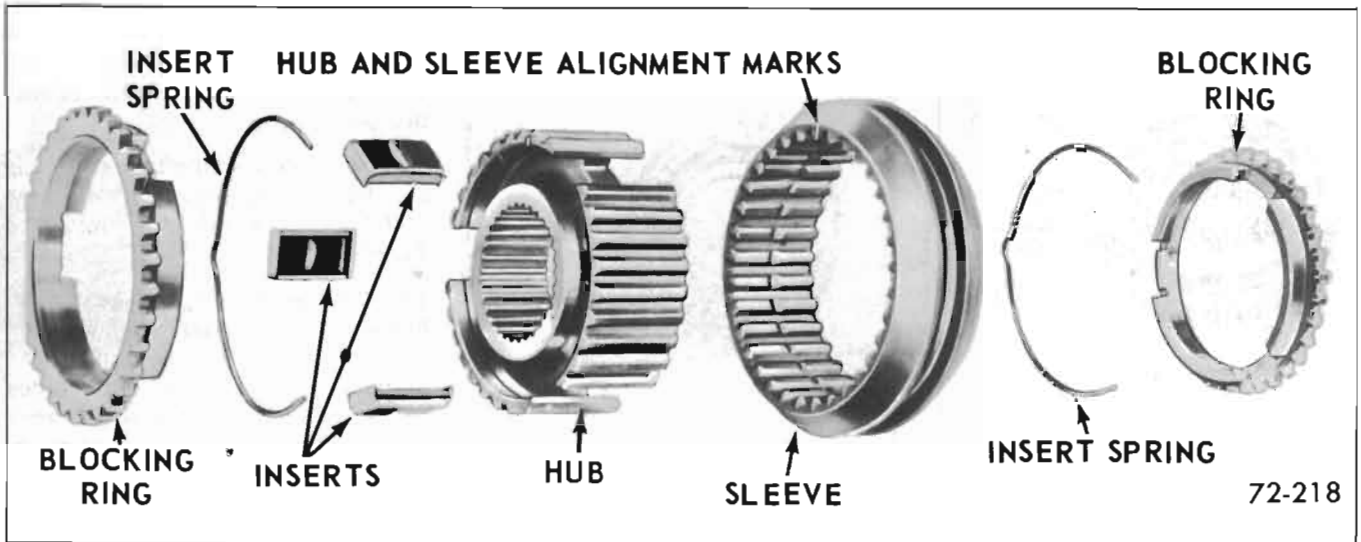

Figure 72-218—Exploded View of Second-Third Synchronizer

2. Install rear bearing retainer oil seal as follows:

a. Install J-6403-2 onto J-6403-1.

NOTE: Flat side of J-6403-2 must be toward rear of J-6403-1.

b. Install oil seal.

72-7 SHIFT LEVER SHAFT AND SEAL REPLACEMENT

1. Remove nut, lock washer, flat washer and shift lever from the first-reverse and second and third shift lever shaft.

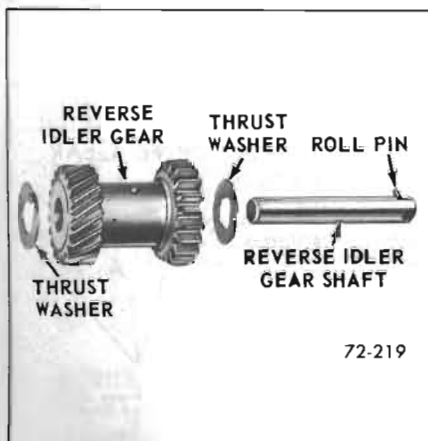

Figure 72-219—Exploded View of Reverse Idler Gear

2. From inside case, slide out shift lever shaft.

3. Remove and discard "O" ring seal.

4. Lubricate new seal and install.

5. Install shaft into case.

6. Install shift lever and secure flat washer, lock washer, and nut.

72-8 REASSEMBLY OF TRANSMISSION

1. Install reverse idler gear, with a thrust washer on each end in case. Make certain that roll pin is seated in slot in back face of case. See Figure 72-219.

2. Assemble the countergear alignment Tool J-21775, bearings, thrust washers, and place in bottom of case. The countergear will

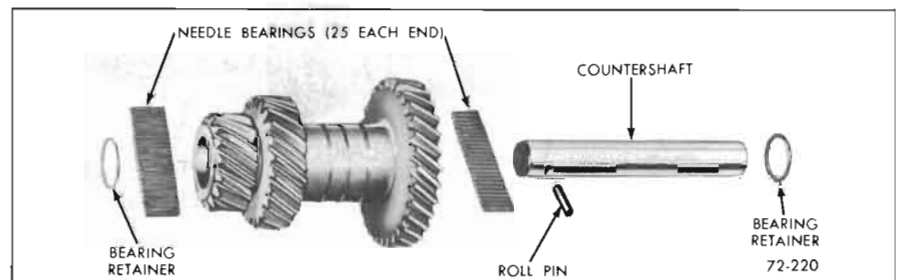

Figure 72-220—Exploded View of Countergear

remain in the bottom of the case until the mainshaft and main drive gear have been installed. See Figure 72-220.

3. If main drive gear bearing was removed, replace as follows:

a. Press bearing onto main drive gear (snap ring groove to front). See Figure 72-221. Be certain bearing fully seats against shoulder on gear.

4. Coat bore of main drive gear with a thin film of grease.

NOTE: A thick film of grease will plug lubricant holes and prevent lubrication of bearings. Install the 15 needle bearings in bore.

5. Install main drive gear and bearing through top of case into bore in front of case. Install large snap ring on bearing.



Figure 72-221—Installing Main Drive Gear Bearing

6. Position mainshaft assembly in case. See Figure 72-222.

7. Install second-third speed shift fork on second-third speed synchronizer.

8. Place a detent plug spring and detent plug in case.

9. Place second and third speed synchronizer in second speed position (toward rear of case).

10. Align shift fork and install second and third speed shift rail.

NOTE: It will be necessary to depress detent plug to install rail in the bore. Move rail in until detent plug engages forward notch.

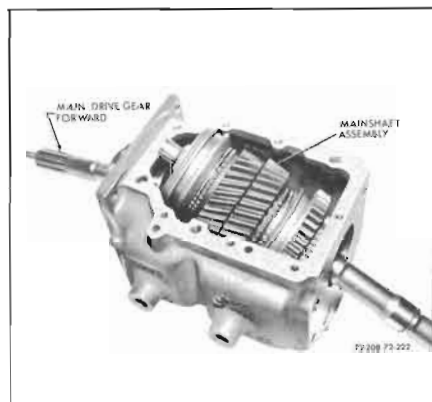

Figure 72-222—Installing Mainshaft

11. Secure shift fork to shift rail with set screw.

12. Move synchronizer to neutral position.

13. Install interlock plug in case. If second and third speed shift rail is in neutral position, top of interlock will be slightly lower than surface of first and reverse shift rail bore. See Figure 72-223.

14. Move first and reverse synchronizer forward and place first

and reverse shift fork in groove of synchronizer.

15. Align fork and install first and reverse shift rail. Move rail in until center notch is aligned with detent bore.

16. Install remaining detent plug and spring. Secure spring with slotted head set screw. Turn screw in until head is flush with case.

17. Secure shift fork to shift rail with set screw torque 10-18 lb. ft.

18. Install a new shift rail expansion plug in front of case.

19. While holding main drive gear and blocking ring in position, move mainshaft forward to seat the mainshaft pilot in roller bearings of input shaft.

20. Tap front bearing into place in case while holding mainshaft to prevent roller bearings from dropping out.

21. Install front bearing retainer, and new gasket, making sure the oil return slot is toward bottom of case. Torque attaching bolts to 19-25 lb. ft.

NOTE: If front bearing retainer seal was removed proceed as follows:

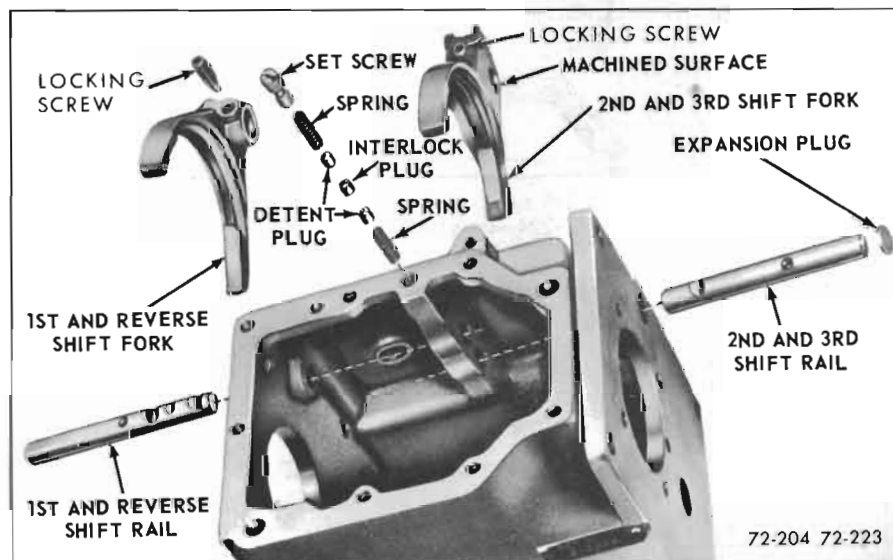

Figure 72-223—Shift Rails, Fork and Detent Plugs

- a. Center new seal in opening.
- b. Place a suitable size socket (approximately 1-1/4") on the seal and using a soft hammer tap seal into place. (With front bearing retainer removed.)

22. Install rear bearings as follows: See Figure 72-224.

- a. Install large snap ring on rear bearing.
- b. Position bearing on output shaft with snap ring toward rear of shaft.

c. Thread Tool J-21774-2 all the way into J-21774-1 and place tools on mainshaft next to bearing.

d. Place mainshaft in vise with padded jaws.

e. Back Tool J-21774-2 out of J-21774-1 using Handle J-8614-1 until bearing is positioned correctly on mainshaft.

f. Remove mainshaft from vise and remove tools.

23. Remove speedometer driven

gear snap ring and tools.

24. Place speedometer drive gear locking ball in detent on output shaft and slide speedometer drive gear into place. Secure gear with snap ring.

25. Using a hook or your hand, lift countergear from bottom of case, and align it and thrust washers with the bore in case.

26. Working from rear of case, push alignment tool out of countergear with countershaft. Before countershaft is completely inserted, make certain that locking pin hole in shaft will line up with locking pin hole in case.

27. Drive shaft into place and insert locking pin.

28. Coat new extension housing gasket with sealer and install on case.

29. Dip threads of extension housing bolts in sealer.

30. Install extension housing. Torque bolts to 42-50 lb. ft.

31. Install filler and drain plugs in case, making sure magnetic plug is installed in bottom of case. Torque bolts to 20-30 lb. ft.

32. Place transmission in gear and put lubricant over entire gear train while rotating mainshaft.

33. Coat new cover gasket with sealer and install on case.

34. Install cover. Torque bolts to 14-19 lb. ft.

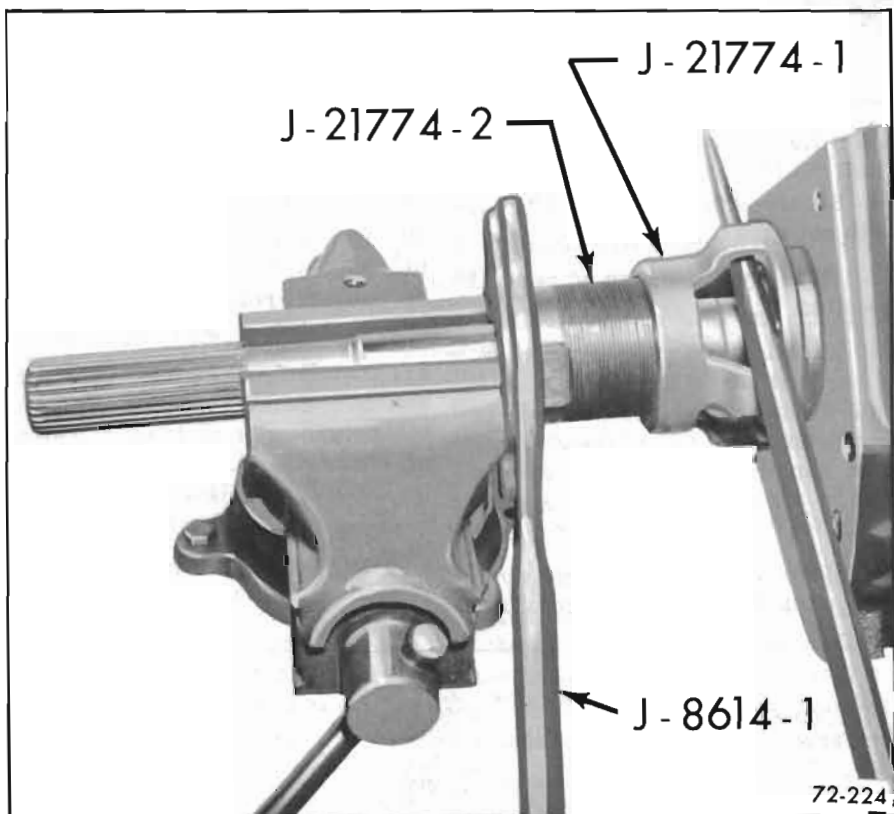

Figure 72-224—Installing Rear Bearing

DIVISION IV TROUBLE DIAGNOSIS

72-9 TROUBLE DIAGNOSIS

COMPLAINT	PROBABLE CAUSE
NOISY IN FORWARD SPEEDS	Low lubricant level. Incorrect lubricant. Transmission misaligned or loose. Main drive gear bearing worn or damaged. Mainshaft bearing worn or damaged. Countergear or bearings worn or damaged. Main drive gear worn or damaged. Synchronizers worn or damaged.
NOISY IN REVERSE	Reverse idler or shaft, worn or damaged. Reverse sliding gear worn or broken.
HARD SHIFTING	Clutch improperly adjusted. Shift linkage out of adjustment. Bent, damaged, or loose shift linkage. Shift levers, shafts, or forks worn. Incorrect lubricant. Synchronizers worn or broken.
JUMPING OUT OF GEAR	Shift linkage out of adjustment, worn or loose. Partial engagement of gear. Transmission misaligned or loose. Bent or worn shift fork, lever and/or shaft. Worn pilot bearing. End play in main drive gear (bearing retainer loose or broken, loose or worn bearings on main drive gear and mainshaft). Detent springs weak. Detent notches worn. Worn clutch teeth on main drive gear and/or worn clutch teeth on synchronizer sleeve. Worn or broken blocking rings. Bent mainshaft.
STICKING IN GEAR	Clutch not releasing fully. Low lubricant level. Incorrect lubrication. Corroded transmission levers (shaft). Defective (tight) main drive gear pilot bearing. Stuck detent plug. Frozen synchronizing blocking ring on main drive gear cone. Burred or battered teeth on synchronizer sleeve and/or main drive gear.

COMPLAINT	PROBABLE CAUSE
FORWARD GEARS CLASH	<p>Clutch not releasing fully. Weak or broken detent springs in the synchronizer assembly. Worn blocking rings and/or cone surfaces. Broken blocking rings. Excessive rock of synchronizer assembly on mainshaft. Excessive mainshaft end play.</p>
GEARS SPINNING WHEN SHIFTING INTO GEAR FROM NEUTRAL	<p>Clutch not fully releasing. Binding main drive gear pilot bearing. Synchronizers not functioning.</p>
REVERSE GEAR CLASH	<p>Allow approximately three - four seconds after the clutch pedal has been depressed before shifting into reverse gear. If gear clash continues after allowing proper time for the clutch plate to stop, check the clutch adjustments to make sure that they are within specifications. Make sure that the engine idle speed is set to specifications.</p> <p>Gear clash can also be caused by the following:</p> <ul style="list-style-type: none"> Dragging clutch plate. Distorted clutch plate. Tight or frozen main drive gear bearing.
SCORED OR BROKEN GEAR TEETH	<p>Insufficient lubricant. Failure of the car operator to fully engage the gears on every shift before engaging the clutch and applying engine power.</p>