

SECTION A

THREE-SPEED MANUAL TRANSMISSION

SPECIAL, SKYLARK AND LESABRE MODELS

CONTENTS

| Division | Paragraph | Subject | Page |
|----------|--|---|---|
| I | 72-1 | SPECIFICATIONS AND ADJUSTMENTS: General Specifications | 72-2 |
| II | 72-2 | DESCRIPTION AND OPERATION: Description of the 3-Speed | 72-3 |
| III | 72-3 72-4 72-5 72-6 72-7 72-8 72-9 72-10 72-11 | SERVICE PROCEDURES: Removal and Installation of Transmission Disassembly of Transmission Mainshaft Assembly Rear Bearing Retainer Seal and Bushing Countergear Assembly Side Cover Assembly Cleaning and Inspection of Transmission Parts Front Main Bearing Retainer Oil Seal Transmission Reassembly | 72-3 72-5 72-5 72-8 72-9 72-9 72-10 72-10 72-10 |
| IV | 72-12 | TROUBLE DIAGNOSIS: Trouble Diagnosis | 72-11 |

DIVISION I SPECIFICATIONS AND ADJUSTMENTS

72-1 GENERAL SPECIFICATIONS

a. Transmission Identification

A production code number is stamped on all Special, Skylark and LeSabre three-speed manual transmissions. The number is located just below the lower right hand side of the transmission side cover. See Figure 72-1.

This number should always be furnished on all product reports, AFA forms, and all correspondence with the factory concerning a particular transmission.

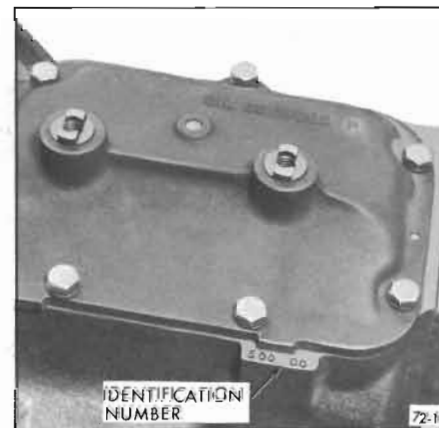

Figure 72-1—Transmission Code Number

b. General Specifications

| | | |
|----------------------------------|--------------------------------|-----------|
| Type | All Forward Gears Synchronized | |
| Mounting | Unit with Engine | |
| Lubricant | | |
| Type | SAE 80 or 80-90 Multi-Purpose | |
| Capacity | 3-1/2 Pints | |
| Synchronization | 1st, 2nd and 3rd | |
| Gear Ratios | V-6 | V-8 |
| 1st | 2.84 to 1 | 2.54 to 1 |
| 2nd | 1.68 to 1 | 1.50 to 1 |
| 3rd | 1.00 to 1 | 1.00 to 1 |
| Reverse | 2.94 to 1 | 2.63 to 1 |
| Gear Shifting | On Steering Column | |
| Speedometer Drive Gear | Press Fit | |

c. Bolt Tightening Specifications

| Location | Thread Size | Torque lb. ft. |
|---|-------------------|-------------------|
| Front Main Bearing Retainer | 5/16 - 18 x 3/4 | 8 - 12 lb. ft. |
| Side Cover to Case | 5/16 - 18 x 3/4 | 8 - 12 lb. ft. |
| Rear Main Bearing Retainer | 7/16 - 14 x 1-1/8 | 35 - 55 lb. ft. |
| Shift Lever to Shifter Shaft Bolts | 3/8 - 16 x 1 | 20 - 30 lb. ft. |
| Lubrication Filler Plug | 1/2 - 14 | 10 - 15 lb. ft. |
| Transmission Case to Flywheel Housing | 7/16 - 14 x 1-1/4 | 45 - 60 lb. ft. |

NOTE: These specifications are for clean and lubricated threads only. Dry or dirty threads produce increased friction which prevents accurate measurement of tightness.

Use a reliable torque wrench to tighten the attaching bolts of the above listed parts.

**DIVISION II
DESCRIPTION
AND OPERATION**

**72-2 DESCRIPTION OF THE 3-SPEED
MANUAL TRANSMISSION**

The Special, Skylark and LeSabre Series cars have as standard equipment a 3-speed manually operated transmission with all forward gears synchronized. All

forward speed changes are accomplished with synchronizer sleeves. See Figure 72-2. The synchronizers permit quicker shifts, greatly reduce gear clash, and permit down shifting from third to second between 40-20 MPH and from second to first BELOW 20 MPH. Power flow in all gears is shown in Figure 72-3.

**DIVISION III
SERVICE
PROCEDURES**

**72-3 REMOVAL AND INSTALLATION
OF TRANSMISSION**

a. Removal

1. Disconnect speedometer cable and remove driven gear and sleeve assembly.
2. Disconnect shift control rods from transmission.
3. Remove propeller shaft.
4. Support rear of engine and remove transmission support.

5. Remove the two-(2)-top transmission to flywheel housing bolts and insert guide pins.

6. Remove the two-(2)-lower transmission to flywheel housing attaching bolts.

7. Slide transmission straight back on guide pins until the main drive gear is free of splines in the clutch disc.

NOTE: If guide pins are not used damage to the clutch driven plate can result.

8. Remove transmission.

b. Installation

1. Install guide pin in upper and lower right transmission to flywheel housing bolt holes for alignment and place transmission on guide pins. Place transmission in third gear and rotate transmission mainshaft as necessary to start main drive gear into clutch disc. Slide transmission forward.

NOTE: If guide pins are not used damage to the clutch driven plate can result.

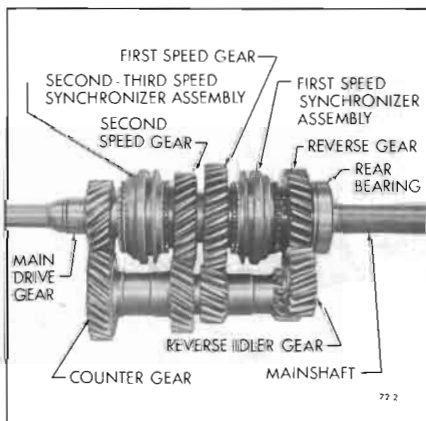
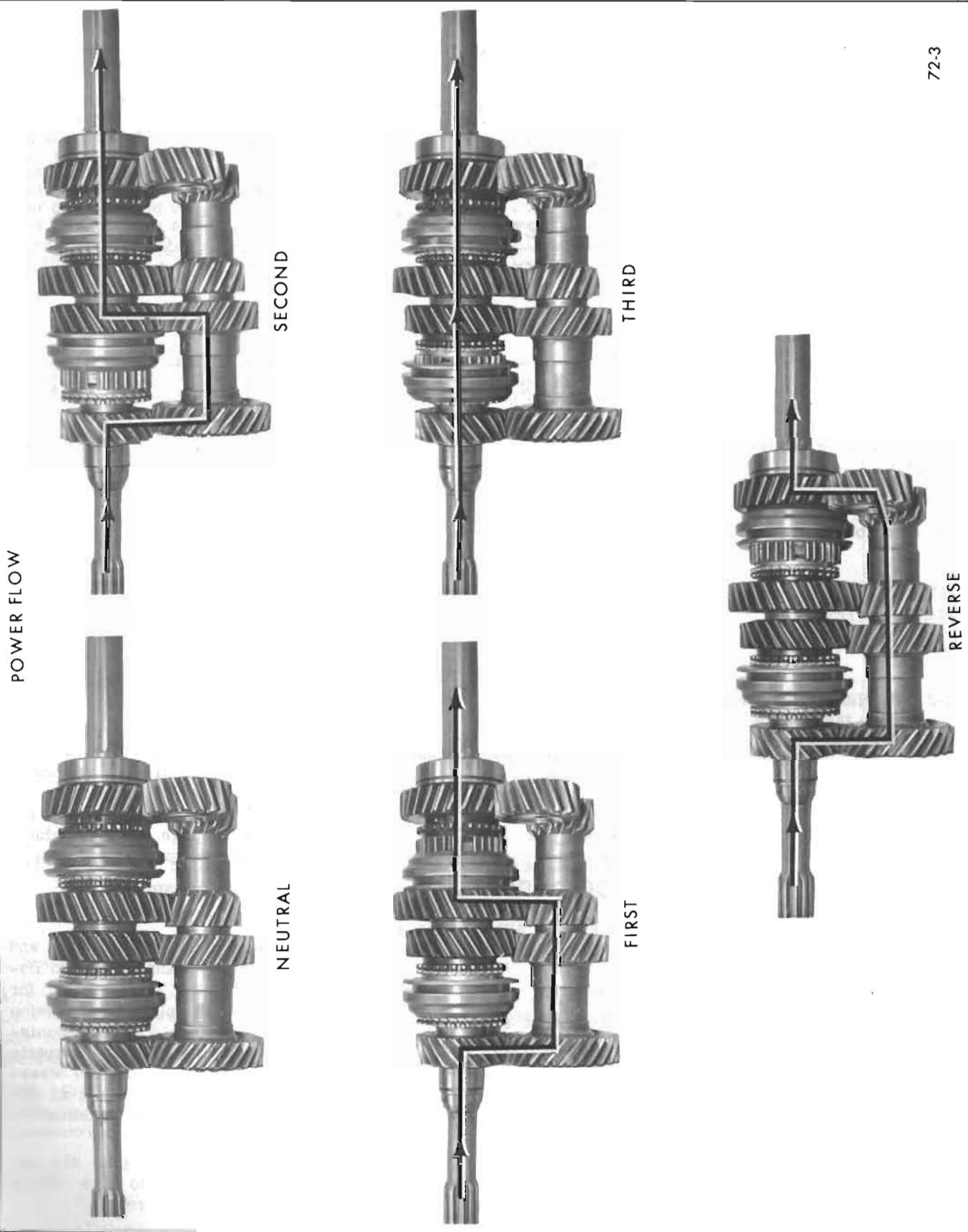

Figure 72-2—Gear Synchronizers



72-3

Figure 72-3—Power Flow

2. Install two (2) lower transmission mounting bolts. Remove guide pin and install two upper bolts. Torque bolts to 45-60 lb. ft.
3. Install transmission support.
4. Install propeller shaft.
5. Install speedometer driven gear and connect speedometer cable.
6. Connect linkage and adjust as described in Group 73.

72-4 DISASSEMBLY OF TRANSMISSION

1. Drain lubricant.
 2. Remove side cover attaching bolts. Remove side cover assembly and gasket.
 3. Remove front main bearing retainer and gasket.
 4. Remove front main bearing to main drive gear snap ring.
 5. Remove front main bearing by pulling main drive gear out of case as far as possible. See Figure 72-4. Remove front bearing.
- NOTE:** Front bearing is a slip fit on main drive gear. It may be necessary to aid removal with a screwdriver.
6. Remove rear bearing retainer to case attaching bolts.
 7. Remove reverse idler shaft to gear "E" ring. See Figure 72-5.

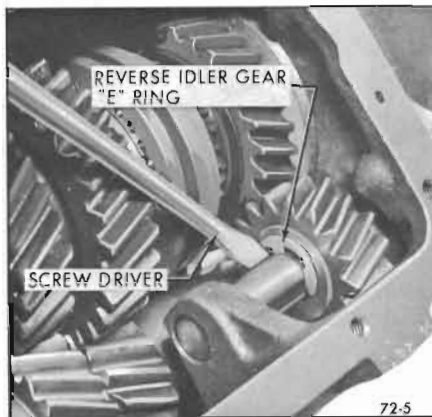

Figure 72-5—Removing Reverse Idler "E" Ring

8. From rear of case, remove rear bearing retainer and mainshaft assembly. See Figure 72-6.
9. Remove main drive gear, 14 needle bearings, and third speed blocking ring from mainshaft assembly.

10. Using snap ring pliers, expand snap ring at rear of bearing retainer which retains the rear bearing retainer to mainshaft. See Figure 72-7. Remove rear bearing retainer.

11. Using Countershaft Alignment Tool J-22246, remove countershaft gear shaft and its woodruff key through rear of case. See Figure 72-8. Remove two (2) tanged bronze thrust washers.

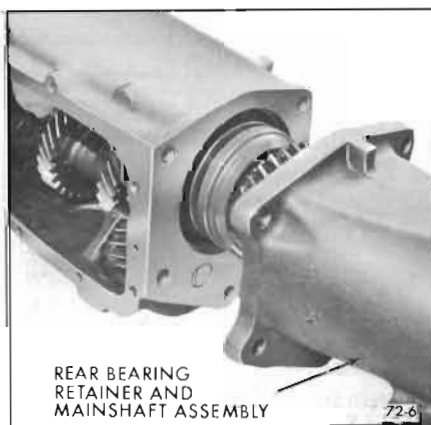

Figure 72-6—Removing Mainshaft Assembly

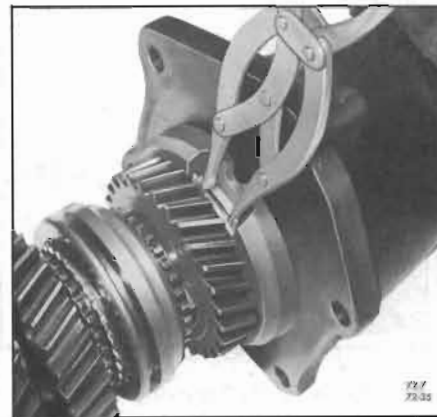

Figure 72-7—Removing Rear Bearing Retainer

12. Use a long brass drift or punch and drive reverse idler shaft and woodruff key through rear of case. See Figure 72-9.
13. Remove reverse idler gear tanged steel thrust washer.

72-5 MAINSHAFT ASSEMBLY

a. Disassembly

1. Remove second-third synchronizer sleeve. See Figure 72-10.
2. Remove rear bearing snap ring. See Figure 72-11.
3. Using ram press or arbor press, remove rear bearing, spring washer, thrust washer, and reverse gear. See Figure 72-12.



Figure 72-4—Removing Front Main Bearing



Figure 72-8—Removing Countershaft



Figure 72-9—Removing Reverse Idler Shaft

4. Remove speedometer drive gear. See Figure 72-13.

5. Remove first speed synchronizer snap ring. See Figure 72-14.

6. Support first speed gear on press plate using two (2) pieces of stock 6 x 1-7/8 x 1/4. See Figure 72-15. Remove first speed synchronizer assembly and first speed gear.

7. Remove second-third speed synchronizer assembly snap ring. See Figure 72-16.

8. Support second speed gear on press plate using two (2) pieces of stock 6 x 1-7/8 x 1/4. See Figure 72-17. Remove second-third speed synchronizer assembly and second speed gear.

b. Inspection

1. Check synchronizer hubs, slid-

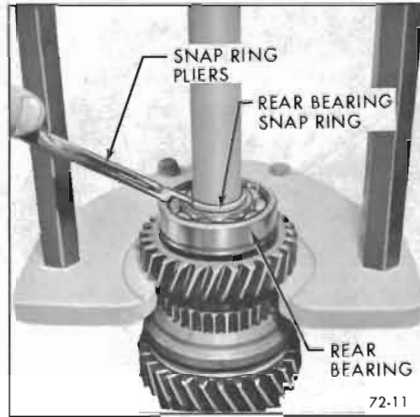

Figure 72-11—Removing Rear Bearing Snap Ring

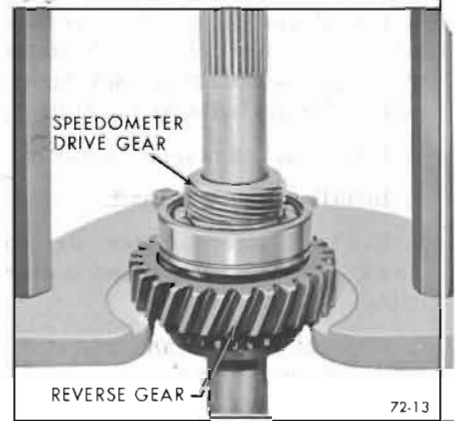

Figure 72-13—Removing Speedometer Drive Gear

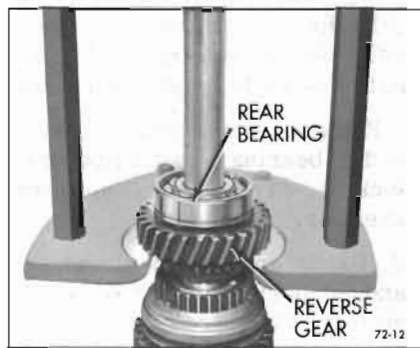

Figure 72-12—Removing Rear Bearing

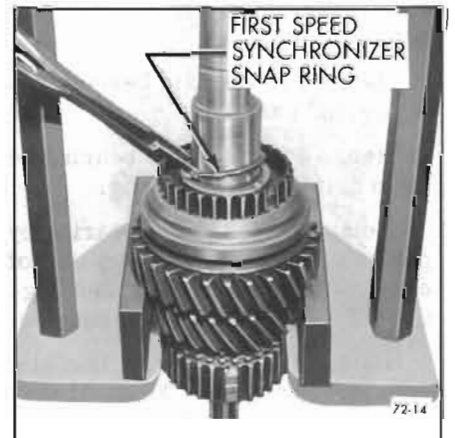

Figure 72-14—Removing First Speed Synchronizer Snap Ring

ing keys and springs and if necessary replace as follows:

NOTE: The synchronizer hubs and sliding sleeves are a selected assembly and should be kept together as originally assembled. The keys and springs

must be replaced if worn or broken.

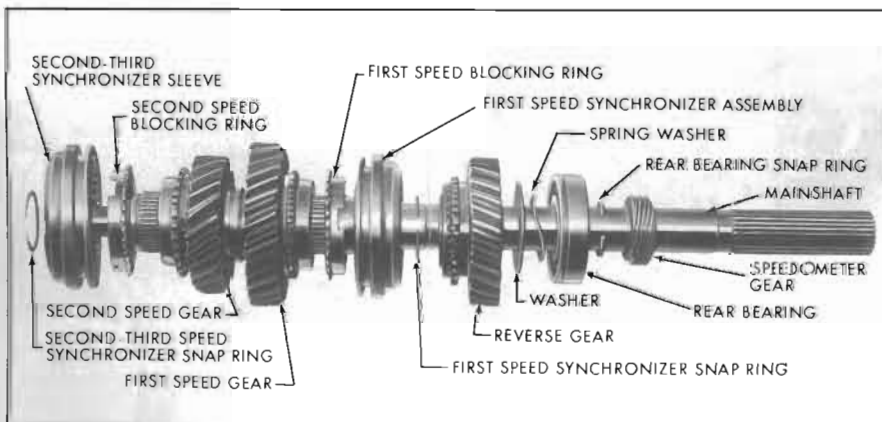

Figure 72-10—Exploded View of Mainshaft

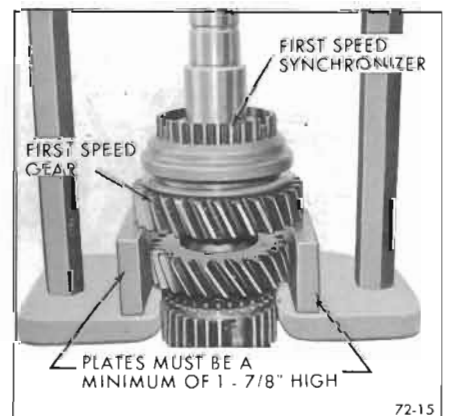

Figure 72-15—Removing First Speed Synchronizer Assembly

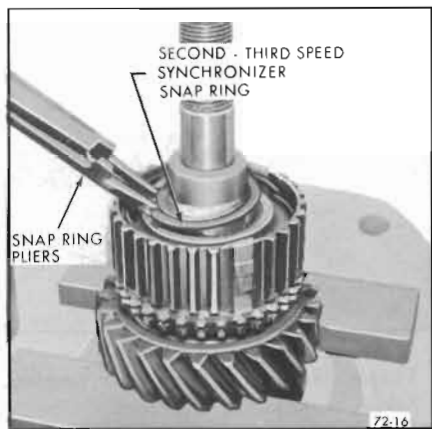

Figure 72-16—Removing Second-Third Speed Synchronizer Snap Ring

a. Mark hub and sleeve so they can be reassembled in the same position.

b. Remove sliding sleeve from synchronizer hub. Remove keys and springs from the hub.

c. Place the three (3) keys and two springs in position (one on each side of hub) so all three (3) keys are engaged by both springs. See Figure 72-18.

The tanged end of each synchronizer spring should be installed in different key cavities on either side of hub. Slide the sleeve onto the hub aligning the marks made before disassembly.

NOTE: A chamfer around the outside of the synchronizer hub

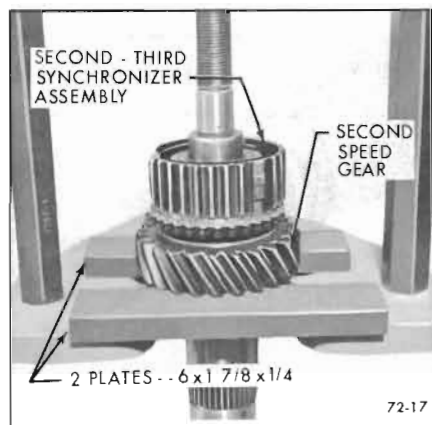

Figure 72-17—Removing Second-Third Speed Synchronizer Assembly

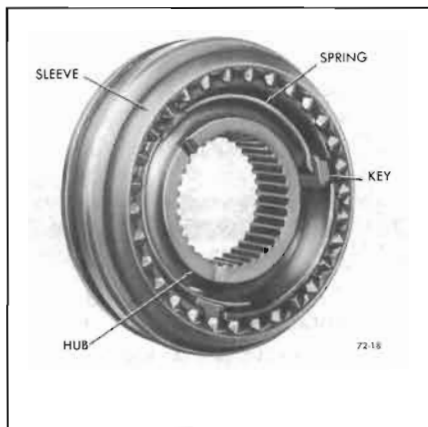

Figure 72-18—Synchronizer Assembly splines identifies the end that must be opposite the fork slot in the sleeve. See Figure 72-19.

2. Wash the front and rear bearing thoroughly in a cleaning solvent. Blow out bearing with compressed air.

CAUTION: Do not allow the bearings to spin; turn them slowly by hand. Spinning bearings will damage the race and balls.

Make certain bearings are clean, then lubricate with light engine oil and check them for roughness by slowly turning the race by hand.

3. Check for cracks in blocking rings.

c. Assembly

1. Install second speed gear and

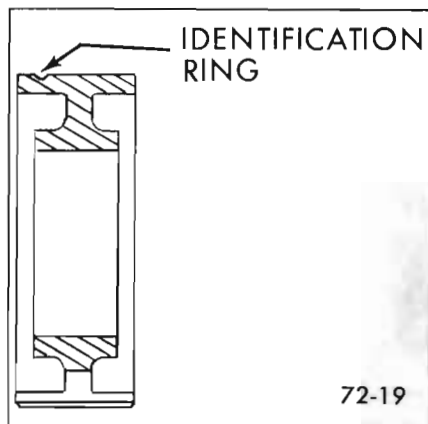

Figure 72-19—Identification Chamfer

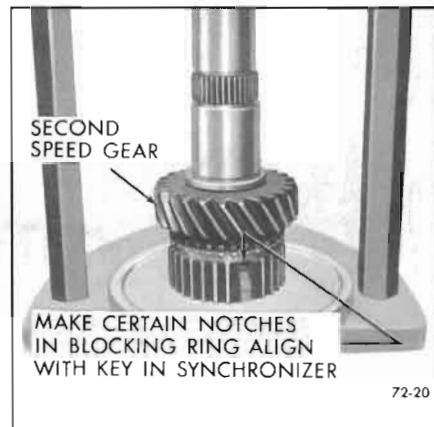

Figure 72-20—Installing Second Speed Gear

synchronizer on mainshaft. Using ram press or arbor press and Press Plate J-8609, press second-third speed synchronizer assembly (with chamfer toward rear of transmission) onto mainshaft. See Figure 72-20. Install retaining snap ring.

CAUTION: MAKE CERTAIN NOTCHES IN BLOCKING RING ALIGN WITH KEYS IN SYNCHRONIZER ASSEMBLY.

2. Install first speed gear and synchronizer on mainshaft. See Figure 72-21. Using ram press and Press Plate J-8609, press first speed synchronizer assembly onto mainshaft. Install retaining snap ring.

CAUTION: MAKE CERTAIN NOTCHES IN BLOCKING RING

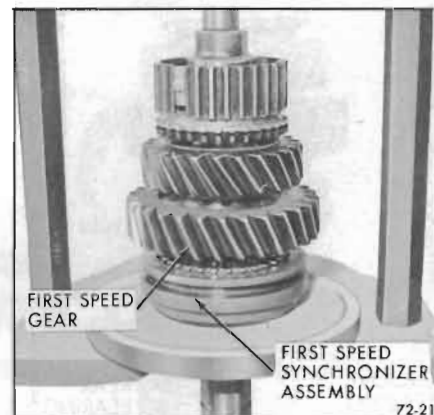

Figure 72-21—Installing First Speed Gear

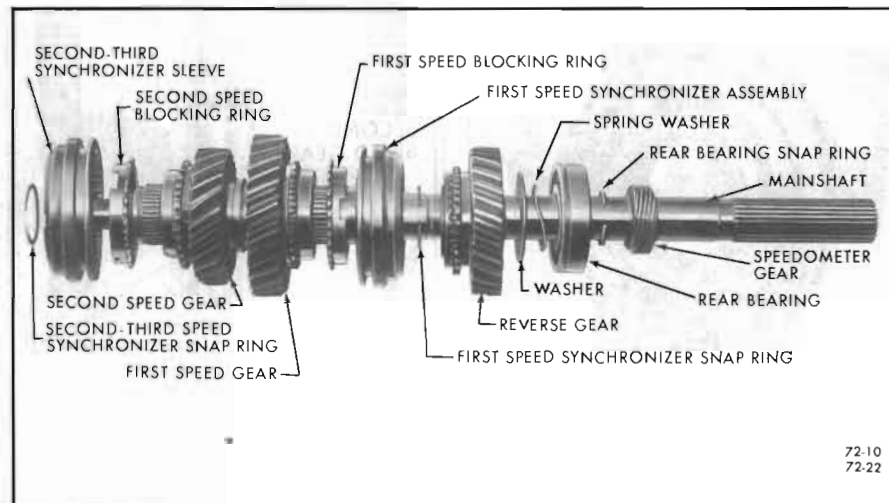

Figure 72-22—Exploded View of Mainshaft

ALIGN WITH KEYS IN FIRST SPEED SYNCHRONIZER ASSEMBLY.

3. Install reverse gear, thrust washer, spring washer, and rear bearing. See Figure 72-22.

NOTE: Groove on bearing must be toward reverse gear. Using ram press or arbor press, press rear bearing into position. See Figure 72-23. Install retaining snap ring.

4. Install speedometer drive gear onto mainshaft. Using Press Plate J-8609, press gear until rear face of gear is 6" from rear bearing. See Figure 72-24.



Figure 72-23—Installing Rear Bearing

5. Install second-third synchronizer sleeve. See Figure 72-22.

72-6 REAR BEARING RETAINER SEAL AND BUSHING

a. Removal

1. Using J-2619, Slide Hammer and J-4830-02 Puller, remove rear bearing retainer oil seal. See Figure 72-25.

2. Using J-2619 Slide Hammer and J-4830-02, remove rear bearing retainer bushing. See Figure 72-26.

b. Installation

1. Install rear bearing retainer

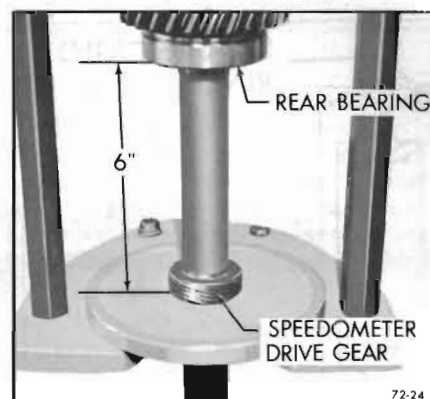

Figure 72-24—Installing Speedometer Drive Gear

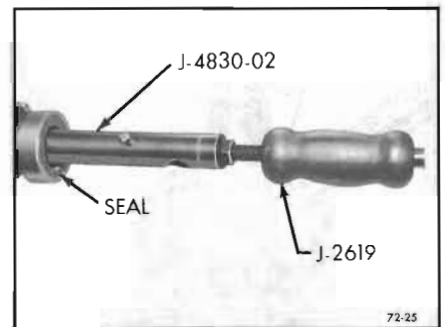

Figure 72-25—Removing Rear Bearing Retainer Oil Seal

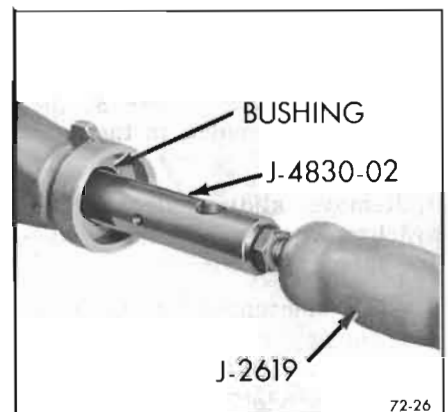

Figure 72-26—Removing Rear Bearing Retainer Bushing

bushing, using Tool J-6403-1. See Figure 72-27.

2. Install rear bearing retainer oil seal as follows:

a. Install J-6403-2 onto J-6403-1. See Figure 72-28.

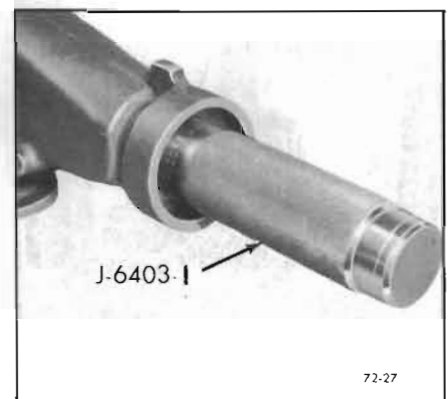

Figure 72-27—Installing Rear Bearing Retainer Bushing

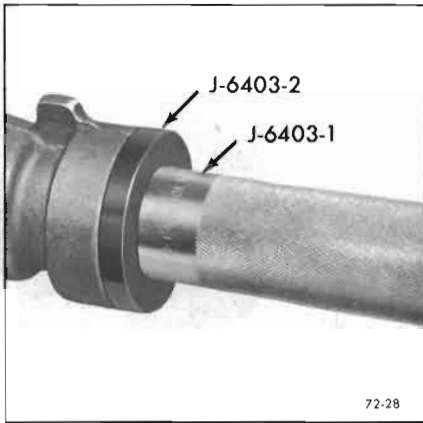

Figure 72-28—Installing Rear Bearing Retainer Oil Seal

NOTE: Flat side of J-6403-2 must be toward rear of J-6403-1.

b. Install oil seal.

72-7 COUNTERGEAR ASSEMBLY

a. Disassembly

1. Remove Countershaft Alignment Tool J-22246.
2. From each end of countershaft, remove spacer and 27 needle bearings. See Figure 72-29.

b. Inspection

1. Check for broken needle bearings.
2. Check for broken anti-rattle springs. See Figure 72-30.

NOTE: The anti-rattle gear is riveted to the countergear in four (4) places and is not serviced separately.

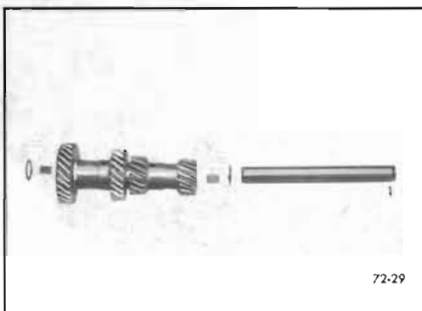

Figure 72-29—Exploded View of Countergear



Figure 72-30—Anti-rattle Gear

c. Assembly

1. Install Countershaft Alignment Tool J-22246.
2. From each end of countergear, install 27 needle bearings and spacer. See Figure 72-29.

NOTE: Coat needle bearings with heavy grease before installing.

72-8 SIDE COVER ASSEMBLY

a. Disassembly (See Figure 72-31)

1. Remove detent cam spring.
2. Remove shifter forks.
3. Remove shifter shafts.
4. Remove detent cam retainer.
5. Remove detent cams.
6. Inspect shifter shaft "O" rings and replace if necessary.

b. Assembly (See Figure 72-31)

1. Install shifter shaft "O" rings if removed.
2. Install detent cams.

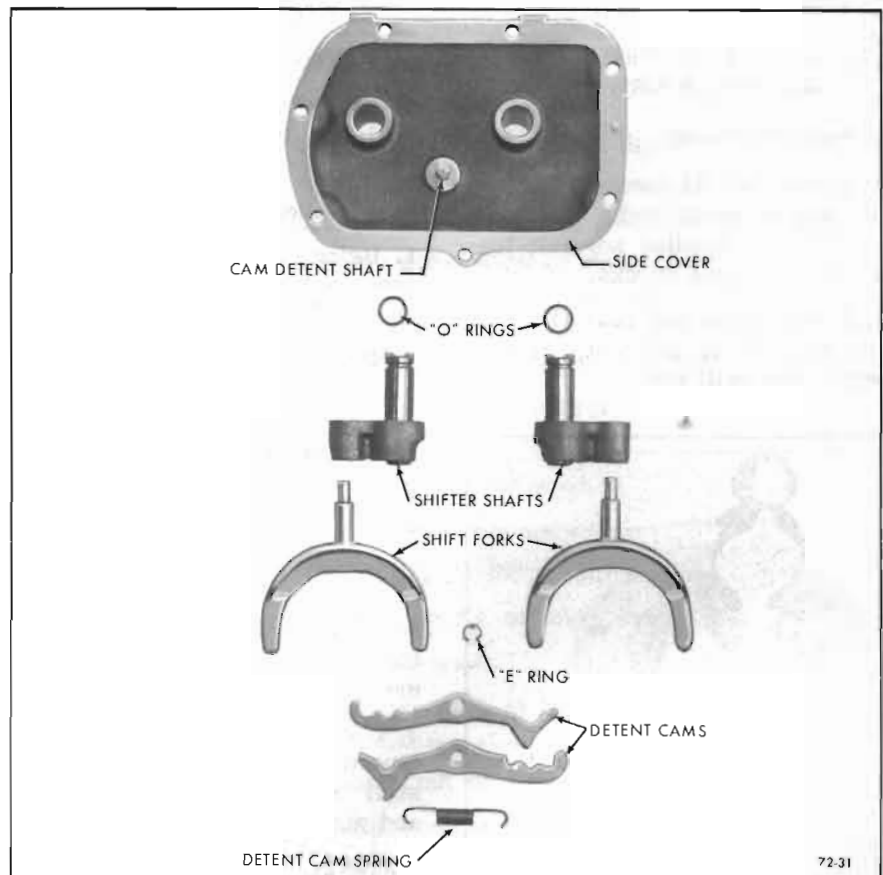

Figure 72-31—Exploded View of Side Cover

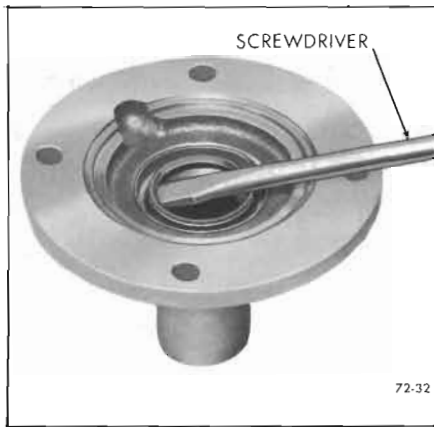

Figure 72-32—Removing Front Bearing Retainer Seal

3. Install detent cam retainer.
4. Install shifter shafts.
5. Install shifter forks.
6. Install detent cam spring.

NOTE: Detent cams, shifter shafts and forks are interchangeable.

72-9 CLEANING AND INSPECTION OF TRANSMISSION PARTS

a. Transmission Case

1. Wash the transmission case thoroughly inside and outside with a suitable cleaning solvent; then inspect case for cracks.
2. Check front and rear faces for burrs, and if present, remove with a fine mill file.

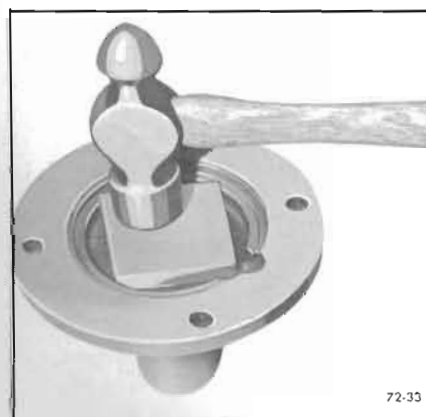

Figure 72-33—Installing Front Bearing Retainer Seal

3. Check and clean magnet in bottom of transmission case.

b. Needle Bearings

All main drive gear and counter-gear needle bearings should be inspected closely and replaced if they show wear.

c. Transmission Gears

1. Inspect all gears for excessive wear, chips or cracks.
2. Inspect reverse gear bushing and if worn or damaged, replace the entire gear.

NOTE: Reverse gear bushing is not serviced separately.

3. Inspect reverse idler gear bushing and if worn or damaged, replace the entire gear.

72-10 FRONT MAIN BEARING RETAINER OIL SEAL

a. Removal

1. Using screwdriver remove seal. See Figure 72-32.

b. Installation

1. Using a suitable tool, drive new seal into position. See Figure 72-33.

NOTE: Lip of seal must face rear of bearing retainer.

72-11 TRANSMISSION REASSEMBLY

1. Install countergear to case bronze thrust washers.
2. Install countergear into case. Install countergear shaft from rear of case. Make certain woodruff key is in position. See Figure 72-34.
3. Install reverse idler gear tanged steel thrust washer. Install reverse idler gear, shaft and woodruff key.

NOTE: Reverse idler gear snap ring will be installed after installation of mainshaft.

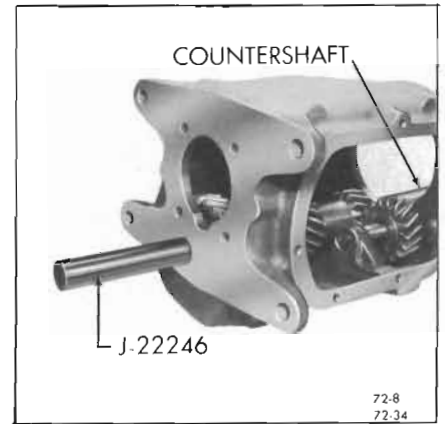

Figure 72-34—Installing Countergear

4. Install the rear bearing retainer. Spread snap ring in the retainer to allow the snap ring to drop around rear bearing. See Figure 72-35. Press on end of mainshaft until the snap ring engages groove in rear bearing.

5. Install fourteen (14) needle bearings in the main drive gear, using heavy grease to hold the bearings in place. See Figure 72-36.

6. Assemble third speed blocking ring on main drive gear.

7. Pilot main drive gear and third speed blocking ring over front of mainshaft.

CAUTION: MAKE CERTAIN NOTCHES IN BLOCKING RING

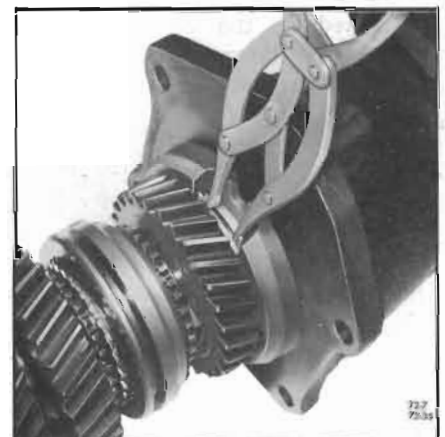

Figure 72-35—Installing Rear Bearing Retainer

ALIGN WITH KEYS IN SECOND-THIRD SYNCHRONIZER ASSEMBLY.

8. Using heavy grease, install rear bearing retainer to case gasket.

9. Install rear bearing retainer and mainshaft assembly into case. Install bearing retainer to case bolts. Torque 35-55 ft. lbs.

10. Install front main bearing onto main drive gear. Outer snap ring groove must be toward front of gear.

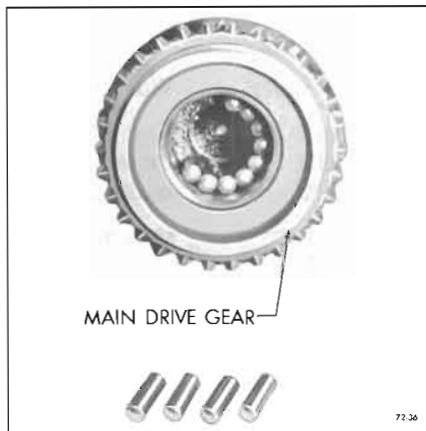

Figure 72-36—Installing Needle Bearings

11. Install retaining snap ring.

12. Install front main bearing retainer, gasket and four (4) attaching bolts, torque 8-12 lb. ft.

NOTE: The retainer oil return hole must be at the bottom of case.

13. Install reverse idle gear "E" ring.

14. Install new side cover gasket. Place transmission in neutral and install side cover. Install attaching bolts and tighten evenly to avoid side cover distortion. Torque 8-12 lb. ft.

DIVISION IV TROUBLE DIAGNOSIS

72-12 TROUBLE DIAGNOSIS

| COMPLAINT | PROBABLE CAUSE |
|-------------------------|---|
| NOISY IN FORWARD SPEEDS | <p>Low lubricant level.</p> <p>Incorrect lubricant.</p> <p>Transmission misaligned or loose.</p> <p>Main drive gear bearing worn or damaged.</p> <p>Counter gear or bearings worn or damaged.</p> <p>Main drive gear worn or damaged.</p> <p>Synchronizers worn or damaged.</p> |
| NOISY IN REVERSE | <p>Reverse idler gear or shaft, worn or damaged.</p> <p>Reverse gear worn or broken.</p> |
| HARD SHIFTING | <p>Clutch improperly adjusted.</p> <p>Shift linkage out of adjustment.</p> <p>Bent, damaged, or loose shift linkage.</p> <p>Shift levers, shafts, or forks worn.</p> <p>Incorrect lubricant.</p> <p>Synchronizers worn or broken.</p> |
| JUMPING OUT OF GEAR | <p>Shift linkage out of adjustment, worn or loose.</p> <p>Partial engagement of gear.</p> <p>Transmission misaligned or loose.</p> <p>Bent or worn shift fork, lever and/or shaft.</p> |

| COMPLAINT | PROBABLE CAUSE |
|---|--|
| JUMPING OUT OF GEAR (CONT'D.) | <p>Worn pilot bearing.</p> <p>End play in main drive gear (bearing retainer loose or broken, loose or worn bearings on main drive gear and output shafts).</p> <p>Detent cam spring weak.</p> <p>Detent cam notches worn.</p> <p>Worn clutch teeth on main drive gear and/or worn clutch teeth on synchronizer sleeve.</p> <p>Worn or broken synchronizer.</p> <p>Bent output shaft.</p> |
| STICKING IN GEAR | <p>Clutch not releasing fully.</p> <p>Low lubricant level.</p> <p>Incorrect lubrication.</p> <p>Corroded transmission levers (shaft).</p> <p>Defective (tight) main drive gear pilot bearing.</p> <p>Frozen synchronizing blocking ring on main drive gear cone.</p> <p>Burred or battered teeth on synchronizer sleeve and/or main drive gear.</p> |
| FORWARD GEARS CLASH | <p>Clutch not releasing fully.</p> <p>Weak or broken springs in the synchronizer assembly.</p> <p>Worn blocking rings and/or cone surfaces.</p> <p>Broken blocking rings.</p> <p>Excessive rock of synchronizer assembly on mainshaft.</p> |
| GEARS SPINNING WHEN SHIFTING INTO GEAR FROM NEUTRAL | <p>Clutch not fully releasing.</p> <p>Binding main drive gear pilot bearing.</p> <p>Synchronizers not functioning.</p> |
| REVERSE GEAR CLASH | <p>Allow approximately three - four seconds after the clutch pedal has been depressed before shifting into reverse gear.</p> <p>If gear clash continues after allowing proper time for the clutch plate to stop, check the clutch adjustments to make sure that they are within specifications.</p> <p>Make sure that the engine idle speed is set to specifications.</p> |

| COMPLAINT | PROBABLE CAUSE |
|------------------------------|---|
| REVERSE GEAR CLASH (CONT'D.) | Gear clash can also be caused by the following: Dragging clutch plate. Distorted clutch plate. Tight or frozen main drive gear bearing. |
| SCORED OR BROKEN GEAR TEETH | Insufficient lubricant. Failure of the car operator to fully engage the gears on every shift before engaging the clutch and applying engine power. |

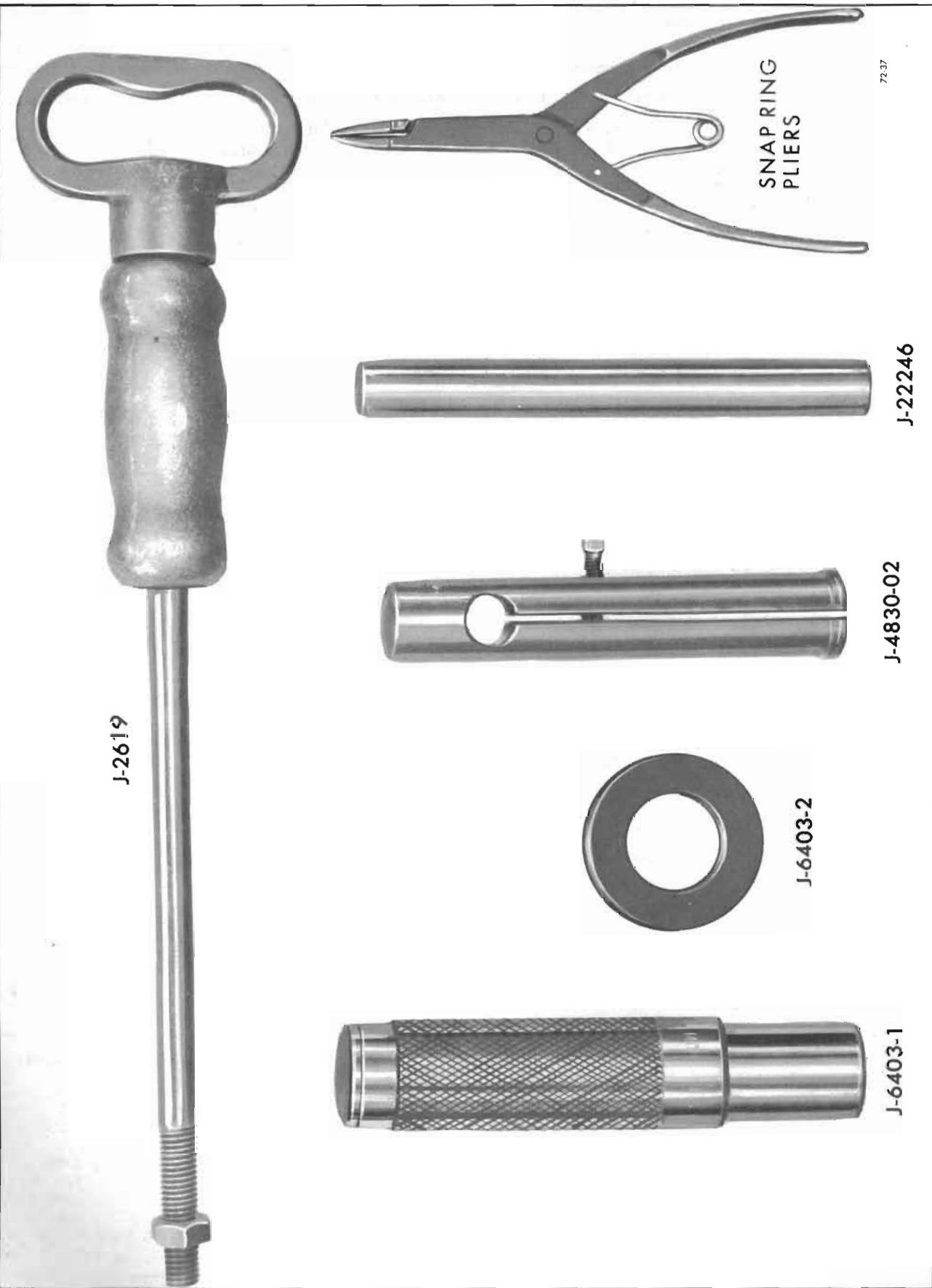

Figure 72-37—Tool Picture