

# SECTION G

## CRUISE CONTROL

### CONTENTS

Division	Paragraph	Subject	Page
I		SPECIFICATIONS AND ADJUSTMENTS	
II	64-36	DESCRIPTION AND OPERATION: Description and Operation of Electro-Cruise . . . . .	64-66
III	64-37	SERVICE PROCEDURES: Electro-Cruise Service Procedures . . . . .	64-72
IV	64-38	TROUBLE DIAGNOSIS: Electro-Cruise Trouble Diagnosis . . . . .	64-73

## DIVISION II

### DESCRIPTION AND OPERATION

#### 64-36 DESCRIPTION AND OPERATION OF ELECTRO-CRUISE

##### a. Description

The Electro-Cruise is a driver-operated speed regulating system capable of accurate control of car speed over a wide range of operating conditions. A speed range of 30 to 90 MPH can be accurately held within 3 MPH of the particular speed setting. Unlike a constant throttle device, which locks the throttle in a fixed position resulting in speed variation according to varying road conditions, the Electro-Cruise system compares a measurement of actual car speed with the selected speed to maintain the selected speed under varying road conditions.

The Electro-Cruise is offered as optional equipment on LeSabres, Wildcats, Electras and Rivieras. Basic operation of the system is

the same in all series. However, there is a difference in the appearance of the speedometer used in the Riviera. See Figures 64-87 and 64-88.

The Electro-Cruise is an electronic-vacuum system which consists of a power unit connected to the throttle linkage through a bead chain, an

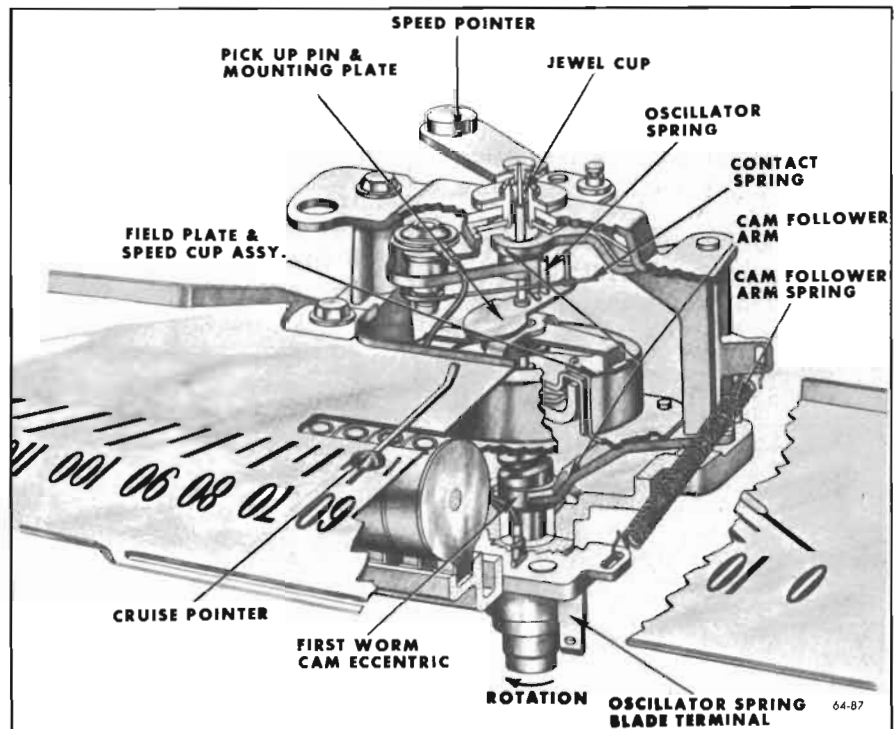

Figure 64-87—Electro-Cruise Speedometer - LeSabre, Wildcat and Electra

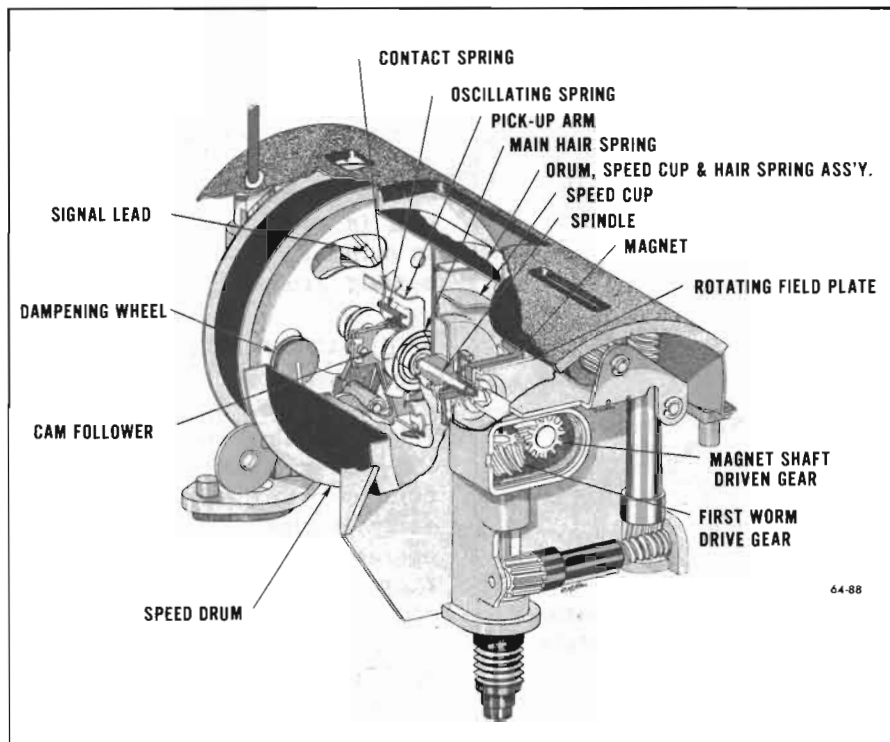

Figure 64-88—Electro-Cruise Speedometer - Riviera

amplifier and a relay, electrical contacts which are an integral part of the speedometer, an engagement switch, a CRUISE lamp, and a cruise release brake switch located on the brake pedal support bracket.

Driver operating instructions follow:

**1. SPEED SETTING.** Rotate speed knob (on speedometer) until desired cruise speed is indicated. (Cruise speed may also be reset with cruise system in operation.)

**2. ENGAGEMENT.** Push engage knob forward and hold in until set speed is reached. At this time, CRUISE light will come on and cruise system will control speed of car until cruise is disengaged.

**ALTERNATE ENGAGEMENT.** Bring car up to set speed with accelerator pedal, and then engage cruise control by depressing engagement knob.

**3. DISENGAGEMENT.** Disengage cruise system by depressing

brake pedal slightly, by pulling the engagement knob rearward, or by turning the ignition switch off. Once the cruise system has been disengaged, it is necessary to re-engage the system using one of the procedures above.

**4. OVER-RIDE.** Depress accelerator pedal as desired at any time to over-ride cruise control speed setting. When accelerator is released, cruise control will again maintain the set speed without re-engagement.

**5. SAFETY PRECAUTIONS.** Never use Electro-Cruise under traffic, road or weather conditions not suited to maintaining a constant speed.

#### b. Electro-Cruise Units

**1. SPEEDOMETER.** A special speedometer is required containing speed control contacts and also a means for setting the desired cruise speed.

**2. POWER UNIT.** The power unit is basically a vacuum cham-

ber containing: a power diaphragm; a diaphragm return spring; an air orifice; a vacuum orifice; a control valve; a control valve return spring; a control valve coil; an air filter; and a brake release line fitting. See Figure 64-89. When the control valve coil is energized, the "teeter-totter" armature of the control valve is pulled down against spring tension, closing the air port to atmosphere, and opening the vacuum port to the diaphragm chamber. The vacuum admitted increases tension on the bead chain to open the throttle.

When the control valve is not energized, spring tension positions the "teeter-totter" armature of the control valve to close the vacuum port and open the air port to the vacuum chamber. The air admitted reduces tension on the bead chain to close the throttle.

Through continual cycling of the control valve, a vacuum level is selected in the power unit which will produce the required throttle opening to maintain the set speed. Maximum throttle opening as caused by full power unit travel is approximately 35°; therefore, when the control valve coil is continually energized (such as while accelerating up to the set speed), the car will be accelerated at this throttle angle.

**3. AMPLIFIER.** The amplifier is a four tang plug-in unit consisting of an aluminum housing, a transistor, a diode and two resistors. The amplifier and the relay each plug-in separately in the same junction block.

In order to understand the operation of the amplifier, one must understand the basic theory of operation of a transistor. A transistor is an electrical switching device used to control a large current by means of a small current. Figure 64-90 shows a

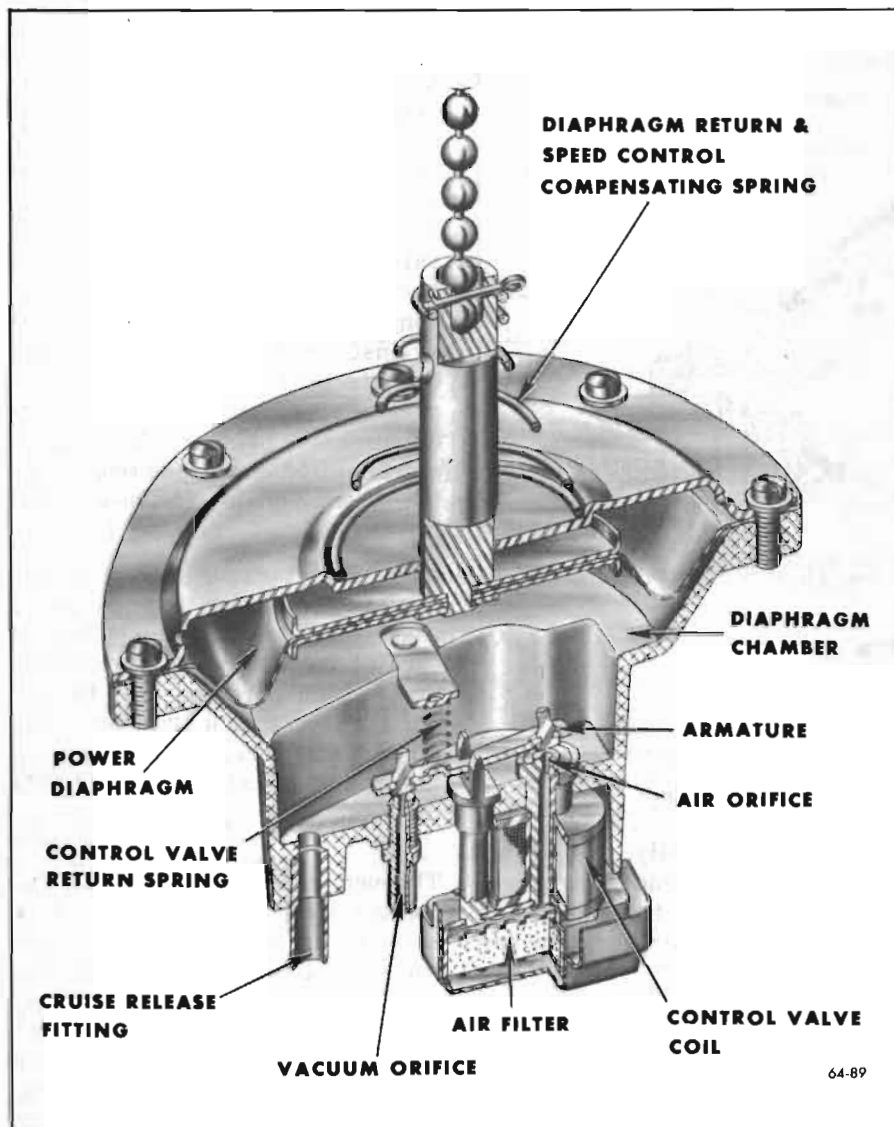

Figure 64-89—Power Unit

transistor schematically. When the transistor is "switched-on", the large current flow is shown by the large arrow; the small current flow bleeds off from the large flow through the base circuit and is shown by the small arrow. See Figure 64-90. Any time this small current is flowing, the transistor is electronically "switched-on" so that the large current flows through freely; however, if the small current is shut-off externally, the large current is also shut-off electronically in the transistor - instantly and completely.

In the Electro-Cruise system, the transistor large current goes directly to ground; the small current goes into the speedometer and goes to ground through the speed control contacts. Since the small current is only about .02 ampere, the speedometer contacts can be light, so as not to interfere with normal speed pointer movement, but still have long contact life.

4. **RELAY.** The relay has a base similar to a radio tube; it plugs into the same junction block as the amplifier. The relay contains

two opposite wound coils on one core, and an armature that operates between two sets of contacts. When both relay coils are energized, they neutralize each other and no armature movement results; however, when only one coil is energized, the armature is pulled down to the core, overcoming armature spring tension.

5. **ENGAGEMENT SWITCH.** The engagement switch is a three position switch, spring-loaded to return to its center position. In the center position, a circuit is completed to the relay; when the relay is closed, this circuit will operate the cruise control. In the forward (pushed-in) position, a circuit is completed which causes the car to accelerate up to the set speed; at this point, the relay closes and it is no longer necessary to hold the switch in. In the rearward (pulled-out) switch position, the cruise control feed circuit is completely cut-off.

6. **CRUISE RELEASE BRAKE SWITCH.** When the brake pedal is depressed 1/4 inch, the brake release switch is actuated to stop cruise control operation in two ways: (1) A switch opens to interrupt the electrical feed circuit. (2) A flap type valve opens to vent the power unit diaphragm chamber to atmosphere, thereby eliminating all vacuum from the power unit.

#### c. Operation of Electro-Cruise

This is a simplified step-by-step explanation of the electrical flow in the Electro-Cruise system. Follow this explanation on the schematic diagram, Figures 64-91 or 64-92.

Starting with the source of electricity, the battery (or generator), the flow is through the ignition switch, the CRUISE fuse on the fuse block, the cruise release brake switch at the brake pedal and into the engagement switch.

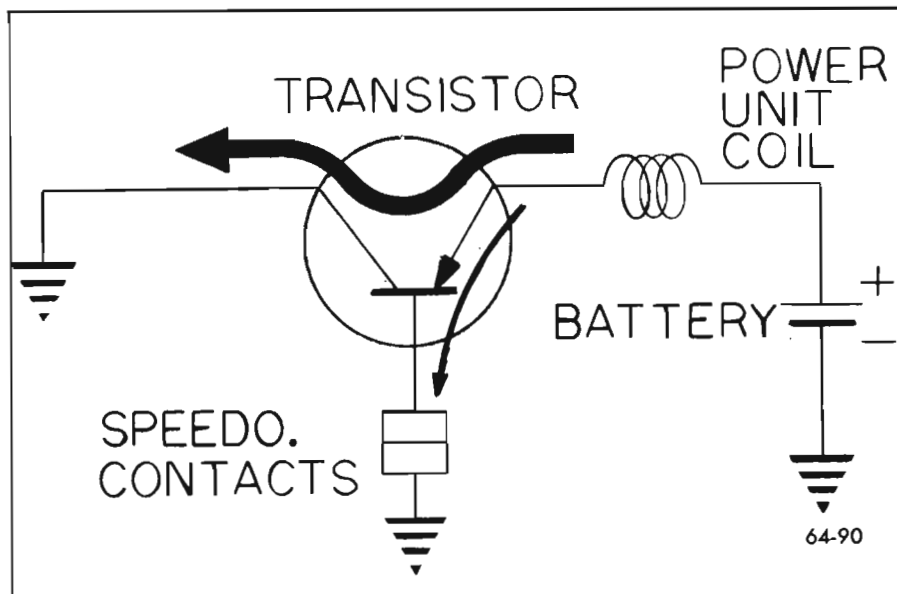

Figure 64-90—Transistor Operation

This switch is spring loaded to return to its center position, where it is connected by a white wire to the switch shorting relay. This relay normally interrupts the circuit because its armature is held upward by a spring. See Figure 64-91.

When the engagement switch knob is pushed in (forward), however, a connection is made to the red with white stripe wire, through the power unit coil, through the tan wire, through the transistor in the amplifier, through the black wire to ground. Whenever this circuit is complete, the power unit is calling for more car speed. Whenever this circuit is not complete (due to releasing the engagement switch before the set speed is reached, or due to a switching-off process at the transistor), the power unit is calling for less car speed. This is the basic operating circuit of the cruise control.

The purpose of the transistor is to provide a durable means for switching the power unit on and off. A transistor is an electrical switching device used to control a large current by means of a

small current. A small current (only about .02 ampere) flows from the base of the transistor, through contacts in the speedometer to ground. Whenever current is flowing in this small base current circuit, the transistor is switched on so that the current from the power unit coil goes directly to ground. However, when the speedometer contacts open (such as when the car comes up to the set speed), shutting off the small base current completely switches off the large current at the transistor. See Figure 64-90.

During car acceleration, current is also flowing through two opposite wound relay coils: (1) from the red with white stripe wire through the holding coil of the relay to ground; (2) through the upper relay contacts, through the inhibiting coil of the relay, through the transistor to ground. Since these two coils are wound opposite, they neutralize each other and have no effect on the relay armature.

Now let's see what happens when the car first reaches the speed set on the dial. The instant this happens, the contacts in the

speedometer are physically separated and the transistor is switched off. Since the inhibiting coil current flows to ground through the transistor, it is also shut off and the holding coil (now unopposed) pulls the relay armature down, closing two sets of contacts. The switch shorting contacts of the relay now connect the white (normally hot) wire to the red with white stripe wire, making it no longer necessary to hold the engagement switch forward; the telltale light contacts complete a circuit through the CRUISE telltale lamp. The lighted CRUISE lamp gives notice that the cruise control is 'locked-in' and is now controlling the car speed.

The Electro-Cruise accurately maintains the set speed by timing the open versus the closed time of the speed control contacts in the speedometer. When the car is cruising exactly at the set speed, the contacts are closed equally as long as they are open. When the car speed is more than 3 MPH below the set speed, the contacts are closed continually. When the car speed is more than 3MPH above the set speed, the contacts are open continually. When car speed is anywhere within 3 MPH of the set speed, open versus closed time of the contacts is determined by a cam in the speedometer which revolves once per revolution of the speedometer cable.

During the time the speedometer contacts are closed, a control (teeter-totter) valve in the power unit closes the air port and opens the vacuum port; during the time the contacts are open, the valve in the power unit opens the air port and closes the vacuum port. See Figure 64-89. Through continual cycling of the control valve, a vacuum level is selected in the power unit which will produce the required throttle opening to maintain the set speed.

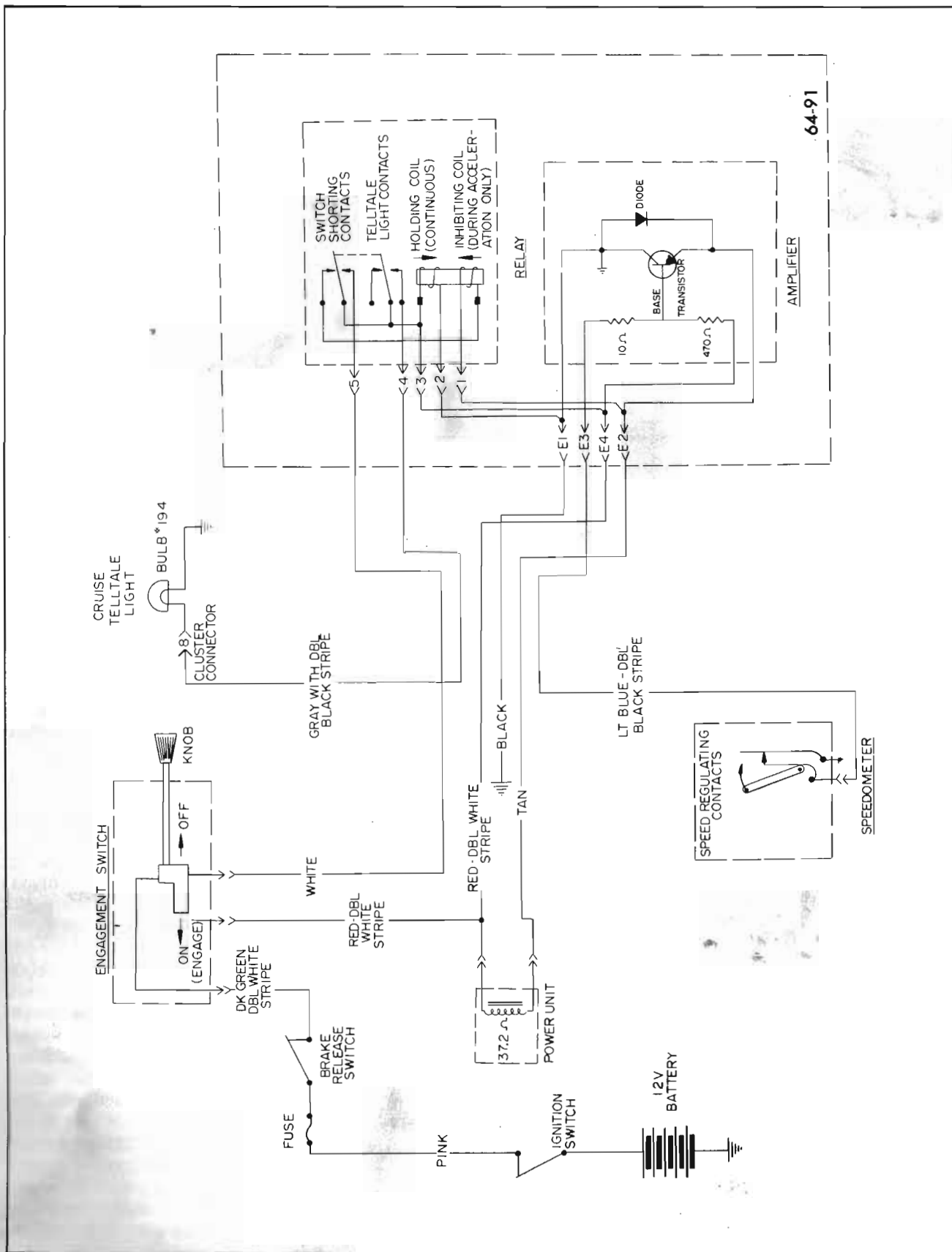
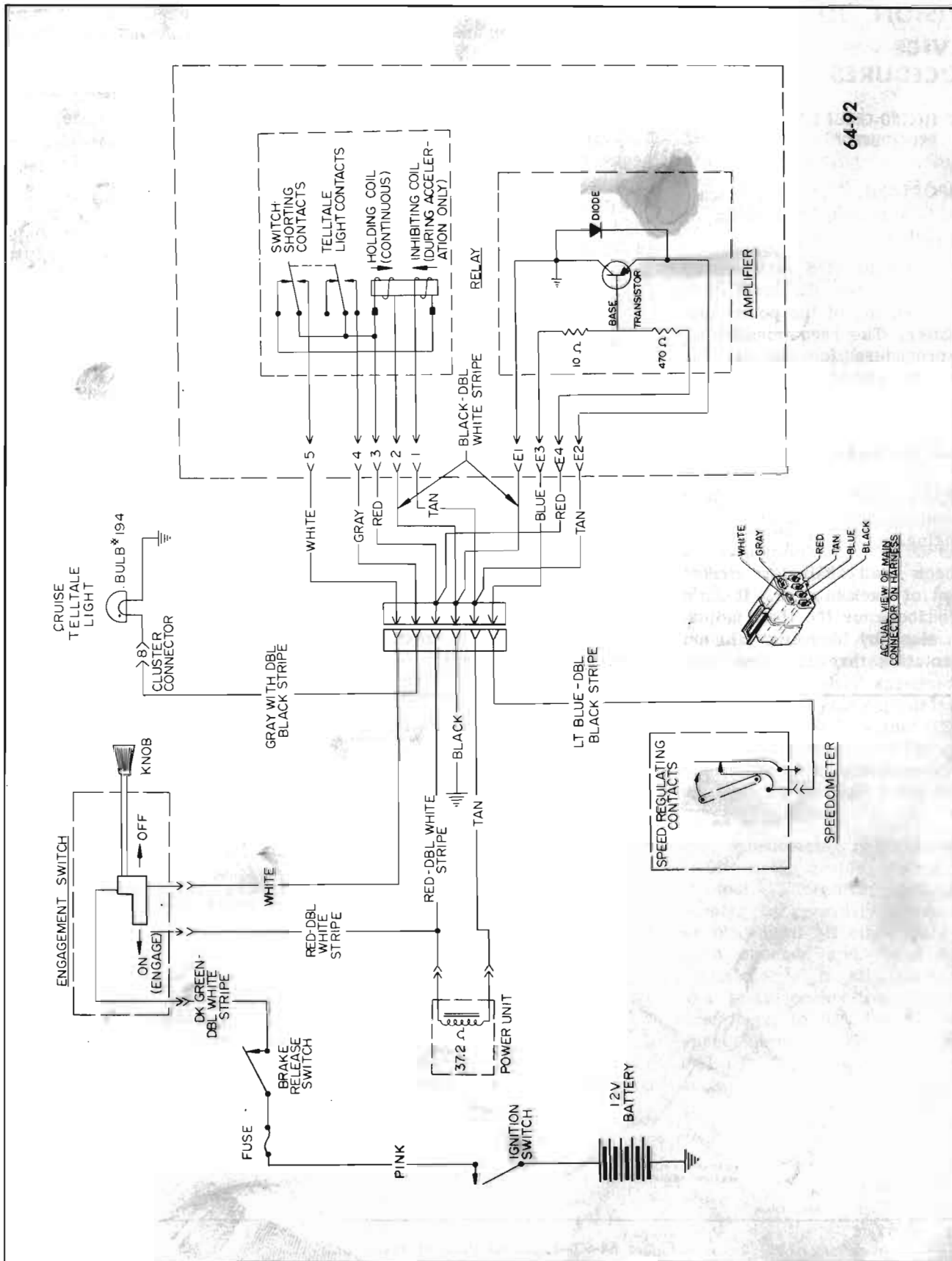

Figure 64-91—Cruise Control Wiring Diagram - LeSabre, Wildcat and Electra



64-92

Figure 64-92—Cruise Control Wiring Diagram - Riviera

## DIVISION III

### SERVICE PROCEDURES

#### 64-37 ELECTRO-CRUISE SERVICE PROCEDURES

**IMPORTANT:** Do not lubricate the power unit bead chain or its pulley.

The only scheduled maintenance required on the Electro-Cruise is the cleaning of the power unit air filter. The recommendations and procedure for cleaning the filter are listed in Group 00.

#### a. Power Unit Bead Chain Adjustment

1. Adjust engine hot idle speed to recommended setting, then shut off engine.

2. Check bead chain for correct amount of slack in chain. If chain is too loose or too tight, adjust chain slack by loosening jam nut and rotating threaded stud until

chain is just taut. Then back off stud two full turns and tighten jam nut.

#### b. Brake Release Switch Adjustment

1. Turn on ignition switch. Connect a test light between one terminal of brake release switch and ground; select terminal where light goes out when brake pedal is depressed.

2. Loosen screw that retains brake release switch to brake pedal support bracket. Position switch so that circuit opens (light goes out) when brake pedal is depressed 1/4 inch.

3. Tighten screw and recheck brake release switch adjustment.

#### c. Disassembly and Assembly of Power Unit

1. Disconnect forward end of bead chain by snapping it from ball. See Figure 64-93.

2. Remove wiring harness connector from power unit.

3. Remove engine vacuum and brake release switch hoses from power unit.

4. Remove screws holding power unit to cowl.

5. Depress diaphragm return spring and remove bead chain.

6. Remove eight screws from power unit and remove cover.

7. Remove control valve return spring by depressing with a knife blade and pushing sideways.

8. Remove control valve.

9. Remove air filter.

10. Wash power unit housing and cover using a good detergent.

11. Examine diaphragm for cracks or pin holes and replace if necessary.

12. Check control valve and seats for dirt, chips, burrs, wear or damage.

13. Clean or replace air filter as required.

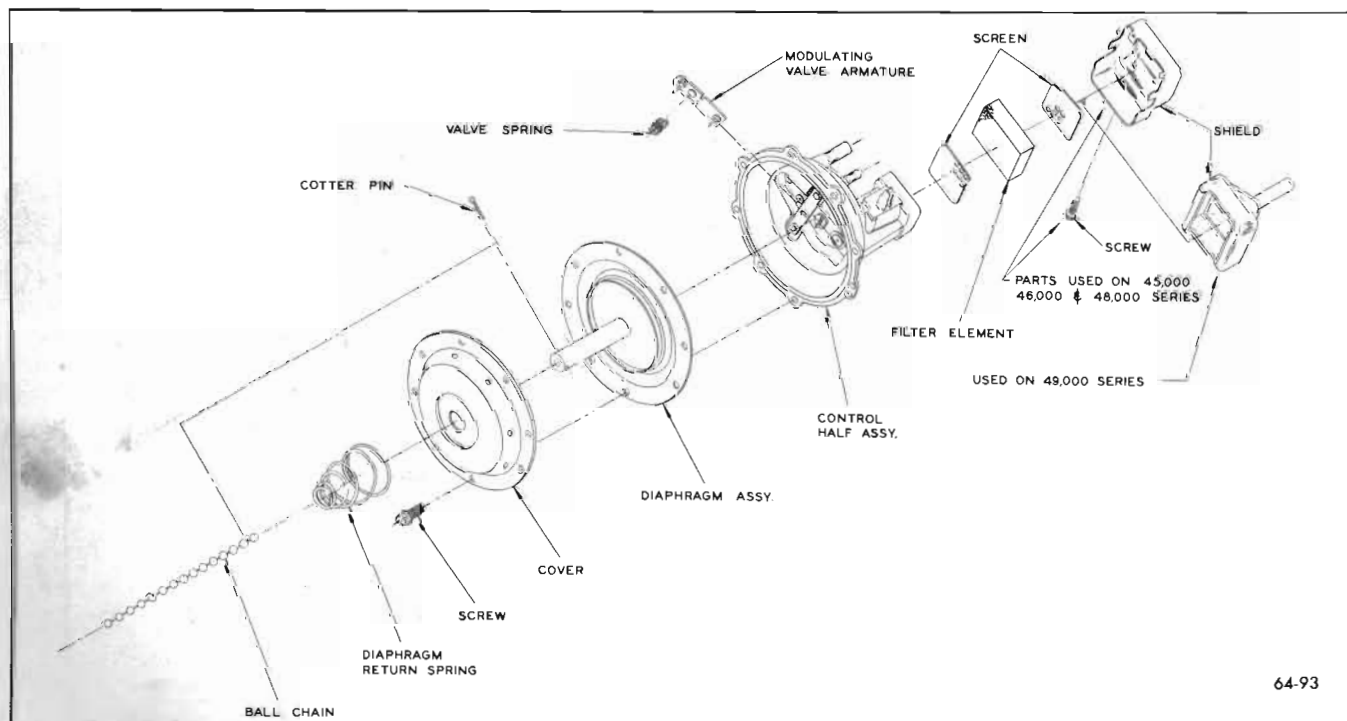

Figure 64-93—Exploded View of Power Unit

14. Reassemble by reversing disassembly procedure. Care must be taken to tighten screws alternately and evenly.

15. Reinstall power unit on car. Adjust bead chain (subpar. a) and leak test unit (par. 64-38, subpar. a).

## DIVISION IV

### TROUBLE DIAGNOSIS

#### 64-38 ELECTRO-CRUISE TROUBLE DIAGNOSIS

Whenever an Electro-Cruise complaint is encountered, find the complaint on the Trouble Diagnosis Chart and a number of possible causes will be found, listed in order of probability. In most cases, a road test to double-check the complaint will save time in the long run.

##### a. Power Unit Test

**IMPORTANT:** Check all vacuum hoses for proper attachment at vacuum source, power unit and brake release switch. See Figures 64-94 and 64-95.

1. Disconnect forward end of bead chain by snapping it from ball. Remove power unit air filter.
2. Check position of power unit diaphragm pull rod.
3. Start engine and again check position of diaphragm pull rod. If maximum pull-in is noted, disconnect wiring connector from power unit to eliminate possibility of an electrical problem. If rod is still pulled-in, remove power unit for repair.

4. With engine still running, hold finger over air inlet hole. If any diaphragm pull rod movement is noted, vacuum valve is leaking and power unit must be repaired.

5. With engine still running, push cruise engagement knob forward. If diaphragm pull rod moves into unit, proceed with Step 6. If rod does not move, remove wiring connector from power unit. Using jumper wires, connect one terminal to 12 volt source, connect other terminal to ground, and again check for pull rod movement. If unit does not operate, remove hose leading to brake release switch and hold finger on hose fitting on power unit. If power unit still does not operate, it is defective and must be repaired.

6. With power unit diaphragm rod pulled all the way in, clamp-off vacuum source hose. Leave hose clamped for 90 seconds. Any outward movement of rod in this period indicates leakage in the hose connections, in the brake release switch, in the diaphragm or through the air valve of the power unit.

7. If leakage is noted, remove brake release switch hose from power unit, plug fitting and repeat Steps 5 and 6. If diaphragm rod now remains stationary for 90 seconds, leakage is indicated in the brake release switch. If diaphragm still moves outward and all hose connections are okay, the power unit has an internal leak and must be repaired.

##### b. Relay Test

If trouble is indicated with the relay, substitute a known good

relay and test the car to see whether or not the trouble is now corrected.

##### c. Amplifier Test

If trouble is indicated with the amplifier, substitute a known good amplifier and test the car to see whether or not the trouble is now corrected.

##### d. Speedometer Tests

Trouble caused by the speedometer can be classified two ways: (1) erratic cruise control action. (2) no cruise control action. Tests for erratic cruise control action can only be made by driving the car on the road. However, a speedometer having a completely open circuit can be detected by pushing the engagement knob forward with the engine idling; the CRUISE light will come on but no cruise control action will result. To prove that the trouble is inside the speedometer, disconnect the cruise control wire from the speedometer, ground it, and again push the engagement knob. If the CRUISE light now stays off and the engine speeds up, the speedometer has an open circuit and must be removed for repair.

The speedometer is the most difficult of the cruise control units to test. Therefore, the speedometer is generally assumed to be okay until all other units have been checked and found to be satisfactory. If all other units and their connecting harnesses are found to be okay, then the speedometer should be removed and sent to an authorized repair station.



## ELECTRO-CRUISE TROUBLE DIAGNOSIS CHART

COMPLAINT	POSSIBLE CAUSE	ACTION TO BE TAKEN
A. Engine does not respond when Electro-Cruise knob is pushed in.	<ol style="list-style-type: none"> <li>1. Disconnected electrical connections or open in wiring.</li> <li>2. Blown fuses.</li> <li>3. Cruise release brake switch adjustment.</li> <li>4. Vacuum leakage or complete disconnection.</li> <li>5. Power unit coil open.</li> <li>6. Defective transistor amplifier.</li> </ol>	<p>Refer to Figures 64-94 or 64-95. Check for continuity using a test light at test points 1, 2, 3 and 4.</p> <p>Refer to Figures 64-91 or 64-92. Check for shorts, replace relay. Check accessories operating off same fuse.</p> <p>Adjust switch to open at 1/4 inch pedal depression.</p> <p>Refer to Power Unit Test.</p> <p>Energize coil directly from battery. If defective, replace.</p> <p>Replace and recheck.</p>
B. Cruise lamp comes on when Electro-Cruise knob is pushed, but no car response.	<ol style="list-style-type: none"> <li>1. Harness to speedometer unplugged or loose.</li> <li>2. Defective speedometer.</li> <li>3. Defective transistor amplifier.</li> <li>4. Defective relay.</li> </ol>	<p>Secure and recheck.</p> <p>Repair or replace and recheck.</p> <p>Replace and recheck.</p> <p>Replace and recheck.</p>
C. Electro-Cruise remains engaged when brake is depressed 1/2 in.	<ol style="list-style-type: none"> <li>1. Cruise release brake switch adjustment.</li> <li>2. Shorted cruise release brake switch.</li> <li>3. Shorted wire harness.</li> </ol>	<p>Adjust switch to open at 1/4 inch pedal depression.</p> <p>Remove short or replace if necessary.</p> <p>Make necessary corrections or replace.</p>
D. Blows fuses.	<ol style="list-style-type: none"> <li>1. Shorted wiring.</li> <li>2. Shorted relay, cruise lamp or power unit coil.</li> <li>3. Shorted transistor amplifier.</li> <li>4. Accessories on same fuse defective.</li> </ol>	<p>Make necessary corrections and recheck.</p> <p>Replace components and recheck.</p> <p>Replace and recheck.</p> <p>Check and correct.</p>

## ELECTRO CRUISE TROUBLE DIAGNOSIS CHART (CONT'D.)

COMPLAINT	POSSIBLE CAUSE	ACTION TO BE TAKEN
E. Engine races as soon as car is started when engage lever or knob is not pushed.	<ol style="list-style-type: none"> <li>1. Shorted wire harness.</li> <li>2. Shorted engage switch.</li> <li>3. Shorted relay.</li> <li>4. Vacuum orifice leak in power unit.</li> <li>5. Stuck accelerator linkage.</li> </ol>	<p>Make necessary corrections and recheck.</p> <p>Replace switch.</p> <p>Replace and recheck.</p> <p>Check per Power Unit Test.</p> <p>Correct as required.</p>
F. Electro-Cruise will not lock in after set speed is attained.	<ol style="list-style-type: none"> <li>1. Defective relay.</li> <li>2. Defective engage switch.</li> <li>3. Defective speedometer.</li> </ol>	<p>Replace and recheck.</p> <p>Replace switch.</p> <p>Repair or replace.</p>
G. Car keeps accelerating up past set speed.	<ol style="list-style-type: none"> <li>1. Shorted wire harness.</li> <li>2. Shorted speedometer.</li> <li>3. Defective relay.</li> <li>4. Defective transistor amplifier.</li> </ol>	<p>Make necessary corrections and recheck.</p> <p>Repair or replace and recheck.</p> <p>Replace and recheck.</p> <p>Replace and recheck.</p>
H. Automatically locks in Cruise when car goes over bumps.	<ol style="list-style-type: none"> <li>1. Loose junction block.</li> <li>2. Defective relay.</li> </ol>	<p>Secure junction block.</p> <p>Replace and recheck.</p>
I. Drops out of Cruise when car goes over bumps.	<ol style="list-style-type: none"> <li>1. Defective relay.</li> <li>2. Loose electrical connections.</li> <li>3. Cruise release brake switch adjustment.</li> <li>4. Loose junction block.</li> </ol>	<p>Replace and recheck.</p> <p>Secure and recheck.</p> <p>Adjust switch to open at 1/4 inch pedal depression.</p> <p>Secure junction block.</p>
J. Erratic cruise speed.	<ol style="list-style-type: none"> <li>1. Loose electrical connections.</li> <li>2. Defective speedometer.</li> <li>3. Defective power unit.</li> <li>4. Vacuum leakage.</li> </ol>	<p>Secure and recheck.</p> <p>Repair or replace.</p> <p>Refer to Power Unit Test.</p> <p>Refer to Power Unit Test.</p>

## ELECTRO CRUISE TROUBLE DIAGNOSIS CHART (CONT'D.)

COMPLAINT	POSSIBLE CAUSE	ACTION TO BE TAKEN
K. Slow response.	<ol style="list-style-type: none"> <li>1. Vacuum leakage.</li> <li>2. Defective power unit.</li> </ol>	<p>Refer to Power Unit Test.</p> <p>Repair or replace.</p>
L. Hunts at slow speed.	<ol style="list-style-type: none"> <li>1. Defective speedometer.</li> <li>2. Ball chain adjustment.</li> <li>3. Stiff accelerator linkage.</li> <li>4. Vacuum leakage.</li> <li>5. Dragging brakes.</li> <li>6. Kinked speedometer cable.</li> </ol>	<p>Repair or replace speedometer.</p> <p>Adjust and recheck.</p> <p>Adjust and recheck.</p> <p>Refer to Power Unit Test.</p> <p>Adjust and recheck.</p> <p>Replace.</p>
M. Does not disengage when engage lever is pulled out.	<ol style="list-style-type: none"> <li>1. Shorted wire harness.</li> <li>2. Shorted engage switch.</li> <li>3. Defective relay.</li> </ol>	<p>Make repairs and recheck.</p> <p>Replace and recheck.</p> <p>Replace and recheck.</p>
N. Cruise lamp does not light.	<ol style="list-style-type: none"> <li>1. Burned out or missing lamp bulb.</li> <li>2. Defective relay.</li> <li>3. Disconnected electrical connections or broken wiring.</li> </ol>	<p>Replace and recheck.</p> <p>Replace and recheck.</p> <p>Secure and recheck.</p>
O. Engine will not idle at slow speed when Electro-Cruise is not engaged.	<ol style="list-style-type: none"> <li>1. Vacuum leakage.</li> <li>2. Ball chain adjustment.</li> </ol>	<p>Refer to Power Unit Test.</p> <p>Adjust and recheck.</p>
P. Speed setting pointer and speedometer needle do not coincide when in cruise.	<ol style="list-style-type: none"> <li>1. Stiff throttle linkage.</li> <li>2. Vacuum leakage.</li> <li>3. Speedometer out of calibration.</li> </ol>	<p>Adjust and recheck.</p> <p>Refer to Power Unit Test.</p> <p>Repair or replace and recheck.</p>

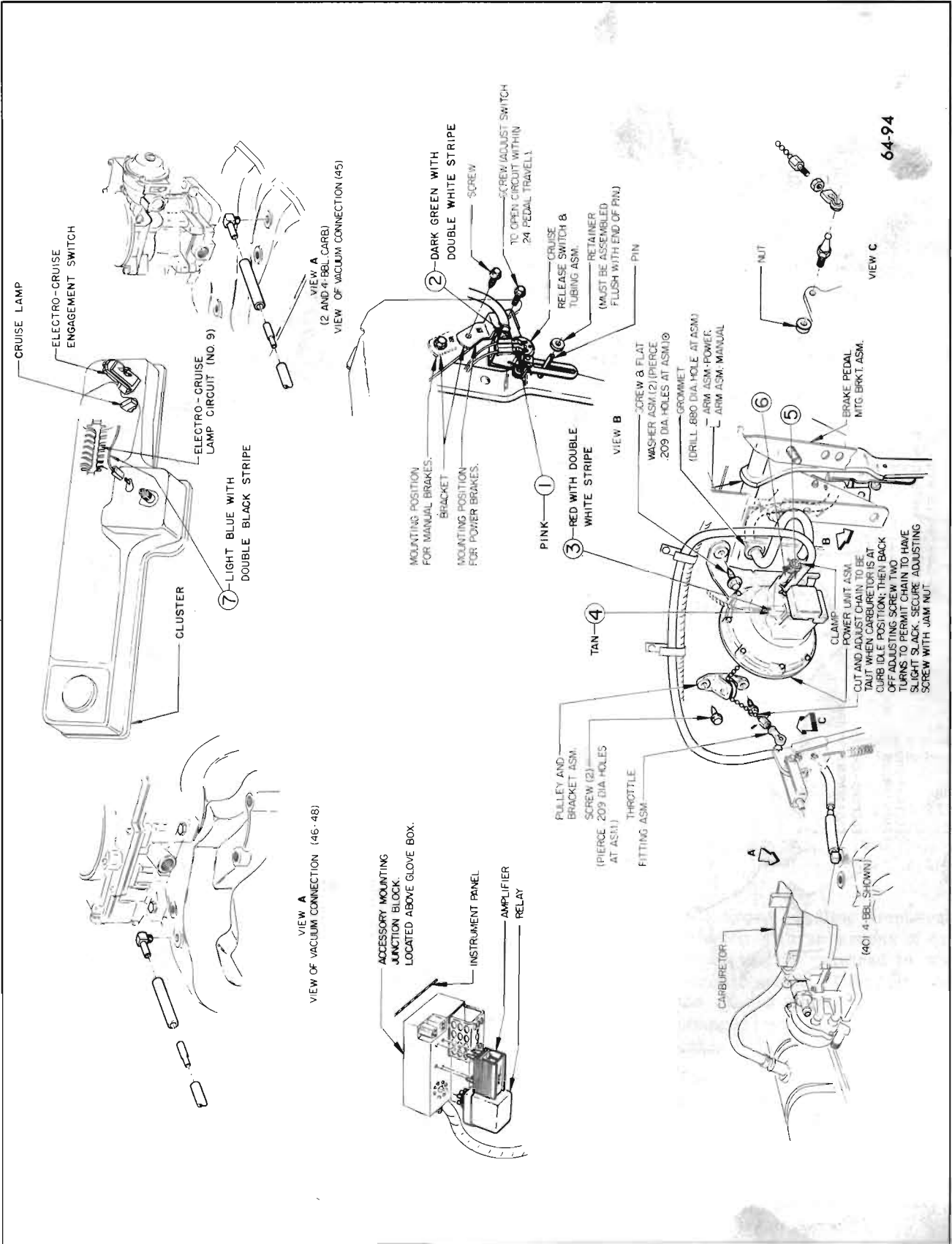
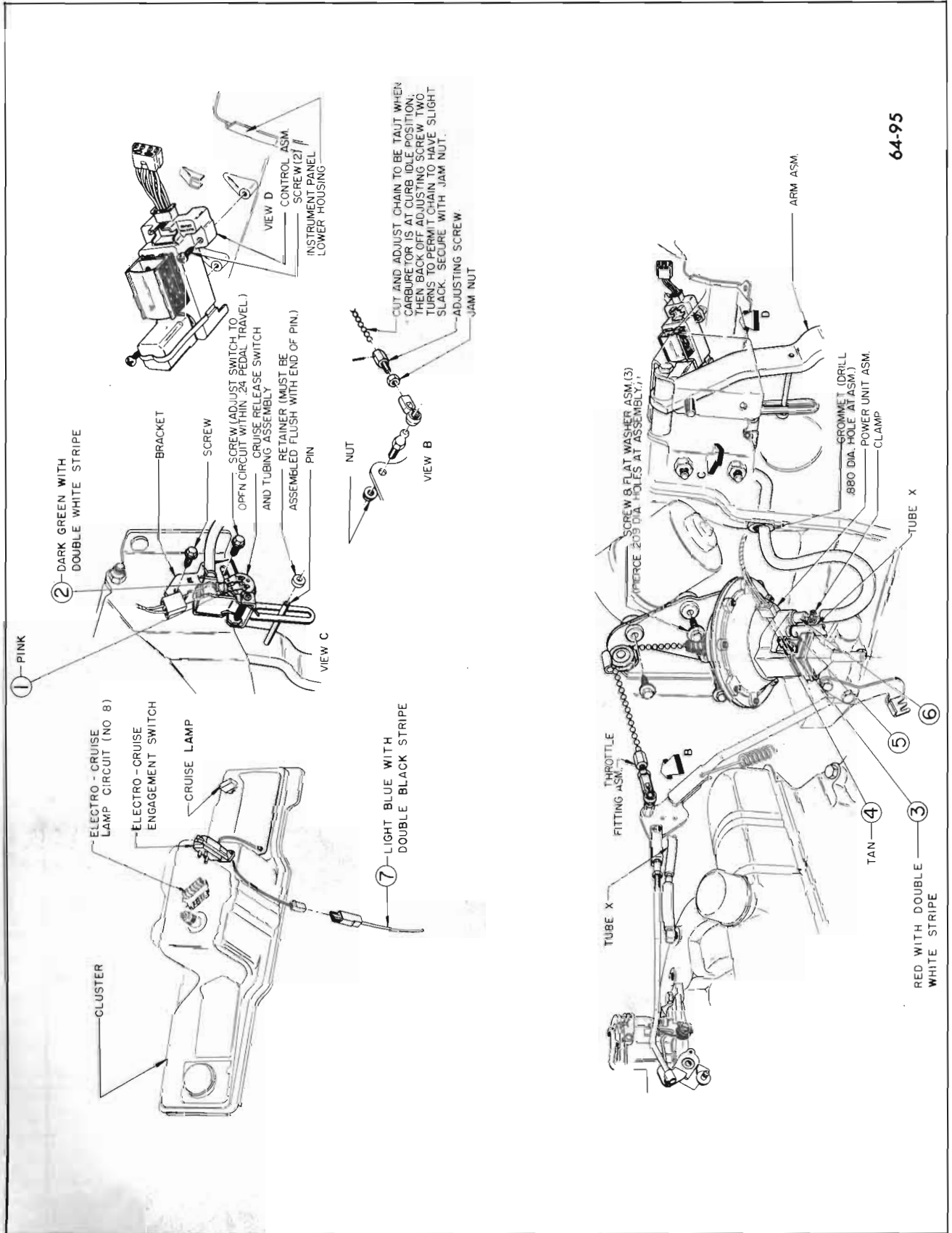

Figure 64-94—Electro-Cruise Installation - LeSabre, Wildcat and Electra



64-95

Figure 64-95—Electro-Cruise Installation - Riviera