

64-13 ROCHESTER 2GC CARBURETOR ADJUSTMENTS

	225 Eng. Man. Trans.	225 Eng. Auto. Trans.	225 Eng. Auto. Trans. California	300-340 Eng. Man. Trans.	300-340 Eng. Auto. Trans.	300 Eng. Auto. Trans. California	340 Eng. Auto. Trans. California
Choke Setting Index	1/2"	1/2"	1/2"	1/2"	1/2"	1/2"	1/2"
Float Level Adjustment	1-27/32"	1-27/32"	1-27/32"	1-27/32"	1-27/32"	1-27/32"	1-27/32"
Float Drop Adjustment	Outer Hole	Inner Hole	Inner Hole	Outer Hole	Inner Hole	Inner Hole	Inner Hole
Pump Rod Location	1-11/32"	1-5/32"	1-1/16"	1-11/32"	1-5/32"	1-5/32"	1-5/32"
Pump Rod Adjustment	.055"	.055"	.055"	.055"	.055"	.055"	.055"
Choke Rod Adjustment	.140"	.140"	.140"	.140"	.140"	.140"	.140"
Choke Unloader Adjustment	3 Turns In	3 Turns In	3 Turns In	3 Turns In	3 Turns In	3 Turns In	3 Turns In
Initial Idle Speed	2 Turns Out	2 Turns Out	2 Turns Out	2 Turns Out	2 Turns Out	2 Turns Out	1 Turn Out
Initial Idle Mixture							

DIVISION II

DESCRIPTION AND OPERATION

64-14 DESCRIPTION AND OPERATION OF ROCHESTER 2-BARREL CARBURETOR

a. General Description

The Rochester Model 2GC carburetor is of the side bowl design. While not interchangeable, the carburetors used on automatic and standard transmission cars are basically the same, and the description and service operations are identical. The only difference is in some of the internal calibrations. The carburetor float bowl is located forward of the main bores of the carburetor. The carburetor is compact in design in that all of the fuel metering is centrally located. See Figure 64-15.

This carburetor uses a calibrated cluster design, which places in

a removable assembly, the main well tubes, idle tubes, mixture passages, air bleeds and pump jets. This cluster can easily be removed for cleaning and inspection purposes. The cluster fits on a flat portion of the carburetor bowl in front of the main venturi with a gasket underneath. See Figure 64-15. The idle and main well tubes are permanently installed in the cluster body by means of a precision pressed fit and, therefore, cannot be serviced separately. The main nozzles and idle tubes are suspended in the fuel in the main wells of the float bowl.

The main metering jets are of the fixed type. Metering calibration is accomplished through a system of calibrated air bleeds which give the correct air/fuel mixtures throughout all operational ranges.

The Rochester Model 2GC carburetor employs the use of a vacuum operated power system for extra power when needed. Power

mixtures are regulated by drop in engine manifold vacuum regardless of the degree of throttle opening. Thereby, additional fuel can be supplied for power mixtures according to the engine demands.

The pump system has a vented type pump plunger. This is accomplished by means of a vapor vent ball in the pump plunger head. By venting the pump plunger, any fuel vapors which form in the pump well are vented to the fuel bowl during "hot" engine operation. This insures that the pump well and passages will be primed with solid fuel at all times, thereby improving accelerator pump action.

The carburetor is internally vented through a hole in the air horn and is externally vented through a capped vent hole located in the center of the carburetor air horn just above the float bowl.

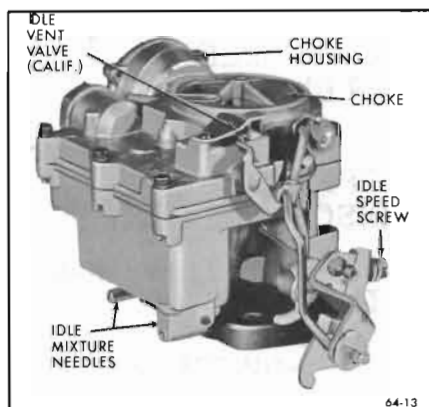

Figure 64-13—Rochester 2GC Carburetor Assembly - 225 Engine

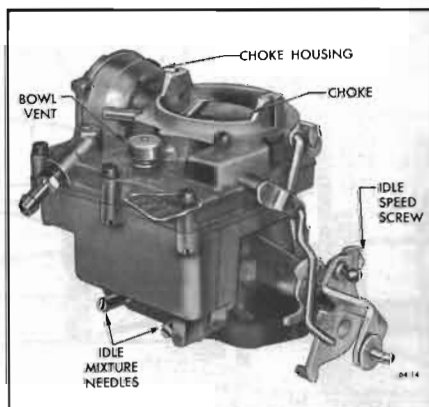

Figure 64-14—Rochester 2GC Carburetor Assembly - 300-340 Engine

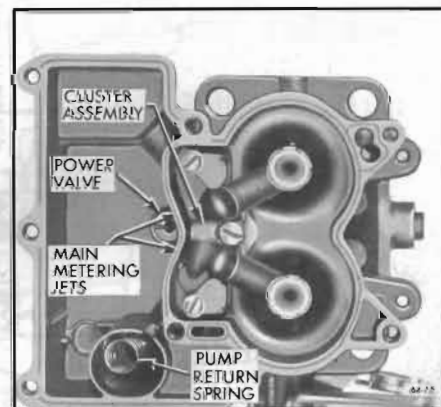

Figure 64-15—Main Body Parts

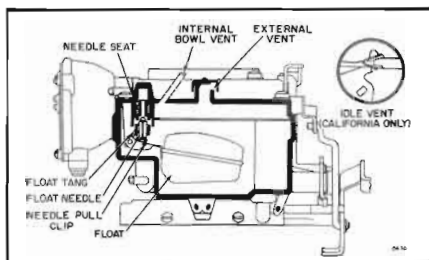

Figure 64-16—Float System

Adjustments have been made as simple as possible. They consist of idle, float level, float drop, pump, fast idle, choke, choke rod and choke unloader adjustments only.

Incorporated in the Rochester Model 2GC carburetor are six basic systems. They are Float, Low Speed, Main Metering, Power, Accelerating and Choke systems. The following explanation

and illustrations show that each system operates to provide efficient carburetion through all operating conditions.

b. Operation of Float System

The float system controls the level of the fuel in the carburetor fuel bowl. Fuel level is very important because it must be maintained to give proper metering through all operating ranges.

Fuel entering the carburetor must first pass through the inlet screen, by the inlet needle seat, then past the float needle, into the float bowl; flow continues until the fuel level raises the float to a position where it closes the float valve. As fuel is used from the carburetor bowl the float drops, moving the float needle off

its seat and replenishing the fuel in the bowl, thereby keeping the fuel level constant. See Figure 64-16.

A float tang located at the rear of the float arm between the float hangers prevents the float assembly from moving too far downward, but allows the float assembly to move down far enough for maximum fuel flow into the carburetor bowl. A float needle pull clip connecting the float arm to the needle valve keeps the needle from sticking closed in the seat, which may be caused by dirt or gum formation.

An external vent located on the top of the carburetor air horn vents any fuel vapors which may form in the float bowl to the outside atmosphere during periods of hot engine operation. This helps prevent poor hot engine idling and hard hot engine starting.

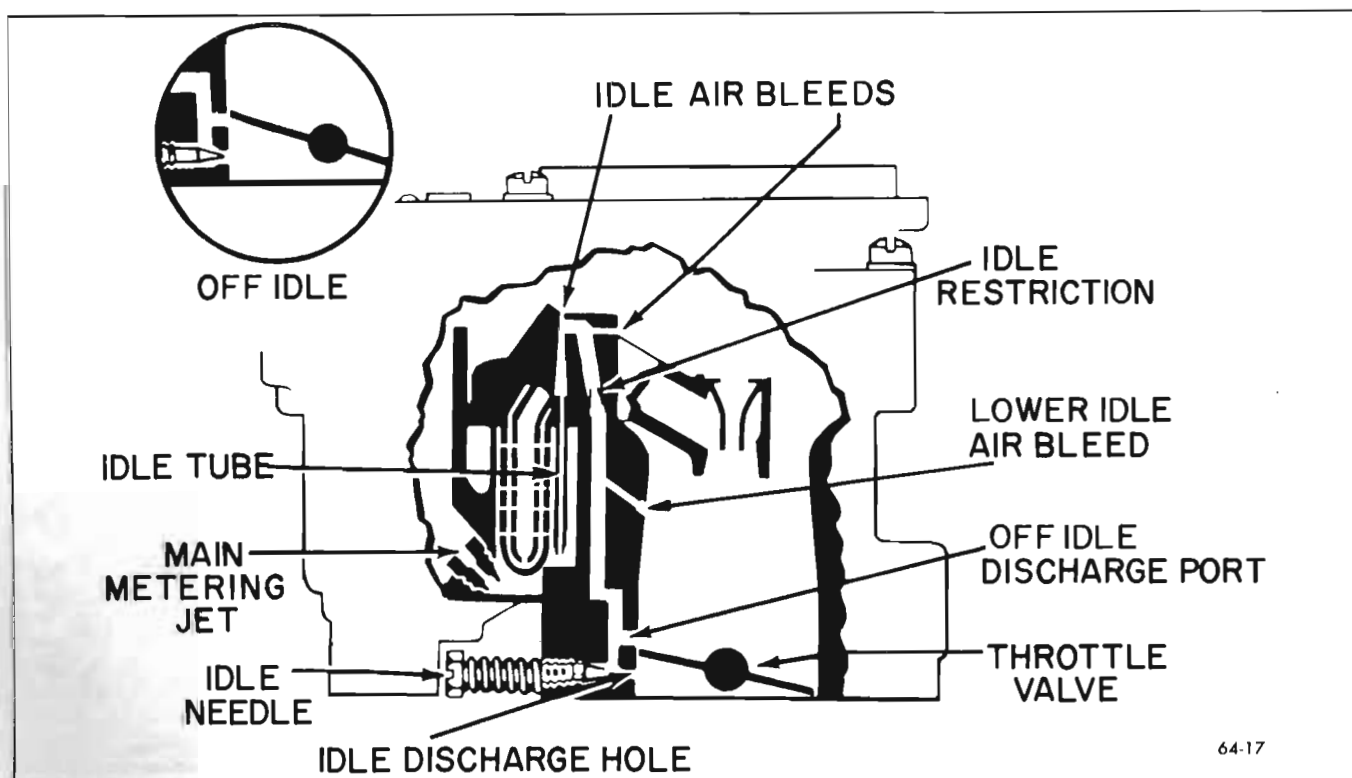

Figure 64-17—Low Speed System

c. Operation of Idle (Low Speed) System

During engine idle operation, air flow through the carburetor venturi is very low and is not great enough to cause fuel to flow from the main discharge nozzles. Therefore, the idle system is used to provide the proper mixture ratios required during idle and low speed operation of the engine.

The idle system consists of the idle tubes, idle passages, idle air bleeds, idle adjustment needles, off-idle discharge slots and the idle adjusting needle holes.

In idle speed position, each throttle valve is slightly open, allowing a small amount of air to pass between the wall of the carburetor bore and the edge of the throttle valve. Since there is not enough air flow for venturi action, the fuel is made to flow by the application of vacuum (low pressure) directly through the idle system to the fuel in the carburetor bowl. See Figure 64-17.

Fuel from the float bowl passes through each main metering jet into the main well where it is metered by the orifice at the

lower end of the idle tube. It then passes up the idle tube and is mixed with air at the top of the idle tube by two calibrated idle air bleeds. The air/fuel mixture then passes down through a calibrated restriction into a vertical passage past a third idle bleed to the idle port located just above each closed throttle valve. Here the mixture is again bled with air and then moves down to the idle needle hole where it combines with air by-passing the slightly open throttle valve. The idle mixture needle controls the amount of fuel mixture which enters the carburetor bore at curb idle position of the throttle valve.

As the throttle valve is opened further, more and more of the idle port is exposed to manifold vacuum. This port supplies additional fuel mixture for off-idle engine requirements.

On all air conditioner equipped cars, a special thermostatic air valve is added in the hole in the rear side of the throttle body. This valve is designed to compensate for loss of engine RPM

while idling under very hot operating conditions. When the underhood temperature rises beyond a certain point, the calibrated thermostatic spring opens the valve. This allows additional air to flow in below the throttle valves. At normal operating temperatures, the valve should be closed. The valve cannot be adjusted or repaired; therefore, a faulty valve must be replaced.

d. Operation of Main Metering (High Speed) System

As the throttle valve continues to open, the edge of the throttle valve is gradually moved away from the wall of the carburetor bore, reducing the vacuum so that the discharge of fuel mixture at the idle needle hole and off-idle port gradually diminishes.

With the increased throttle opening, there is increased velocity in the venturi system. This causes a drop in pressure in the large venturi which is increased many times in the small venturi. Since the low pressure (high

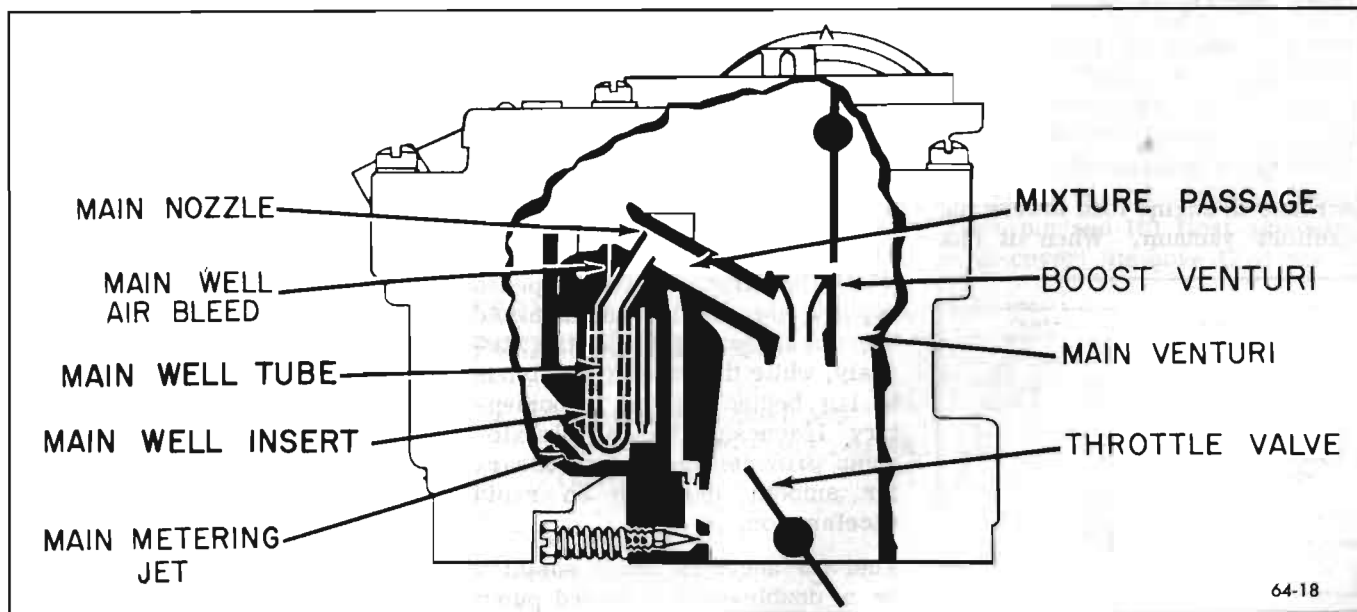

Figure 64-18—High Speed System

vacuum) is now in the small venturi, fuel will flow in the following manner:

Fuel from the float bowl passes through the main metering jets into the main well and rises in the main well tubes. Air entering the main well through the main well bleeds is mixed with fuel through calibrated holes in the main well tube. The mixture then moves up and out of the discharge nozzle into a channel where more air is added. The mixture travels down through the channel to the small venturi where it is delivered to the air stream and then to the intake manifold. See Figure 64-18.

e. Operation of Power System

To achieve the proper mixtures required when more power is desired or for extreme high speed driving, a vacuum operated power piston in the air horn and a power valve located in the bottom of the float bowl are used. Through a connecting vacuum passage from the base of the carburetor to the power piston cylinder in the air horn, the power piston is exposed to manifold vacuum at all times. See Figure 64-19.

During idle and part throttle operation, the relatively high vacuum holds the power piston up against spring tension and the power valve remains closed.

Increase in engine load lowers the manifold vacuum. When it has

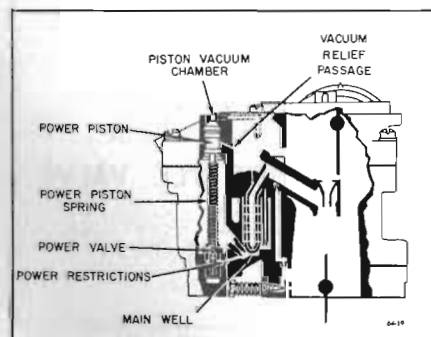

Figure 64-19—Power System

dropped sufficiently the power piston spring overcomes the upward vacuum pull and the power piston moves downward, opening the power valve to allow additional fuel to flow through calibrated restrictions into the main well.

As the engine load decreases, the resulting higher vacuum overcomes the spring tension on the power piston and raises the power piston closing the power valve.

A 2-stage power valve is used. In the first stage, fuel is metered by the valve itself. This stage is used for light power loads. On heavy power loads the valve is fully opened to the second stage, and in this location the power valve allows the fuel to be metered by the power restrictions in the fuel channel located in the bottom of the fuel bowl.

It will be noted that the power piston cavity in the carburetor air horn is connected to the main air flow passage by a vacuum relief passage. It is the purpose of this passage to prevent the transfer of vacuum acting on the piston from acting also on the top of the fuel in the float bowl. Any leakage of air past the upper grooves of the piston will be compensated for by this relief passage and will not affect carburetor metering.

f. Operation of Accelerating System

When the throttle valve is opened rapidly, the air flow and manifold vacuum change almost instantaneously, while the heavier fuel tends to lag behind causing a momentary leanness. The accelerator pump provides the fuel necessary for smooth operation on rapid acceleration.

Fuel for acceleration is supplied by a double-spring loaded pump plunger. The top and bottom springs combine to move the

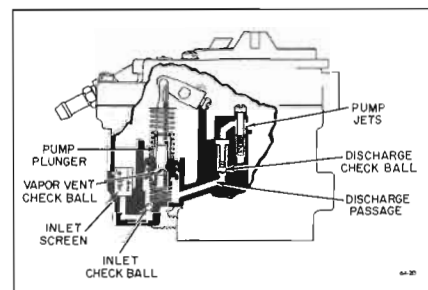

Figure 64-20—Accelerating Pump System

pump plunger so that a smooth, sustained charge of fuel is delivered for acceleration.

Fuel is drawn into the pump well through the inlet ball check on the intake stroke of the pump plunger (upward stroke). See Figure 64-20.

Downward motion of the pump plunger seats the inlet ball check and forces the fuel through the discharge passage where it unseats the pump discharge ball and then passes on through to the pump jets where it sprays into the venturi.

The ball check located in the pump plunger head serves as a vapor vent for the pump well. Without this vent, vapor pressure in the pump well might force fuel from the pump system into the engine manifold causing hard starting when the engine is hot.

There is an inner hole in the pump lever to provide a richer pump adjustment for extreme cold temperature conditions. This inner hole should be used only when low temperature hesitation indicates a too lean pump setting.

The pump discharge ball check in the accelerator pump passage prevents any pullover or discharge of fuel from the pump nozzles when the accelerator pump is inoperative.

g. Operation of Choke System

The choke system is composed of a thermostatic coil, vacuum choke

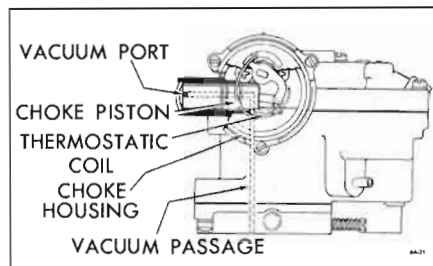

Figure 64-21—Choke System

piston, offset choke valve, fast idle cam and choke linkage. Its operation is controlled by a combination of intake manifold vacuum, the offset choke valve, atmospheric temperature and exhaust manifold heat. See Figure 64-21.

The choke thermostatic coil is calibrated to hold the choke valve closed when the engine is cold. When the engine is started, air velocity against the offset choke valve causes the valve to open slightly against the torque of the thermostatic coil. In addition, intake manifold vacuum applied to the choke piston through the vacuum passage tends to open the choke valve. Vacuum pull on the choke piston is offset by the tension of the thermostatic coil. As the engine warms up, heated air is drawn into the choke housing through the choke heat tube through a passage in the choke housing. As the engine temperature increases, it causes the thermostatic coil to relax its tension, which together with vacuum pull on the choke piston and air flow against the offset choke valve causes the choke valve to open gradually until the engine is thoroughly warmed up, at which point the choke valve is fully opened.

Automatic choke failure due to build-up of dust or other foreign material in the choke housing is a common service item. This dirt is trapped from the air which is continually passing through the choke whenever the engine is running.

In past models, air for the choke was taken in at the rear end of a pipe passing through the exhaust manifold passage, then up to the choke housing through an insulated pipe. This part of the choke heat system remains the same; however, all Buicks now have a clean air pipe which conducts filtered air from the carburetor air horn to the intake end of the exhaust manifold pipe. Since nothing but filtered air passes through the choke housing with this new system, the action of the automatic choke remains trouble-free for a much longer period of use.

A mechanical choke unloader is incorporated to open the choke valve slightly when the engine is cold. The choke unloader provides a means for opening the choke valve to correct any loading condition encountered during cold starting.

To prevent stalling during the warm-up period, it is necessary to run the engine at a slightly higher idle speed than for a warm engine. This is accomplished by steps on the fast idle cam. The fast idle cam is in turn linked to the choke valve shaft by the choke rod, choke trip lever and choke lever and collar assembly. This holds the throttle valves open sufficiently during the warm-up period to give increased idle RPM until the choke valve moves to the fully open position and the engine is thoroughly warmed up.

DIVISION III

SERVICE PROCEDURES

64-15 DISASSEMBLY, CLEANING AND INSPECTION OF ROCHESTER 2-BARREL CARBURETOR

a. Choke Disassembly and Removal of Air Horn

1. Mount carburetor on a proper mounting fixture such as J-5923.

2. Remove three choke cover attaching screws and retainers. Remove choke cover assembly, gasket and insulator baffle inside the choke housing.

3. Remove choke piston and lever assembly from the end of the choke shaft in the choke housing by removing retaining screw in the end of the choke shaft. Rotate choke piston lever to remove choke piston from bore in choke housing. Choke piston can now be removed from the lever by shaking piston pin into palm of hand.

4. Remove two Phillips choke housing attaching screws, then remove the choke housing and gasket from the air horn.

5. Remove pump rod by removing upper and lower retaining clips.

6. Remove fast idle cam attaching screw. Then remove fast idle cam and rod assembly by rotating until lug on upper end of choke rod passes through slot in the upper choke lever and collar assembly. The lower end of choke rod can be removed from fast idle cam in the same manner.

7. Remove air horn attaching screws and carefully remove air horn assembly from float bowl by lifting gently upward.

b. Disassembly of Air Horn

1. Place air horn assembly inverted on bench. Remove float hinge pin and lift float assembly from cover. Remove float needle

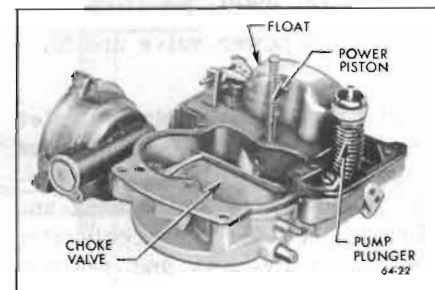

Figure 64-22—Air Horn Parts

from the float arm. Remove float needle seat, fibre gasket and needle seat screen. See Figure 64-22.

2. Remove power piston by depressing shaft and allowing spring to snap repeatedly, thus forcing the power piston retaining washer from casting.

NOTE: If heavy staking is encountered, remove staking from around power piston retaining washer.

3. Remove retainer on the end of pump plunger shaft, then remove pump assembly from pump inner arm. Remove pump lever and shaft assembly by loosening set screw on inner arm and removing outer lever and shaft.

4. Remove air horn gasket.

5. Remove two choke valve retaining screws, then remove choke valve from choke shaft. Remove choke shaft from air horn, then choke lever and collar assembly can be removed from choke shaft.

Note position of the choke lever in relation to the choke trip lever on the end of the choke shaft for ease in reassembly.

c. Disassembly of Float Bowl

1. Remove pump plunger return spring from pump well. Remove small aluminum check ball from the bottom of pump well by inverting bowl and shaking into hand. Remove pump inlet screen from bottom of fuel bowl.

2. Remove main metering jets.

3. Remove power valve and fibre gasket.

4. Remove three venturi cluster attaching screws and remove cluster and gasket. Center cluster screw has smooth shank and fibre gasket for the accelerator pump fuel by-pass and sealing.

5. Using a pair of long nosed pliers remove pump discharge

ball spring "T" shaped retainer. Then remove pump discharge spring and steel discharge ball.

6. Remove two main well inserts in the main well.

7. Invert carburetor and remove three throttle body to bowl attaching screws. Remove throttle body and throttle body to bowl gasket.

d. Disassembly of Throttle Body

1. Remove idle mixture adjusting needles and springs.

No further disassembly of the throttle body is needed. The throttle valves should never be removed as the idle and spark holes are drilled in direct relation to the location of the throttle valves and shaft. Removal of the throttle valves will upset this location. The throttle body assembly is only serviced as a complete unit with throttle valves intact.

e. Cleaning and Inspection

Dirt, gum, water or carbon contamination in or on the exterior moving parts of a carburetor are often responsible for unsatisfactory performance. For this reason, efficient carburetion depends upon careful cleaning and inspection while servicing.

1. Thoroughly clean carburetor castings and metal parts in carburetor cleaning solvent.

CAUTION: Pump plunger or any fiber or rubber parts should never be immersed in carburetor cleaner. Wash pump plunger in clean solvent.

2. Blow out all passages in the castings with compressed air and blow off all parts until they are dry. Make sure all jets and passages are clean. Do not use wires for cleaning fuel passages or air bleeds.

3. Check all parts for wear. If wear is noted, defective parts must be replaced. Note especially the following:

(a) Check float needle and seat for wear. If wear is noted, the assembly must be replaced.

(b) Check float hinge pin for wear and float for dents or distortion. Check float for fuel leaks by shaking.

(c) Check throttle and choke shaft bores for wear and out of round.

(d) Inspect idle mixture adjusting needles for burrs or grooves. Such a condition requires replacement.

(e) Inspect pump plunger cup; replace if damaged, worn, or hard.

(f) Inspect pump well in bowl for wear or scoring.

4. Check filter screens for dirt or lint. Clean, and if they remain plugged, replace.

5. If for any reason, parts have become loose or damaged in the cluster casting, the cluster assembly must be replaced.

6. It is recommended that new gaskets be used whenever the carburetor is disassembled or overhauled.

64-16 ASSEMBLY OF ROCHESTER 2-BARREL CARBUETOR

a. Assembly of Throttle Body

1. Screw idle mixture adjusting needles and springs into the throttle body until finger tight. Back out screw one turn as a preliminary idle adjustment.

CAUTION: Do not force idle needle against its seat or damage may result.

2. Invert float bowl assembly and place the new throttle body gasket on bowl. Install throttle body on bowl using three screws and lock washers. Tighten securely.

b. Assembly of Float Bowl

1. Drop steel pump discharge check ball into discharge hole. Install pump discharge spring and "T" shaped retainer, staking retainer in place.

NOTE: Top of retainer must be flush with flat of bowl casting.

2. Install two main well inserts. Align flat on lip of insert with flat in recess on top of main well. Install venturi cluster with gasket. Install venturi cluster screws and tighten evenly and securely. Make sure center screw is fitted with fibre gasket and special smooth shank screw is used.

3. Install two main metering jets, power valve gasket and power valve.

4. Install small aluminum inlet check ball in pump inlet in the bottom of pump well; insert pump return spring and center in well by pressing downward with finger.

5. Install pump inlet screen in the bottom of float bowl.

c. Assembly of Air Horn

1. Place new choke housing gasket in position on choke housing and install choke housing using two Phillips head attaching screws.

2. Install choke lever and collar onto choke shaft. Tang on choke lever faces away from air horn and is on top of choke trip lever.

3. Install choke shaft and lever assembly into air horn. Choke rod hole in the choke lever faces fuel inlet side of carburetor.

4. Install choke valve in choke shaft so that letters "RP" will face upward in finished carburetor. Install two new choke valve attaching screws but do not tighten securely until choke valve is centered. Center choke valve on choke shaft by holding choke

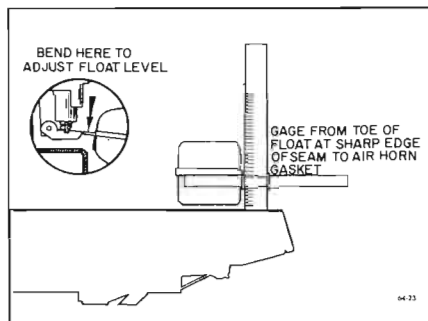

Figure 64-23—Float Level Adjustment

valve tightly closed; then slide choke shaft in to obtain approximately .020 clearance between choke trip lever and choke lever and collar assembly. Tighten choke valve screws securely and stake lightly in place. Choke valve will be perfectly free in all positions when installed correctly.

5. Install outer pump lever and shaft assembly into air horn with lever pointing toward choke shaft. Install inner pump arm with plunger hole inward and tighten set screw securely.

6. Attach pump plunger assembly to the inner pump arm with pump shaft off set pointing inward and install retainer.

7. Install needle seat screen on the needle seat and assemble float needle seat and gasket in air

horn. Tighten needle seat securely, using a wide bladed screwdriver.

8. Install power piston into vacuum cavity. Lightly stake piston retainer washer in place. Piston should travel freely in cavity.

9. Install air horn gasket on air horn, fitting gasket over guide pin.

10. Attach float needle to float. Carefully position float and insert float hinge pin. Drop tang on rear of float arm should point downward toward air horn.

11. Fuel inlet fitting should be installed if removed.

12. Float level adjustment.

With air horn assembly inverted, measure the distance from the air horn gasket to lower edge (sharp edge) of float seam at end of float, as shown. Bend float arm as required to adjust float level. See Figure 64-23.

13. Float drop adjustment.

With air horn assembly held upright, measure distance from gasket to bottom of float pontoon at outer end, as shown. Bend float tang as required to adjust float drop, as shown in Figure 64-24.

14. Carefully place air horn assembly on float bowl, making

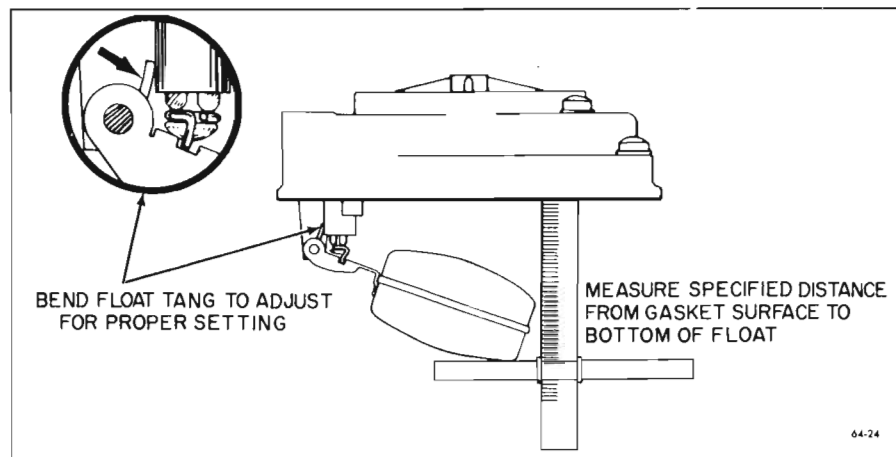

Figure 64-24—Float Drop Adjustment

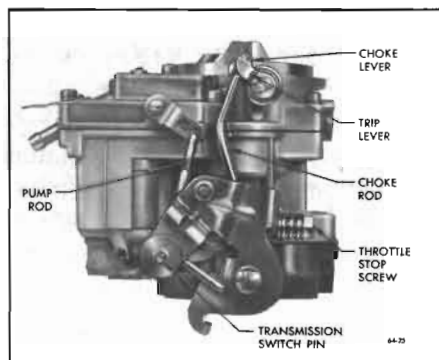

Figure 64-25—Choke Linkage

certain that the pump plunger is properly positioned in the pump well. Lower the cover gently, straight down, then install air horn to float bowl attaching screws. Tighten evenly and securely.

NOTE: Longer air horn screw goes in top of pump housing.

15. Install choke rod into choke lever and fast idle cam. Install fast idle cam screw and tighten securely. See Figure 64-25 for proper installation.

16. Install accelerator pump rod in outer hole and into throttle lever and install retainers.

17. Assemble choke piston to the choke lever and link assembly, retaining with piston pin. Piston pin hole in side of choke piston faces toward air horn. Install choke piston into choke housing bore and attach choke piston lever to the end of the choke shaft, making sure flats on lever line

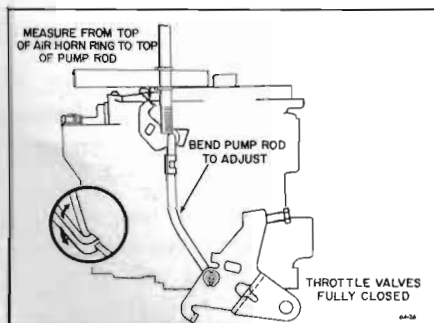

Figure 64-26—Pump Rod Adjustment

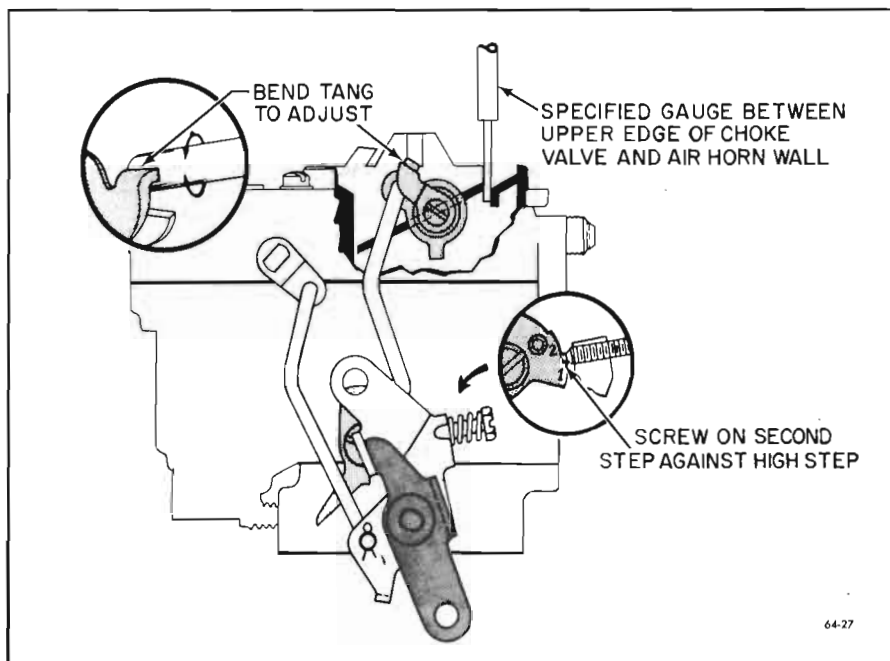

Figure 64-27—Choke Rod Adjustment

up with flats on choke shaft. Install retaining screw and tighten securely.

18. Install insulator baffle into choke housing.

19. Install new gasket on choke cover assembly; then install assembly to choke housing rotating counterclockwise until the thermostatic coil picks up the choke piston lever and closes the choke valve. Rotate cover until index mark on cover aligns with the index mark on choke housing.

20. Install three choke cover retaining screws and retainers and tighten securely. With the index markings aligned, the choke valve should be lightly closed at 75°F.

64-17 EXTERNAL ADJUSTMENT OF ROCHESTER 2-BARREL CARBURETOR

All adjustments on the carburetor, except for float adjustments, are made externally. For float level and drop adjustments, see Steps 12 and 13.

a. Pump Rod Adjustment

Back out idle stop screw and completely close throttle valve

in bore. Place pump gauge across top of carburetor air horn ring, as shown, with leg of gauge pointing downwards towards top of pump rod. Lower edge of gauge leg should just touch the top of the pump rod. Bend the pump rod as required to obtain the proper setting using Tool J-4552. See Figure 64-26.

b. Choke Rod Adjustment

With idle stop screw in normal idle position, place idle stop screw on the second step of the

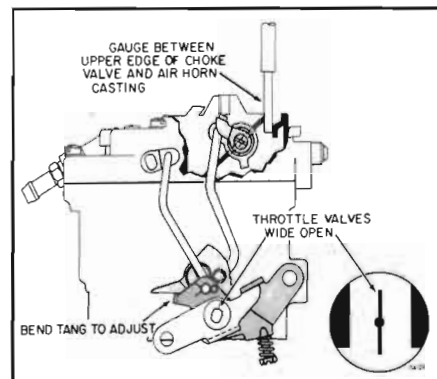

Figure 64-28—Choke Unloader Adjustment

fast idle cam against shoulder of the high step. Wire gauge should just go between upper edge of choke valve and wall of air horn. Bend tang on choke lever to obtain correct choke rod setting. See Figure 64-27.

c. Choke Unloader Adjustment

With throttle valves held wide open, choke valve should be opened enough to admit end of gauge between upper edge of choke valve and inner air horn wall. Bend unloader tang on throttle lever to obtain proper clearance. See Figure 64-28.

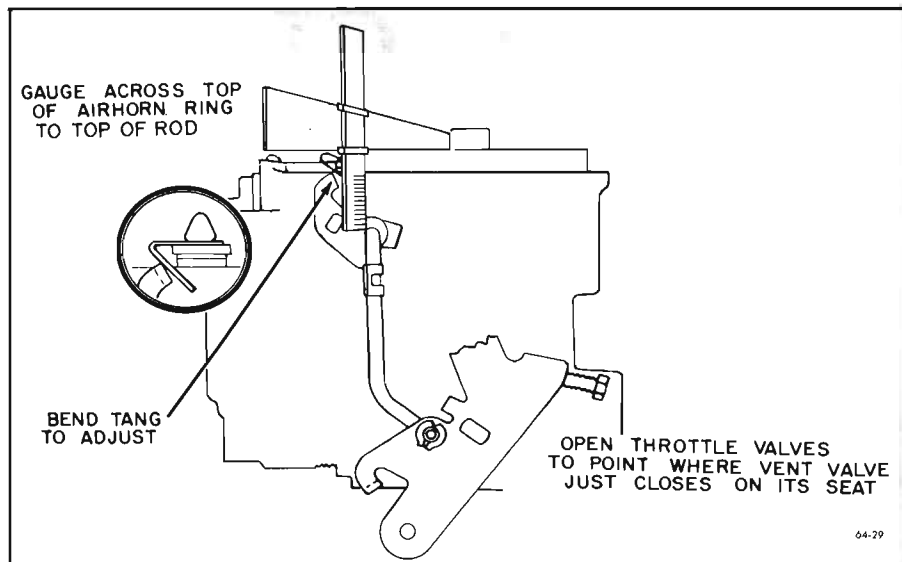

Figure 64-29—Idle Vent Adjustment

d. Slow Idle Adjustment

Adjust slow idle in drive to 550 RPM (add 50 RPM for air conditioner). When engine is at normal operating temperature, adjust idle mixture needle screws; readjust idle speed if necessary. See paragraph 64-2.

e. Fast Idle Adjustment

A fast idle speed adjustment is not required because fast idle is controlled by the throttle stop screw. If the idle speed is correctly set and the choke rod properly adjusted, the fast idle will be maintained.

f. Idle Vent Adjustment

Open throttle to point where idle vent valve just closes. With adjustable T-scale, measure distance from top of air horn ring to top of pump rod. Bend idle vent tang to adjust. See Figure 64-29.