

# SECTION B

## 300 AND 340 CUBIC INCH V-8 ENGINES

### CONTENTS OF SECTION B

Division	Paragraph	Subject	Page
I		SPECIFICATIONS AND ADJUSTMENTS:	
	60-1	Bolt Torque Specifications . . . . .	60-44
	60-2	General Specifications . . . . .	60-45
	60-3	Engine Dimensions and Fits . . . . .	60-47
	60-4	Engine Tune-Up and Adjustments . . . . .	60-48
II		DESCRIPTION AND OPERATION:	
	60-5	Engine Construction . . . . .	60-50
	60-6	Lubrication System . . . . .	60-56
	60-7	Cooling System . . . . .	60-58
III		SERVICE PROCEDURES:	
	61-1	Cylinder Heads, Valves, and Lifters . . . . .	60-59
	61-2	Connecting Rod Bearings . . . . .	60-66
	61-3	Crankshaft Bearings and Seals . . . . .	60-67
	61-4	Pistons, Rings, and Connecting Rods . . . . .	60-69
	61-5	Camshaft and Timing Chain . . . . .	60-73
	62-1	Oil Pump and Lubrication System . . . . .	60-76
	62-2	Positive Crankcase Ventilation . . . . .	60-77
	63-1	Water Pump and Lubrication System . . . . .	60-78
	63-2	Intake and Exhaust Manifolds . . . . .	60-81
	63-3	Engine Mounting, Flywheel and Engine Balancing . . . . .	60-82
IV		TROUBLE DIAGNOSIS:	
	63-9	Excessive Oil Consumption . . . . .	60-87
	63-10	Noisy Valves and Lifters . . . . .	60-88
	63-11	Cooling System Trouble . . . . .	60-89

## DIVISION I SPECIFICATIONS AND ADJUSTMENTS

### 60-1 BOLT TORQUE SPECIFICATIONS

Use a reliable torque wrench to obtain the figures listed below. This will prevent straining or distorting the parts as well as preventing thread damage. These specifications are for clean and lightly lubricated threads only. Dry or dirty threads produce friction which prevents accurate measurement of the actual torque. It is important that these specifications be strictly observed. Overtightening can damage threads. This will prevent attainment of the proper torque and will require replacement of the damaged part.

**60-1 BOLT TORQUE SPECIFICATIONS (Cont'd.)**

Area	Torque Lb. Ft.
Spark Plugs . . . . .	25-35
Crankshaft Bearing Caps to Cylinder Block . . . . .	95-120
Connecting Rods . . . . .	30-40
Cylinder Head to Cylinder Block . . . . .	65-80
Harmonic Balancer to Crankshaft . . . . .	140 Minimum
Fan Driving Pulley to Harmonic Balancer . . . . .	18-25
Flywheel to Crankshaft (Auto & Manual) . . . . .	50-65
Oil Pan to Cylinder Block . . . . .	9-13
Oil Pan Drain Plug . . . . .	25-35
Oil Pump Cover to Timing Chain Cover . . . . .	8-12
Oil Pump Pressure Regulator Retainer . . . . .	25-30
Oil Screen Housing to Cylinder Block . . . . .	6-9
Oil Pan Baffle to Cylinder Block . . . . .	9-13
Oil Gallery Plugs . . . . .	20-30
Filter Assembly to Pump Cover . . . . .	10-15
Timing Chain Cover to Block . . . . .	17-23
Water Pump Cover to Timing Chain Cover . . . . .	6-8
Fan Driven Pulley . . . . .	17-23
Thermostat Housing to Intake Manifold . . . . .	17-23
Intake Manifold to Cylinder Head . . . . .	45-55
Exhaust Manifold to Cylinder Head . . . . .	10-15
Carburetor to Intake Manifold . . . . .	10-15
Fuel Pump to Cylinder Block . . . . .	17-23
Motor Mount to Cylinder Block . . . . .	50-75
Fuel Pump Eccentric and Timing Chain Sprocket to Camshaft . . . . .	40-55
Rocker Arm Cover to Cylinder Head . . . . .	3 to 5
Rocker Arm Shaft Bracket to Cylinder Head . . . . .	25-35
Delcotron Bracket to Cylinder Head . . . . .	30 to 40
Delcotron Bracket to Water Pump Timing Chain Cover . . . . .	18-25
Delcotron Mounting Bracket Thru Delcotron to Cylinder Head at Pivot Location . . . . .	30-40
Starting Motor to Block . . . . .	30-40
Starting Motor Brace to Block . . . . .	9-13
Starting Motor Brace to Starting Motor . . . . .	9-13
Distributor Hold-down Clamp . . . . .	10-15
Manual Lower Flywheel Housing Plate . . . . .	9-13
Flywheel Housing to Cylinder Block . . . . .	30-40
Fuel Filter to Cylinder Head . . . . .	10-15

**60-2 GENERAL SPECIFICATIONS****a. General**

	Wildcat 310 (300 Cu. In.)	Wildcat 350 (340 Cu. In.)	Wildcat 375 (340 Cu. In.)
Code Number Prefix . . . . .	ML	MA	MB
Export Code Number Prefix . . . . .	MM	MC	Not Available
Engine Type . . . . .	90° V-8	90° V-8	90° V-8
Bore and Stroke . . . . .	3.750 x 3.400	3.750 x 3.850	3.750 x 3.850
Piston Displacement . . . . .	300 Cu. In.	340 Cu. In.	340 Cu. In.
Carburetor Type . . . . .	2 Bbl.	2 Bbl.	4 Bbl.
Compression Ratio . . . . .	9.0:1	9.0:1	10.25:1
Gasoline Requirements . . . . .	Regular	Regular	Premium
Brake Horsepower @ RPM . . . . .	210/4600	220/4000	260/4000
Maximum Torque @ RPM . . . . .	310/2400	340/2400	365/2800
Taxable Horsepower . . . . .	33.748	45.0	45.0
Octane Requirement - Motor . . . . .	85	85	90
Octane Requirement - Research . . . . .	93	93	99
Cylinder Numbers - Front to Rear-Left Bank . . . . .	1-3-5-7	1-3-5-7	1-3-5-7
Cylinder Numbers - Front to Rear-Right Bank . . . . .	2-4-6-8	2-4-6-8	2-4-6-8
Firing Order . . . . .	1-8-4-3-6-5-7-2	1-8-4-3-6-5-7-2	1-8-4-3-6-5-7-2

**60-2 GENERAL SPECIFICATIONS (Cont'd.)****b. Piston and Pin Specifications**

Piston	
Material . . . . .	Cast Aluminum Alloy
Type . . . . .	Divorced Skirt
Finish . . . . .	Cam Ground
Piston Pins	
Material . . . . .	Extruded SAE-1018
Type . . . . .	Pressed In Rod

**c. Connecting Rods**

Material . . . . .	Pearlitic Malleable Iron
Rod Bearing . . . . .	Removable Steel Backed M/400

**d. Ring Specifications**

#1 Compression . . . . .	Cast Iron-Chrome Plated
#2 Compression . . . . .	Cast Iron-Lubrited
Oil Control . . . . .	Steel-Uncoated
Oil Ring Expander . . . . .	Steel Humped Ring
Ring Locations . . . . .	Above Pin

**e. Crankshaft Specifications**

Material . . . . .	Pearlitic Malleable Iron
Bearings . . . . .	5 Replaceable Steel Backed
Bearing Material . . . . .	#1, #2, #3, and #4 - M/400 #5 - M/100 Durex
Bearing Taking End Thrust . . . . .	#3

**f. Camshaft Specifications**

Material . . . . .	Cast Alloy Iron
Bearings . . . . .	Steel Backed Bobbitt
Number of Bearings . . . . .	5
Drive . . . . .	Chain
Number of Links . . . . .	54
Crankshaft Sprocket . . . . .	Sintered Iron
Camshaft Sprocket . . . . .	Nylon Coated Aluminum

**g. Valve Specifications**

Intake Valve Material . . . . .	SAE 1041 Steel
Exhaust Valve Material . . . . .	GM-N82152 (21 - 4N)
Valve Lifter Mechanism . . . . .	Hydraulic
Valve Spring . . . . .	Single Helical

**h. Lubrication System Specifications**

Type of Lubrication	
Main Bearings . . . . .	Pressure
Connecting Rods . . . . .	Pressure
Piston Pins . . . . .	Splash
Camshaft Bearing . . . . .	Pressure
Timing Chain . . . . .	Splash and Nozzle
Cylinder Walls . . . . .	Splash and Nozzle
Oil Pump Type . . . . .	Gear Driven
Normal Oil Pressure . . . . .	33 lbs. @ 2400 RPM
Oil Pressure Sending Unit . . . . .	Electrical
Oil Intake . . . . .	Stationary
Oil Filter System . . . . .	Full Flow
Filler Type . . . . .	Throw-Away Element and Can
Crankcase Capacity	
Less Filter . . . . .	4 qts.
With Filter . . . . .	5 qts.

**60-2 GENERAL SPECIFICATIONS (Cont'd.)****i. Cooling System Specifications**

System Type . . . . .	Pressure
Radiator Cap Relief Pressure . . . . .	15 psi
Thermostat . . . . .	Choke Type Opening at 180°
Water Pump	
Type . . . . .	Centrifugal
GPM @ RPM . . . . .	14 @ 100
Drive . . . . .	V-Belt
Bearings . . . . .	Double Row
By-Pass Recirculation Type . . . . .	External

**Cooling System Capacities**

	(300 Cu. In.)	(340 Cu. In.)
With Heater . . . . .	12.7 qts.	12.7 qts.
W/O Heater . . . . .	12.2 qts.	12.2 qts.
With Air Conditioning (All except 300 Cu. In. Station Wagon) . . . . .	14.0 qts.	14.7 qts.
With Air Conditioning (Station Wagon) . . . . .	14.7 qts.	14.7 qts.

**Fan Diameter and Number of Blades**

Less AC . . . . .	18" x 4
With AC . . . . .	18" x 7
Fan Drive	
Less AC . . . . .	Water Pump Shaft
With AC . . . . .	Torque and Temperature Sensitive Clutch

**60-3 ENGINE DIMENSIONS AND FITS****a. General**

Piston Clearance Limits*	
Top Land . . . . .	.0265 - .0345
Skirt - Top . . . . .	.0005 - .0011
Skirt - Bottom . . . . .	.0005 - .0021
Ring Groove Depth	
#1 - Compression Ring . . . . .	.1855 - .1930
#2 - Compression Ring . . . . .	.188 - .1955
#3 - Oil Ring . . . . .	.188 - .1955
Ring Width	
#1 - Compression Ring . . . . .	.0785 - .0789
#2 - Compression Ring . . . . .	.0770 - .0780
#3 - Oil Ring . . . . .	.1810 - .1870
Ring Gap	
#1 - Compression Ring . . . . .	.010 - .020
#2 - Compression Ring . . . . .	.010 - .020
#3 - Oil Ring . . . . .	.015 - .035
Piston Pin Length . . . . .	3.060
Diameter of Pin . . . . .	.9394 - .9397
Clearance	
In Piston . . . . .	.0001 - .0004
In Rod . . . . .	.0007 - .0015 Press
Direction & Amount Offset in Piston . . . . .	.040 Toward High Thrust Side

\*All Measurements in Inches Unless Otherwise Specified.

**b. Connecting Rod Specifications**

Bearing Length . . . . .	.737
Bearing Clearance (Limits) . . . . .	.0020 - .0023
End Play - Total for Both Rods . . . . .	.006 - .014

## 60-3 ENGINE DIMENSIONS AND FITS (Cont'd.)

## c. Crankshaft Specifications

End Play at Thrust Bearing . . . . .	.004 - .008
Main Bearing Journal Diameter . . . . .	2.9995
Crankpin Journal Diameter . . . . .	2.0000
Main Bearing Overall Length	
#1 . . . . .	.864
#2 . . . . .	.864
#3 . . . . .	1.057
#4 . . . . .	.864
#5 . . . . .	.864
Main Bearing to Journal Clearance . . . . .	.0004 - .0015

## d. Camshaft Specifications

Bearing Journal Diameter	
#1 . . . . .	1.785 - 1.786
#2 . . . . .	1.755 - 1.756
#3 . . . . .	1.725 - 1.726
#4 . . . . .	1.695 - 1.696
#5 . . . . .	1.665 - 1.666
Journal Clearance in Bearings . . . . .	.005 - .0025 (#1) .005 - .0035 (#2, #3, #4, & #5)

## e. Valve System Specifications

Rocker Arm Ratio . . . . .	1.6 to 1
Rocker Arm Clearance on Shaft . . . . .	.0017 - .0032
Valve Lifter Diameter . . . . .	.8422 - .8427
Valve Lifter Clearance in Crankcase . . . . .	.0015 - .003
Valve Lifter Leakdown Rate . . . . .	12 to 60 Sec. in Test Fixture
Intake Valve	
Head Diameter . . . . .	1.8175 - 1.8075
Seat Angle . . . . .	45°
Stem Diameter . . . . .	(Top) .3415 - .3412 (Bottom) .3405
Clearance in Guide . . . . .	.0012 - .0032 & .0003 Max. Taper
Valve Spring	
Valve Closed - Pounds @ Length . . . . .	64 ± 5 @ 1.727
Valve Open - Pounds @ Length . . . . .	164 ± 6 @ 1.340
Exhaust Valve	
Head Diameter . . . . .	1.380 - 1.370
Seat Angle . . . . .	45°
Stem Diameter . . . . .	(Top) .3402 - .3412 (Bottom) .3397 - .3407
Clearance in Guide . . . . .	(Top) .0015 - .0035 (Bottom) .0021 - .004
Valve Spring	
Valve Closed - Pounds @ Length . . . . .	64 ± 5 @ 1.727
Valve Open - Pounds @ Length . . . . .	164 ± 6 @ 1.340

## 60-4 ENGINE TUNE-UP AND ADJUSTMENTS

## a. Purpose of Tune-Up

The purpose of an engine tune-up is to restore power and performance that has been lost through wear, corrosion or deterioration of one or more parts or units. In the normal operation of an engine, these changes take place gradually at a number of points so that it is seldom advisable to attempt an improvement in performance by correction of one or

two items only. Time will be saved and more lasting results will be obtained by following a definite and thorough procedure of analysis and correction of all items affecting power and performance.

Economical, trouble-free operation can better be assured if a complete tune-up is performed each 12,000 miles.

The parts or units which affect power and performance may be divided into three groups:

- (1) Units affecting compression
- (2) Units affecting ignition, and
- (3) Units affecting carburetion.

The tune-up procedure should cover these groups in the order given. While the items affecting compression and ignition may be handled according to personal preference, correction of items in the carburetion group should not be attempted until all items affecting compression and ignition have been satisfactorily corrected.

Most of the procedures for performing a complete engine tune-up are covered separately in other sections of this manual; therefore, this paragraph provides an outline only, with references to other sections where detailed information is given.

The suggested procedure for engine tune-up is as follows:

1. Remove all spark plugs.
2. Position throttle and choke valve in full open position.
3. Connect jumper wire between distributor terminal of coil and ground on engine to avoid high tension sparking while cranking engine.
4. Hook up starter remote control cable and turn ignition switch to "on" position.

**CAUTION:** The starter must not be energized when the ignition switch is in the LOCK position as the ground contact will be damaged in the ignition switch.

5. Firmly insert compression gauge in spark plug port. Crank engine through at least four compression strokes to obtain highest possible reading.
6. Check compression of each cylinder. Repeat compression check and record highest reading obtained on each cylinder during the two pressure checks.

The recorded compression pressures are to be considered normal if the lowest reading cylinder is more than 75% of the highest reading cylinder. See the following example and the "Compression Pressure Limit Chart".

75% of 140 (highest) is 105. Thus, cylinder number 6 is less than 75% of number 3. This condition, accompanied by low speed missing, indicates an improperly seated valve or worn or broken piston ring.

Example:

Cylinder #	Pressure (PSI)
1	129
2	135
3	140
4	121
5	120
6	100
7	130
8	126

7. If one or more cylinders read low, inject about a tablespoon of engine oil on top of pistons in low reading cylinders through spark plug port. Repeat compression check on these cylinders.

a. If compression improves considerably, rings are worn.

b. If compression does not improve, valve are sticking or seating poorly.

c. If two adjacent cylinders indicate low compression and injection oil does not increase compression, the cause may be a head gasket leak between the cylinders. Engine coolant and/or oil in cylinders could result from this defect.

**NOTE:** Low compression pressure in two adjacent cylinders indicates a possible head gasket leak between the two cylinders.

8. Clean, inspect, gap to .035", and install spark plugs.

9. Inspect battery and cables.

10. If battery is in good condition but cranking speed is low, test cranking motor circuit.

11. Adjust fan belt (and power steering belt if so equipped). If difficulty is experienced in keeping battery charged, check generator regulator.

12. Inspect entire ignition system and make indicated corrections.

13. Inspect and test fuel pump.

14. Clean gasoline filter.

15. Check operation of choke

valve and check setting of choke thermostat.

16. Check adjustment of fast idle cam and choke unloader.

17. Check throttle linkage and dash pot adjustment.

18. Adjust carburetor idle speed and mixture.

19. Inspect all water hose connections and tighten clamps if necessary.

20. Road test car for power and overall performance.

**b. Compression Pressure Limit Chart**

This chart may be used when checking cylinder compression pressures. It has been calculated so that lowest reading number is 75% of the highest reading number.

Example: After checking the compression pressures in all cylinders, it was found that the highest pressure obtained was 182 psi. The lowest pressure reading was 145 psi. By locating 182 in the maximum column, it is seen that the maximum allowable pressure is 136 psi. Since the lowest reading obtained was 145 psi, the car is within limits and the compression is considered satisfactory.

Maximum Pressure Pounds/ Sq. Inch	Minimum Pressure Pounds/ Sq. Inch
134	101
136	102
138	104
140	105
142	107
144	108
146	110
148	111
150	113
152	114
154	115
156	117
158	118

Maximum Pressure Pounds/ Sq. Inch	Minimum Pressure Pounds/ Sq. Inch	Maximum Pressure Pounds/ Sq. Inch	Minimum Pressure Pounds/ Sq. Inch	Maximum Pressure Pounds/ Sq. Inch	Minimum Pressure Pounds/ Sq. Inch
160	120	186	140	212	158
162	121	188	141	214	160
164	123	190	142	216	162
166	124	192	144	218	163
168	126	194	145	220	165
170	127	196	147	222	166
172	129	198	148	224	168
174	131	200	150	226	169
176	132	202	151	228	171
178	133	204	153	230	172
180	135	206	154	232	174
182	136	208	156	234	175
184	138	210	157	236	177
				238	178

**c. Tune-up Specification**

Checks	Sun Tune-Up Tester	
1. Secondary Resistance . . . . .	3 + .5 @ 1500 RPM	
2. Ignition Output . . . . .	Blue Band @ 1500 RPM	
3. Cranking Voltage . . . . .	9 Volts Min.	
4. Charging Voltage* (Quick Check-Cold) . . . . .	14-15 Volts @ 1500 RPM	
5. Spark Plug Gap . . . . .	.035 Inches	
6. Dwell Angle . . . . .	30 Degrees	
7. Engine Vacuum . . . . .	14 Inches Min. @ Idle	
8. Engine Idle Speed (Manual in Neutral or Automatic in Drive-Air Conditioner Off) . . . . .	550 RPM (Add 50 RPM for Air Conditioner and/or Air Induction Reactor)	
9. Initial Timing (At Engine Idle, Vacuum Hose Disconnected) . . . . .	300 (Cu. In.) Eng. 2 1/2°	340 (Cu. In.) Eng. 2 1/2°
10. Total Distributor Advance** . . . . . (@ 2500 Engine RPM)	31° -39°	28° -36°
11. Centrifugal Advance Only** . . . . .	17° -21°	14° -18°

\*Regular at Room Temperature (Below 85° F.)

\*\*This Advance in Addition to Initial Timing Advance

**DIVISION II DESCRIPTION AND OPERATION**

**60-5 ENGINE CONSTRUCTION**

**a. Engine Usage**

Series	Engine Code No. Prefix	Cubic In. Displacement	Use	Compression Ratio	Carburetor
43400	ML	300	Standard	9.0 :1	2 Bbl.
43600	MB	340	Optional	10.25:1	4 Bbl.
44400	MM	300	Export	7.6 :1	2 Bbl.
(Except 55 & 56)	MC	340	(Optional Export)	7.6 :1	2 Bbl.
44255					
44265	MA	340	Standard	9.0 :1	2 Bbl.
44455	MB	340	Optional	10.25:1	4 Bbl.
44465	MC	340	Export	7.6 :1	2 Bbl.
45000					

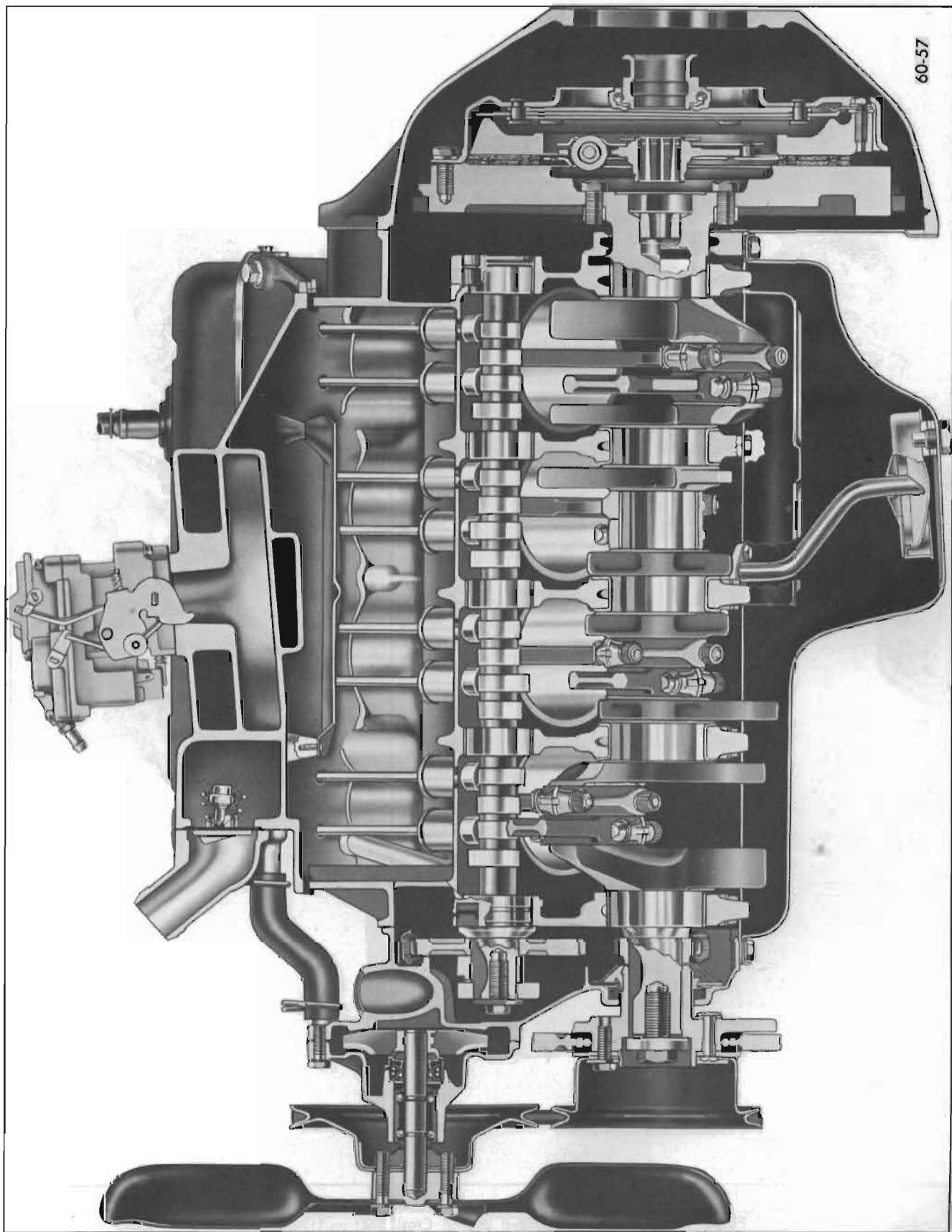
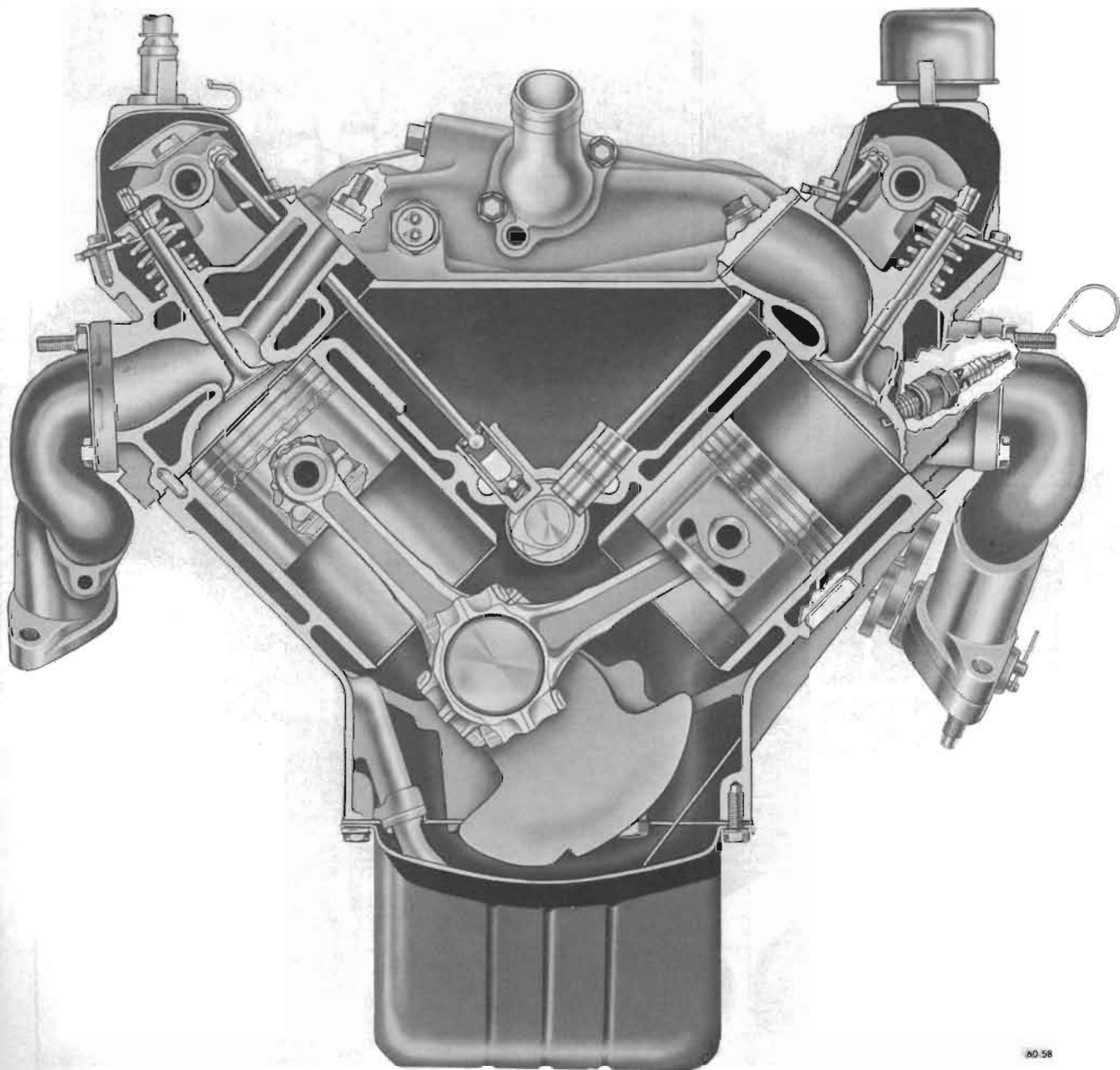

Figure 60-57—300 Cu. In. V-8 Engine Cross Section (Side View)





60-58

Figure 60-58—300 Cu. In. V-8 Engine Cross Section (Front View)

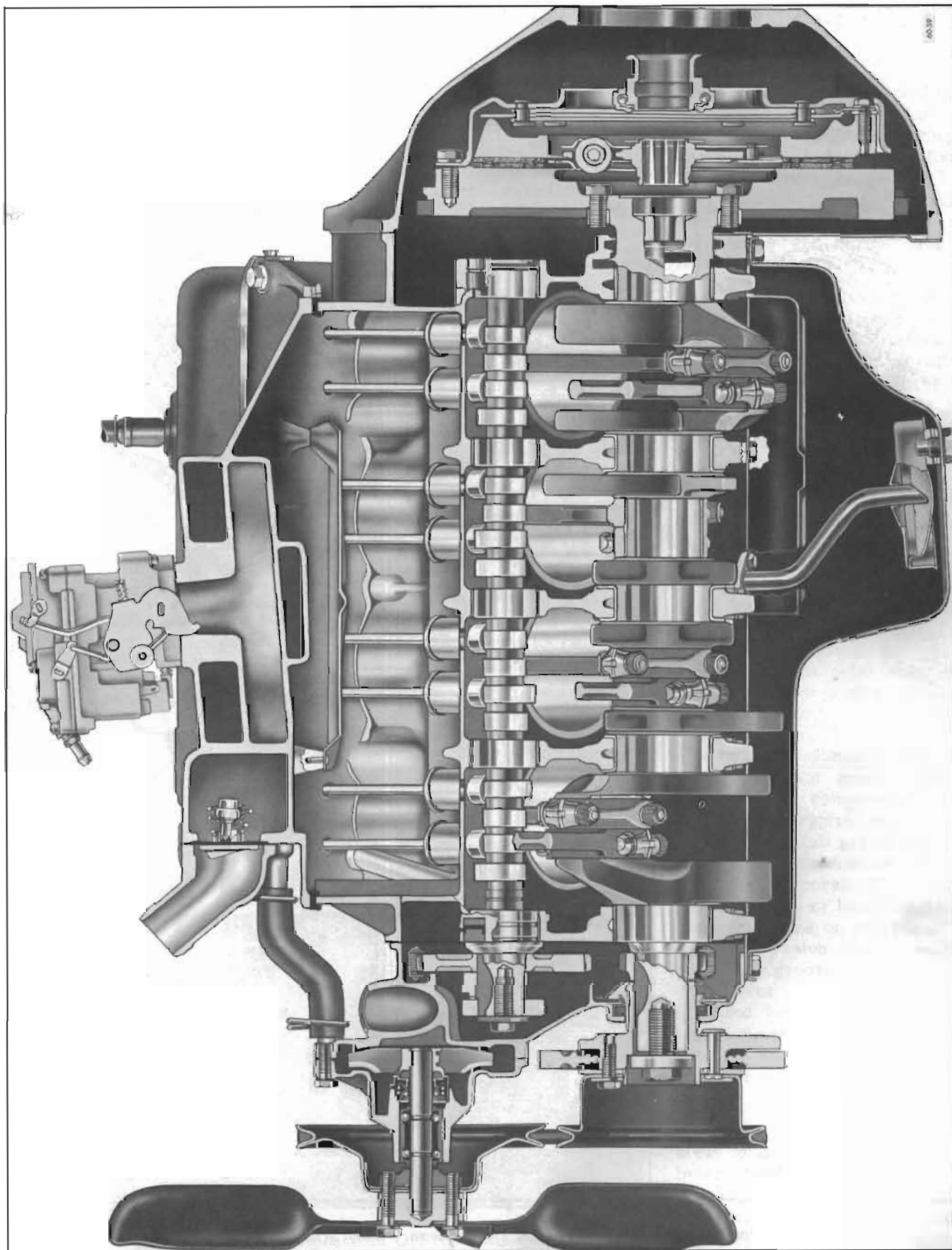
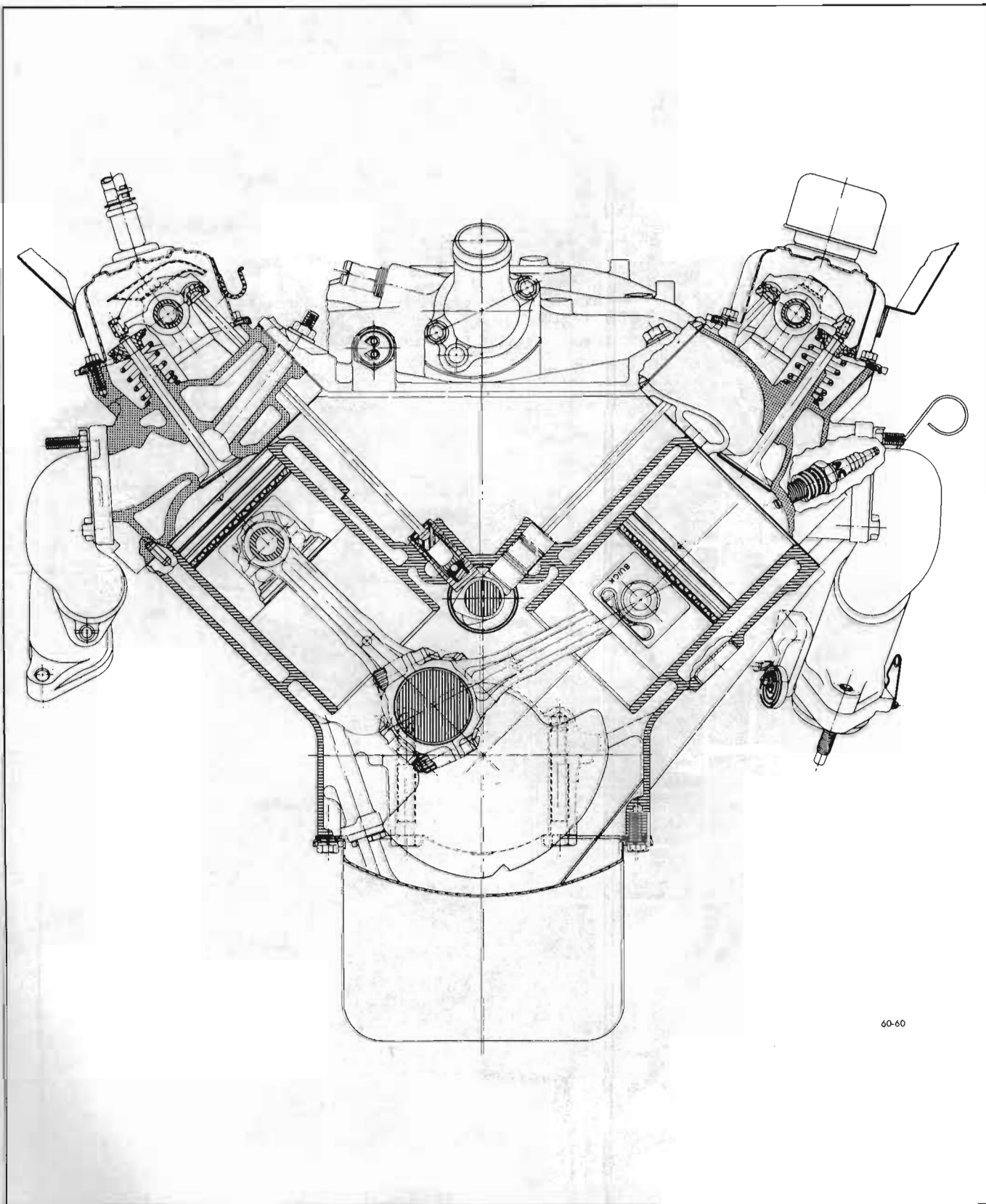

Figure 60-59--340 Cu. In. V-8 Engine Cross Section (Side View)



60-60

Figure 60-60-340 Cu. In. V-8 Engine Cross Section (Front View)

The same basic 300 and 340 cubic inch V-8 engine is used with either manual or automatic transmission. The manual model is equipped with a cast iron flywheel and flywheel housing. Automatic transmission engines are equipped with a stamped steel flywheel that bolts to the transmission converter pump. V-8 engines equipped with two barrel carburetors have a compression ratio of 9.0 to 1 which permits the use of "regular grade" gasoline. Engines equipped with 4 barrel carburetors have a compression ratio of 10.25 to 1 which requires the use of "premium" or "high test" gasoline.

#### b. Engine Mounting

The engine-transmission unit is mounted to the chassis at three points by synthetic rubber pads.

The two front mounts are bolted to the engine crankcase and the frame cross member. These

mounts support most of the engine weight and control its torsional characteristics. The single rear mount is placed between the transmission and the transmission support and is secured by two bolts. It supports part of the engine and transmission weight and locates the rear of the engine with respect to the centerline of the car.

#### c. Engine Construction

The engine crankcase is made of cast iron. Two banks of cylinders - four cylinders per bank - are cast at a 90° angle. The lower part of the crankcase extends below the centerline of the crankshaft, forming a continuous flat surface with the rear bearing cap and the timing chain cover. This design allows installation of an oil sump pan with a one-piece gasket. The cylinders in the left bank (as viewed from the drivers seat) are numbered 1-3-5-7, counting from front to rear. The cylinders in the right bank are

numbered 2-4-6-8, counting from front to rear.

The crankshaft is supported in the crankcase by steel-backed full precision bearings, all having the same nominal diameter. Except for the thrust bearing and the rear main bearing, all bearings are identical. The thrust bearing (#3) takes end thrust and has flanges for that purpose.

The crankshaft is counterbalanced by weights cast integral with the crank cheeks. Maximum counterweighting in the space available is accomplished by precision casting the counterweights to a contour which allows a minimum uniform clearance with cylinder barrels and piston skirts.

Connecting rods are of I-beam section with bosses on each side so metal can be removed as required to obtain correct weight and balance. The lower end of each rod is fitted with a steel-backed full precision bearing. The piston pin is a press fit into the upper end. The outer ends of the piston pin are a slide fit in the piston bosses.

The full skirt aluminum alloy pistons are cam ground and tin plated. Two compression rings and one oil control ring are located above the piston pin. The cast iron compression rings in the upper groove of the piston have a groove or bevel cut around the inner edge on one side. The top compression ring is installed with this groove or bevel down. The lower compression ring is installed bevel up. The oil ring in the lower groove consists of two thin steel rails separated by a spacer expander.

The cylinder heads are cast iron and incorporate cast in valve stem guides. Right and left cylinder heads are identical and interchangeable, although in service, it is good practice to replace the cylinder heads on the

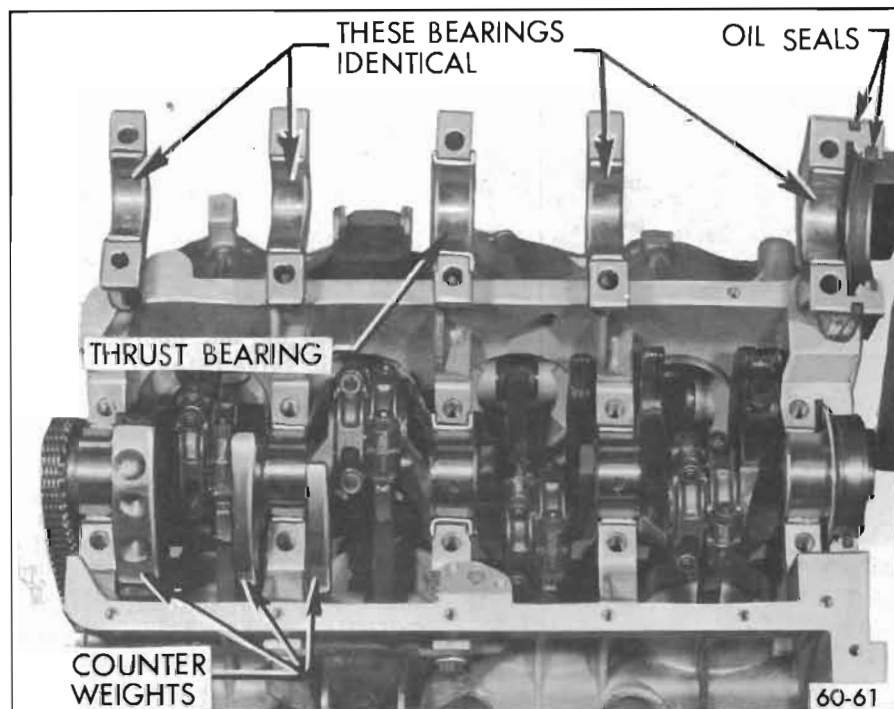

Figure 60-61—Lower Engine With Oil Pan Removed



Figure 60-62—Piston and Connecting Rod side from which they were removed.

The valves are in line in each head and operate at an angle  $10^{\circ}$  above the centerline of the cylinder bores. The spark plug in each cylinder is located so that the point gap is ideally located with respect to the sweep of the incoming charge. Each valve has a spring of ample capacity to insure positive valve seating throughout the operating speed range of the engine. The intake valve heads are 1.625" in diameter while the exhaust valve heads are 1.375" in diameter.

The valve rocker arm mechanism is covered by a sheet metal cover which seats against a raised surface of the cylinder head and is gasketed to prevent oil leaks. The rocker arms for each bank of cylinders are mounted on a tubular steel shaft supported on the cylinder head by die cast brackets.

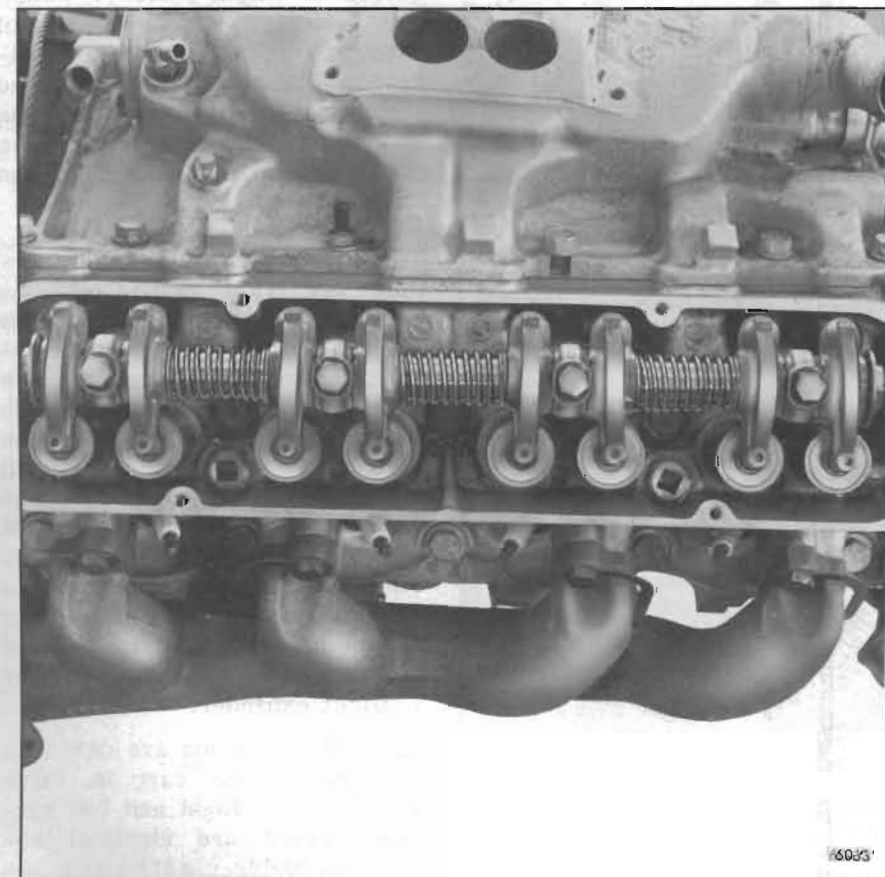

Figure 60-63—Engine Valve Mechanism

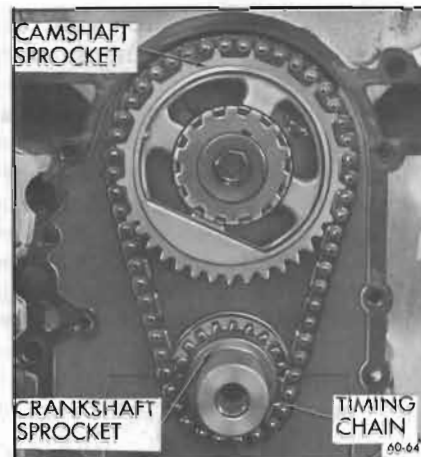

Figure 60-64—Timing Chain Installation

Rocker arms are die cast aluminum with inserts at the push rod socket and the valve stem contact face.

The camshaft is located above the crankshaft between the two banks of cylinders. It is supported in five steel-backed babbit bearings and driven at half crankshaft speed by sprockets and a single outside guide type chain.

Hydraulic valve lifters and one piece push rods are used to operate the overhead rocker arms and valves on both banks of cylinders using a single camshaft. This system requires no lash adjustment at time of assembly or in service. Construction of the hydraulic valve lifter can be seen in Figure 60-65. Refer to paragraph 60-6 in the V-6 engine section of the 1966 Special Chassis Service Manual for a detailed description of the operation of a hydraulic valve lifter.

## 60-6 LUBRICATION SYSTEM

The engine lubrication system is the force feed type in which oil is supplied under pressure to the shaft bearings and valve lifters. Oil is supplied under controlled volume to the rocker arm bearings and push rods. All other moving parts are lubricated by gravity flow or splash.



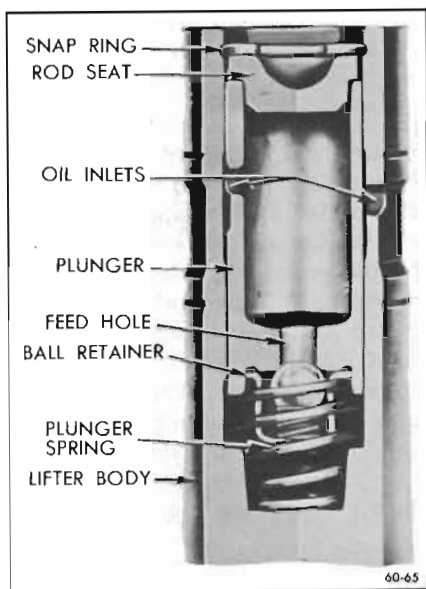

Figure 60-65—Hydraulic Lifter  
Cross Section

The supply of oil is carried in the lower crankcase (oil pan) which is filled through a filler opening in the left rocker arm cover. The filler opening is covered by a combination filler and ventilating cap which contains a metal gauze to exclude dust. A removable oil gauge rod on the left side of the crankcase is provided to check oil level.

The oil pump is located in the timing chain cover where it is connected by a drilled passage in the cylinder crankcase to an oil screen housing and pipe assembly. The screen is submerged in the oil supply and has ample area for all operating conditions. If the screen should become clogged for any reason, oil may be drawn into the system over the top edge of the screen which is held clear of the sheet metal screen housing.

Oil is drawn into the pump through the screen and pipe assembly and a drilled passage in the crankcase which connects to drilled passages in the timing chain cover. All oil is discharged from the pump to the oil pump

cover assembly. The cover assembly consists of an oil pressure relief valve, an oil filter by-pass valve and a nipple for installation of an oil filter. The spring loaded oil pressure relief valve limits the oil pressure to a maximum of 30 pounds per square inch. The oil filter by-pass valve opens when the filter has become clogged to the extent that 4-1/2 to 5 pounds pressure difference exists between the filter inlet and exhaust to by-pass the oil filter and channel unfiltered oil directly to the main oil galleries of the engine.

An AC full flow oil filter is externally mounted to the oil filter cover nipple on the right side of the engine just below the generator. Normally, all engine oil passes through the filter element, however, if the element becomes restricted, a spring loaded by-pass valve opens as mentioned above.

The main oil galleries run the full length of the crankcase and cut into the valve lifter guide holes to supply oil at full pressure to the lifters. Connecting passages drilled in the crankcase permit delivery of oil at full pressure to all crankshaft and camshaft bearings.

Holes drilled in the crankshaft carry oil from the crankshaft bearings to the connecting rod bearings. Pistons and cylinder walls are lubricated by oil forced through a small notch in the bearing parting surface on the connecting rod, which registers with the hole in the crankpin once in every revolution. Piston pins are lubricated by splash.

Drilled holes in the camshaft connect the front camshaft bearing journal to the keyslot in the front of the camshaft. Oil flows from the journal into the keyslot over the woodruff key in the space between the key and the camshaft sprocket and fuel pump eccentric.

The forward end of the fuel pump eccentric incorporates a relief which allows the oil to escape between the fuel pump eccentric and the camshaft distributor gear. The oil stream strikes the distributor shaft gear once each camshaft revolution and provides ample lubrication of the timing chain and sprockets by splash.

The rocker arms and valves on each cylinder head are supplied with oil from the oil galleries through holes drilled in the front of the cylinder block and cylinder head. The hole drilled in the cylinder head ends beneath the front rocker arm shaft bracket. A notch cast in the base of the rocker arm shaft bracket allows the oil to flow up inside the bracket in the space between the bracket and bolt to the hollow rocker arm shaft which is plugged at both ends. Each rocker arm receives oil through a hole in the under side of the shaft.

Grooves in the rocker arm provide lubrication of the bearing surface. Oil is metered to the push rod seat and valve stem through holes drilled in the rocker arm. Excess oil drains off and returns to the oil pan

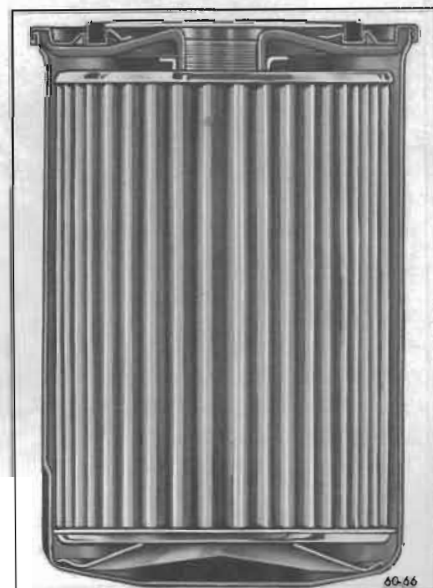

Figure 60-66—Oil Filter Cross Section

through passages in the cylinder head and block.

### 60-7 COOLING SYSTEM

The engine cooling system is the pressure type with thermostatic control of coolant circulation.

The cooling system is sealed by a pressure type radiator filler cap which causes the system to operate at higher than atmospheric pressure. The higher pressure raises the boiling point of the coolant and increases the cooling efficiency of the radiator. The 15

pound pressure cap used raises the coolant boiling point approximately 38°F.

The pressure type radiator filler cap contains a blow off or pressure valve and a vacuum or atmospheric valve. The pressure valve is held against its seat by a spring of predetermined strength which protects the radiator by relieving the pressure if the pressure should exceed that for which the radiator is designed.

The vacuum valve is held against its seat by a light spring which

permits opening of the valve to relieve vacuum created when the system cools off.

The coolant is circulated by a centrifugal pump mounted on the timing chain cover which forms the outlet side of the pump. The engine fan and pulley(s) are bolted to the pump shaft hub at its forward end. Thus both the fan and pump are belt driven by a crankshaft pulley bolted to the harmonic balancer. The pump shaft and bearing assembly is pressed in the aluminum water pump cover. The bearings are permanently lubricated during manufacture

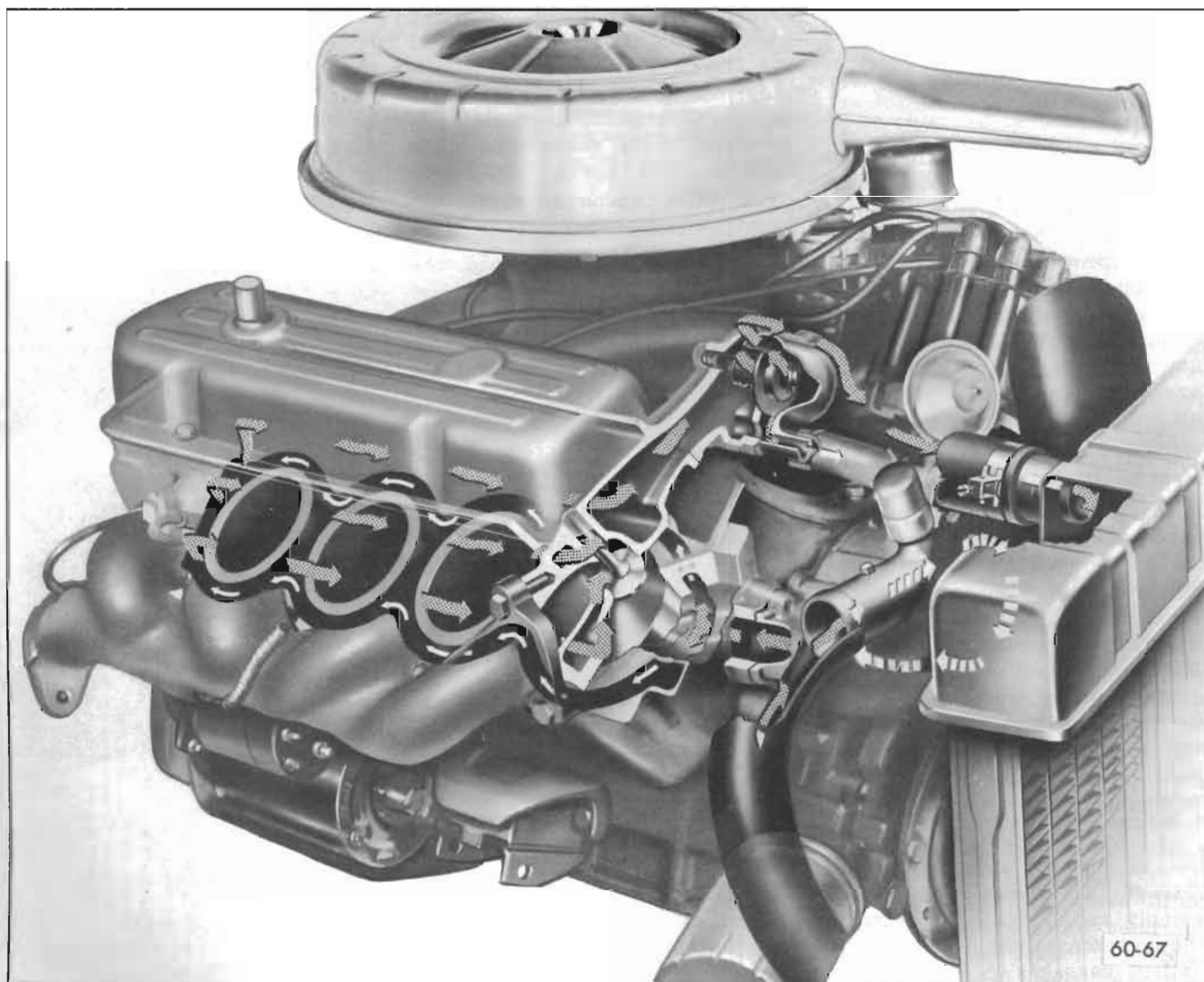

Figure 60-67—V-8 Engine Coolant Flow

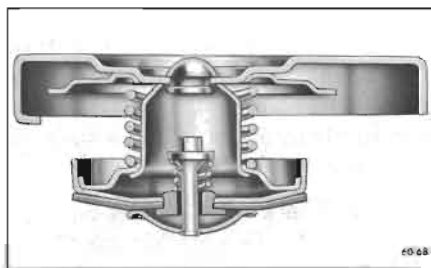

Figure 60-68—Radiator Pressure Cap  
Cross Section

and sealed to prevent loss of lubricant and entry of dirt. The pump is sealed against coolant leakage by a packless non-adjustable seal assembly mounted on the pump cover in position to bear against the impeller hub. The inlet pipe cast in the pump cover feeds into the passage formed by the cover and the front face of the impeller, which is mounted on the bearing shaft with the vanes facing rearward. Coolant flows through the inlet passage to the low pressure area at the center where it then flows rearward through three openings in the impeller. Vanes on the rotating impeller cause the coolant to flow radially outward through two discharge passages cast in the timing chain cover. These passages deliver an equal quantity of coolant to each cylinder bank water jacket.

The coolant then flows rearward through the water jacket which surrounds each cylinder barrel and extends below the lower limit of piston ring travel. After flowing the full length of the cylinder banks, the coolant flows up through openings to the rear of the cylinder bank into the cylinder heads. The coolant flows forward in the cylinder heads to cool the combustion chamber areas. At the forward end of the cylinder heads the coolant flows into the thermostat housing and thermostat by-pass.

A pellet type thermostat housed in the forward (outlet) end of the

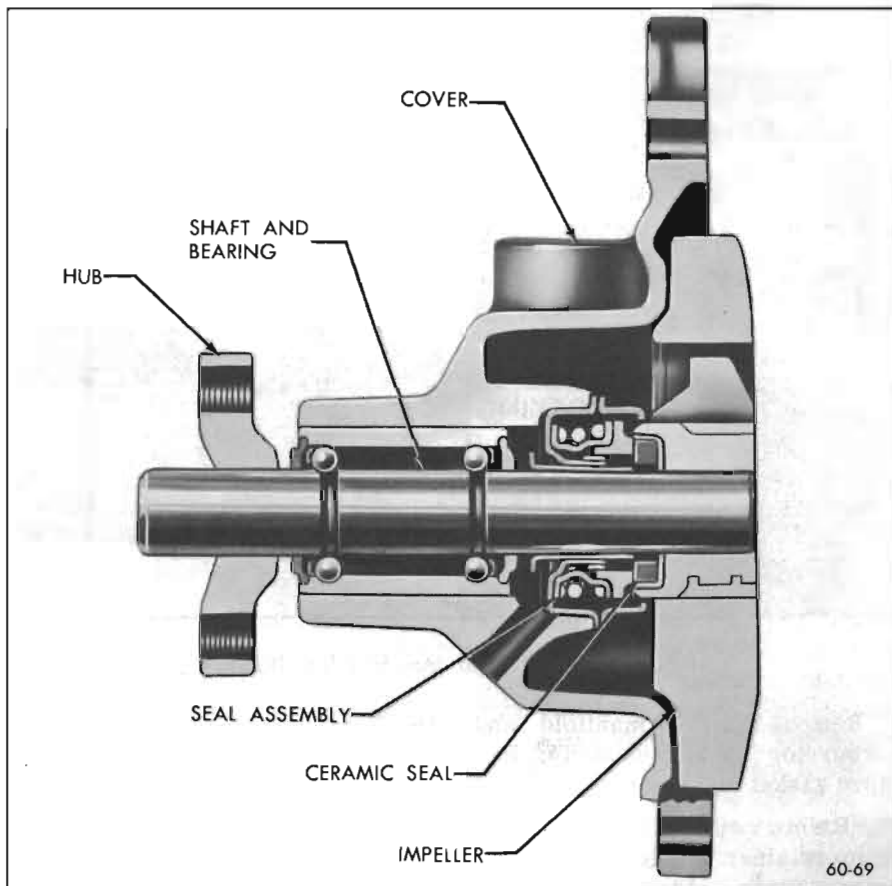

Figure 60-69—Water Pump Cross Section

intake manifold controls the circulation of water through the engine radiator. During cold engine operation when the thermostat is closed, a thermostat by-pass, open at all times, allows recirculation of coolant through the engine to provide rapid warm-up. When the thermostat opens, coolant is directed to the upper tank of the radiator and thence through the radiator core, lower tank to water pump inlet where the cycle is repeated.

### DIVISION III SERVICE PROCEDURES

#### 61-1 CYLINDER HEADS, VALVES, AND LIFTERS

##### a. Cylinder Head Removal

1. Drain radiator and cylinder block.

2. Remove air cleaner. Disconnect all pipes and hoses from carburetor.

3. Remove coil. Disconnect water temperature indicator wire from switch.

4. Disconnect throttle linkage at carburetor.

5. Disconnect positive crankcase ventilator hose at valve.

6. Slide front thermostat by-pass hose clamp back on hose. Disconnect by-pass hose at timing chain cover to allow coolant to drain from manifold. Disconnect upper radiator hose at outlet.

7. Disconnect heater hose at intake manifold.

8. Remove bolts attaching manifold to cylinder heads.



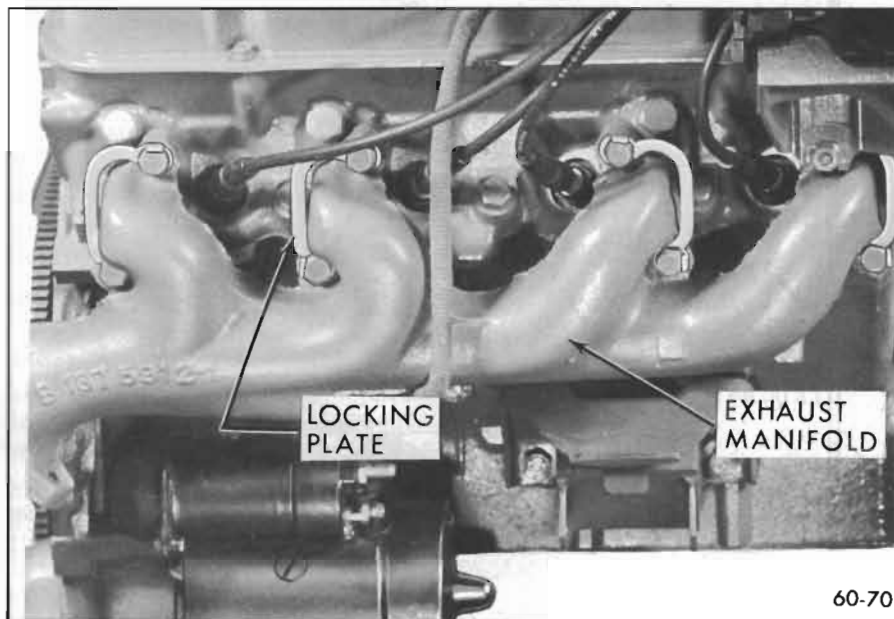

Figure 60-70—Exhaust Manifold Installation

9. Remove intake manifold and carburetor as an assembly. Remove gasket and seals.

10. Remove spark plug wires from retainer brackets on rocker arm covers. Disconnect spark plug wires at plugs and swing them out of way.

11. Remove four screws attaching rocker arm cover to cylinder head.

12. Remove rocker arm shaft bracket to cylinder head attaching bolts. Remove rocker arm and shaft.

13. Remove push rods.

**NOTE:** If lifters are to be serviced, remove them at this point. Otherwise, protect lifters and camshaft from dirt by covering area with a clean cloth.

14. Disconnect battery cable and remove Delcotron generator mounting bracket and brace attaching bolts.

15. Remove power steering pump rear bracket to cylinder head attaching bolts. Loosen bracket at pump.

16. Remove exhaust manifold to exhaust pipe bolts.

17. Remove cylinder head bolts.

18. Remove cylinder head with exhaust manifold attached. If work is to be performed on head, remove manifold on bench.

#### b. Cylinder Head Installation

1. Wipe off engine block gasket

surface and be certain no foreign material has fallen in the cylinder bores, bolt holes, or in the valve lifter area. It is good practice to clean out bolt holes with an air hose.

2. Install new head gasket on cylinder block. Dowels in the block will hold the gasket in position. Always handle gaskets carefully to avoid kinking or damage to the surface treatment of the gasket. Do not use any type of sealing material on head gaskets. The gaskets are coated with a special lacquer to provide a good seal, once the parts have warmed up.

3. Assemble exhaust manifold to cylinder head with bolts and locking plates as shown in Figure 60-70. Torque bolts to 10-15 lb. ft.

**NOTE:** Automatic transmission filler tube bracket fastens to rear bolt, right side.

4. Clean gasket surface of cylinder head and carefully set in place on the engine block dowel pins.

5. Clean and lubricate the head bolts with "Perfect Seal" sealing compound. Install bolts as shown in Figure 60-71.

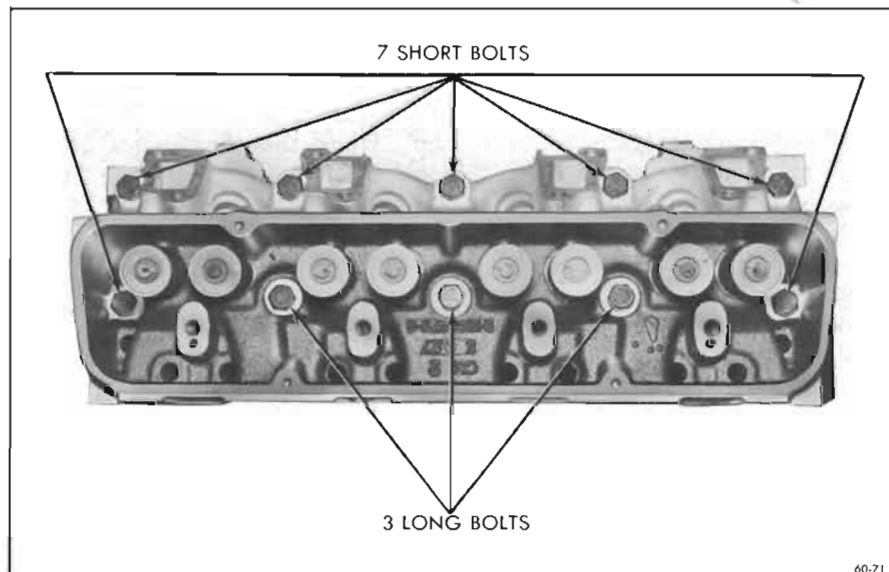

Figure 60-71—Cylinder Head Bolt Installation

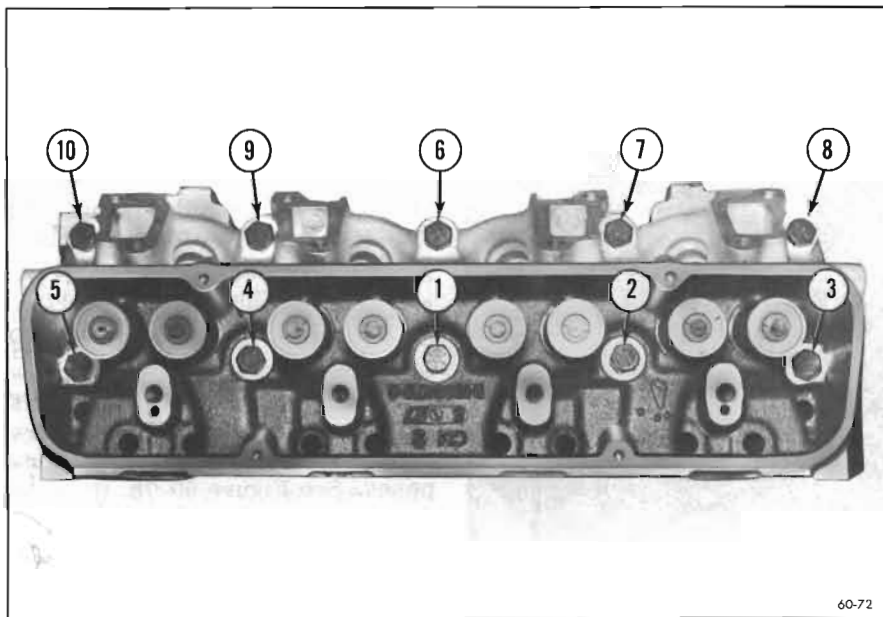

Figure 60-72—Cylinder Head Bolt Tightening Sequence

6. Tighten the head bolts a little at a time about three times around in the sequence shown in Figure 60-72. Give bolts a final torque in the same sequence. Torque to 65-80 lb. ft.

**NOTE:** Damage to the cylinder block threads can result if bolts are not lubricated with "Perfect Seal" prior to installation or if bolts are tightened excessively. Use an accurate torque wrench when installing head bolts. Uneven tightening of the cylinder head bolts can distort the cylinder bores, causing compression loss and excessive oil consumption.

7. Install push rods through cylinder head openings so rods are correctly positioned on lifter plungers.

8. Wipe bases of rocker arm shaft brackets and bosses on cylinder head with a clean cloth.

9. Check notch on one end of rocker arm shaft. Be sure it is positioned as shown in Figure 60-73.

10. Tilt the rocker arm toward the push rods and locate the top of each push rod in its rocker arm seat.

11. Draw down the rocker arm and shaft assembly by tightening the bracket bolts a little at a time. Use a reliable torque

wrench to torque the bracket bolts to 25-35 lb. ft. Do not overtighten.

12. Install rocker arm cover and gasket.

13. Connect spark plug wires and place in position on brackets on rocker arm cover.

14. Place new rubber manifold seal in position at front and rear rails of cylinder block. Be sure pointed ends of seal fit snugly against block and head. See Figure 60-74.

15. Set intake manifold in place and start two guide bolts on each side.

16. Lift the manifold slightly and slip the gaskets into position as shown in Figure 60-75. Take care to see that the gasket is installed with the intake ports aligned with the head and manifold. The gasket should be installed as shown in Figure 60-75 on the left side and reversed for the right side installation.

17. Install manifold attaching bolt in open bolt hole as shown in Figure 60-76. Open bolt hole is held to close tolerances and the bolt in

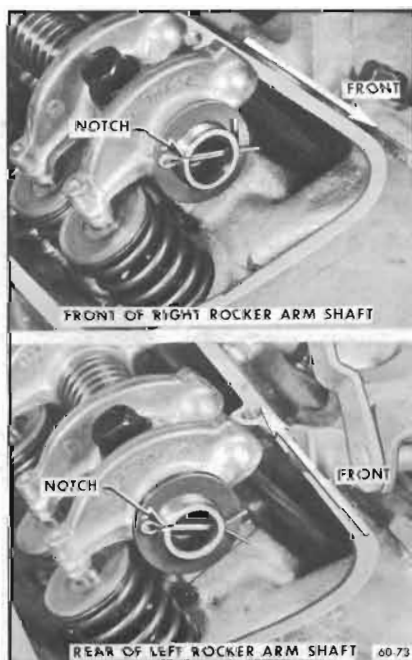

Figure 60-73—Rocker Arm Shaft Alignment



Figure 60-74—Installation of Intake Manifold Gasket Seal

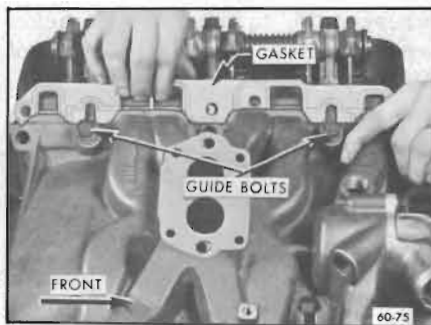

Figure 60-75—Installing Intake Manifold Gasket

this location serves to locate the manifold fore and aft.

18. Install remaining manifold to cylinder head bolts. Longer bolts belong at forward location. Torque bolts alternately and evenly to 45-55 lb. ft. See Figure 60-76.

19. Reconnect remaining components. See paragraph 60-1 for torque specifications.

### c. Reconditioning Valves and Guides

1. Remove cylinder head per subparagraph a above. Place on clean smooth surface.

2. Using suitable spring compressor, such as J-8062, compress valve spring and remove cap retainers. Release tool and remove spring and cap. See Figure 60-77.

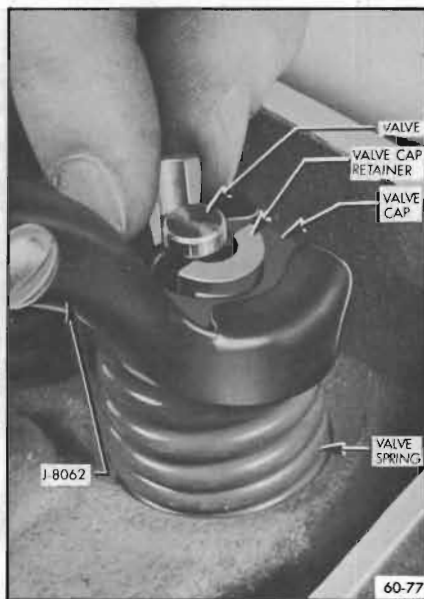

Figure 60-77—Removing Valve Cap Retainers

3. Remove valve seals from intake valves. Seals must be discarded. Remove valves. Place valves in numerical order so that they can be reinstalled in original location.

4. Remove carbon from combustion chamber of heads, using care to avoid scratching the head or the valve seats. A soft wire brush (such as J-8358) is suitable for this purpose.

5. Clean carbon and gum deposits from valve guide bores. Use Reamer J-8814.

6. Clean valves. Inspect valve faces and seats for pits, burned

spots or other evidence of poor seating.

7. Grind or replace valves as necessary. If a valve head must be ground to a knife edge to obtain a true face, the valve should be replaced; as a sharp edge will run too hot. 45° is the correct angle for valve faces.

8. If valve stem has too much clearance in its guide, the guide should be reamed to .004" oversize using J-5830-1. The Parts Department stocks .004" oversize valves for replacement purposes. See Figure 60-78.

9. True up valve seats to 45°. Cutting a valve seat results in lowering the valve spring pressure and increases the width of the seat. The nominal width of the valve seat is 1/16". If a valve seat is over 5/64" wide after truing up it should be narrowed to specified width by the use of 20° to 70° stones.

Improper hydraulic valve lifter operation may result if valve and seat are refinished to the extent that the valve stem is raised more than .050" above normal height. In this case it will be necessary to grind off the end of the valve stem or replace parts.

The normal height of the valve stem above the valve spring seat

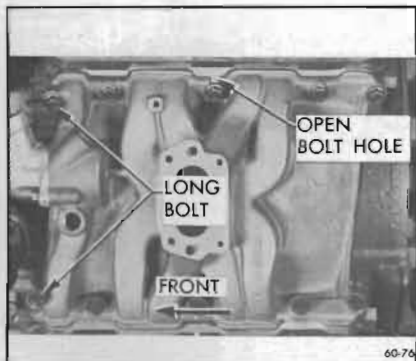

Figure 60-76—Installation of Intake Manifold

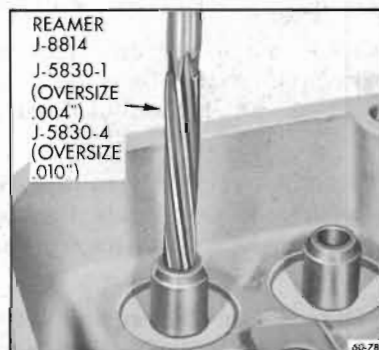

Figure 60-78—Reaming Valve Guide

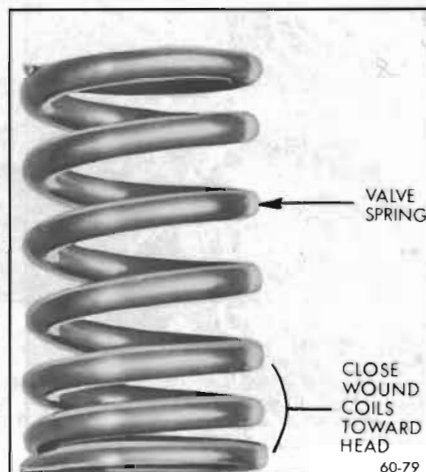

Figure 60-79—Valve Spring

surface of the head is 1.925".

10. Lightly lap the valves into seats with fine grinding compound. The refacing and reseating operations should leave the re-finished surfaces smooth and true so that a minimum of lapping is required. Excessive lapping will groove the valve face preventing a good seat when hot.

11. Test valves for concentricity with seats and for tight seating. The usual test is to coat the valve face lightly with Prussian blue and turn the valve against seat. If the valve seat is concentric with the valve guide a mark will be made all around the seat, while if the seat is not concentric with the guide, a mark will be made on only one side of the seat. Next, coat the valve seat lightly with Prussian blue. Rotate the valve against the seat to determine if the valve face is concentric with the valve stem, and if the valve is seating all the way around. Both of these tests are

necessary to prove that a proper seat is being obtained.

12. Lubricate with "Service MS" engine oil and reinstall valves.

13. Install valve seal.

a. A valve seal installation cap is provided to protect the valve seal inserts from the sharp edges of the valve stem. Place the cap on the end of valve stem and lubricate cap. If the cap extends more than 1/16" below the lower groove on the valve stem, remove cap and cut off the excess length.

b. Start valve seal carefully on cap. Hold thumbs against the white seal insert to avoid dislodging insert and push seal down slowly until jacket of valve seal contacts top of valve guide.

c. Now pull valve seal down on guide as far as it will go by pulling down on the retaining ring with two small screwdrivers, each spaced approximately 90° from gap in the ring.

14. Remove installation cap and reinstall valve springs, cap and cap retainer, using same equipment used for removal. Install valve spring with closely wound coil toward the cylinder head.

#### d. Valve Lifter Service

1. Refer to procedure outlined under "Cylinder Head Removal" (par. 61-1, subpar. a, Steps 1-13) for lifter removal.

2. Place lifter in a wooden block with numbered holes or similar device to keep them identified as to position in engine.

3. If less than a complete set of lifters is being removed, disassemble one or two and check for dirt or varnish. If this condition exists, it is advisable to remove all lifters for cleaning and inspection. Otherwise, service only those lifters that are not operating properly.

4. Examine the cam contact surface at lower end of lifter body. If this surface is extremely worn, galled, or otherwise damaged, discard the lifter assembly. In this case, examine the mating camshaft lobe for excessive wear or damage.

5. Disassemble each valve lifter by using a push rod to hold down the push rod seat while removing the plunger retainer from the lifter body using Retainer Remover J-5238. See Figure 60-80. Remove push rod seat and plunger from lifter body.

6. If a plunger sticks in lifter body, place lifter in large end of Plunger Remover J-4160-A with plunger inward. While holding lifter with thumb, rap the open end of remover against a block of wood with just enough force to jar the plunger from body. See Figure 60-81.

7. Drain oil out of body into waste can and remove the ball retainer, ball, ball spring, and plunger

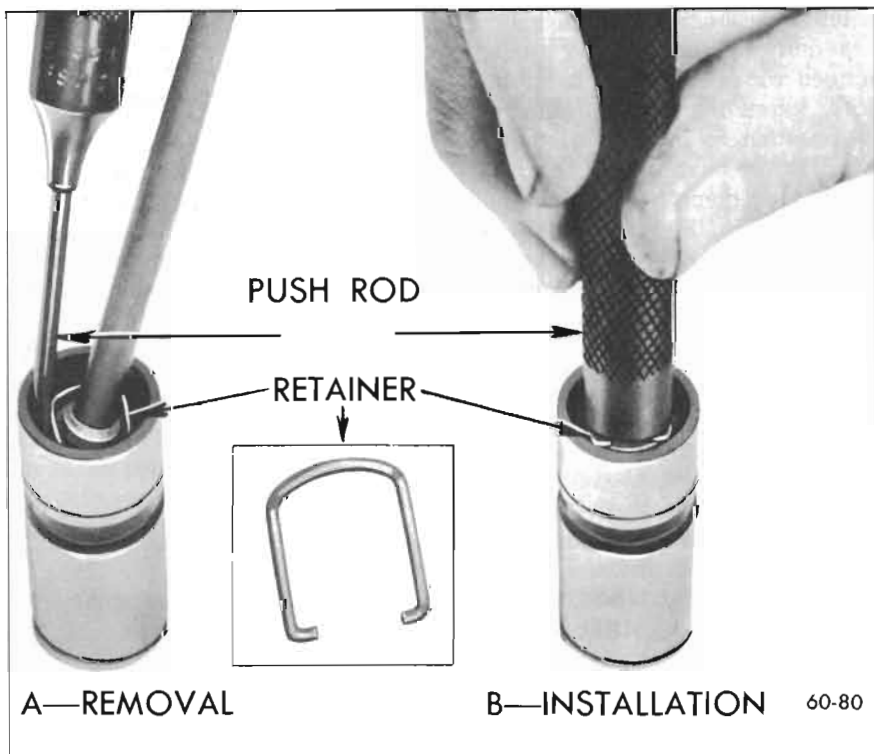

Figure 60-80—Removing and Installing Plunger Retainer

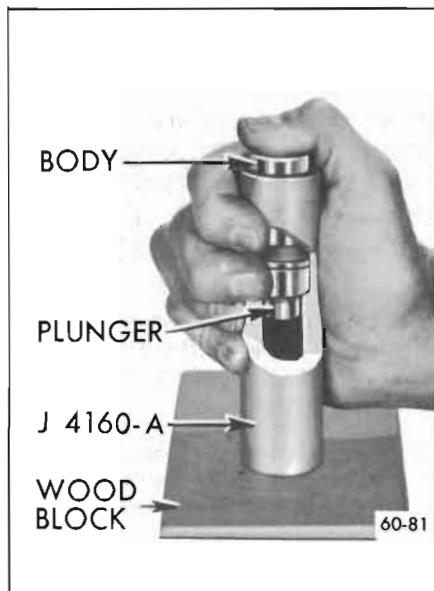

Figure 60-81—Removing Stuck Plunger With J-4160-A

spring. A strainer placed over waste can will prevent dropping these parts into can.

8. Place all parts of each lifter in a separate compartment of a tray.

The body and plunger are selectively fitted to each other and must not be interchanged with parts of other lifters. Keeping all parts of the lifter together until cleaned and inspected will aid in diagnosing cause of improper operation.

9. Rinse the tray full of lifter parts in a pan of kerosene to remove as much oil as possible. This will reduce contamination of the cleaning solvent and extend its effective life.

10. Submerge the tray and parts in the cleaning solvent and leave to soak for approximately one hour. The time required will depend on the varnish on lifter parts and the effectiveness of the solvent.

11. After the varnish has dissolved or has softened sufficiently to permit removal by wiping, raise the tray and allow tray and

parts to drain so that solvent will be saved.

12. Rinse the tray of parts in the pan of kerosene to cut the solvent and avoid injury to hands.

13. Working on one lifter at a time and using CLEAN lint-free cloths, thoroughly wipe off all parts. Clean the plunger and the external and internal surfaces of the body with a hard wiping action to remove any varnish deposits. Rinse the parts in the kerosene using Cleaning Brush J-5099 in the bore of lifter body.

**NOTE:** To insure absolute cleanliness of a reconditioned lifter assembly, it is advisable to inspect and assemble each lifter before cleaning the next lifter.

14. The following list outlines the inspection of lifter parts. An inspection should be made at this point to determine whether or not a lifter is in need of replacement.

(a) Lifter Body. Inspect inner and outer surfaces of body for blow holes and scoring. Replace lifter assembly if body is roughly scored or grooved, or has a blow hole extending through the wall in position to permit oil leakage from lower chamber. The prominent wear pattern just above lower end of body should not be considered a defect unless it is definitely grooved or scored; it is caused by side thrust of cam against body while the lifter is moving vertically in its guide.

Inspect the cam contact surface on lower end of lifter body. Replace the lifter assembly if this surface is excessively worn, galled, or otherwise damaged. A lifter body that has been rotating will have a round wear pattern and a non-rotating lifter body will have a square wear pattern with a very slight depression near the center.

(b) Lifter Plunger. Using a magnifying glass, inspect the check

ball seat for defects. Inspect outer surface of plunger for scratches or scores. Small score marks with a rough, satiny finish will cause the plunger to seize when hot but operate normally when cool. Defects in check ball seat or scores or scratches on outer surface of plunger which may be felt with a fingernail are causes for replacing the lifter assembly. This rule does not apply to the slight edge which may sometimes be present where the lower end of plunger extends below the ground inner surface of the body. This edge is not detrimental unless it is sharp or burred.

A blackened appearance is not a defective condition. Sometimes the discoloration serves to highlight slight grinder chatter marks and give the outer surface of plunger a ridged or fluted appearance. This condition will not cause improper operation, therefore it may be disregarded.

(c) Push Rod and Seat. Replace the push rod seat if the area where the push rod contacts is rough or otherwise damaged. Replace any push rod having a rough or damaged ball end.

(d) Check ball. Using a magnifying glass, carefully examine the check ball for nicks, imbedded material or other defects which would prevent proper seating. Such defects would indicate the cause of intermittently noisy lifter operation. Even though no defects are found it is always advisable to discard the old ball and use a new one when reassembling the lifter.

(e) Check Ball Spring. Examine check ball spring for wear or damage. Replace any spring that is distorted or shows evidence of wear.

(f) Ball Retainer. Replace a retainer which is cracked or which has a heavily pounded area between the two holes. A small



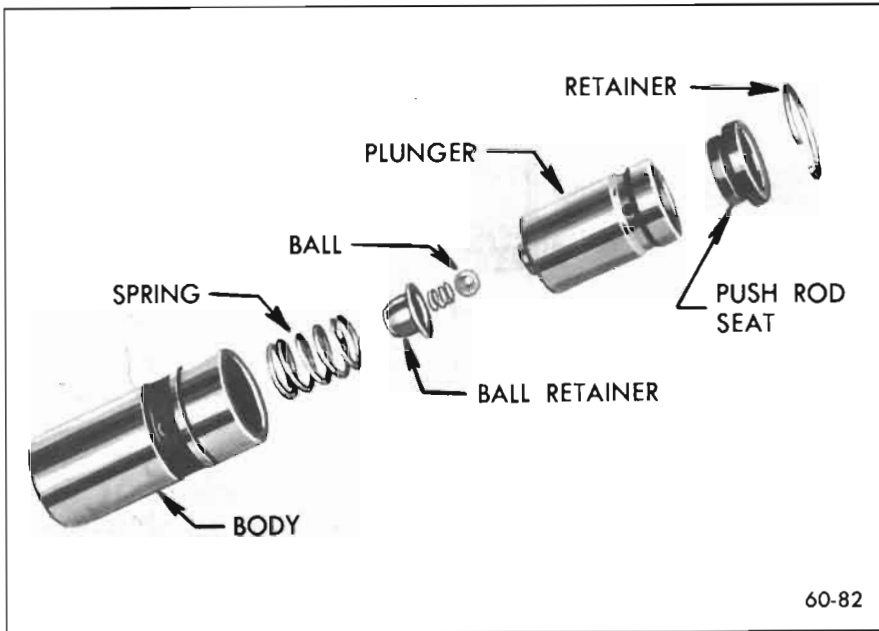

Figure 60-82—Hydraulic Valve Lifter Parts

bright spot where the ball contacts the retainer is the normal condition.

(g) **Plunger Spring.** Replace the plunger spring only if it is distorted or damaged. Exhaustive tests have shown that plunger springs seldom break down in service.

15. Rinse lifter plunger in the kerosene in middle compartment of cleaning tank and then give it a thorough final rinsing in the kerosene in right compartment.

16. Hold plunger in vertical position with feed hole up, then rinse and install the check ball, check ball spring, ball retainer, spring, and body over the plunger. See parts in Figure 60-82.

17. Rinse push rod seat and plunger retainer, place these parts in end of body and depress with handle of Remover J-5238 until retainer engages groove in body. See Figure 60-80, View B.

18. Wrap the lifter in clean paper or otherwise protect it from dirt while reconditioning the other valve lifters, preparatory to testing all lifters for leakdown rate.

19. Check lifter leakdown rate according to subparagraph e below.

20. Make certain that valve lifter guide holes and adjacent area of cylinder block are clean. Liberally lubricate the camshaft and lifter bores with "Service MS" oil and install lifters. Each lifter must slide freely in its guide hole. If a lifter is tight in one guide hole, fit it into another hole where a free fit can be obtained.

21. Following the procedure outlined in paragraph 61-1, subparagraph b, Steps 7-19, reassemble engine.

#### e. Checking Valve Lifter Leakdown Rate

After a hydraulic lifter has been cleaned, inspected, and assembled it must be tested before it is installed in an engine. Lifter Test Fixture J-5790 has been designed to test the leakdown rate of a lifter to determine whether it is within limits which assure satisfactory lifter operation.

The following procedure must be carefully followed to obtain an accurate test.

1. Thoroughly clean the cup of

test fixture, install cup on fixture, and fill it to within 1/2" of the top with "Hydraulic Lifter Test Fluid," which is available through Kent-Moore Organization, Inc., under K-M number J-5268.

2. Remove rubber washer (used for larger lifters) and install Gauge Sleeve J-5180-5 in the cup; also install Gauge Rod Nose J-5180-15 in the ram.

3. Swing the weight arm up out of the way, raise the ram and place the valve lifter (top side up) in Sleeve J-5180-5. The lifter must be completely covered by the fluid during test.

4. Lower the ram to rest in the lifter push rod seat, then lower the weight arm to rest on the roller of ram as shown in Figure 60-83.

5. Operate the lifter plunger through its full travel to force all air out of the lifter by using a vigorous pumping action on the weight arm. Continue the pumping action until considerable resistance is built up in the lifter and a definite grab point is felt at the top of the stroke, when the indicator pointer is at the bottom of the scale.

Finally, pump vigorously for approximately 10 additional strokes to make sure all air is removed from the lifter.

**NOTE:** If one stroke offers noticeable weak resistance during the last 10 pumping strokes replace the check ball in lifter and repeat the leakdown test to this point.

6. Raise weight arm to allow the lifter plunger to come up to its retainer, then lower the arm to rest on the ram roller. As the pointer starts moving upward start rotating the fluid cup by turning the handle one revolution every two seconds.

7. Use a stop watch to check the time required for pointer to move from the lower to the upper mark

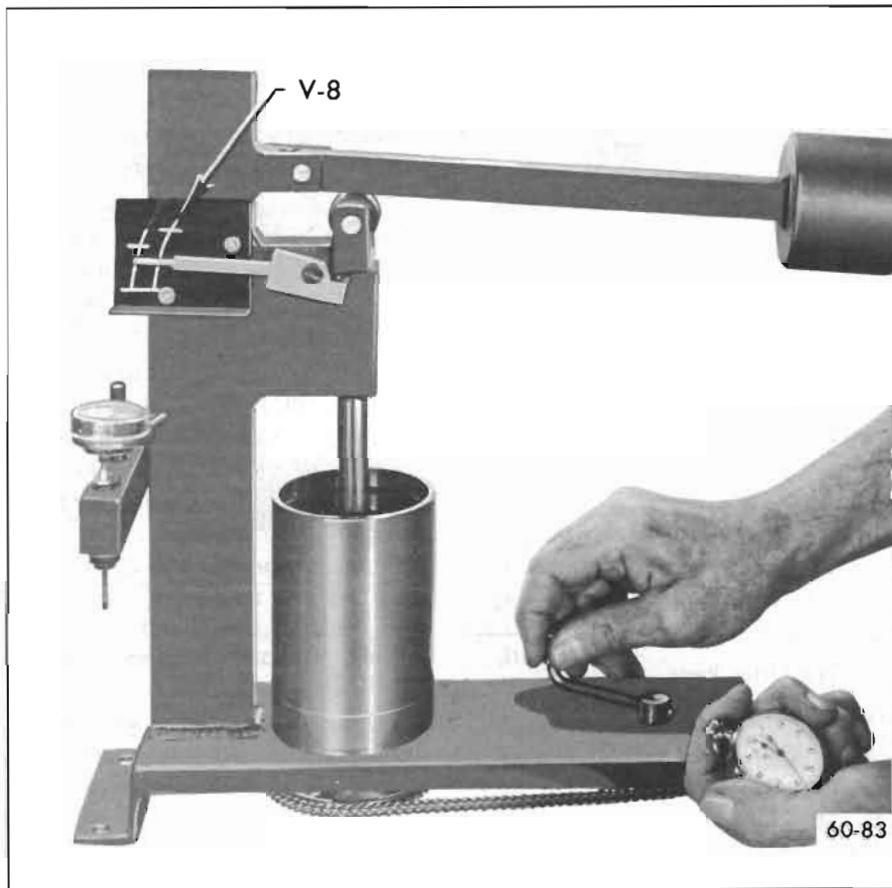

Figure 60-83—Checking Lifter Leakdown Rate

on scale where marked "BUICK V-8." The cup must be rotated during this test.

8. The leakdown rate (time between marks) must be between 12 and 60 seconds to assure satisfactory lifter performance. A doubtful lifter should be tested three or four times. Replace any lifter which does not test within the specified limits.

9. After all lifters have been tested, place the cover over the test fixture to keep dirt out of the cup and fluid. The fluid should be discarded and the cup should be thoroughly cleaned after a few sets of lifters have been tested.

### 61-2 CONNECTING ROD BEARINGS

A connecting rod bearing consists of two halves or shells which are interchangeable in rod and cap. When the shells are placed in po-

sition, the ends extend slightly beyond the parting surfaces so that when the rod bolts are tightened the shells will be clamped tightly in place to insure positive seating and to prevent turning. The ends of the bearing shells must never be filed flush with parting surface of rod or cap.

If a rod bearing becomes noisy or is worn so that clearance on the crankpin is excessive, a new bearing of proper size must be selected and installed since no provision is made for adjustment. Under no circumstances should the connecting rod or cap be filed to adjust the bearing clearance.

#### a. Inspection of Connecting Rod Bearings and Crankpin Journals

After removal of engine oil disconnect two connecting rods at a

time from crankshaft and inspect the bearings and crankpin journals. While turning crankpin it is necessary to temporarily reconnect the rods to crankshaft to avoid possibility of damaging the journals through contact with loose rods.

If connecting rod bearings are chipped or scored they should be replaced. If bearings are in good physical condition check for proper clearance on crankpin as described in subparagraph b, below.

If crankpin journals are scored or ridged the crankshaft must be replaced, or reground for undersize bearings, to insure satisfactory life of connecting rod bearings. Slight roughness may be polished out with fine grit polishing cloth thoroughly wetted with engine oil. Burrs may be honed off with a fine oil stone.

Use an outside micrometer to check crankpins for out-of-round. If crankpins are more than .0015" out-of-round, satisfactory life of new bearings cannot be expected.

#### b. Checking Clearance and Selecting Replacement Bearings

Service bearings are furnished in standard size and several undersizes (including undersizes for reground crankpins).

The clearance of connecting rod (and crankshaft) bearings may be

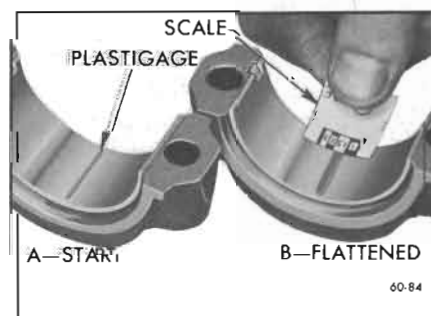

Figure 60-84—Checking Bearing Clearance With Plastigage

checked by use of Plastigage, Type PG-1 (green), which has a range of .001" to .003". Plastigage is manufactured by Perfect Circle Corporation, and is available through General Motors parts warehouses.

1. Remove connecting rod cap with bearing shell. Wipe oil from bearing and crankpin journal, also blow oil out of hole in crankshaft.

**NOTE:** Plastigage is soluble in oil.

2. Place a piece of Plastigage lengthwise along the bottom center of the lower bearing shell (Figure 60-84, View A), then install cap with shell and tighten bolt nuts to 50 lb. ft. torque.

**NOTE:** The rib on edge of cap and the conical boss on web of rod must be toward rear of engine on all rods in left bank and toward front of engine in right bank.

3. DO NOT TURN CRANKSHAFT with Plastigage in bearing.

4. Remove bearing cap with bearing shell, the flattened Plastigage will be found adhering to either the bearing shell or the crankpin. Do not remove it.

5. Using the scale printed on the Plastigage envelope, measure the flattened Plastigage at its widest point. The number within the graduation which most closely corresponds to the width of Plastigage indicates the bearing clearance in thousandths of an inch. See Figure 60-84, View B.

6. The desired clearance with a new bearing is .0020" to .0023". If bearing has been in service it is advisable to install a new bearing if the clearance exceeds .003"; however, if bearing is in good condition and is not being checked because of bearing noise, it is not necessary to replace the bearing.

7. If a new bearing is being selected, try a standard size, then each undersize bearing in turn

until one is found that is within the specified limits when checked for clearance with Plastigage.

**NOTE:** Each undersize bearing shell has a number stamped on outer surface on or near the tang to indicate amount of undersize.

8. After the proper size bearing has been selected, clean off the Plastigage, oil the bearing thoroughly, reinstall cap with bearing shell and tighten bolt nuts to 30-40 lb. ft. torque. See NOTE in Step 2.

9. With selected bearing installed and bolts tightened, it should be possible to move connecting rod freely back and forth on crankpin as allowed by end clearance. If rod cannot be moved, either the bearing is too much undersize or a misaligned rod is indicated.

### 61-3 CRANKSHAFT BEARINGS AND SEALS

#### a. Replacement of Crankshaft Bearings

A crankshaft bearing consists of two halves or shells which are not alike and not interchangeable in cap and crankcase. The upper (crankcase) half of the bearing is grooved to supply oil to the connecting rod bearings while the lower (bearing cap) half of the shell is not grooved. The two bearing halves must not be interchanged. All crankshaft bearings except the thrust bearing are identical. The thrust bearing (Center) and the rear main bearing is longer and flanged to take end thrust. When the shells are placed in crankcase and bearing cap, the ends extend slightly beyond the parting surfaces so that when cap bolts are tightened the shells will be clamped tightly in place to insure positive seating and to prevent turning. The ends of shells must never be filed flush with parting surface of crankcase or bearing cap.

If the thrust bearing shell is disturbed or replaced it is necessary to line up the thrust surfaces of

the bearing shell before the cap bolts are tightened. To do this, move the crankshaft fore and aft the limit of its travel several times (the last movement fore) with the bearing cap bolts finger tight.

Crankshaft bearings are the precision type which do not require reaming to size or other fitting. Shims are not provided for adjustment since worn bearings are readily replaced with new bearings of proper size. Bearings for service replacement are furnished in standard size and undersizes. Under no circumstances should crankshaft bearing caps be filed to adjust for wear in old bearings.

After removal of lower crankcase, oil pump pipe and screen and flywheel lower housing (manual) or bell housing cover (automatic transmission) perform the following removal, inspection and installation operations on each crankshaft bearing in turn so that the crankshaft will be well supported by the other bearings.

**NOTE:** If crankshaft has been removed to check straightness the following procedure is suggested.

Rest crankshaft on "veeblocks" at number one and number five main bearing journals. Check indicator runout at No. 2, 3 and 4 main bearing journals. Total indicator readings at each journal should not exceed .003".

While checking runout at each journal note relation of "high" spot (or maximum eccentricity) on each journal to the others.

"High" spot on all journals should come at the same angular location. If "high" spots do not come at nearly the same angular location, crankshaft has a "crook" or "dogleg" in it and is unsatisfactory for service.



1. Since any service condition which affects the crankshaft bearings may also affect the connecting rod bearings, it is advisable to inspect connecting rod bearings first. If crankpins are worn to the extent that crankshaft should be replaced or reground, replacement of crankshaft bearings only will not be satisfactory.

2. Remove one bearing cap, then clean and inspect lower bearing shell and the crankshaft journal. If journal surface is scored or ridged, the crankshaft must be replaced or reground to insure satisfactory operation with new bearings. Slight roughness may be polished out with fine grit polishing cloth thoroughly wetted with engine oil, and burrs may be honed off with a fine stone.

3. If condition of lower bearing shell and crankshaft journal is satisfactory, check the bearing clearance with Plastigage as described for connecting rod bearings in paragraph 61-2, subparagraph b.

4. When checking a crankshaft bearing with Plastigage, turn crankshaft so that oil hole is up to avoid dripping of oil on Plastigage. Place paper shims in lower halves of adjacent bearings and tighten cap bolts to take the weight of crankshaft off the lower shell of bearing being checked.

5. If bearing clearance exceeds .003", it is advisable to install a new bearing; however, if bearing is in good condition and is not

being checked because of bearing noise, it is not necessary to replace the bearing.

6. Loosen all crankshaft bearing cap bolts 1/2 turn, and remove cap of bearing to be replaced.

7. Remove upper bearing shell by inserting Bearing Shell Remover and Installer J-8080 in oil hole in crankshaft, then slowly turning crankshaft so that the tool rotates the shell out of place by pushing against the end without the tang. See Figure 60-86.

**CAUTION:** When turning crankshaft with rear bearing cap removed hold oil seal to prevent it from rotating out of position in crankcase.

8. The crankshaft journal cannot be measured with an outside micrometer when shaft is in place; however, when upper bearing shell is removed the journal may be checked for out-of-round by using a special crankshaft caliper and inside micrometer. The caliper should not be applied to journal in line with oil hole.

If crankshaft journal is more than .0015" out-of-round, the crankshaft should be replaced since the full mileage cannot be expected from bearings used with an excessively out-of-round crankshaft.

9. Before installation of bearing shells make sure that crankshaft journal and the bearing seats in crankcase and cap are thoroughly cleaned.

10. Coat inside surface of upper bearing shell with engine oil and place shell against crankshaft journal so that tang on shell will engage notch in crankcase when shell is rotated into place.

**IMPORTANT:** Upper bearing shells have an oil groove in their center, while lower shells are plain. They must not be interchanged.

11. Rotate bearing shell into place as far as possible by hand,

then insert Installer J-8080 in crankshaft oil hole and rotate crankshaft to push shell into place.

**CAUTION:** Bearing shell should move into place with very little pressure. If heavy pressure is required, shell was not started squarely and will be distorted if forced into place.

12. Place lower bearing shell in bearing cap, then check clearance with Plastigage as previously described.

13. The desired clearance with a new bearing is .0004" to .0015". If this clearance cannot be obtained with a standard size bearing, insert an undersize bearing and check again with Plastigage.

**NOTE:** Each undersize shell has a number stamped on outer surface on or near the tang to indicate amount of undersize.

14. When the proper size bearing has been selected, clean out all Plastigage, oil the lower shell and reinstall bearing cap. Clean the bolt holes and lube bolts, then torque cap bolts to specification given in paragraph 60-1. The crankshaft should turn freely at flywheel rim; however, a very slight drag is permissible if an undersize bearing is used.

15. If the thrust bearing shell is disturbed or replaced it is neces-



Figure 60-85—Removal and Installation of Crankshaft Bearing Upper Shell

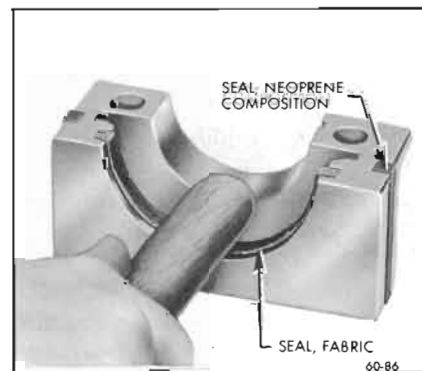

Figure 60-86—Installing Rear Bearing Oil Seals

sary to line up the thrust surfaces of the bearing shell before the cap bolts are tightened. To do this, move the crankshaft fore and aft the limit of its travel several times (last movement fore) with the thrust bearing cap bolts finger tight.

16. After bearing is installed and tested, loosen all bearing cap bolts 1/2 turn and continue with other bearings. When bearings have been installed and tested, tighten all bearing cap bolts to specification given in paragraph 60-1.

17. Refer to subparagraph b for replacement of rear bearing oil seals.

18. Install oil pump, pipe and screen assembly following procedure outlined in paragraph 62-1.

19. Thoroughly clean engine oil pan prior to installation. Use new gaskets when installing, and torque pan bolts to 9-13 lb. ft.

20. Reinstall steering idler arm to front frame horn.

#### b. Installation of Rear Bearing Oil Seals

Braided fabric seals are pressed into grooves formed in crankcase and rear bearing cap to rear of the oil collecting groove, to seal against leakage of oil around the crankshaft.

Neoprene composition seals are placed in grooves in the sides of bearing cap to seal against leakage in the joints between cap and crankcase. The neoprene composition swells in the presence of oil and heat. The seals are under-size when newly installed and may even leak for a short time until the seals have had time to swell and seal the opening. See Figure 60-86.

The braided fabric seal can be installed in crankcase only when crankshaft is removed; however, the seal can be replaced in cap whenever cap is removed. Remove old seal and place new seal in groove with both ends project-

ing above parting surface of cap. Force seal into groove by rubbing down with hammer handle or smooth stick until seal projects above the groove not more than 1/16". Cut ends off flush with surface of cap, using sharp knife or razor blade. Lube the seal with heavy engine oil just before installation. See Figure 60-86.

**CAUTION:** The engine must be operated at slow speed when first started after new braided seal is installed.

The neoprene composition seals are slightly longer than the grooves in the bearing cap. The seals must not be cut to length. Just before installation of bearing cap in crankcase, lightly lubricate the seals and install in bearing cap with upper end protruding approximately 1/16".

After cap is installed, force seals up into the cap with a blunt instrument to be sure of a seal at the upper parting line between the cap and case.

#### 61-4 PISTON, RINGS, AND CONNECTING RODS

##### a. Replacement, Disassembly, and Inspection of Piston and Rod Assemblies

1. Remove cylinder heads. (par. 61-1, subpar. a)

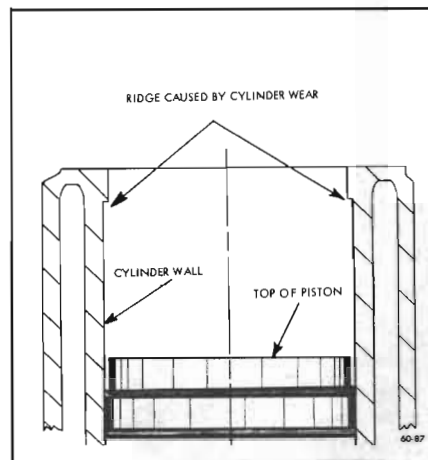

Figure 60-87—Ridge Formed By Rings At Top Of Travel

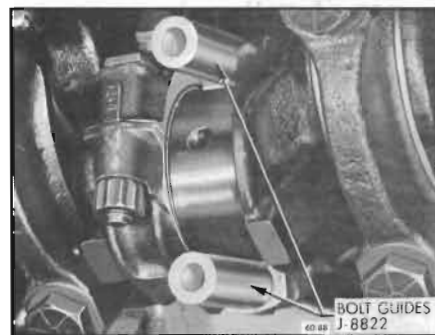

Figure 60-88—Connecting Rod Bolt Guides Installed

2. Examine the cylinder bores above the ring travel. If bores are worn so that a shoulder or ridge exists at the top of the cylinder, remove the ridges with a ridge reamer to avoid damaging rings or cracking ring lands in pistons during removal. See Figure 60-87.

3. Use a silver pencil or quick drying paint to mark the cylinder number on all pistons, connecting rods and caps. Starting at the front end of the crankcase the cylinders in the right bank are numbered 2-4-6-8. Those in the left bank are numbered 1-3-5-7.

4. Remove cap and bearing shell from #1 connecting rod. Install connecting rod bolt guides on the bolts to hold the upper half of the bearing shell in place. See Figure 60-88.

5. Push the piston and rod assembly up and out of the cylinder. Then remove guides and reinstall cap and bearing shell on rod.

6. Remove other rod and piston assemblies in the same manner.

7. Remove compression rings with expander and remove oil ring by removing the two rails, and spacer-expander which are separate pieces in each piston third groove.

8. To remove piston pin:

(a) Install Piston Pin Pilot J-6047-20 in base of hydraulic

press. Install support with face upward.

(b) Set piston, pin and rod in press with J-8355 inserted in piston pin.

(c) Press out piston pin.

9(a) Inspect cylinder walls for scoring, roughness, or ridges which indicate excessive wear. Check cylinder bores for taper and out-of-round with an accurate cylinder gauge at top, middle and bottom of bore, both parallel and at right angles to the centerline of the cylinder bores at any point may be measured with an inside micrometer or by setting the cylinder gauge dial at "O" and measuring across the gauge contact points with outside micrometer while the gauge is at same "O" setting.

(b) If a cylinder bore is moderately rough or slightly scored but is not out-of-round or tapered, it is usually possible to remedy the situation by honing the bore to fit a standard service piston since standard service pistons are high limit production pistons. If cylinder bore is very rough or deeply scored, however, it may be necessary to rebore the cylinder to fit an oversize piston in order to insure satisfactory results.

(c) If cylinder bore is tapered .005" or more or is out-of-round .003" or more, it is advisable to rebore for the smallest possible oversize piston and rings.

10. Clean carbon from piston surfaces and under side of piston heads. Clean carbon from ring grooves with suitable tool and remove any gum or varnish from piston skirts with suitable solvent.

11. Carefully examine pistons for rough or scored bearing surfaces, cracks in skirt or head cracked or broken ring lands, chipping or uneven wear which would cause rings to seat improperly or have excessive clearance in ring

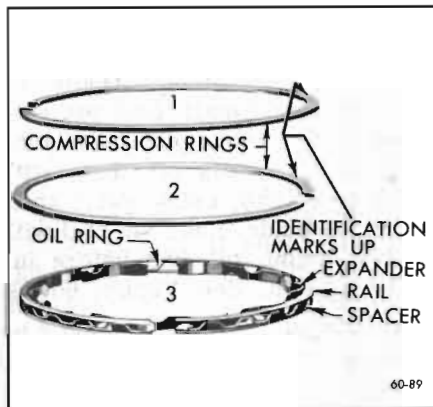

Figure 60-89—Piston Rings

grooves. Damaged or faulty pistons should be replaced.

The pistons are cam ground, which means that the diameter at a right angle to the piston pin is greater than the diameter parallel to the piston pin. When a piston is checked for size, it must be measured with micrometers applied to the skirt at points 90° to the piston pin. See Figure 60-90. The piston should be measured (for fitting purposes) 1/4 below the bottom of the oil ring groove.

12. Inspect bearing surfaces of piston pins and check for wear by measuring worn or unworn surfaces with micrometers. Rough or worn pins should be replaced. Test fit of piston pins in piston bosses. Occasionally pins will be found tight due to gum or varnish deposits. This may be corrected by removing the deposit with a suitable solvent. If piston bosses



Figure 60-90—Measuring Piston

are worn out-of-round or oversize, the piston and pin assembly must be replaced. Oversize pins are not practical due to the pin being a press fit in the connecting rod. Piston pins must fit the piston with an easy finger push at 70°F (.0003" to .005" clearance).

13. Examine all piston rings for scores, chips or cracks. Check compression rings for tension by comparing with new rings. Check gap of compression rings by placing rings in bore at bottom of ring travel. Measure gap with feeler gauge. Gap should be between .010" and .020". If gaps are excessive (over .020") it indicates the rings have worn considerably and should be replaced.

#### b. Reboring Cylinders and Fitting New Pistons

If one or more cylinder bores are rough, scored, or worn beyond limits prescribed under subparagraph b, it will be necessary to smooth or true up such bores to fit new pistons.

If relatively few bores require correction it will not be necessary to rebore all cylinders to the same oversize in order to maintain engine balance, since all oversize service pistons are held to the same weights as standard size pistons. If conditions justify replacement of all pistons, however, all new pistons should be the same nominal size.

Standard size service pistons are high limit or maximum diameter; therefore, they can usually be used with a slight amount of honing to correct slight scoring or excessive clearances in engines having relatively low mileage. Service pistons are also furnished in .010" oversize. All service pistons are diamond bored and selectively fitted with piston pins; pistons are not furnished without pins.

No attempt should be made to cut down oversize pistons to fit cylinder bores as this will destroy the surface treatment and affect the weight. The smallest possible oversize service pistons should be used and the cylinder bores should be honed to size for proper clearances.

Before the honing or reboring operation is started, measure all new pistons with micrometer contacting at points exactly 90 degrees to piston pin (Figure 60-90) then select the smallest piston for the first fitting. The slight variation usually found between pistons in a set may provide for correction in case the first piston is fitted too free.

If wear at top of cylinder does not exceed .005" on the diameter or exceed .003" out-of-round, honing is recommended for truing the bore. If wear or out-of-round exceeds these limits, the bore should be trued up with a boring bar of the fly cutter type, then finish honed.

When reboring cylinders, all crankshaft bearing caps must be in place and tightened to proper torque to avoid distortion of bores in final assembly. Always be sure the crankshaft is out of the way of the boring cutter when boring each cylinder. When taking the final cut with boring bar leave .001" on the diameter for finish honing to give the required clearance specified below.

When honing cylinders use clean sharp stones of proper grade for the amount of metal to be removed, in accordance with instructions of the hone manufacturer. Dull or dirty stones cut unevenly and generate excessive heat. When using coarse or medium grade stones use care to leave sufficient metal so that all stone marks may be removed with the fine stones used for finishing to provide proper clearance.

When finish honing, pass the hone

through the entire length of cylinder at the rate of approximately 60 cycles per minute. This should produce the desired 45 degree cross hatch pattern on cylinder walls which will insure maximum ring life and minimum oil consumption.

It is of the greatest importance that refinished cylinder bores are trued up to have not over .0005" out-of-round or taper. Each bore must be final honed to remove all stone or cutter marks and provide a smooth surface. During final honing, each piston must be fitted individually to the bore in which it will be installed and should be marked to insure correct installation.

After final honing and before the piston is checked for fit, each cylinder bore must be thoroughly washed to remove all traces of abrasive and then dried thoroughly. The dry bore should then be brushed clean with a power-driven fibre brush. If all traces of abrasive are not removed, rapid wear of new pistons and rings will result. A satisfactory method of fitting pistons is as follows:

1. Expand a telescope gauge to fit the cylinder bore at right angles to the piston pin and between 1-1/2" and 2" from the top. See Figure 60-91.
2. Measure the telescope gauge. See Figure 60-92.

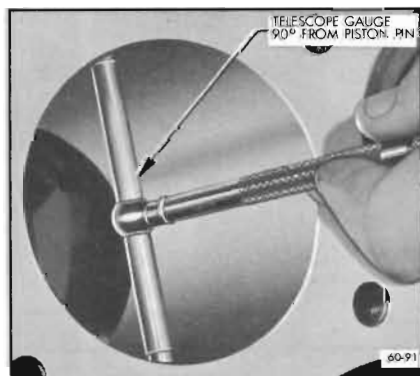

Figure 60-91—Checking Cylinder Bore

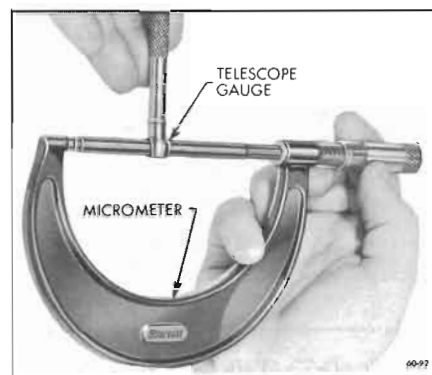

Figure 60-92—Measuring Telescope Gauge

3. Measure the piston to be installed. See Figure 60-90. The piston must be measured at right angles to the piston pin 1/4" below the oil ring groove. The piston must be between .001" and .0015" smaller than the cylinder bore.

**NOTE:** Both block and piston must be at very nearly the same temperature when measurements are made or errors due to expansion will occur. A difference of 10°F between parts is sufficient to produce a variation of .0005".

### c. Fitting New Piston Rings

When new piston rings are installed without reboring cylinders, the glazed cylinder walls should be slightly dulled, but without increasing the bore diameter, by means of the finest grade of stones in a cylinder hone.

New piston rings must be checked for clearance in piston grooves and for gap in cylinder bores; however, the flexible oil rings are not checked for gap. The cylinder bores and piston grooves must be clean, dry and free of carbon and burrs.

With rings installed, check clearance in grooves by inserting feeler gauges between each ring and its lower land because any

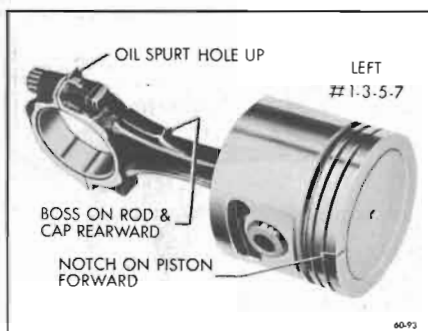

Figure 60-93—Left Bank Piston and Rod Assembly

wear that occurs\*forms a step at inner portion of the lower land. If the piston grooves have worn to the extent that relatively high steps exist on the lower lands, the piston should be replaced because the steps will interfere with the operation of new rings and the ring clearances will be excessive. Piston rings are not furnished in oversize widths to compensate for ring groove wear.

When fitting new rings to new pistons the side clearance of the compression rings should be .003" to .005" and side clearance of the oil ring should be .0035" to .0095".

To check the end gap of compression rings, place the ring in the cylinder in which it will be used, square it in the bore by tapping with the lower end of a piston, then measure the tap with feeler gauges. Piston rings should not have less than .015" gap when placed in cylinder bores. If gap is less than .015", file the ends of rings carefully with a smooth file to obtain proper gap.

#### d. Assembly and Installation of Piston and Connecting Rod Assemblies

**NOTE:** Connecting rods may be sprung out of alignment in shipping or handling. Always check a new rod before installing piston and pin.

Check bend and twist on an accurate rod aligning fixture using

Guide Pin J-6047-16 (from wrist pin press set) in place of wrist pin. Press Vee block firmly and evenly against guide pin to prevent cocking pin in eye of rod which may be up to .002" loose on pin.

1. To assemble piston and pin to connecting rod, assemble press with radial face of Support J-8754-1 in the "up" position.

2. If the piston and rod assembly is to be installed in the left bank, the assembly must be made as shown in Figure 60-93.

3. If the piston and rod assembly is to be installed in the right bank, the assembly must be made as shown in Figure 60-94.

4. Assemble piston and rod on spring loaded guide pin.

5. Lubricate piston pin to avoid damage when pressing through the connecting rod.

6. Install drive pin in upper end of piston pin. Press on drive pin till piston pin bottoms.

7. Remove piston and rod assembly from press. Rotate piston on pin to be sure pin was not damaged during the pressing operation.

8. Install piston rings as shown in Figure 60-96. Position expander ends over piston pin. Install oil ring rail spacer, and oil ring rails. Position gaps in rails "up" on same side of piston as oil

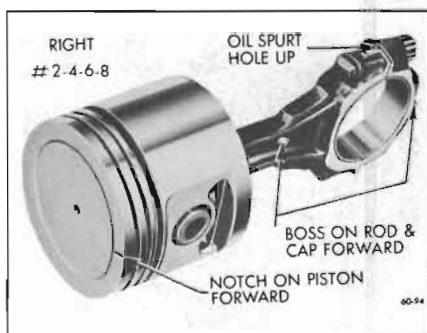

Figure 60-94—Right Bank Piston and Rod Assembly

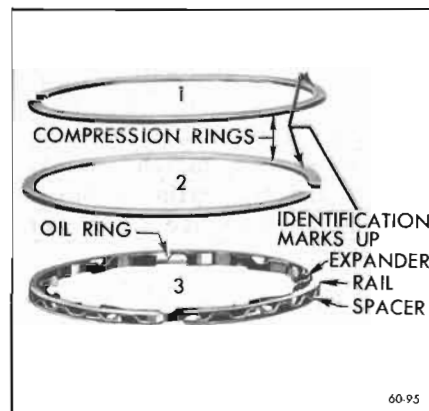

Figure 60-95—Piston Rings

spurt hole in connecting rod. Install compression rings in upper two grooves.

If a single chrome plated compression ring is used, the chrome ring must be installed in the top groove.

a. Top compressing ring - When installed, the bevel on the I.D. of the ring is facing down with the manufacturer's identification mark ("O", "DOT" or "TOP") facing up.

b. Second compression ring - When installed, the bevel on the I.D. of the ring is facing up, as is the manufacturer's identification mark ("O", "DOT" or "TOP").

c. Oil ring - Can be installed with either rail facing up.

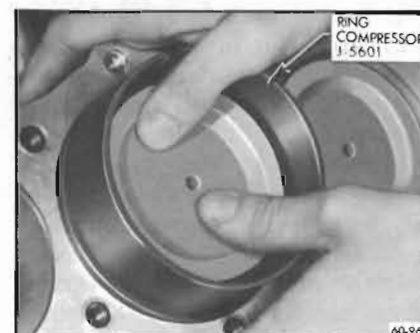

Figure 60-96—Installing Piston With Compressor Installed



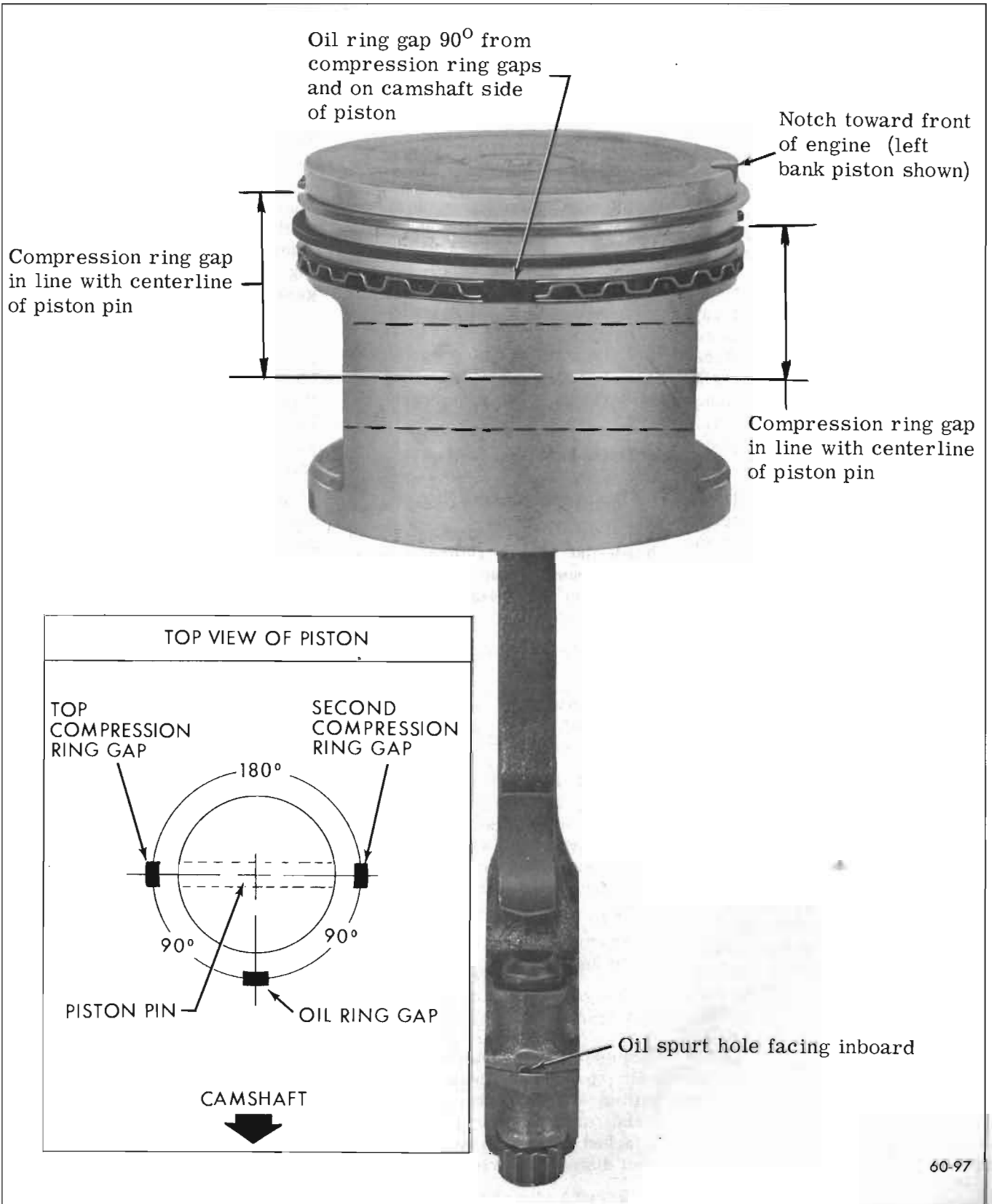

Figure 60-97—Piston Ring Gap Positioning

d. Ring gaps - All three ring gaps must be 90° apart. See Figure 60-97.

9. Make sure cylinder bores, pistons, connecting rod bearings and crankshaft journals are absolutely clean, then coat all bearing surfaces with engine oil.

10. Before installation of a piston and rod assembly in its bore, position the crankpin straight down.

11. Remove connecting rod cap. Retain bearing upper shell in rod and install rod guides. These guides hold the upper bearing shell in place and prevent damage to the crankpin during installation of the connecting rod and piston assembly.

12. Make sure the gap in the oil ring rails is "up" toward center of engine and the gaps of the compression rings are positioned as shown in Figure 60-97.

13. Lubricate the piston and rings and install in bore by compressing the rings either with a "wrap around" compressor or a split ring type such as shown in Figure 60-96.

14. Select new connecting rod bearing, if necessary, as described in paragraph 61-2. Otherwise install cap with bearing lower shell on rod and tighten bolt nuts to 30-40 lb. ft. torque.

15. Install all other piston and rod assemblies in same manner. When piston and rod assemblies are properly installed, the oil spurt holes in the connecting rods will be "up" toward the camshaft, the rib on the edge of the rod cap will be on the same side as the conical boss on the connecting rod web, and these marks, (rib and boss) will be toward the other connecting rod on the same crankpin. See Figure 60-93 and 60-94.

16. Check end clearance between connecting rods on each crankpin using feeler gages. Clear-

ance should be between .005" and .012".

17. Install cylinder head (par. 61-1). Install oil screen and engine oil pan.

**IMPORTANT:** After installation of new pistons and rings, care should be used in starting the engine and running it for the first hour. Avoid high speeds until the parts have had a reasonable amount of "break in" time. This practice will avoid unnecessary "scuffing" of new parts.

## 61-5 CAMSHAFT AND TIMING CHAIN

### a. Timing Chain Cover Removal

1. Drain radiator and block.
2. Disconnect upper radiator hose and heater return hose at water pump, disconnect lower bolts and brackets and remove radiator core.
3. Remove fan, fan pulleys and belt(s).
4. Remove fan driving pulley (crankshaft) and pulley reinforcement.
5. If car is equipped with power steering, remove steering pump bracket bolts attached to timing chain cover and loosen or remove other bolts to allow the brackets and pump to be moved out of the way.
6. Disconnect fuel lines and remove fuel pump.
7. Remove Delcotron generator and brackets.
8. Remove distributor cap and pull spark plug wire retainers off brackets on rocker arm cover. Swing distributor cap with wires attached out of the way. Disconnect distributor primary lead.
9. Remove distributor. If timing chain and sprockets are not going to be disturbed, note position of

distributor rotor for reinstallation in same position.

10. Loosen and slide front clamp on thermostat by-pass hose rearward.

11. Remove bolts attaching timing chain cover to cylinder block. Remove two oil pan to timing chain cover bolts. Remove timing chain cover assembly and gasket. Thoroughly clean the cover, taking care to avoid damage to the gasket surfaces.

### b. Timing Chain Cover Replacement

Reinstall timing chain cover by reversing removal procedure, paying particular attention to the following points.

1. Remove oil pump cover and pack the space around the oil pump gears completely full of petroleum jelly. There must be no air space left inside the pump. Reinstall cover using new gasket. This step is very important as the oil pump may "lose its prime" whenever the pump, pump cover or timing chain cover is disturbed. If the pump is not packed, it may not begin to pump oil as soon as the engine is started.
2. The gasket surface of the block and timing chain cover must be smooth and clean. Use a new gasket and be certain it is positioned correctly.
3. Position timing chain cover against block and be certain dowel pins engage dowel pin holes before starting bolts.
4. Lubricate the bolt threads before installation and install as shown in Figure 60-98.

**NOTE:** If the car is equipped with power steering, the front steering pump should be installed at this time.

### c. Crankshaft Oil Seal Replacement

1. Use a punch to drive out old seal and shedder. Drive from the

front toward the rear of the timing chain cover.

2. Coil new packing around opening so ends of packing are at top. Drive in shedder using suitable punch. Stake the shedder in place in at least three places.

3. Size the packing by rotating a hammer handle or similar tool around the packing until the balancer hub can be inserted through the opening.

#### d. Timing Chain and Sprocket Removal

1. With timing chain cover removed (subpar. a above) temporarily install crankshaft pulley bolt and washer in end of crankshaft. Turn crankshaft so sprockets are positioned as shown in Figure 60-99. Remove crankshaft pulley bolt and washer using a sharp blow on the wrench handle, so that the bolt can be started out without changing position of sprockets.

2. Remove front crankshaft oil slinger.

3. Remove bolt and special washer retaining camshaft distributor drive gear and fuel pump eccentric to camshaft forward end. Slide gear and eccentric off camshaft.

4. Use two large screwdrivers to alternately pry the camshaft sprocket then the crankshaft sprocket forward until the camshaft sprocket is free, then remove the camshaft sprocket and chain and finish working crankshaft sprocket off crankshaft.

5. Thoroughly clean the timing chain, sprockets, distributor drive gear, fuel pump eccentric and crankshaft oil slinger.

#### e. Timing Chain and Sprocket Installation

1. Turn crankshaft so that #1 piston is at top dead center.

2. Turn camshaft so with sprocket temporarily installed, timing mark is straight down. See Figure 60-99. Remove sprocket.

3. Assemble timing chain on sprockets and slide the sprocket and chain assembly on the shafts with the timing marks in their closest together position and in line with the sprocket hubs. See Figure 60-99.

**NOTE:** It will be necessary to hold spring loaded timing chain damper out of the way while sliding chain and sprockets into position.

4. Assemble slinger on crankshaft with I.D. against sprocket. (Concave side toward front of engine).

5. Slide fuel pump eccentric on camshaft and Woodruff key with

oil groove forward. See Figure 60-100.

6. Install distributor drive gear. See Figure 60-100.

7. Install drive gear and eccentric bolt and retaining washer. Torque to 40-55 lb. ft.

8. Reinstall timing chain cover (subpar. b above).

#### f. Camshaft Service

1. Remove rocker arm and shaft assemblies, push rods and valve lifters.

2. Remove timing chain cover, timing chain and sprocket, subparagraph d above.

3. Slide camshaft forward out of bearing bores carefully to avoid marring the bearing surfaces.

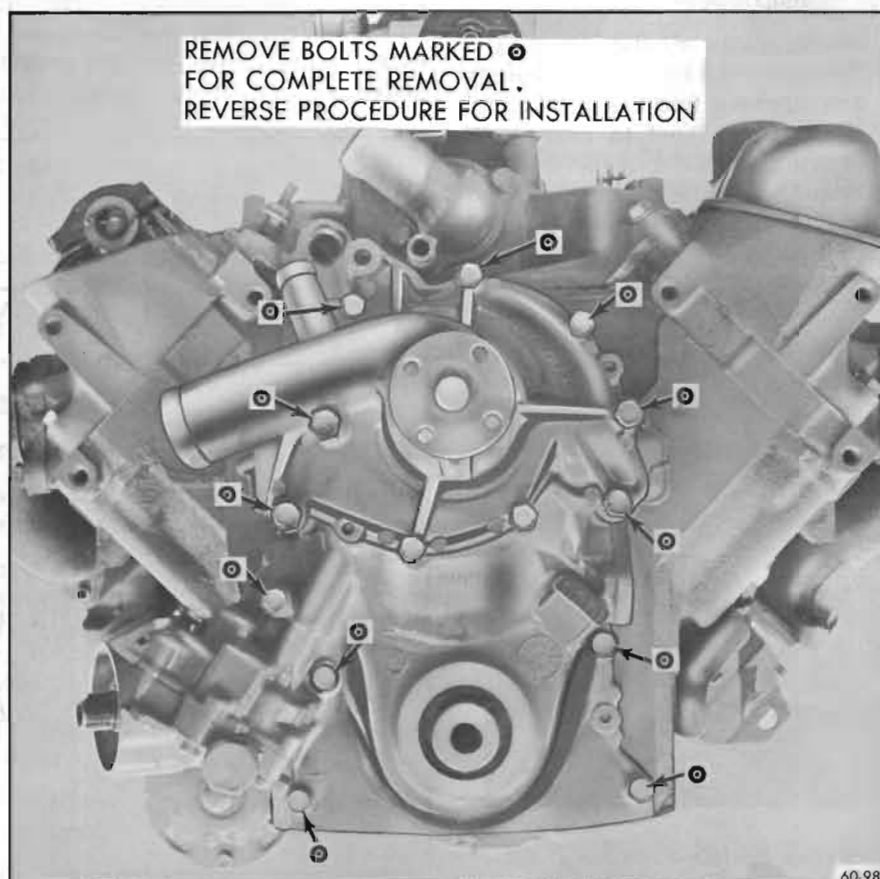

Figure 60-98—Timing Chain Cover Installation



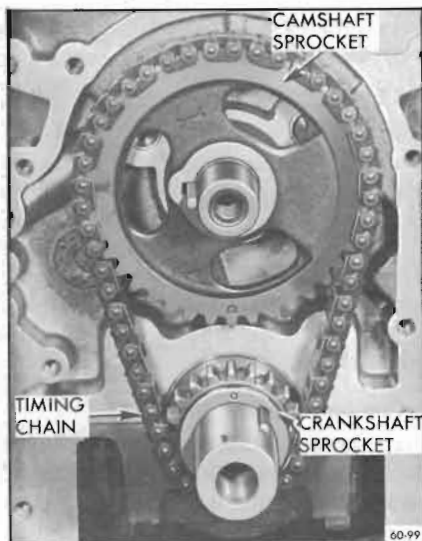

Figure 60-99—Installation of Timing Chain and Sprocket

4. Replace camshaft by reversing removal procedure, taking particular care to avoid damage to the camshaft bearings.

**NOTE:** The steel-backed babbit-lined camshaft bearings are pressed into the crankcase. Going from front to rear, each bearing is bored .030" smaller than the preceding bearing, and each camshaft journal is correspondingly reduced in diameter.



Figure 60-100—Fuel Pump and Distributor Drive Gear Installation

The camshaft bearings must be line reamed to size after being pressed into the crankcase. Since this operation requires special reaming equipment the original bearings should be retained unless severely damaged. Slightly scored camshaft bearings will be satisfactory if the surfaces of camshaft journals are polished and bearings are cleaned up to remove burrs, and the fit of shaft in bearings is free and within the clearance limits of .0015" to .004".

### 62-1 OIL PUMP AND LUBRICATION

#### a. Removal and Inspection of Oil Pump Cover and Gears

1. Remove oil filter.
2. Disconnect wire from oil pressure indicator switch in filter by-pass valve cap.
3. Remove screws attaching oil pump cover assembly to timing chain cover. Remove cover assembly and slide out oil pump gears.

4. Wash off gears and inspect for wear, scoring, etc. Replace any gears not found serviceable.

5. Remove the oil pressure relief valve cap, spring and valve. See Figure 60-101. Oil filter by-pass valve and spring are staked in place and should not be removed.

6. Wash the parts thoroughly and inspect the relief valve for wear or scoring. Check the relief valve spring to see that it is not worn on its side or collapsed. Replace any relief valve spring that is questionable. Thoroughly clean the screen staked in the cover.

7. Check the relief valve in its bore in the cover. The valve should have no more clearance than an easy slip fit. If any perceptible side shake can be felt the valve and/or cover should be replaced.

8. Check filter by-pass valve for cracks, nicks, or warping. The valve should be flat and free of nicks or scratches.

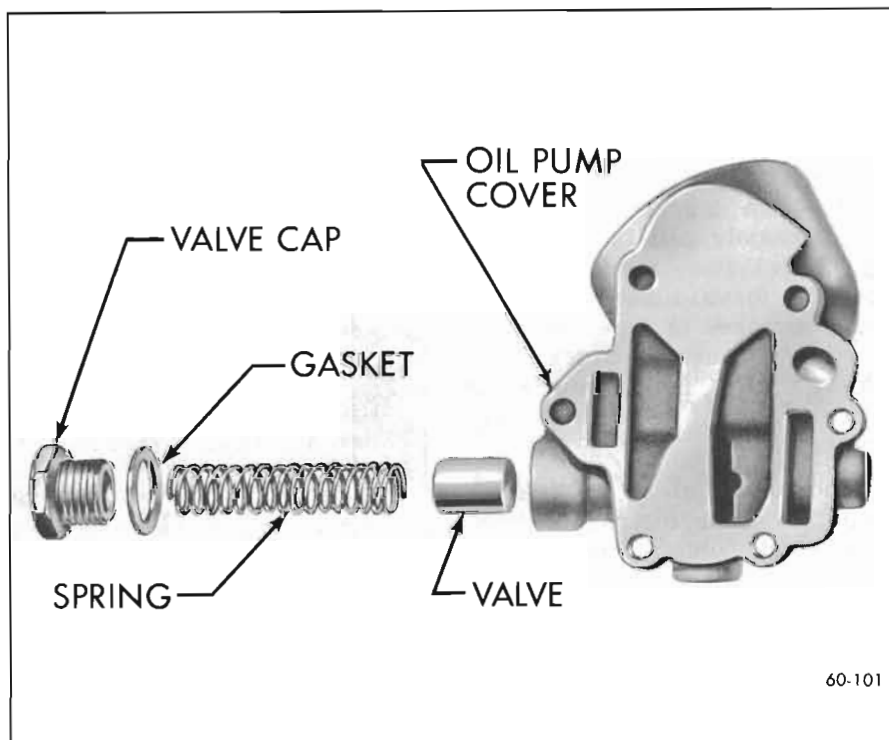

Figure 60-101—Oil Pump Cover and By-Pass Valve



Figure 60-102—Installation of Pipe and Screen Assembly

#### b. Oil Pump Assembly and Installation

1. Lubricate and install pressure relief valve and spring in bore of oil pump cover. See Figure 60-101. Install cap and gasket. Torque cap to 25-30 lb. ft. with a reliable torque wrench. Do not over-tighten.
2. Install oil pump gears and shaft in oil pump body section of timing



Figure 60-103—Checking Oil Pump End Clearance

chain cover to check gear end clearance.

3. Place a straight edge over the gears and measure the clearance between the straight edge and the gasket surface. See Figure 60-103. Clearance should be between .0023" and .0058". If clearance is less than .0018" check timing chain cover gear pocket for evidence of wear.

4. If gear end clearance is satisfactory, remove gears and pack gear pocket full of petroleum jelly. Do not use chassis lube!

5. Reinstall gears so petroleum jelly is forced into every cavity of the gear pocket and between the teeth of the gears. Place new gasket in position.

**NOTE:** This step is very important. Unless the pump is packed with petroleum jelly it may not prime itself when the engine is started.

6. Install cover assembly screws. Tighten alternately and evenly. The torque specification is 8-12 lb. ft.

7. Install filter on nipple.

#### c. Removal and Inspection of Oil Pump Pipe and Screen Assembly

1. Raise car and support on stands.

2. Drain oil.

3. If manual equipped:

- a. Loosen clutch equalizer bracket to frame attaching bolts.

- b. Remove lower flywheel housing.

- c. Remove exhaust crossover pipe.

- d. Remove front engine mounting bolts.

- e. Remove transmission mounting bolts.

- f. Raise transmission by using floor jack.

4. If automatic equipped:

- a. Loosen shift linkage attaching bolts.

- b. Remove steering idler arm bracket to right front frame horn attaching bolts.

- c. Raise engine by placing jack under crankshaft pulley mounting.

5. Remove oil pan bolts and lower pan enough to remove oil pump pipe and screen to cylinder block bolts.

6. Rotate crankshaft to provide maximum clearance at forward end of oil pan.

7. Remove oil pan.

8. Clean oil pan. Pry screen out of housing and examine for evidence of clogging due to deposit of sludge or other foreign material.

9. Clean the screen and housing thoroughly in solvent and blow dry with air stream.

10. Snap screen into housing.

#### d. Installation of Oil Pump and Screen Assembly

Install by reversing removal procedure, paying particular attention to the following points.

1. Make sure oil pump pipe flange gasket surface of block is smooth and free of dirt.

2. Use a new gasket and tighten bolts to 6-9 lb. ft. torque.

3. Tighten pan bolts evenly. Do not over-tighten.

### 62-2 POSITIVE CRANKCASE VENTILATION

#### a. Standard Positive Crankcase Ventilation (Non-California)

All cars equipped with a V-8 engine have a positive crankcase ventilating system to reduce air

pollution and provide more complete scavenging of crankcase impurities. Ventilation air is drawn in through the filter in the filler cap on the left rocker arm cover. From this point, it is drawn down into the crankcase, across and up into the right rocker arm cover, up through the ventilator valve, through a hose and into a carburetor throttle body. Intake manifold vacuum draws any fumes from the crankcase and burns them in the engine.

When air flow through the carburetor is high, added air from the positive crankcase ventilating system has no noticeable effect on engine operation; however, at idle speed, air flow through the carburetor is so low that any large amount added by the ventilating system would upset the air-fuel mixture, causing rough idle. For this reason, a flow control valve is used which restricts the ventilating system flow whenever intake manifold vacuum is high.

After a period of operation, the ventilator valve tends to become clogged, which reduces and finally stops all crankcase ventilation. An engine which is operated without any crankcase ventilation can be damaged seriously. Therefore, it is important to replace the ventilator valve periodically (each 12,000 miles).

**CAUTION:** If an engine is idling too slow or rough, this may be caused by a clogged ventilator valve; therefore, never adjust the idle speed without first checking the crankcase ventilator check valve.

With the crankcase ventilator system operating normally, about 1/4 of the air used in the idle mixture is supplied through the ventilator valve. Therefore, if the ventilator air is shut off, the idle speed will be noticeably slower. Check operation of the ventilator system as follows:

1. Connect a reliable tachometer and adjust idle as specified.
2. Squeeze-off crankcase ventilator hose to stop all air flow.
3. If idle speed drops 60 RPM or more, crankcase ventilator system is functioning properly.
4. If idle speed drops less than 60 RPM, ventilator system is probably partially clogged; install a new ventilator valve and recheck operation of system as described above.
5. After installing a new ventilator valve, always readjust engine idle speed.

#### b. Closed Positive Crankcase Ventilator System

All cars manufactured for registration in California are required to have a closed system. The closed PCV system consists of the standard PCV system plus additional features as shown in Figure 60-104.

The closed PCV system operates in the same manner as the standard PCV system except that the ventilating air is drawn in from the air cleaner, down through a mesh filled breather assembly and into the left rocker arm cover. The oil filler cap is sealed in the closed PCV system. See Figure 60-104.

With the standard PCV system, any blow-by in excess of the system capacity (from a badly worn engine, sustained heavy load, etc.) is exhausted into the air cleaner and is drawn into the engine.

Maintenance of the closed PCV system is essentially the same as the standard PCV system with one exception; instead of cleaning the oil filler cap at 12,000 mile intervals (more often under dusty operating conditions), it is the breather assembly that will be cleaned.

#### 63-1 WATER PUMP AND COOLING SYSTEM

##### a. Checking and Filling Cooling System

The engine coolant level should be checked only when the engine is cold. Enough coolant should be added to bring the level to the tip of the "FILL COLD" arrow on the inside of the filler neck.

**CAUTION:** Never remove the radiator cap quickly when the radiator is hot. Sudden release of cooling system pressure may cause the coolant to boil and escape with some force.

If it becomes necessary to remove the radiator cap when the radiator is hot, rotate the cap slowly counterclockwise until a stop is reached. When all system pressure is released, then remove cap.

##### b. Draining and Flushing the Cooling System

When the cooling system has been drained, reinstall a permanent glycol type corrosion and anti-freeze cooling system protection solution developed for year around use (General Motors Specification GM 1899-M). Water alone, methanol, or alcohol type anti-freeze is definitely not recommended. To drain the cooling system, remove radiator cap, open the drain at the bottom of the radiator and remove the drain plugs on both sides of cylinder block. If car is heater equipped, set heater temperature control valve at "HOT" position.

After the cooling system is drained, plugs reinstalled, and drain cock closed, fill the system with clean water. Run the engine long enough to open the thermostat for complete circulation

60-104

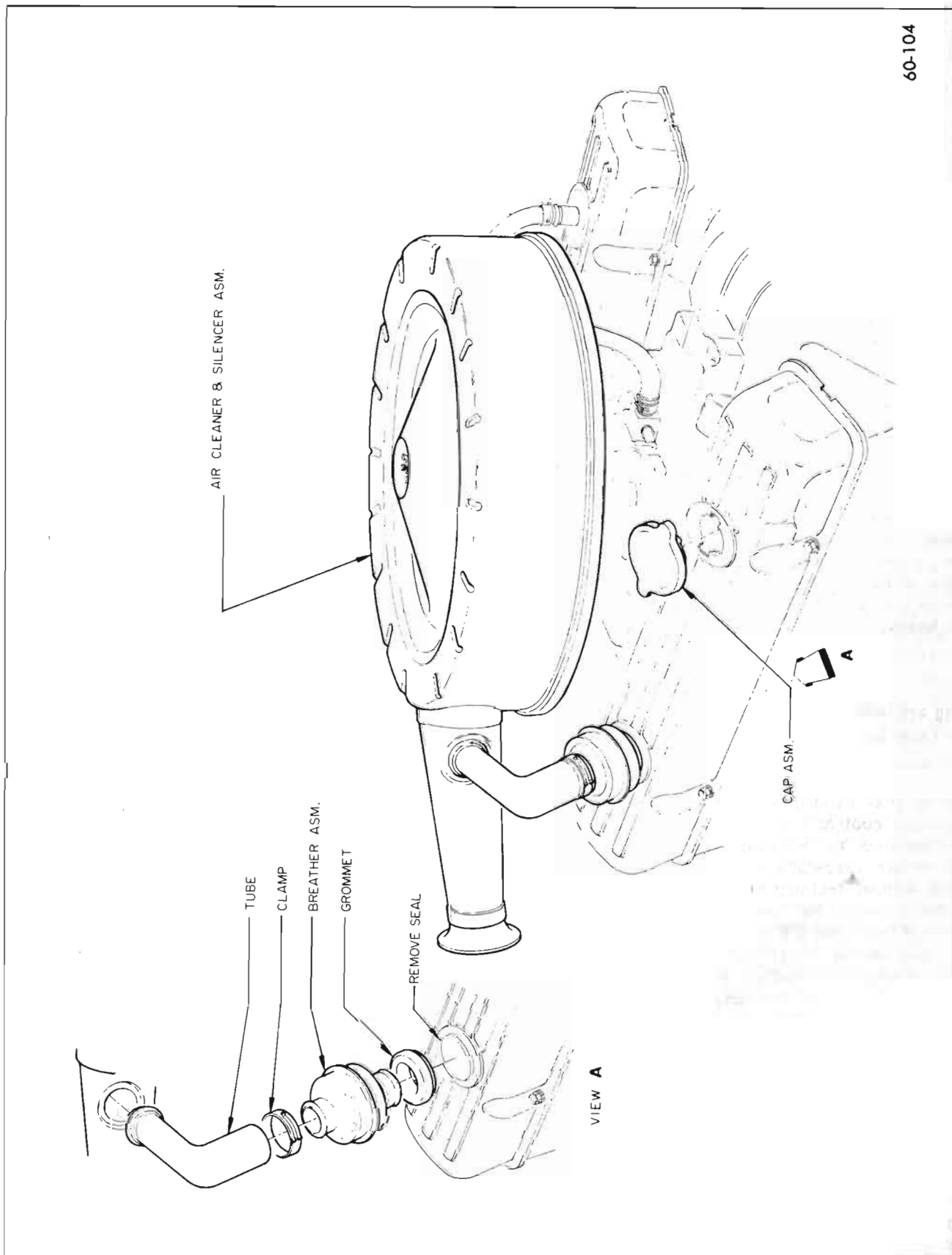

Figure 60-104—Closed Positive Crankcase Ventilation System

through the system then completely drain the cooling system before sediment has a chance to settle.

### c. Conditioning the Cooling System

It is very important to make certain that the cooling system is properly prepared before an anti-freeze solution is installed; otherwise, loss of solution through leakage may occur or seepage may result in damage to the engine. The cooling system should be drained and flushed as described above (subpar. b). All joints should be checked for leakage and corrected.

Inspect the water pump, radiator core, heater core, drain cocks, water jacket plugs, and edge of cylinder head gaskets for evidence of leaks. Tighten all hose clamps in the cooling and heating systems and replace any deteriorated hoses.

### d. Using and Testing Anti-Freeze Solutions

Inhibited year around (permanent type) engine coolant solution which is formulated to withstand two full calendar years of normal operation without draining or adding inhibitors should be used at all times (not less than 0°F. to freeze protection should be provided to protect against corrosion). When adding solution due to loss of coolant for any reason or in areas where temperatures lower than -20°F. may be encountered, a sufficient amount of any of the several brands of year around coolant (Ethylene Glycol base) compatible to GM Specification 1899-M available on the market should be used.

**NOTE:** Alcohol base coolants are not recommended for this

vehicle at any time. If for any reason water is used as a coolant in an emergency, it is extremely important that Buick Heavy Duty Cooling System Protector and Water Pump Lubricant be added to the cooling system as soon as possible. This material is available from the PARTS DEPARTMENT.

If any other cooling system protector is used, be certain it is labeled to indicate that it meets General Motors Specification GM 1894-M. It should be recognized that this is only a temporary measure. The manufacturer intends that permanent type coolant solution be used year around in the cooling system of your Buick. The cooling system should be completely drained and the recommended coolant installed every two years.

It is advisable to check the anti-freeze solution at intervals during the winter to make certain that the solution has not been weakened by evaporation or leakage. Use only hydrometers which are calibrated to read both the specific gravity and the temperature. Obtain a table or similar means of converting the freezing point at various temperatures of the solution. Disregarding the temperature of the solution when making the test may cause an error as large as 30°F. Care must be exercised to use the correct float or table for the particular type of anti-freeze being tested.

### e. Fan Belt Adjustment and Replacement

A tight fan belt will cause rapid wear of the Delcotron generator and water pump bearings. A loose belt will slip and wear excessively causing noise, engine overheating, and unsteady generator output. A fan belt which is cracked or frayed, or is worn so that it bottoms in the pulleys should be replaced.

The fan belt may be replaced by loosening the generator brace at both ends, slightly loosening the generator mounting bolts, and moving generator inward to provide maximum slack in the belt.

The Delcotron generator must be moved sideways to adjust the fan belt. After the Delcotron generator brace and mounting bolts are securely tightened, the fan belt tension should be checked as shown in Figures 60-105 and 60-106.

If the power steering oil pump belt is removed it should be adjusted to tension specified, in Figures 60-105 and 60-106.

If the air conditioner compressor belt is disturbed it should be adjusted as specified, in Figures 60-105 and 60-106.

### f. Radiator Thermostat Inspection and Test

A sticking radiator thermostat will prevent the cooling system from functioning properly. If the thermostat sticks in the open position, the engine will warm up very slowly. If the thermostat sticks in the closed position, overheating will result.

The thermostat may be removed for inspection by partially draining the cooling system and removing the thermostat housing.

If the thermostat valve does not fully close when cold, check for the presence of foreign material that could hold it open. If no foreign material is present and valve still does not close, replace the thermostat.

Test the thermostat for correct opening temperature by immersing the unit and a thermometer in

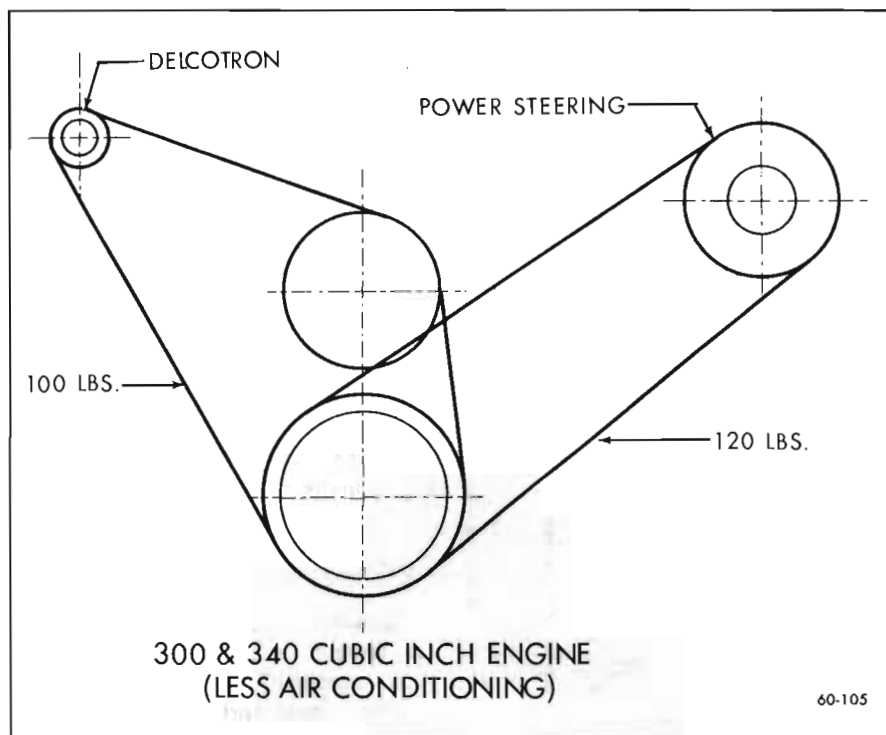

Figure 60-105—Engine Belt Tension Chart - Non-Air Conditioned Cars

a container of water. While heating the water do not rest either the thermometer or thermostat on bottom of container as this will cause them to register a higher temperature than the water. Agitate the water to insure uniform temperature of water, thermostat and thermometer.

The standard thermostat (180°) valve should start to open at a temperature of 177°F to 182°F, and should be fully open at a temperature of 202°F. If thermostat does not operate at specified temperatures it must be replaced as it cannot be adjusted.

#### g. Water Pump Repairs

The water pump cover is die cast aluminum into which the water pump bearing outer race is shrunk fit. For this reason the cover, shaft bearing, and hub are not replaceable.

#### h. Removal of Water Pump

1. Drain coolant into a clean container.
2. Loosen belt or belts, then remove fan blade, and pulley or pulleys from hub on water pump shaft. Remove belts.
3. Disconnect hose from water pump inlet and heater hose from nipple. Remove bolts, pump assembly, and gasket from timing chain cover.
4. Check pump shaft bearings for end play or roughness in operation. If bearings are not in serviceable condition, the assembly must be replaced.

#### i. Installation of Water Pump

1. Make sure the gasket surfaces on pump and timing chain covers

are clean. Install pump assembly with new gasket. Bolts with lock washers must be tightened uniformly.

2. Connect radiator hose to pump inlet and heater hose to nipple. Fill cooling system and check for leaks at pump and hose joints.
3. Install fan pulley or pulleys and fan blade, tighten attaching bolts securely. Install belts and adjust for proper tension.

### 63-2 INTAKE AND EXHAUST MANIFOLDS

#### a. Intake Manifold and Heat Control Valve

The V-8 engine utilizes a low-restriction, dual intake manifold.

It is bolted to the inner edges of both cylinder heads so that it connects with all inlet ports. Since the intake manifold is cast iron, as is the carburetor throttle body, the manifold incorporates a special exhaust heat passage to warm the throttle body. Fuel/air mixture distribution to each intake part is shown in Figure 60-108.

The manifold heat control valve, located on the left exhaust manifold, regulates the amount of exhaust gas passing through the intake manifold. A bi-metallic spring attached to the control valve shaft tends to gradually restrict the amount of exhaust gas warming the throttle body by slowly closing the valve. When engine operating temperature is reached, a small quantity of exhaust gas continues to warm the throttle body.

Intake manifold heat is necessary when operating the engine in cold temperatures. Better fuel mixture vaporization, with resulting improved combustion, is achieved.



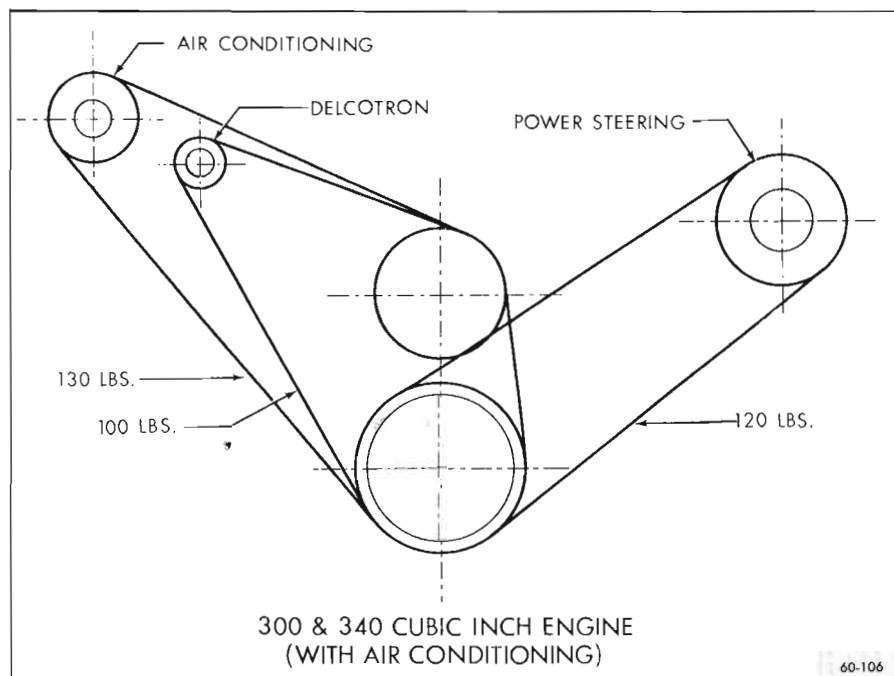

Figure 60-106—Engine Belt Tension Chart - Air Conditioned Cars

#### b. Intake Manifold Removal and Installation

The following points should be kept in mind whenever an operation involving removal and installation of the intake manifold is undertaken:

1. New intake manifold gaskets must be obtained whenever a manifold is removed.
2. When installing a manifold, start with the #1 and #2 bolts. See Figure 60-109. Gradually tighten both bolts until snug. Then continue with the rest of the bolts in the sequence illustrated in Figure 60-109.

#### c. Heat Control Valve Service

1. Every 6,000 miles, check the heat control valve shaft to be certain it is free.
2. If shaft is binding, turn it several times by hand to loosen it. Apply "Buick Heat Trap Lube" or equivalent to ends of shaft.

3. Check all anti-rattle and thermostat springs for correct installation. See Figure 60-110.

#### d. Exhaust Manifold

Each cylinder exhausts through an individual port into separate branches of the intake manifold. Each branch empties into a main branch which connects to the engine exhaust pipe on the left side and the heat control valve on the right side. The exhaust manifold attaches to the outer edges of the cylinder heads as shown in Figure 60-111. Lock plates are used to secure the exhaust manifold attaching bolts.

**CAUTION:** The locking plates must always be reinstalled when replacing the exhaust manifold. Since the exhaust manifold tends to expand and contract when engine is first started, a light torque of 10-15 lb. ft. is required to prevent the manifold from cracking. Therefore, the lock plates must be used to insure that the bolts cannot turn.

### 63-3 ENGINE MOUNTING, FLYWHEEL, AND ENGINE BALANCING

#### a. Removal of Front Mounts

1. Raise car and provide frame support at front of car.
2. Support weight of engine at forward edge of oil pan.
3. Remove mount to engine block bolts. Raise engine slightly and remove mount to mount bracket bolt and nut. Remove mount.

#### b. Installation of Front Mount

1. Install mount to engine block bolts and torque to 50-75 lb. ft.
2. Lower engine so mounts rest on frame cross member in normal manner. Install mount to bracket bolt and torque to 45-60 lb. ft.
3. Remove frame support and lower car.

#### c. Removal of Rear (Transmission) Mount

For details of engine and transmission mounts and transmission support installation refer to Figures 60-112 and 60-112a.

#### d. Removal and Replacement of Automatic Transmission Flywheel

1. Remove transmission (GROUP 74).
2. Remove six bolts attaching flywheel to crankshaft flange.
3. Inspect flywheel; if cracked at flywheel bolt holes, replace flywheel.
4. Inspect crankshaft flange and flywheel for burrs. Remove any burrs with a mill file.
5. Install flywheel. Bolt holes are unevenly spaced so all flywheel bolts can be installed with flywheel in correct position. Install

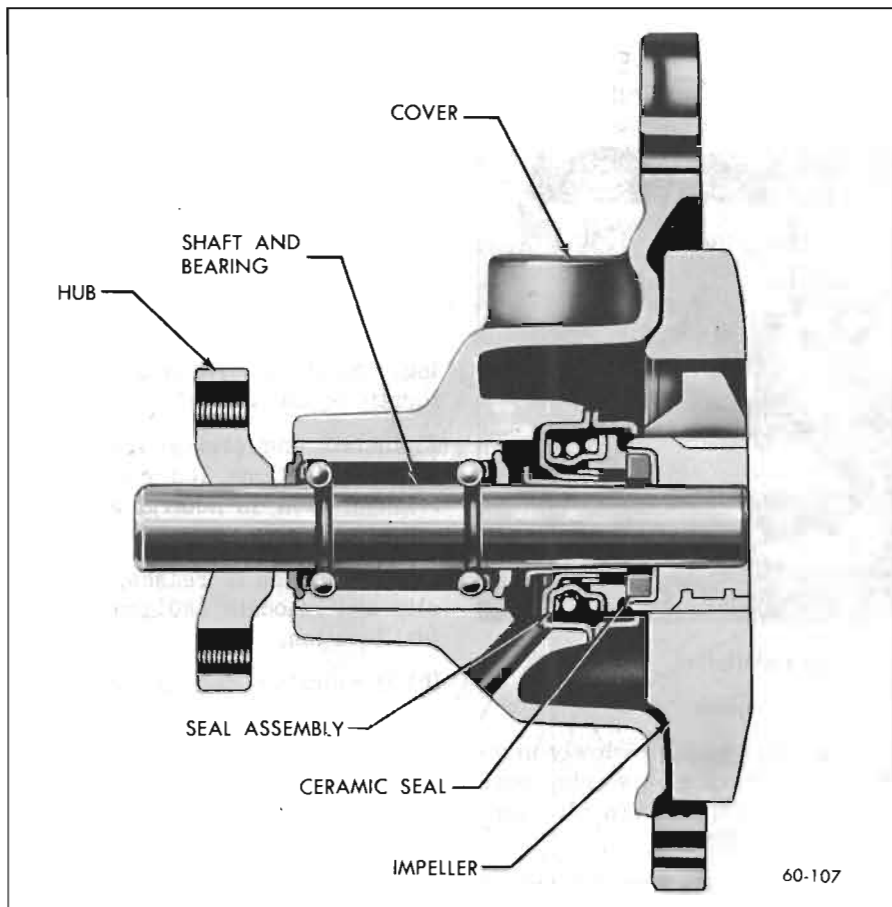

Figure 60-107—Water Pump Cross Section



Figure 60-110—Manifold Heat Control Valve

bolts and torque evenly to 50-65 lb. ft.

6. Mount dial indicator on engine block and check flywheel run-out at three attaching bosses. Run-out should not exceed .015".

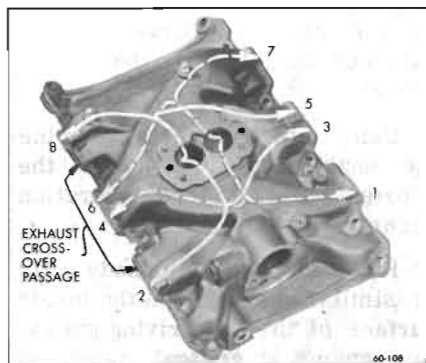

Figure 60-108—Intake Manifold Distribution

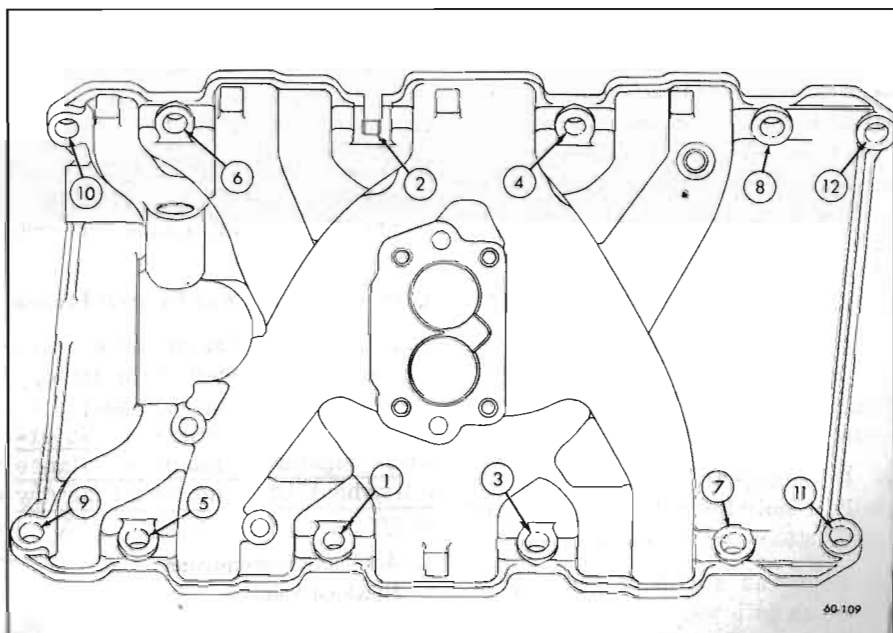

Figure 60-109—Intake Manifold Bolt Tightening Sequence



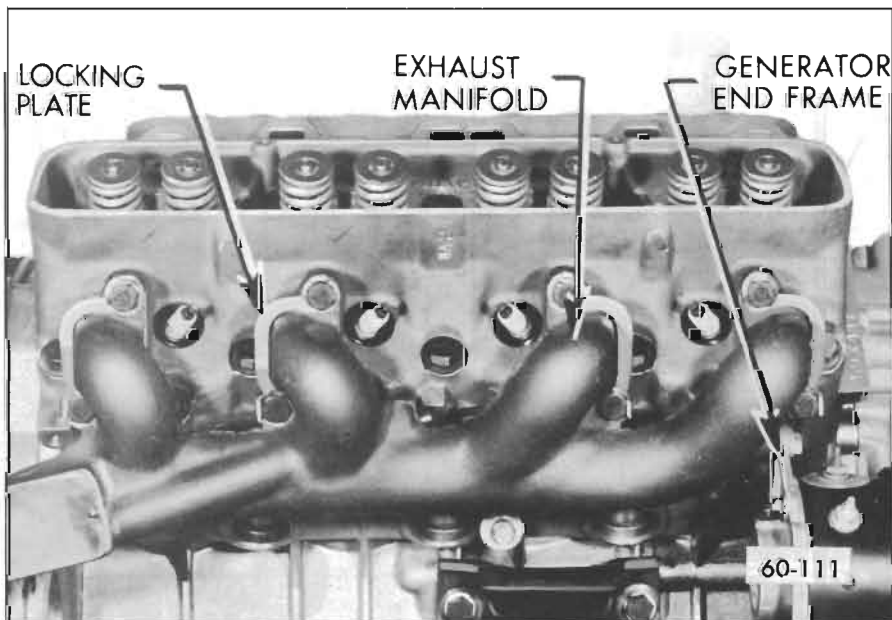

Figure 60-111—Exhaust Manifold Installation

**NOTE:** The crankshaft end play must be held in one direction during this check.

7. If run-out exceeds .015", attempt to correct by tapping high side with mallet. If this does not correct, remove flywheel and check for burrs between flywheel and crankshaft mounting flange.

#### e. Replacement of Flywheel or Ring Gear on Manual Transmission Engine

1. Remove transmission and clutch assembly, being certain to mark clutch cover and flywheel so clutch may be reinstalled in original position.

2. Remove flywheel. Flywheel is located in a predetermined location on crankshaft by attaching bolts, which are unevenly spaced.

3. If ring gear is to be replaced, drill a hole between two teeth and split gear with a cold chisel.

4. Heat and shrink a new gear in place as follows:

a. Polish several spots on ring with emery cloth.

b. Use a hot plate or slowly moving torch to heat the ring until the polished spots turn blue (approximately 600°F.)

**CAUTION:** Heating the ring in excess of 800°F will destroy the heat treatment.

c. Quickly place ring in position against shoulder of flywheel with chamfered inner edge of ring gear toward flywheel shoulder. Allow ring to cool slowly until it contracts and is firmly held in place.

5. Make certain the flywheel and crankshaft flange are free from burrs that would cause run-out. Install flywheel.

#### f. Manual Transmission Flywheel Balance

All manual transmission flywheels are balanced at the factory by drilling holes at various points on the flywheel surface. No attempt should be made to balance a flywheel after the initial factory balance.

#### g. Automatic Transmission Flywheel Balance

Clips are available from the Parts Department under Group 0.666 that will serve as balance

weights for automatic transmission flywheels. These clips are secured by their clamping pressure and a series of indentations stamped into the flywheels. See Figure 60-113 for clip installation locations.

If a flywheel is found to be out of balance, it can be corrected in the following manner.

1. Remove lower flywheel housing. Mark the flywheel at four locations, 90° apart.

2. Install one clip at one of the marked locations. Run engine with transmission in neutral and note vibration.

(a) If vibration increases, remove clip and relocate 180° from original location.

(b) If vibration decreases, install another clip next to the original.

(c) If no change is noted, move clip 90° and recheck.

3. Continue this procedure until a reduction in vibration is noted. Fine adjustments can be made by moving the clips, by small increments, to different locations.

**CAUTION:** Be certain that the tangs on the clip are setting in the stamped grooves on the flywheel. Otherwise, the clip(s) may shift when the flywheel is turned at high speeds.

#### h. Harmonic Balancer

If a harmonic balancer is suspected of being a cause of vibration, it can be checked and/or balanced by following the outline below:

a. Using a tachometer, determine the engine speed at which the greatest amount of vibration occurs.

b. Place an amount of body putty or similar material on the inside surface of the fan driving pulley. Run engine at critical speed and note vibration.

c. Repeat Step 2 above using

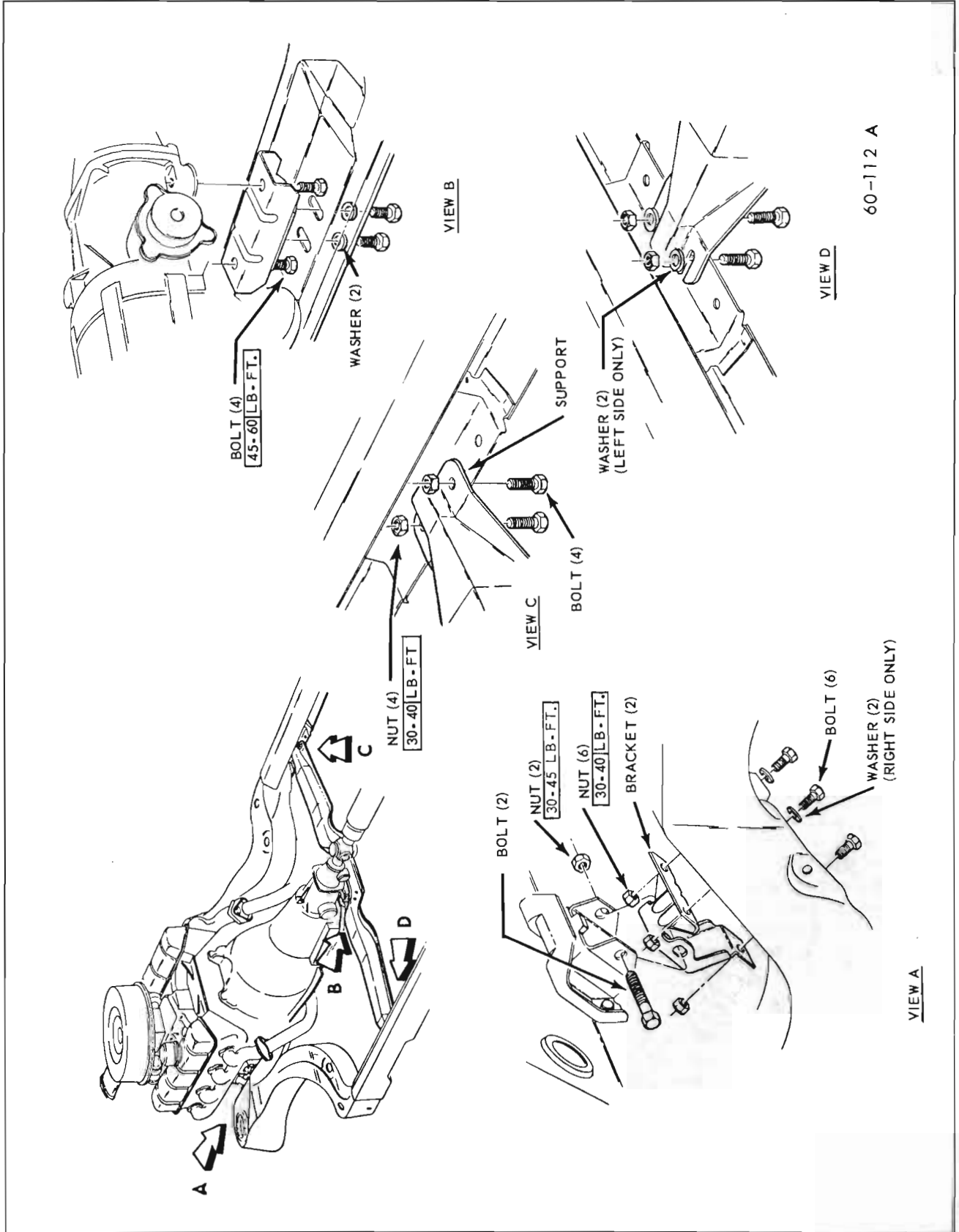
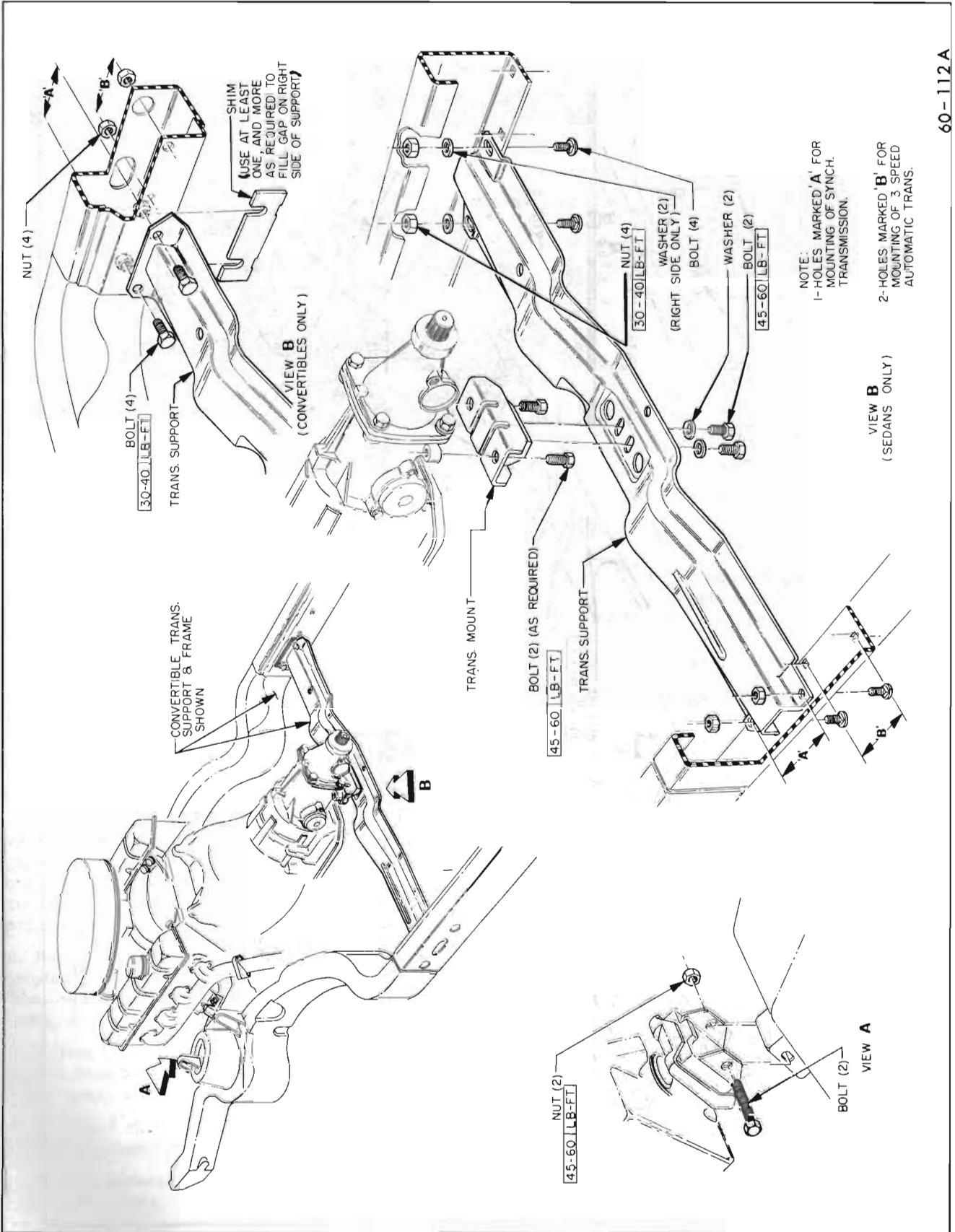

Figure 60-112—Engine and Transmission Mounting 43 and 44000 (Less 44000 Gran Sport) Series



60-112A

Figure 60-112a—Engine and Transmission Mounting 45000 Series

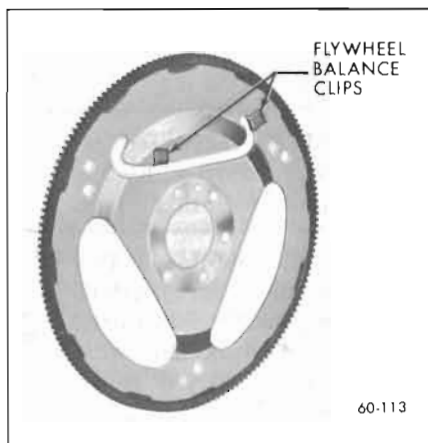

Figure 60-113—Automatic Transmission Flywheel Balance Clip Locations

varying amounts of putty at different locations until the vibration is diminished to a minimum.

d. When point of minimum vibration is found, mark the nearest hole drilled in the balancer at that point.

e. Cut a piece of 7/16" drill rod approximately 1/2" long. Using a

USE CHISEL TO UPSET SMALL AMOUNT OF MATERIAL THIS WILL PROVIDE A PRESS FIT

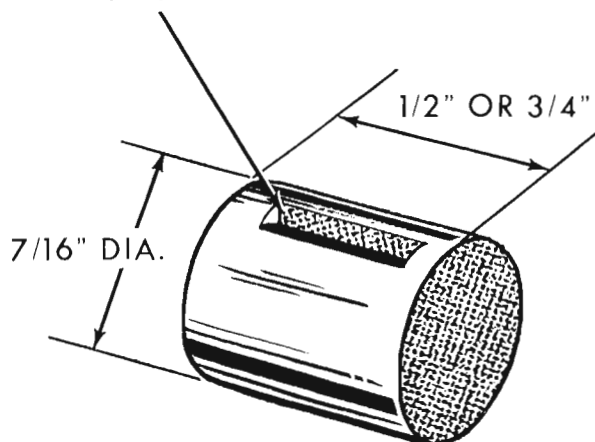

Figure 60-114—Harmonic Balancer - Balance Weight Details

chisel, upset a small amount of material on the side of the piece of drill rod. See Figure 60-114.

f. Install drill rod into hole

marked in Step 4.

g. Additional weight should be added (if necessary) in adjoining holes.

## DIVISION IV TROUBLE DIAGNOSIS

### 63-9 EXCESSIVE OIL CONSUMPTION

POSSIBLE CAUSE	CORRECTION
External Oil Leaks at: Rocker Arm Covers Timing Chain Cover Oil Pan and Gasket Around Starter Bolts Between Oil Pan and Flywheel Housing	Tighten attaching bolts. If leaks persist, remove cover (or pan), check sealing surfaces for burrs or scoring, replace gasket, and seal attaching bolts with Permatex #2 or equivalent.
Improper Reading of Dip Stick	Car may not be level when taking reading. Insufficient oil "drain-back" time allowed after stopping engine (one minute must be allowed). Dip stick may not be completely pushed down against stop. Dip stick may be bent.
Oil Viscosity too Light	Use recommended S.A.E. viscosity for prevailing temperatures.

## 63-9 EXCESSIVE OIL CONSUMPTION (Cont'd.)

POSSIBLE CAUSE	CORRECTION
Continuous High Speed Driving	At speeds above 60 MPH, increased oil consumption can be expected with any engine. Inform customer of this fact.
High Speed Driving following Normal Slow Speed City Driving	When principal use of automobile is city driving, crankcase dilution from condensation occurs. High speed and temperatures will remove water, resulting in what appears to be rapid lowering of oil level. Inform customer of this fact.
Valve Guides Worn—Excessive Clearance	Ream out guides and install service valves with oversize stems. Refer to Par. 61-1.
Piston Rings not "broken in"	Allow engine to accumulate at least 4,000 miles before attempting any engine disassembly to correct for oil consumption.

## 63-10 NOISY VALVES AND LIFTERS

## a. Noisy Valve Train

The noise level of the valve mechanism cannot be properly judged where the engine is below operating temperature when the hood is raised, or when the valve rocker arm covers are removed.

Before attempting to judge valve noise level, the engine must be thoroughly warmed up (at least 20 minutes of operation at 1200 to 1500 RPM) to stabilize oil and coolant temperatures and bring all engine parts to a normal state of expansion. When the engine is warmed up, listen for engine noise while sitting in the drivers seat with the hood closed. Run the engine at idle and at various higher speeds. It is advisable to observe the noise level in several engines that have been properly broken in, in order to develop good judgment for checking the noise level in any given engine.

If the preceding check indicates the valve mechanism is abnormally noisy, remove the rocker arm covers so that the various

conditions that cause noise may be checked. A piece of heater hose of convenient length may be used to pick out the particular valves or valve linkages that are causing abnormal noise. With the engine running at a speed where the noise is pronounced, hold one end of hose to an ear and hold other end about 1/2" from point of contact between rocker arm and valve stem. Mark or record the noisy valves for investigation of following causes.

(1) Excessive Oil In Crankcase. Crankcase oil level high enough to allow the crankcase to churn the oil will cause air bubbles in the lubricating system. Air bubbles entering the hydraulic lifters will cause erratic operation resulting in excessive lash in the valve linkage. Locate and correct cause of high oil level, then run engine long enough to expel air from system.

(2) Sticking, Warped or Eccentric Valves, Worn Guides. Sticking valves will cause irregular engine operation or missing on a low speed pull and will usually cause intermittent noise.

Pour penetrating oil over the

valve spring cap and allow it to drain down the valve stem. Apply pressure to the one side of the valve spring and then the other, and then rotate the valve spring about 1/2 turn. If these operations affect the valve noise, it may be assumed that valves should be reconditioned.

(3) Worn or scored parts in the valve train. Inspect rocker arms, push rod ends for scoring. Check push rods for bends, valve lifters and camshaft surfaces for scoring. Replace faulty parts.

(4) Valves and seats cut down excessively. Noisy and improper valve action will result if a valve and its seat have been refinished enough to raise the end of the valve stem approximately .050" above normal position. In this case it will be necessary to grind off the end of the valve stem or replace parts. The normal height of the valve stem above the valve spring seat is 1.925 inches.

(5) Faulty Hydraulic Valve Lifters. If the preceding suggestions do not reveal the cause of noisy valve action, check operation of valve lifters as described in paragraph 61-1, subparagraph c.

### b. Noisy Valve Lifters

When checking hydraulic valve lifters, remember that grit, sludge, varnish or other foreign matter will seriously affect operation of these lifters. If any foreign substance is found in the lifters or engine where it may be circulated by the lubrication system, a thorough cleaning job must be done to avoid a repetition of lifter trouble.

To help prevent lifter trouble, the engine oil and oil filter must be changed as recommended in Group 00. The engine oil must be heavy-duty type (MS marked on container) and must also conform to General Motors Specification 4745-M to avoid detrimental formation of sludge and varnish. A car owner should be specifically advised of these requirements when the car is delivered. Faulty valve lifter operation usually appears under one of the following conditions:

(1) Rapping noise only when engine is started. When engine is stopped, any lifter on a camshaft lobe is under pressure of the valve spring; therefore, leak down or escape of oil from the lower chamber can occur. When the engine is started a few seconds may be required to fill the lifter, particularly in cold weather. If noise occurs only occasionally, it may be considered normal requiring no correction. If noise occurs daily, however, check for (a) oil too heavy for prevailing temperatures (b) excessive varnish in lifter.

(2) Intermittent Rapping Noise. An intermittent rapping noise that appears and disappears every few seconds indicates leakage at check ball seat due to foreign particles, varnish, or defective surface of check ball or seat. Recondition, clean, and/or replace lifters as necessary.

(3) Noise on idle and low speed. If one or more valve lifters are

noisy on idle and up to approximately 25 MPH but quiet at higher speeds, it indicates excessive leakdown rate or faulty check ball seat on plunger. With engine idling, lifters with excessive leakdown rate may be spotted by pressing down on each rocker arm above the push rod with equal pressure. Recondition or replace noisy lifters.

(4) Generally noisy at all speeds. Check for high oil level in crankcase. See subparagraph a (1) above. With engine idling, strike each rocker arm above push rod several sharp blows with a mallet; if noise disappears, it indicates that foreign material was keeping check ball from seating. Stop engine and place lifters on camshaft base circle. If there is lash clearance in any valve linkage, it indicates a stuck lifter plunger, worn lifter body lower end, or worn camshaft lobe.

(5) Loud noise at normal operating temperature only. If a lifter develops a loud noise when engine is at normal operating temperature, but is quiet when engine is below normal temperature, it indicates an excessively fast leakdown rate or scored lifter plunger. Recondition or replace lifter.

## 63-11 COOLING SYSTEM TROUBLE

### a. Cooling System Trouble Diagnosis

If the radiator is filled too full when cold, expansion when hot will overflow the radiator and coolant will be lost through the overflow pipe. Adding unnecessary water will weaken the anti-freeze solution and raise the temperature at which freezing may occur.

If the cooling system requires frequent addition of water in order to maintain the proper level in the radiator, check all units and connections in the cooling system

for evidence of leakage. Inspection should be made with cooling system cold. Small leaks which may show dampness or dripping can easily escape detection when the engine is hot, due to the rapid evaporation of coolant. Tell-tale stains of grayish white or rusty color, or dye stains from anti-freeze, at joints in cooling system are almost always sure signs of small leaks even though there appears to be no dampness.

Air or gas entrained in the cooling system may raise the level in radiator and cause loss of coolant through the overflow pipe. Air may be drawn into the cooling system through leakage at the water pump seal. Gas may be forced into the cooling system through leakage at the cylinder head gasket even though the leakage is not sufficient to allow water to enter the combustion chamber. The following quick check for air leaks on suction side of pump or gas leakage from engine may be made with a piece of rubber tubing and a glass bottle containing water.

1. With cooling system cold, add water to bring coolant to proper level.

2. Block open the radiator cap pressure valve, or use a plain cap, and be sure radiator cap is on tight. Attach a suitable length of rubber hose to overflow pipe.

3. Run engine in neutral at a safe high speed until the engine reaches a constant operating temperature.

4. Without changing engine speed, put the free end of rubber hose into a bottle of water, avoiding kinks or low bends that might block the flow of air.

5. Watch for air bubbles in water bottle. A continuous flow of bubbles indicates that air is being sucked into the cooling system, or exhaust gas is leaking into the cooling system past the cylinder head gasket.



**b. Cooling System Overheating**

It must be remembered that the Buick pressure system operates at higher temperatures than systems operating at atmospheric pressure. Depending on the pressure in cooling system, the temperature of permanent type anti-freeze may go considerably

above 212°F without danger of boiling.

In cases of actual overheating the following conditions should be checked:

1. Excessive water loss.
2. Slipping or broken fan belt.
3. Radiator thermostat stuck,

radiator air passages clogged, restriction in radiator core, hoses, or water jacket passages.

4. Improper ignition timing.
5. Shortage of engine oil or improper lubrication due to internal conditions.
6. Dragging brakes.