

# SECTION C

## 45-46000 MANUAL BRAKES

## 48-49000 HYDRAULIC MASTER CYLINDER

## 45-46-48-49000 HYDRAULIC WHEEL CYLINDER, BRAKE PIPES AND HOSES, PARKING BRAKE CABLES

### CONTENTS

Division	Paragraph	Subject	Page
I		SPECIFICATIONS AND ADJUSTMENTS:	
	50-9	Brake Specifications . . . . .	50-36
	50-10	Brake Adjustment . . . . .	50-37
	50-11	Parking Brake Adjustment. . . . .	50-38
II		DESCRIPTION AND OPERATION:	
	50-12	Description of Brake Mechanism . . . . .	50-38
	50-13	Operation of Hydraulic Service Brakes . . . . .	50-47
III		SERVICE PROCEDURES:	
	51-5	Replace or Reline Brake Shoes . . . . .	50-49
	51-6	Repair Brake Linings . . . . .	50-51
	51-7	Inspecting and Reconditioning Brake Drums . . . . .	50-52
	51-8	Brake Wheel Cylinder Overhaul . . . . .	50-53
	55-2	Brake Master Cylinder Overhaul . . . . .	50-53
	56-3	Replacing Brake Pipes. . . . .	50-54
56-4	Filling, Bleeding and Flushing Brake Hydraulic System . . . . .	50-55	
IV		TROUBLE DIAGNOSIS:	
	59-4	Inspecting and Testing Brakes. . . . .	50-56
	59-5	Brake Trouble Indications. . . . .	50-57

## DIVISION I

### SPECIFICATIONS AND ADJUSTMENTS

#### 50-9 BRAKE SPECIFICATIONS

##### a. Tightening Specifications

Use a reliable torque wrench to tighten the parts listed, to insure proper tightness without straining or distorting parts. These specifications are for clean and lightly lubricated threads only; dry or dirty threads produce increased friction which prevents accurate measurement of tightness.

	Name	Thread Size	Torque Lbs. Ft.
Nut	Brake Pedal Pivot Shaft to Mounting Bracket (Automatic Transmission) . .	5/16-24	10-15
Screw	Wheel Cylinder to Brake Backing Plate . . . . .	5/16-18	10-15
Nut	Brake Cylinder and Pedal Mounting Bracket to Dash . . . . .	3/8-16	20-28
Bolt & Nut	Brake Assembly and Steering Arm to Knuckle . . . . .	1/2-13	90-120
Nut	Rear Brake Assembly to Axle Housing . . . . .	3/8-16	40-55
Bolt	Brake Assembly through Anchor Pin to Knuckle . . . . .	9/16-18	130-150
Nut	Rear Wheel and Brake Drum to Axle Shaft . . . . .	1/2-20	65-85
Screw	Reinforcement to Dash . . . . .	5/16	10-15

## b. General Specifications

Items	
Operating Mechanism, Service Brakes . . . . .	Hydraulic
Parking Brakes . . . . .	Lever and Cables
Operation of Service Brakes Independent of Parking Brakes . . . . .	Yes
Wheels Braked, Service . . . . .	Front and Rear
Parking . . . . .	Rear Only
Approx. % of Total Braking Power on—Front Wheel Brakes . . . . .	56
Rear Wheel Brakes . . . . .	44
Brake Pedal Height Adjustment, Standard and Power . . . . .	None
Static Pressure in Hydraulic System when Brakes are Released . . . . .	.8 to 16 lbs.
Number of Brake Shoes at Each Wheel . . . . .	2
Brake Type . . . . .	Self Energizing-Servo
Brake Shoe Lining Type . . . . .	1 pc. Molded-Riveted
Front Shoe Lining Width x Minimum Thickness . . . . .	2.25" x .220" Primary: 2.25" x .254" Secondary
Rear Shoe Lining Width x Minimum Thickness . . . . .	2.00" x .220" Primary: 2.00" x .254" Secondary
Front Brake Drum, All Series Except 45000 . . . . .	Finned Aluminum with C.I. Liner
Front Brake Drum, 45000 . . . . .	Finned Cast Iron
Master Cylinder Piston Dia., Standard and Power . . . . .	1"
Wheel Cylinder Size, Front . . . . .	1-1/8"
Rear . . . . .	1"
Approved Hydraulic Brake Fluid . . . . .	Delco Super 11 Extra Heavy Duty or equiv.
Fluid Level, Below Lip of Reservoir Opening . . . . .	1/8"
Shoe Adjusting Screw Setting, from Point where Wheels can just be turned by hand . . . . .	Back Off 30 Notches
Brake Drum Inside Diameter, New . . . . .	11.997" to 12.022"
Brake Drum Rebore, Max. Allowable Inside Diameter . . . . .	12.080"
Max. Allowable Taper, Before Rebore . . . . .	.005"
Max. Allowable Out-of-Round, Before Rebore . . . . .	.010"
Max. Allowable Out-of-Balance of Drum . . . . .	3 oz. in.
Max. Allowable Space Between Lining and Shoe Rim after Riveting . . . . .	.005"

## 50-10 BRAKE ADJUSTMENT

### a. Preliminary Checks

1. Depress brake pedal firmly. If pedal travels to within 2-1/4" of toeboard on manual brake equipped cars or 1-1/2" of toeboard on power brake equipped cars, brake shoes require adjustment or relining. However, if pedal has a spongy feel, brake system needs bleeding.

2. Remove one front wheel with hub and drum assembly. Inspect brake lining. If lining is worn nearly to rivets, reline brakes (par. 51-5).

3. Check fluid level in master cylinder reservoir and add fluid if necessary (par. 56-4).

4. Fully release parking brake lever and place transmission in neutral.

5. Pull on ends of both rear brake cable a number of times to make sure that cables operate rear brake shoes freely and do not bind. Check for free movement of cable in brake cable equalizer. Replace cable assembly if return spring is weak or broken.

### b. Pedal Height and Stop Light Switch Adjustment

**NOTE:** Brake pedal height cannot be adjusted in either manual or power brake cars. In both manual and power brake cylinders, non-adjustable push rods connect directly to the brake pedals. Therefore, brake pedal height depends entirely on a stop in the master cylinder, which is also non-adjustable. No external brake pedal return spring is used, so pedal return depends entirely on a spring within the cylinder.

Make certain that the brake pedal returns completely when released slowly. If the pedal does not return freely, check all pivot points for binding or lack of lubrication. With pedal in fully released position, the stop light switch plunger should be fully depressed against an operating plate on the pedal shank. Adjust switch by turning in or out as necessary. See Figures 50-45 and 50-46.

### c. Adjustment at Wheels

1. Remove adjusting hole cover from brake backing plate. Install J-21281 through adjusting hole to move actuator off adjusting screw. Use J-6166 to turn brake adjusting screw, expand brake shoes at each wheel until the wheel can just be turned by hand. Moving protruding end of tool downward expands the shoes. See Figure 50-36. The drag should be equal at all wheels.

2. Back off brake adjusting screw at each wheel 30 notches. If shoes still drag lightly on drum, back off adjusting screw one or two additional notches.

**NOTE:** Brakes should be free of drag when screw has been backed off approximately 12 notches. Heavy drag at this point indicates tight parking brake cables.

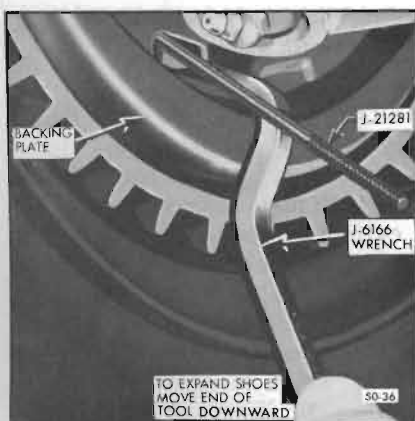

Figure 50-36—Adjusting Right Front Brake Shoes

3. Install adjusting hole cover in backing plate when adjustment is completed.

4. Check parking brake adjustment as described in paragraph 50-10.

5. Road test car for service and parking brake performance (Division IV).

### 50-11 PARKING BRAKE ADJUSTMENT

Adjustment of parking brake cable is necessary whenever the rear brake cables have been disconnected or when cables have been stretched through extended use. Need for parking brake adjustment is indicated if the service brake operates with good reserve, but the parking brake pedal can be depressed more than eight ratchet clicks under heavy foot pressure.

After making certain that service brakes are in good adjustment, adjust parking brake mechanism as follows:

1. Depress parking brake pedal exactly three ratchet clicks.

2. Loosen jam nut located at rear of equalizer adjusting nut. See Figures 50-39 and 50-41. Then tighten adjusting nut until rear wheels can just be turned rearward using two hands but are locked when forward rotation is attempted.

3. Release parking brake ratchet one click; at this two-click engagement, the rear wheels should rotate forward with a light drag and rearward freely.

4. Release mechanism one more ratchet click. At a one-click engagement, as well as with mechanism totally disengaged, rear wheels should turn freely in either direction.

**CAUTION:** It is very important that parking brake cables are not adjusted too tightly to

cause brake drag. With automatic brake adjusters, a tight cable causes brake drag and also positions the secondary brake shoe, hence the adjuster lever, so that it continues to adjust to compensate for wear caused by the drag. The result is a cycle of wear and adjustment that can wear out linings very rapidly.

## DIVISION II

### DESCRIPTION AND OPERATION

#### 50-12 DESCRIPTION OF BRAKE MECHANISM

The brake mechanism includes a brake drum and a brake assembly at each wheel and two separate and independent control systems for applying the brakes -- (1) Parking brake control system (2) Service brake control system with self-adjusting mechanism.

#### a. Wheel Brake Assemblies

All rear brake drums consist of a cast iron rim fused to a pressed steel disc. The cast iron rim provides an ideal braking surface and increases brake lining life. External ribs and fins aid in dissipation of heat.

Front brake drums on the 46-48-49000 Series are cast aluminum alloy with a cast iron liner. The aluminum section has ribs and fins for heat dissipation while the cast iron liner provides the best braking surface. The lighter 45000 Series has finned cast iron drums.

The brake assembly at each wheel uses a primary (front) and secondary (rear) brake shoe of welded steel construction. One-piece molded linings are attached to the brake shoes by rivets. The primary shoe lining is shorter than the secondary shoe lining and is of different composition; therefore, the two shoes are not interchangeable. See Figure 50-37.

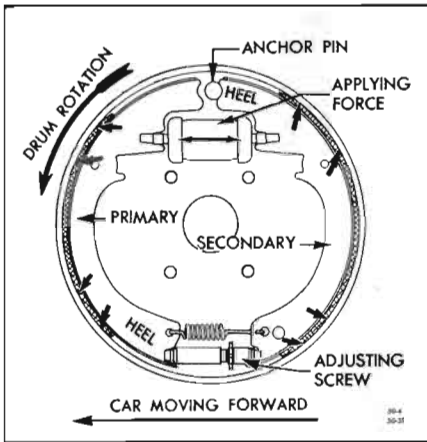

Figure 50-37—Brake Shoe Action

Each brake shoe is held against the backing plate by a hold-down spring, pin and cup which allow free movement of the shoe. The notched upper end of each shoe is held against the single anchor pin by a heavy coil spring. An adjusting screw and spring connects the lower ends of both shoes together and provides adjustment for clearance with the brake drum.

A hydraulic wheel cylinder mounted on the backing plate between the upper ends of the brake shoes forces the shoes against the brake drum when the service brakes are applied. On rear wheels only, a lever mounted on each secondary shoe and connected to the primary shoe by a strut is used for applying the shoes when used as parking brakes. See Figure 50-38.

When the brake shoes contact the rotating drum in either direction of car travel, they move with the drum until the rearward shoe is stopped by the anchor pin and the forward shoe is stopped by the rearward shoe through the connecting adjusting screw. Frictional force between drum and shoe lining tries to rotate each shoe outward around its anchor point, but drum itself prevents this rotation; consequently, the shoes are forced more strongly against the drum than the applying

force is pushing them. See Figure 50-37. It is also evident that the force applied by the drum to the forward shoe is imparted to the rearward shoe through the connecting adjusting screw.

Utilization of the frictional force to increase the pressure of shoes against the drum is called self-energizing action. Utilization of force in one shoe to apply the opposite shoe is called servo action. The self-energizing servo action of Buick brakes provides powerful braking action with relatively light pedal pressure.

### b. Parking Brake Control System

The parking brake control system, which applies only the rear wheel brakes, uses a foot-operated lever, conduit enclosed cables, and brake shoe levers and struts. By means of an equalizer, the front parking brake cable is connected to the forward portion of a center cable. See Figures 50-39 and 50-41. This center cable is routed rearward from the equalizer through retaining guides which attach to right and left side frame rails. The center cable attaches at either end to a rear cable assembly. Each rear cable connects to the free lower end of a brake shoe lever. These levers (one in each rear brake shoe assembly) pivot on the secondary shoes. Struts are mounted between the brake shoe levers and the primary shoes. See Figure 50-49.

When the foot-operated lever is depressed, the cables apply an equal pull to each brake shoe lever. The levers and struts force all rear brake shoes into firm contact with brake drums. A ratchet mechanism on the pedal-lever assembly automatically locks the control system in applied position. The brakes are released by pulling on the release knob. A warning signal, which is

standard on 48-49000 Series and optional on 45-46000 Series, will show a red light on instrument panel if the car is operated with the parking brakes applied.

### c. Service Brake Control System Standard Brakes

**NOTE:** See Sections 50-D and 50-E for power brakes.

The regular foot-powered service brake control system is a pedal operated hydraulic system which applies the brakes at all four wheels with equalizer pressure.

The hydraulic system consists of one master cylinder connected by pipes and flexible hoses to a wheel cylinder mounted between the brake shoes at each wheel. The master cylinder, pipes, hoses and four wheel cylinders are filled with brake fluid.

A 1/4" O.D. pipe connects the master cylinder assembly to a distributor located on the left frame rail. A 3/16" O.D. brake pipe extends rearward from the distributor to a hose located near center of spring cross member on the 45-46-48000 Series. On the 49000 Series, the 3/16" O.D. brake pipe extends along the left frame rail to a point just ahead of the rear axle assembly where a

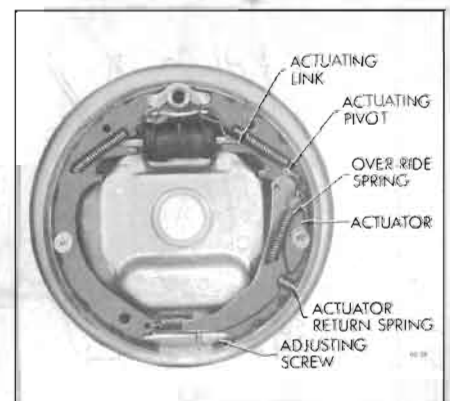
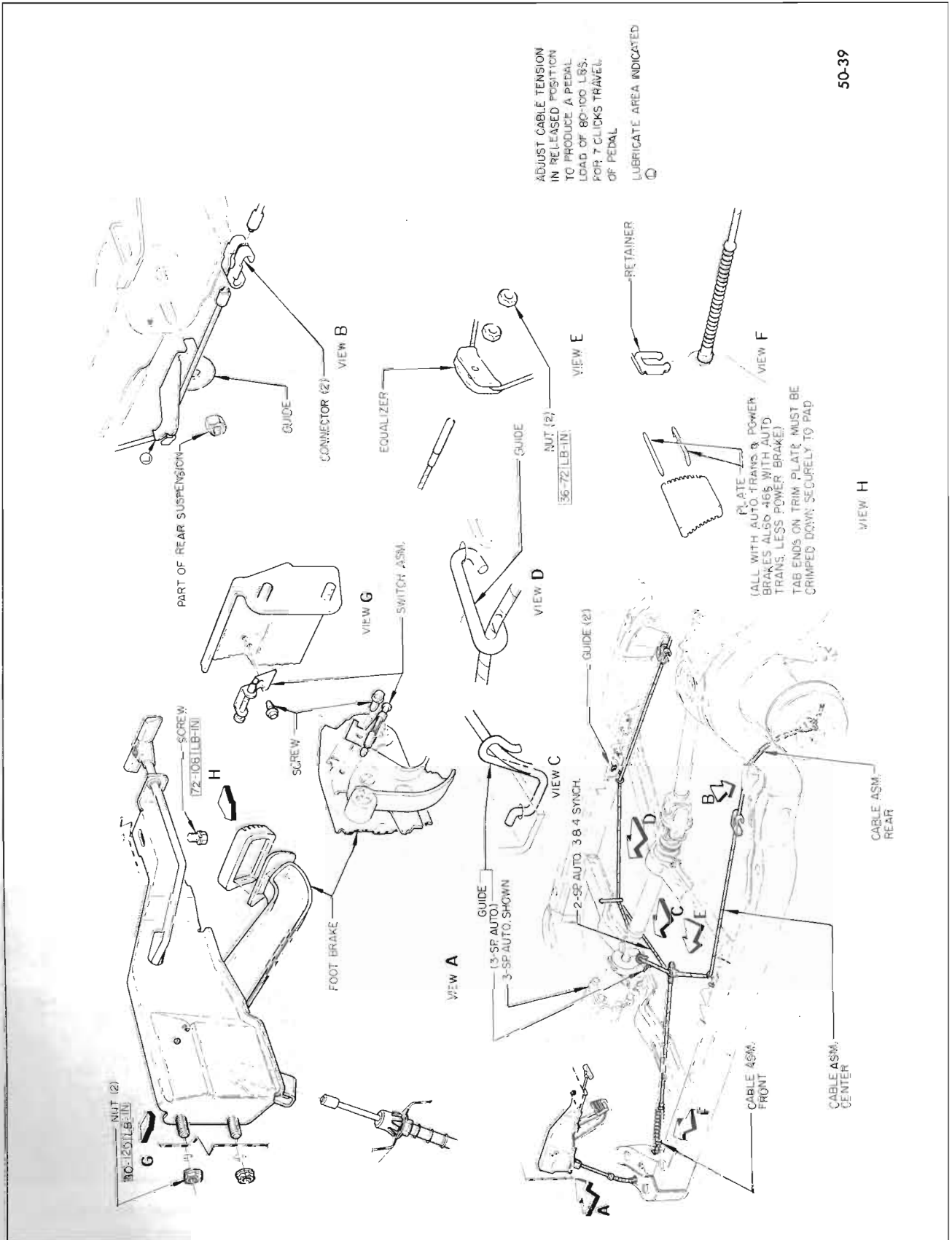

Figure 50-38—Left Front Brake Self-Adjuster Assembly



50-39

Figure 50-39 45-46-48000 Parking Brake Mechanism

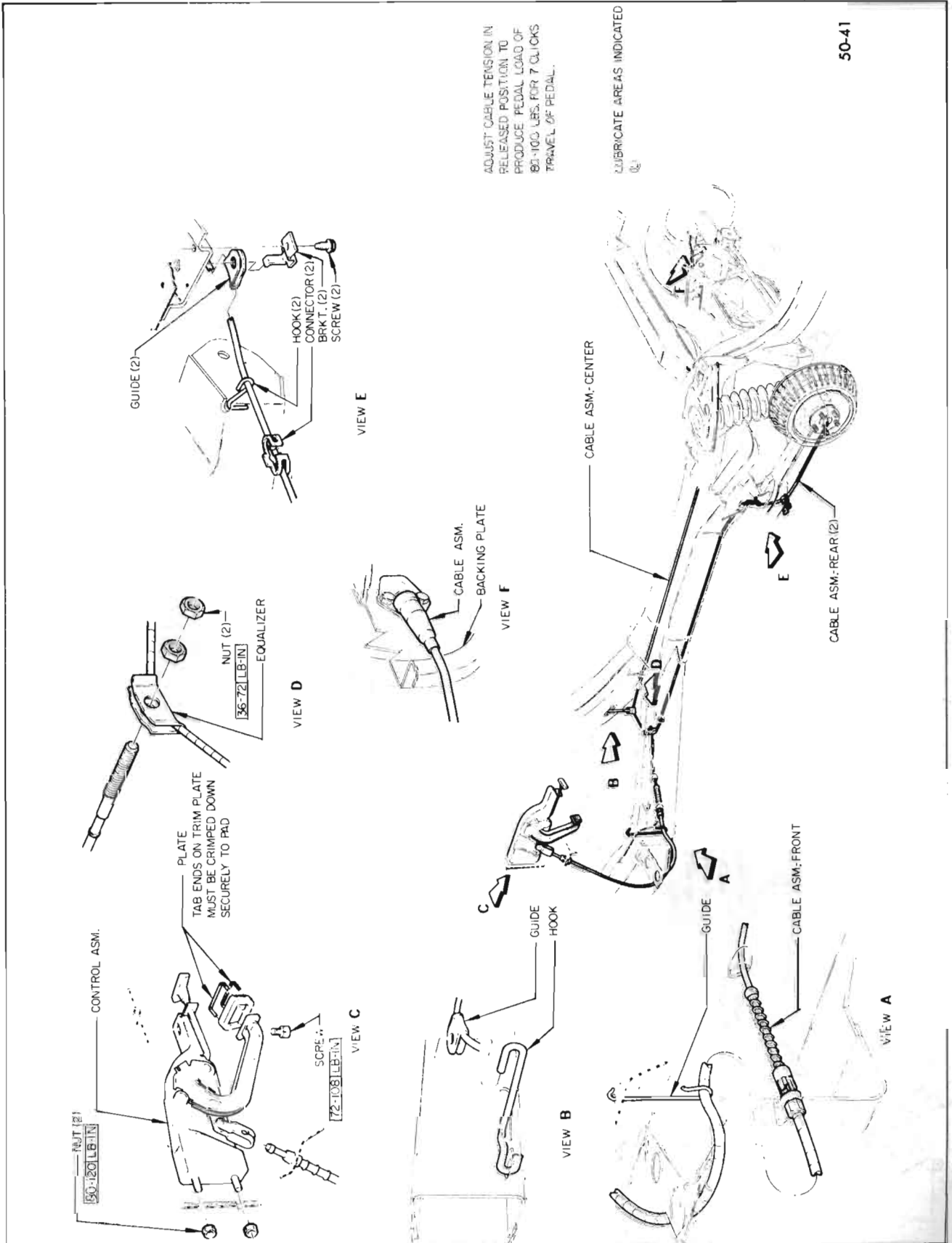
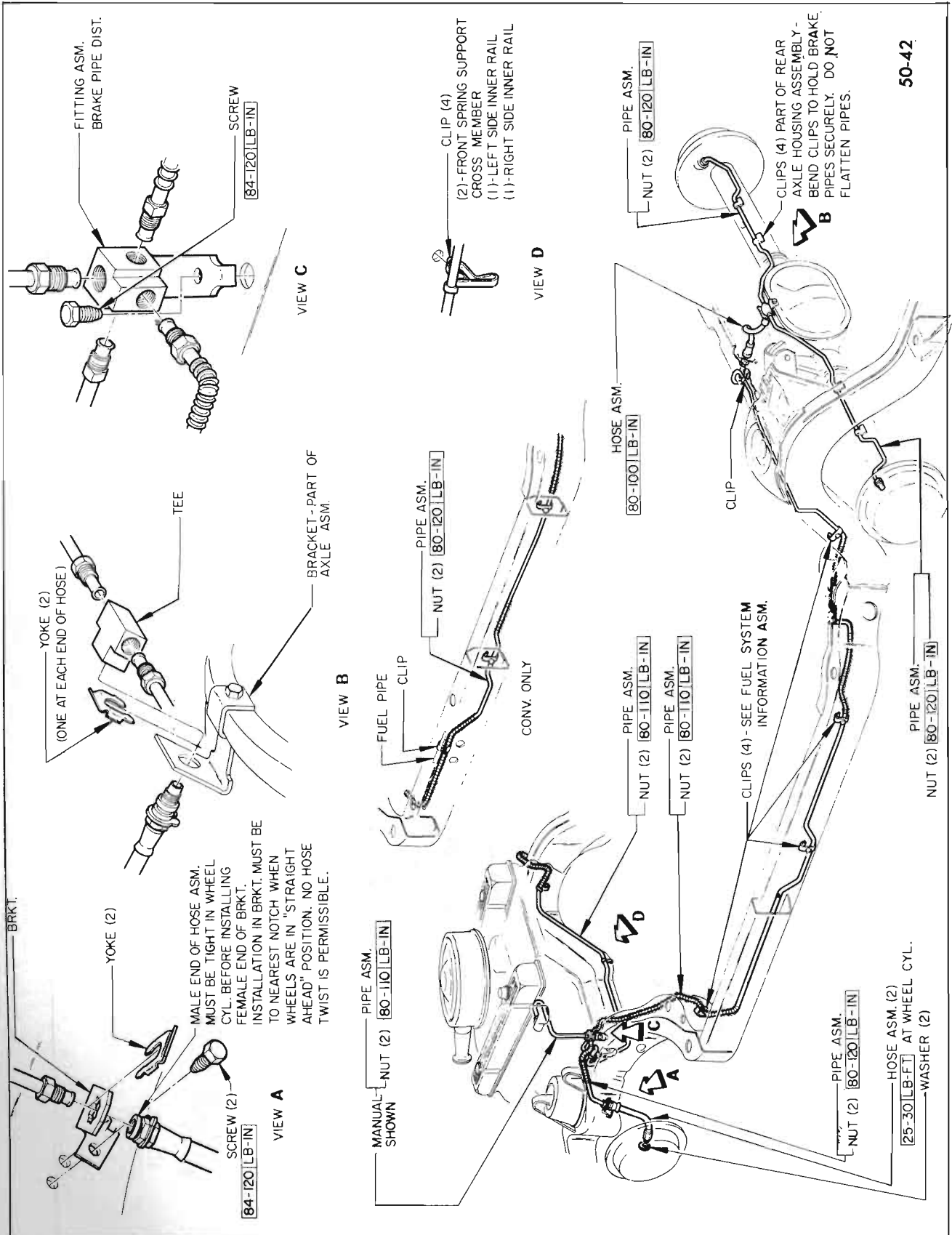

Figure 50-41 49000 Parking Brake Mechanism



50-42

Figure 50-42 45000 Service Brake Control System







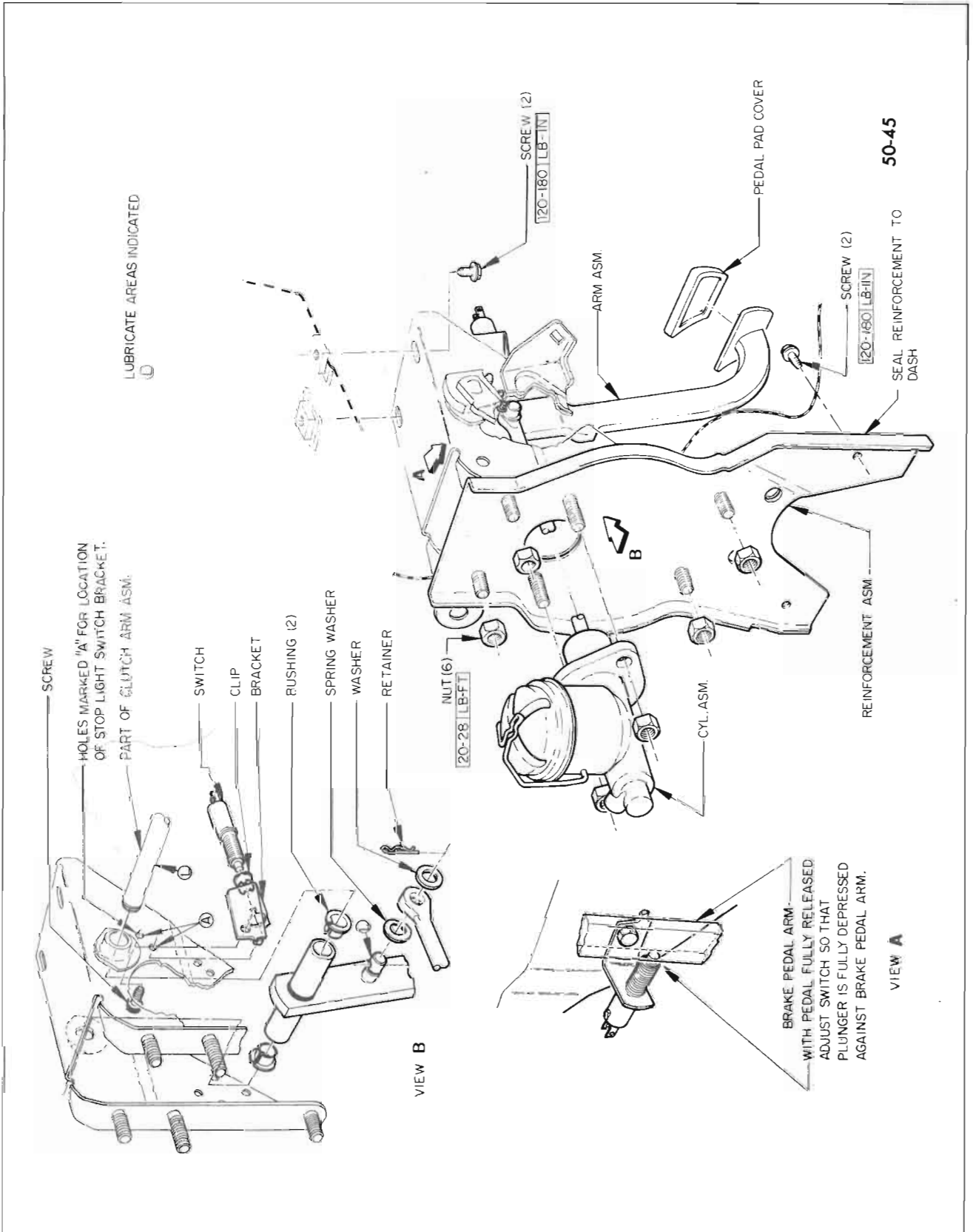
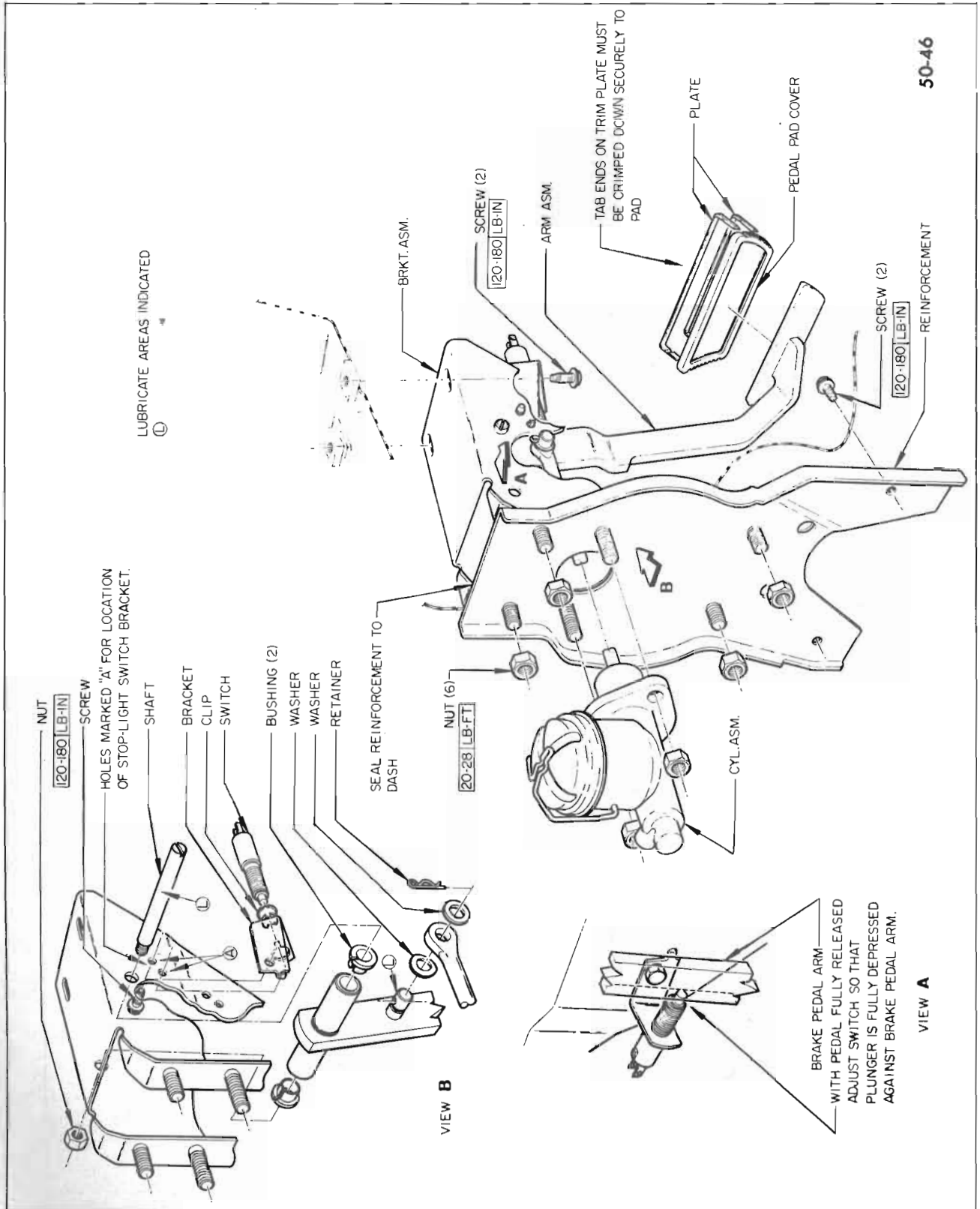

Figure 50-45 45-46000 Brake Pedal and Standard Master Cylinder (Manual Trans)



50-46

Figure 50-46 45-46000 Brake Pedal and Standard Master Cylinder (Auto Trans)

hose connects to the pipe. This hose is connected to a tee located on the left rear axle tube next to the carrier housing. Two pipes lead off from the tee, one to the left rear wheel cylinder and the other to the right rear wheel cylinder. See Figures 50-42, 50-43 and 50-44.

The brake pedal is suspended from a pivot shaft in the pedal bracket. The master cylinder push rod eye attaches to a pin on the shank of the pedal. The overall mechanical advantage in the standard brake linkage is 6 to 1. See Figures 50-45 and 50-46.

The pivot shaft in the brake pedal has nylon bushings which are lubricated during installation but do not require periodic lubrication. Whenever the linkage is disassembled, however, all friction surfaces should be lightly coated with Lubriplate. Because there is no pedal stop, the pedal is stopped in the released position by contact of the push rod with the stop plate in the master cylinder. No linkage adjustment is possible therefore, pedal height cannot be changed.

The master cylinder contains a fluid reservoir and a cylindrical pressure chamber in which force applied to the brake pedal is transmitted to the fluid which actuates the brake shoes. A breather port and compensating port permit passage of fluid between the fluid reservoir and the pressure chamber during certain operating conditions. A vented cover and flexible rubber diaphragm, at the top of the master cylinder reservoir, seal the hydraulic system from possible entrance of contamination, while at the same time permitting expansion or contraction of fluid within the reservoir without direct venting. In the pressure chamber, a coil spring holds a rubber primary cup against the inner end of the piston. This cup and a rubber

secondary seal on the outer end of the piston prevent escape of fluid past the piston. The piston is retained in the cylinder by a stop plate and a rubber boot is installed over this end of the cylinder to exclude foreign matter.

Each wheel cylinder contains two pistons and two rubber cups which are held in contact with the pistons by a central coil spring with cup expanders to provide a fluid-tight seal. The wheel cylinder cups are of a special heat resisting rubber. Cups of this material must have an expander to hold the lips of the cup out against the wheel cylinder bore.

These cup expanders are crimped on each end of the wheel cylinder spring. The inlet port for brake fluid is located between the pistons so that when fluid pressure is applied, both pistons move outward toward the ends of wheel cylinders. The pistons impart movement to the brake shoes by means of connecting links which seat in pistons and bear against webs of shoes. Rubber boots enclose both ends of cylinder to exclude foreign matter. A valve for bleeding the brake pipes and wheel cylinder is located above the inlet port. See Figure 50-47.

#### d. Self Adjusting Brake

The self-adjusting brake mechanism consists of an actuator, actuator pivot, actuator return spring, override spring and an actuating link. The self-adjusting brake mechanism is mounted on the secondary shoes and operates only when the brakes are applied while the car is moving in a rearward direction and only when the secondary shoe moves a predetermined distance toward the brake drum. See Figure 50-38.

When the car is moved in a rearward direction and the brakes are applied, friction between the primary shoe and the drum forces

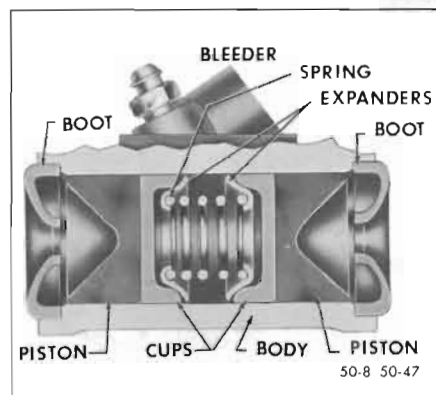

Figure 50-47—Wheel Cylinder Assembly

the primary shoe against the anchor pin. Hydraulic pressure in the wheel cylinder forces the upper end of the secondary shoe away from the anchor pin, the upper end of the actuator is prevented from moving by the actuating link. This causes actuator to pivot on the secondary shoe forcing the actuator lever against the adjusting screw star wheel. If the brake linings are worn enough to allow the secondary shoe to move the predetermined distance, the actuator will turn the adjusting screw one tooth. If the secondary shoe does not move the predetermined distance, movement of the actuator will not be great enough to rotate the adjusting screw.

When the brakes are released, the actuator return spring will return the actuator into adjusting position on the adjusting screw.

#### 50-13 OPERATION OF HYDRAULIC SERVICE BRAKES

**NOTE:** See Sections 50-D and 50-E for power brakes.

When the brakes are fully released, the master cylinder piston is held against the stop plate and the primary cup is held just clear of the compensating port by the master cylinder spring, which also holds the check valve against its seat on the valve seat washer. The pressure chamber is filled

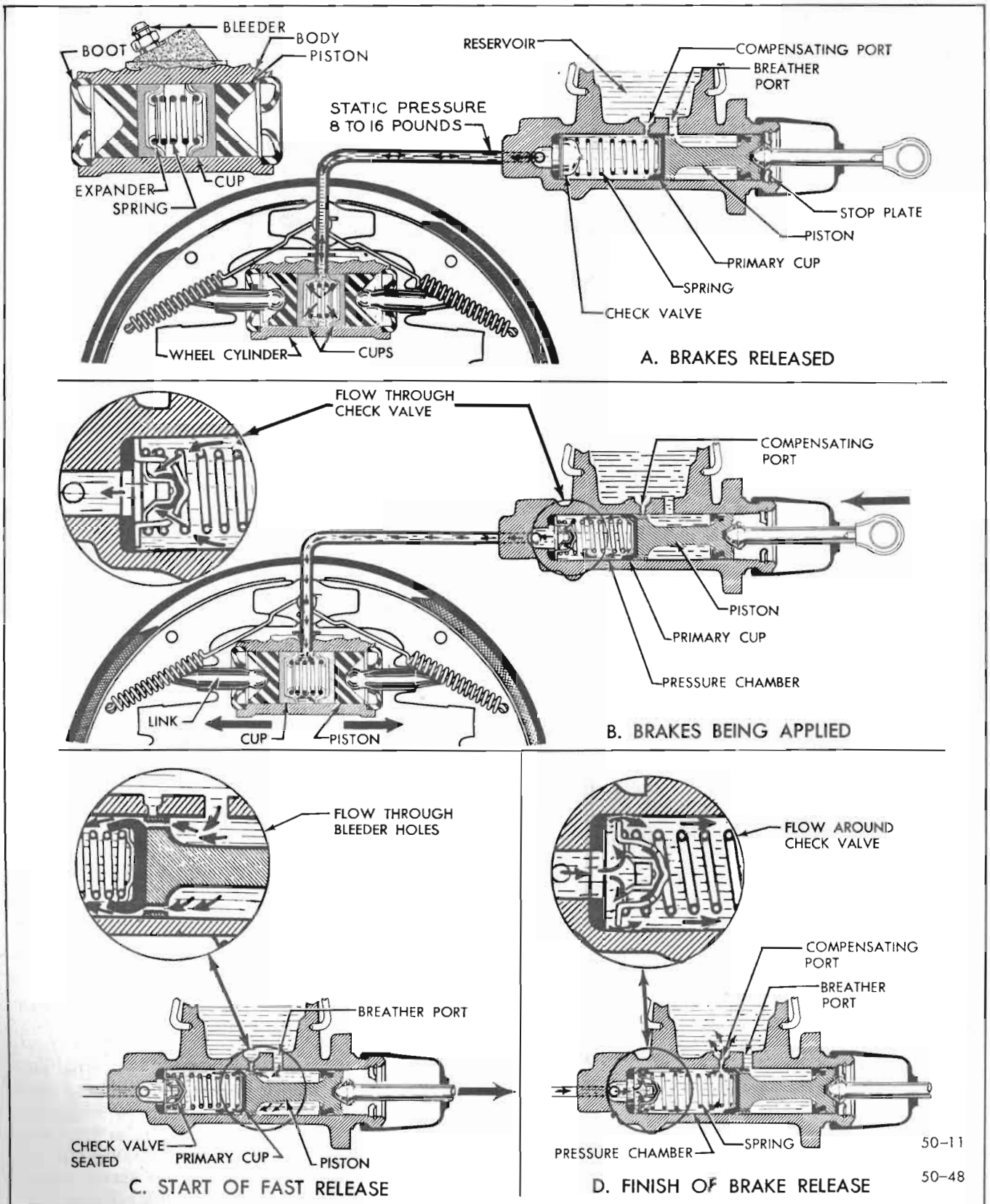

Figure 50-48—Operation of Brake Hydraulic System

50-11

50-48

with fluid at atmospheric pressure due to the open compensating port and reservoir rubber diaphragm. All pipes and wheel cylinders are filled with fluid under a "static" pressure of 8-16 pounds per square inch, which helps to hold the lips of the wheel cylinder cups in firm contact with cylinder walls to prevent loss of fluid or entrance of air. See Figure 50-48, View A.

When the brake pedal is depressed to apply the brakes, the push rod forces the master cylinder piston and primary cup forward. As this movement starts, the lip of the primary cup covers the compensating port to prevent escape of fluid into the reservoir. Continued movement of the piston builds pressure in the pressure chamber and fluid is then forced through holes in the check valve and out into the pipes leading to all wheel cylinders. Fluid forced into the wheel cylinders between the pistons and cups causes the pistons and connecting links to move outward and force the brake shoes into contact with the drums. See Figure 50-48, View B.

Movement of all brake shoes into contact with drums is accomplished with very light pedal pressure. Since pressure is equal in all parts of the hydraulic system, effective braking pressure cannot be applied to any one drum until all of the shoes are in contact with their respective drums; therefore, the system is self-equalizing. After all shoes are contacting the drums, further force on brake pedal builds up additional pressure in the hydraulic system, thereby increasing the pressure of shoes against drums.

On rapid stops some car weight is transferred from the rear to the front wheels, consequently greater braking power is required at front wheels in order to equalize the braking effect at front and rear wheels. Greater force is applied to front brake shoes by

using larger wheel cylinders, so that distribution of braking power is approximately 56% at front wheels and 44% at rear wheels.

When the brake pedal is released, the master cylinder spring forces the pedal back until the push rod contacts the stop plate in master cylinder. This spring also forces the piston and primary cup to follow the push rod and presses the check valve firmly against its seat.

At start of a fast release, the piston moves faster than fluid can follow it in returning from the pipes and wheel cylinders, therefore, a partial vacuum is momentarily created in the pressure chamber. Fluid supplied through the breather port is then drawn through the bleeder holes in piston head and past the primary cup to keep the pressure chamber filled. See Figure 50-48, View C.

As pressure drops in master cylinder, the shoe springs retract all brake shoes and the connecting links push the wheel cylinder pistons inward, forcing fluid back to master cylinder. Pressure of returning fluid causes a rubber disc to close all holes in the check valve and forces the check valve off its seat against the tension of master cylinder spring; fluid then flows around the check valve into the pressure chamber. With the piston bearing against the stop plate and the lip of the primary cup just clear of the compensating port, excess fluid which entered through the bleeder holes or was created by expansion due to increased temperature now returns to reservoir through the uncovered compensating port. See Figure 50-48, View D.

When pressure in wheel cylinders and pipes becomes slightly less than the tension of master cylinder spring, the check valve returns to its seat in the end of the pressure chamber to hold 8-16 pounds per square inch of

"static" pressure in the pipes and cylinders.

## DIVISION III

### SERVICE PROCEDURES

#### 51-5 REPLACE OR RELINE BRAKE SHOES

The most satisfactory method of replacing brake lining is to install new shoe and lining assemblies. This insures brake shoes that are not distorted through use and linings that are properly riveted to shoes and ground to correct radius by accurate factory machinery.

Each brake shoe and lining set listed in the Buick Master Parts Catalog under Group 5.017 is packed in a carton containing two primary and two secondary shoe and lining assemblies, enough for two wheels. Sets are available in standard and .030" oversize for use where brake drums have been rebored.

Brake shoe lining sets are listed in the Buick Master Parts Catalog under Group 5.018 if the old brake shoes are to be relined. Each lining set is packed in a carton containing two primary and two secondary linings, enough for two wheels, and packaged with enough rivets for installation on shoes. Linings are shaped, drilled, and ground to correct thickness and radius. Lining sets are available in standard and .030" oversizes.

Brake linings are made of asbestos for its heat resisting qualities and compounds of bonding material for strength. Some bonding materials are used for their lubricating qualities to guard them against drum scoring while others are used to control the friction producing property of the lining, called "coefficient of friction." Good molded linings also have imbedded particles of material used to control friction and wear. When linings are ground, some of

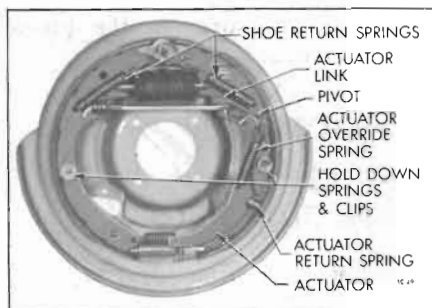

Figure 50-49—Rear Left Wheel Brake Assembly

the surface particles may be pulled out leaving a pitted appearance. These pits do not affect lining efficiency.

The heat generated by friction will produce different effects in different compounds of bonding material. Some compounds increase friction with increased temperature, which might cause grabbing or locking. Other compounds lose friction with increased temperature, which might cause substantially lowered braking power.

Brake lining compounds must be carefully selected to produce the braking friction required at the temperatures normally attained in each vehicle application.

#### a. Removal and Inspection

**NOTE:** When paragraph references in parentheses ( ) have an asterisk (\*), the operation referred to is additional work not covered by the standard replacement operation.

1. Jack up car in a safe manner, remove wheel and brake drum (rear) or hub and drum assembly (front).

**NOTE:** Safety stops located on the backing plates will prevent pistons from leaving the wheel cylinders; however, brake pedal must not be operated while a brake drum is removed since damage to wheel cylinder rubber boots will result.

**NOTE:** It may be necessary to back off the brake shoe adjustment before the brake drums can be removed. To back off shoe adjustment, rotate shoe adjusting screw upward. See Figure 50-36.

2. Unhook the primary and secondary shoe return springs using large pliers.
3. Remove shoe hold down springs.
4. Lift up on actuator, unhook actuating link from anchor pin, then remove.
5. Spread shoes to clear wheel cylinder connecting links, remove parking brake strut and spring (rear only), disconnect cable from parking brake lever, remove shoes from the backing plate.
6. Separate the brake shoes by removing adjusting screw and lock spring. Remove parking brake lever from secondary brake shoe (rear only). See Figure 50-49.
7. Clean all dirt out of brake drum, using care to avoid getting dirt into front wheel bearings. Inspect drums and replace or recondition if required (\*par. 51-7). If front hub and drum assembly is removed, inspect wheel bearings and oil seal and replace faulty parts (\*Group 100).
8. Blow all dirt from brake assemblies and inspect for any unusual condition.
9. Carefully pull lower edges of wheel cylinder boots away from cylinders and note whether interior is wet with brake fluid. Fluid at this point indicates leakage past piston cup, requiring overhaul of wheel cylinder (\*par. 51-8).
10. If working at rear wheels, inspect backing plate for oil leak past wheel bearing oil seals. Correct any leak by installation of new seals (\*Group 40).
11. Check all backing plate at-

taching bolts to make sure they are tight. Using fine emery cloth, clean all rust and dirt from shoe contact surfaces on plate.

#### b. Relining Brake Shoes

If old brake shoes are to be relined, inspect shoes for distortion and for looseness between the rim and web. Discard any shoes found with these defects. If shoes are serviceable, be governed by the following points in installing new linings:

1. Remove old linings by drilling out rivets. Punching rivets out will distort shoe rim. Thoroughly clean surface of shoe rim and file off any burrs or high spots.
2. Use Buick brake lining or equivalent and the rivets included in lining package which are of correct size. The rivets must fit the holes and the solid body of rivet should extend through the shoe rim, but no farther.

**CAUTION:** Keep hands clean while handling brake lining. Do not permit oil or grease to come in contact with lining.

3. Start riveting at center of shoe and lining and work toward the ends. Use a roll set for riveting; a star set might split the tubular end and then the rivet would not fill the hole. The primary lining is shorter than secondary lining, therefore, the rivet holes at each end of shoe rim are not used.
4. After riveting is completed, lining must seat snugly against shoe with no more than .005" separation midway between rivets. Check with a .004" (go) and a .006" (no go) feel gauge.

#### c. Installation and Adjustment

1. On rear brakes only, lubricate fulcrum end of parking brake lever with Delco Brake Lubricant or equivalent, then attach lever to secondary shoe. Make sure that lever is free moving.

2. Connect brake shoes together with lock spring; then place adjusting screw in position.

**CAUTION:** WHEN INSTALLING ADJUSTING SCREW, MAKE SURE RIGHT HAND THREAD ADJUSTING SCREW IS ON LEFT SIDE OF CAR AND LEFT HAND THREAD ADJUSTING SCREW ON RIGHT SIDE OF CAR. MAKE CERTAIN STAR WHEEL LINES UP WITH ADJUSTING HOLE IN BACKING PLATE.

3. Lubricate shoe contact surfaces on backing plate with a thin coating of Delco Brake Lubricant or equivalent. On rear brakes, sparingly apply same lubricant where brake cable contacts backing plate.

4. Place brake shoes on backing plate, at the same time engaging shoes with wheel cylinder links. The primary shoe (short lining) goes forward. On rear brakes, connect cable to parking brake lever and install strut and spring between lever and primary shoe as shown in Figure 50-49.

5. Install actuator, actuator return spring and actuating link.

**NOTE:** If old brake shoe return springs are nicked, distorted or of doubtful strength (distorted from heat), it is advisable to install new ones.

6. Install shoe hold down springs.

7. Install the primary and secondary shoe return springs using large pliers being careful not to distort springs.

8. Install brake drums and wheels. Lubricate and adjust front wheel bearings. Remove all adjusting hole covers from backing plates.

9. Install J-21231 through adjusting hole to move actuator off adjusting screw. See Figure 50-36.

10. Turn adjusting screws to provide an equal two-hand drag and back-off 30 notches for proper

shoe clearance (par. 50-10).

11. If any hydraulic connections were disturbed, bleed hydraulic system (par. 56-4). If new parts were installed in system, flushing of hydraulic system is recommended.

12. Adjust parking brake as described in paragraph 50-11.

13. Inspect all brake pipes, hoses and connections for evidence of fluid leakage. Tighten any leaking connection. Then apply heavy pedal pressure to brake pedal and recheck connections.

14. Check fluid level in master cylinder and add fluid if necessary.

15. Check brake pedal for proper feel and for proper return.

16. Remove jacks and road test car for proper brake action (par. 59-4).

**CAUTION:** Brakes must not be severely applied immediately after installation of new brake shoes or linings. Severe application may permanently damage new linings and may score brake drums. When linings are new, they must be given moderate use for several days until burnished.

#### 51-6 REPAIR BRAKE LININGS

This procedure is to be used when brake action is unequal, severe, hard, noisy or otherwise unsatisfactory, but brake linings have had little wear.

1. Check fluid level in master cylinder and add fluid if necessary.

2. Check brake pedal for proper feel and for proper return.

3. Jack up car in a safe manner and remove all wheels.

4. Remove all brake drums.

**CAUTION:** Brake pedal must not be operated while drums are removed.

5. Clean all dirt out of brake

drums using care to avoid getting dirt into front wheel bearings. Inspect drums and replace or recondition if required (par. 51-7).

6. Blow all dirt from brake assemblies, then inspect brake linings for uneven wear, oil soaking, loose rivets or imbedded foreign particles. If linings are oil soaked, replacement is required.

7. If linings are otherwise serviceable, tighten or replace loose rivets and thoroughly clean all steel or other imbedded particles from surfaces and rivet counterbores of linings.

8. If brake linings at any wheel show a spotty wear pattern indicating uneven contact with brake drum, it is advisable to true up the linings with a light grinding cut, if suitable grinding equipment is available. If brake action is unequal, severe or hard, indicating that brake shoes are not centralized in drums, the grinder may also be used to correct this condition.

Grinding equipment which locates and swings off the wheel spindle or axle shaft may be used to grind shoes concentric with drums or a bench mounted grinder may be used to grind shoes to the proper radius (.010" less than drum radius). The instructions of equipment manufacturer must be carefully followed.

9. Check all backing plate bolts to make sure they are tight.

10. Lubricate front wheel bearings, if necessary. Install front hub and drum assemblies and adjust wheel bearings.

11. Install brake drums. Remove all adjusting hole covers.

12. Install all wheels, turn adjusting screws to provide an equal two-hand drag and back-off 30 notches (par. 50-9).

13. Install adjusting hole cover in backing plate when adjustment is complete.



14. Remove jacks and road test car for proper brake action.

**CAUTION:** Brakes must not be severely applied immediately after installation of reground brake shoes or linings. Severe application may permanently damage new linings and may score brake drums. When linings are new, they must be given moderate use for several days until burnished.

### 51-7 INSPECTING AND RECONDITIONING BRAKE DRUMS

Whenever brake drums are removed, they should be thoroughly cleaned and inspected for cracks, scores, deep grooves and out-of-round. Any of these conditions must be corrected since they can impair the efficiency of brake operation and cause premature failure of other parts.

#### a. Cracked, Scored, or Grooved Drum

**WARNING:** A cracked drum is unsafe for further service and must be replaced. Do not attempt to weld a cracked drum.

Smooth up any slight scores by polishing with fine emery cloth. Heavy or extensive scoring will cause excessive brake lining wear and it will probably be necessary to rebores in order to true up the braking surface.

If the brake linings are slightly worn and drum is grooved, the drum should be rebored just enough to remove grooves and the ridges in the lining should be lightly removed with a lining grinder.

If brake linings are more than half worn, but do not need replacement, the drum should be polished with fine emery cloth but should not be rebored. At this stage, eliminating the grooves in drum and smoothing the ridges on

lining would necessitate removal of too much metal and lining, while if left alone, the grooves and ridges match and satisfactory service can be obtained.

If brake linings are to be replaced, a grooved drum should be rebored for use with oversize linings (subpar. c, following). A grooved drum, if used with new lining, will not only wear the lining, but will make it difficult, if not impossible, to obtain efficient brake performance.

#### b. Out-of-round or Tapered Drum

An out-of-round drum makes accurate brake shoe adjustment impossible and is likely to cause excessive wear of other parts of brake mechanism due to its eccentric action. An out-of-round drum can also cause severe and very irregular tire tread wear.

A drum that is more than .010" out-of-round on the diameter is unfit for service and should be rebored (subpar. c, following). A drum that has more than .005" taper should be rebored. Out-of-round as well as taper and wear can be accurately measured with an inside micrometer fitted with proper extension rods.

When measuring a drum for out-of-round, taper and wear, take measurements at the open and closed edges of machined surface and at right angles to each other. Standard drums are machined to an inside diameter of 11.997" to 12.022", with runout of braking surface held within .005" total indicator reading.

#### c. Reboring Brake Drum

If a drum is to be rebored, enough metal should be removed to obtain a true, smooth braking surface. If a drum does not clean up when rebored to a diameter of 12.080", it must be replaced. Removal of more metal will affect dissipation of heat and may cause distortion of the drum.

A newly bored drum should always have center contact with the shoes on initial break-in, thus insuring greater uniformity in brake performance with less danger of brake pulling. To get this desired position, the shoe radius should always be .010" less than the drum radius (or .020" less on the diameter). This fit may be accomplished by either grinding the shoes or boring the drums, whichever is more practical.

If cleaning up a drum requires boring to a size larger than 12.050", then .030" oversize lining must be used.

Fit between the brake shoes and the drum must always be the same on both sides of the car to get equal braking action.

Brake drums may be refinished either by turning or grinding. Best brake performance is obtained by turning drums with a very fine feed. Too coarse a feed will cause a condition on the car called "shoe slap" in which the shoes attempt to follow the spiral of the cut, then snap back against the backing plate. Ground and polished drums do not wear in as readily as turned drums and are more likely to cause unequal braking when new. To insure maximum lining life, the refinished braking surface must be smooth and free from chatter or tool marks.

Run-out of the refinished surface of brake drum must not exceed .005" total indicator reading. Run-out (sideways wobble) of the open edge of drum must not exceed .030".

#### d. Brake Drum Balance

During manufacture brake drums are balanced within 3 ounce inches by fastening weights as required near the rim. These weights must not be removed.

After drums are rebored, or if difficulty is experienced in maintaining proper wheel balance, it is recommended that brake drums be checked for balance. Brake drums may be checked for balance on most off-the-car wheel balancers.

### 51-8 BRAKE WHEEL CYLINDER OVERHAUL

1. Remove wheel, drum and brake shoes. Be careful not to get grease or dirt on brake lining.

2. Disconnect brake pipe or hose from wheel cylinder and cover opening with tape to prevent entrance of dirt. Remove wheel cylinder from backing plate.

3. Remove links, boots, pistons, cups, cup expanders and spring from cylinder. Remove bleeder valve.

4. Discard rubber boots, expander assembly and piston cups. Thoroughly clean all other parts with hydraulic brake fluid or de-natured alcohol.

**CAUTION:** Do not use anti-freeze alcohol, gasoline, kerosene or any other cleaning fluid that might contain even a trace of mineral oil.

5. Inspect pistons and cylinder bore for scores, scratches or corrosion. Light scratches may be polished with crocus cloth. Do not use emery cloth or sandpaper. Slight corrosion may be cleaned with fine steel wool and alcohol. If scratches or corroded spots are too deep to be polished satisfactorily the cylinder should be replaced since honing is not recommended.

6. Dip internal parts in brake fluid and reassemble wheel cylinder. When installing piston cups, use care to avoid damaging the edges.

7. Install wheel cylinder on brake backing plate and connect brake pipe or hose.

8. Install brake shoes, drum and wheel, then flush and bleed hydraulic system (par. 56-4).

9. Adjust brakes (par. 50-9), then road test car for brake performance (Division IV).

### 55-2 BRAKE MASTER CYLINDER OVERHAUL

#### a. Removal of Brake Master Cylinder

1. Disconnect brake pipe from master cylinder and tape end of pipe to prevent entrance of dirt.

2. Disconnect brake pedal from master cylinder push rod by removing washer and retainer. See Figures 50-45 and 50-46.

3. Remove two nuts holding master cylinder to dash and remove cylinder from car. Be careful not to drip brake fluid on exterior paint.

#### b. Disassembly of Brake Master Cylinder

1. Clean outside of master cylinder thoroughly. Remove reservoir cover and diaphragm. Turn cylinder over and pump push rod by hand to drain all brake fluid. Always discard used fluid.

2. Place master cylinder in a vise so that the lock ring can be removed from the I.D. of the bore. Remove rubber boot. Remove lock ring, then remove push rod with stop plate. See Figure 50-51.

3. Remove and discard piston, primary cup, spring, check valve and valve seat washer. Also discard boot, lock ring and reservoir diaphragm. These parts are furnished in the master cylinder repair kit (Group 4.649).

4. Thoroughly clean master cylinder with brake fluid or de-natured alcohol.

**CAUTION:** Do not use anti-freeze alcohol, gasoline, kero-

sene or any other cleaning fluid that might contain even a trace of mineral oil.

#### c. Inspection of Brake Master Cylinder

Inspect cylinder bore for scores, scratches or corrosion. Light scratches in cylinder bore may be polished with crocus cloth. Do not use emery cloth or sandpaper. Slight corrosion may be cleaned with fine steel wool and alcohol.

Make certain that compensating port in cylinder is clear; however, do not run a wire through port as this may result in leaving a burr which will cut a groove in primary cup.

If scratches or corroded spots are too deep to be polished satisfactorily, the cylinder should be replaced since honing is not recommended and oversize pistons and cups are not furnished for service.

Wheel and master cylinder bores have a hard, highly polished "bearingized" surface produced by diamond boring followed by rolling under very heavy pressure. Honing destroys the bearingized surface, leaving a softer and rougher surface which will cause more rapid wear of piston and rubber cups. Higher friction produced by the rougher surface will also reduce braking power for a given pressure on brake pedal.

The maximum allowable clearance between piston and cylinder bore is .0055". If this clearance is increased by honing, the heavy pressure of brake fluid may force rubber of the cup into the clearance and cause sticking or early failure of the cup. If a choice must be made between honing or replacement of the cylinder, it must be remembered that while a new cylinder may be more expensive, a honed cylinder may not give a satisfactory length of service.

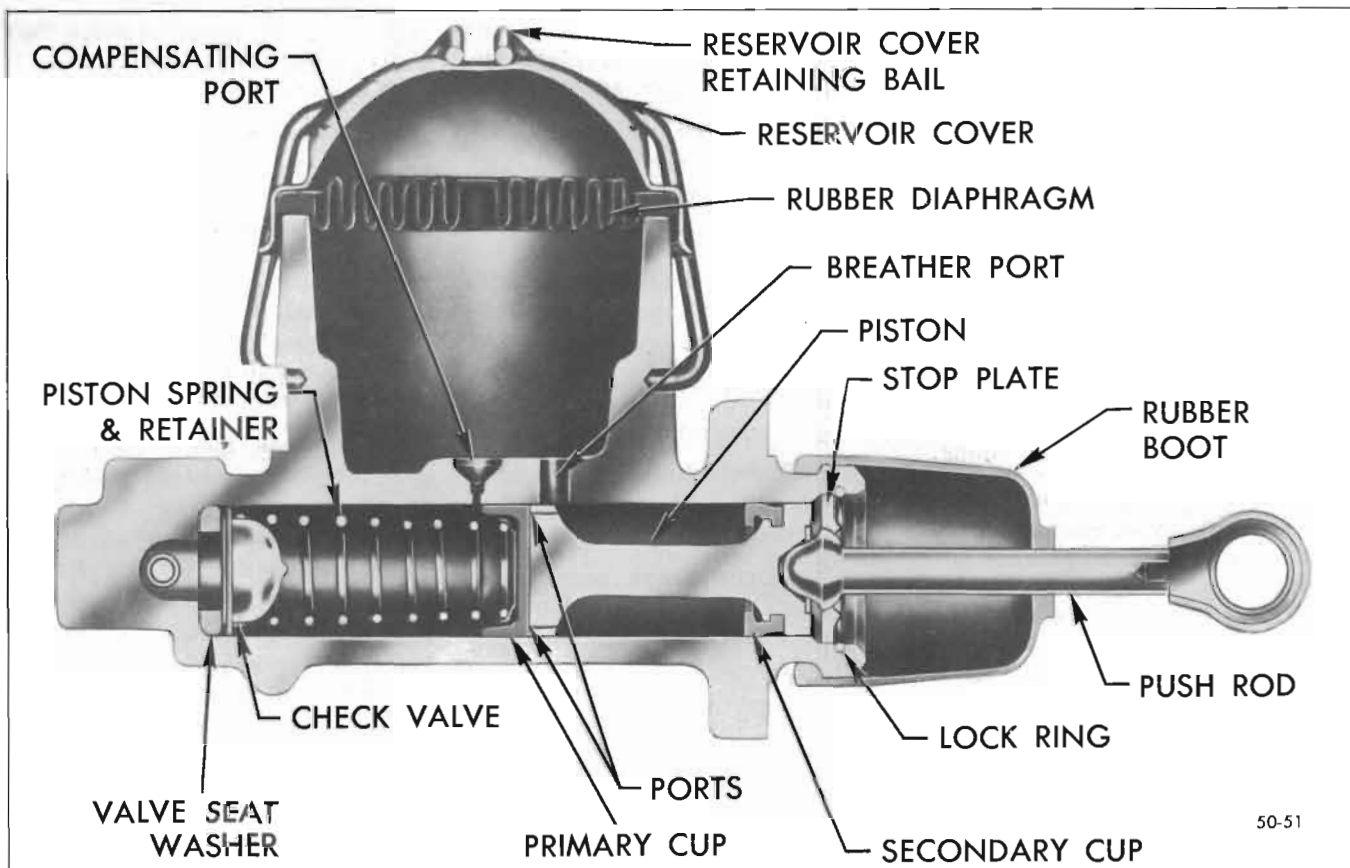

Figure 50-51—Standard Brake Master Cylinder

#### d. Assembly of Brake Master Cylinder

1. Dip all internal parts in clean brake fluid just before installation. Also wet master cylinder bore with brake fluid.

2. Install valve seat washer, check valve, spring, primary cup and piston with secondary cup. Then install push rod and stop plate assembly. Hold push rod in and install lock ring. Check for proper seating of lock ring with a hard pull on push rod.

3. Install rubber boot. Then install rubber diaphragm and reservoir cover.

#### e. Installation of Brake Master Cylinder

1. Install master cylinder on dash. Torque nut to 20-28 lb. ft.

2. Connect push rod to brake pedal by installing spring washer, flat washer and pin.

3. Connect brake pipe to master cylinder.

4. Bleed hydraulic system as described in paragraph 56-4. Bleed left front wheel cylinder first and check for proper pedal feel. If system still has air in it, bleed other three wheel cylinders. After bleeding, bring fluid to 1/8" below lip of reservoir opening.

5. Check brake pedal for full return and check stop light switch adjustment as described in paragraph 50-9 (b).

6. Road test car for proper brake performance (par. 59-4).

#### 56-3 REPLACING BRAKE PIPES

Since brake pipe assemblies (except master cylinder to distributor pipe) are not available from

Buick Parts Warehouses, it is therefore necessary to order service bulk tubing and fittings to make up any pipe assembly which is needed. All brake pipes must be made of tin-plated or copper-coated wrapped steel tubing with the ends double lap flared.

**CAUTION:** Never use copper tubing because copper is subject to fatigue cracking which would result in brake failure.

To make up a brake pipe assembly, proceed as follows:

1. Procure the recommended tubing and steel fitting nuts of the correct size. (Outside diameter of tubing is used to specify size.)

2. Cut tubing to length. The correct length may be determined by measuring the old pipe using a cord and adding 1/8" for each double lap flare.

3. Double lap flare tubing ends using a suitable flaring tool. Follow the instructions included in the tool set.

**CAUTION:** Make sure fittings are installed before starting second flare.

**NOTE:** Double lap flaring tool must be used as single lap flaring tools cannot produce a flare strong enough to hold the necessary pressure.

4. Bend pipe assembly to match old pipe.

#### 56-4 FILLING, BLEEDING AND FLUSHING BRAKE HYDRAULIC SYSTEM

##### a. Filling Brake Master Cylinder

The master cylinder must be kept properly filled to insure adequate reserve and to prevent air from entering the hydraulic system. However, because of expansion due to heat absorbed from brakes and from engine, master cylinder must not be overfilled.

The brake fluid reservoir is on the master cylinder which is located under the hood on the left side of the dash.

Thoroughly clean reservoir cover before removal to avoid getting dirt into reservoir. Remove cover and diaphragm. Add fluid as required to bring level 1/8" below lip of reservoir opening. Use Delco Supreme No. 11 Hydraulic Brake Fluid or equivalent.

**CAUTION:** Do not use shock absorber fluid or any other fluid which contains mineral oil. Do not use a container which has been used for mineral oil. Even a trace of mineral oil will cause swelling and distortion of rubber parts in the hydraulic brake system.

##### b. Bleeding Brake Hydraulic System

A bleeding operation is necessary to remove air whenever it is introduced into the hydraulic brake

system. Since air is compressible and hydraulic fluid is not, the pressure of air in the system is indicated by a springy, spongy feeling on the brake pedal accompanied by poor braking action.

Air will be introduced into the hydraulic system if the brake pedal is operated when the fluid is too low in master cylinder reservoir. Air will also enter the system whenever any part of hydraulic system is disconnected.

It will be necessary to bleed the hydraulic system at all four wheel cylinders if air has been introduced through low fluid level or by disconnecting brake pipe at master cylinder. If brake pipe is disconnected at any wheel cylinder, then that wheel cylinder only need be bled. If pipes are disconnected at any fitting located between master cylinder and wheel cylinders, then all wheel cylinders served by the disconnected pipe must be bled. See Figures 50-42, 50-43 and 50-44.

##### c. Sequence of Bleeding Wheel Cylinders

It is advisable to bleed one wheel cylinder at a time to avoid allowing fluid level in reservoir to become dangerously low. The correct sequence of bleeding is left front, right front and then rear wheels, either first. This sequence expels air from the lines and wheel cylinders nearest to the master cylinder first and eliminates the possibility that air in a line close to the master cylinder may enter a line farther away after it has been bled.

**CAUTION:** Do not perform bleeding operation while any brake drum is removed.

##### d. Bleeding Wheel Cylinder Without Pressure Tank

1. Fill master cylinder (subpar. a, above).

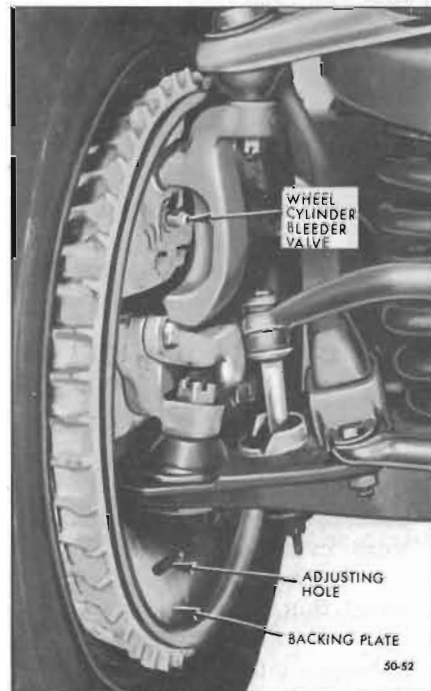

Figure 50-52—Right Front Wheel and Brake Assembly

2. Install Wrench J-21472 on bleeder valve. Slip a brake bleeder tube over ball of wheel cylinder bleeder valve. Place lower end of bleeder tube in a clean glass jar that is partially filled with clean brake fluid. Position end of tube so that it will remain submerged under fluid during bleeding operation. Unscrew bleeder valve 3/4 of a turn. See Figure 50-52.

3. Depress brake pedal a full stroke, then allow pedal to return slowly to released position. Allowing pedal to return quickly may draw air into system. Continue operating pedal in this manner until fluid flows from bleeder tube into glass jar in a solid stream that is free of air bubbles, then close the bleeder valve securely and remove bleeder tube.

4. Frequently check master cylinder to make sure that it contains fluid. Allowing reservoir to be emptied will cause air to be drawn into hydraulic system.

5. When bleeding operation is completed at all wheel cylinders where needed, make sure that fluid level is within 1/8" of top of reservoir. Install rubber diaphragm and cover.

6. Discard the brake fluid deposited in glass jar during bleeding operation. It is poor economy to attempt to clean fluid that has once been used.

#### e. Bleeding Wheel Cylinder With Pressure Tank

**IMPORTANT:** When using a pressure tank, air bubbles may form in the tank and enter the brake hydraulic system. To avoid this, observe the following points when handling a pressure tank: (1) Do not shake or agitate the pressure tank after air pressure has been added or is being added. (2) Allow pressure tank to stand in one position as much as possible and bring air hose to tank when adding head of air. (3) Make certain the valves on the pressure tank lines are not defective allowing air to be sucked in when fluid passes through the lines. (4) Pressure tank should be kept at least 1/3 full of fluid to avoid air bubbles forming. (5) If pressure tank is full of air bubbles, release air pressure and bubbles will increase in size, be forced to top of fluid, and escape.

1. Thoroughly clean master cylinder reservoir cover and surrounding area, then remove cover and diaphragm.

2. Make sure that pressure tank is at least 1/3 full of specified brake fluid and that hose and master cylinder reservoir are filled with fluid. Attach hose to master cylinder reservoir adapter cover.

3. Install Bleeder Wrench J-21472 on bleeder valve. Slip a brake

bleeder tube over ball of wheel cylinder bleeder valve. Place lower end of bleeder tube in a clean glass jar. Unscrew bleeder valve 3/4 of a turn.

4. Open pressure tank hose valve to apply fluid to master cylinder under pressure that does not exceed 35 pounds. It is not necessary to pump the brake pedal when using pressure tank.

5. When fluid flows from bleeder tube into glass jar in a solid stream that is free of air bubbles, that particular cylinder and line are bled. Tighten bleeder valve securely and remove bleeder tube.

6. When bleeding operation is completed at all wheel cylinders where needed, make sure that fluid level is 1/8" below top of master cylinder reservoir. Install rubber diaphragm and cover.

#### f. Flushing Brake Hydraulic System

It is recommended that the entire hydraulic system be thoroughly flushed whenever new parts are installed in the hydraulic system. Flushing is also recommended if there is any doubt as to the grade of fluid in the system or if fluid has been used which contains the slightest trace of mineral oil.

Flushing is performed at each wheel cylinder in turn, and in the same manner as the bleeding operation except that bleeder valve is opened 1-1/2 turns and the fluid is forced through the pipes and wheel cylinder until it emerges clear in color. Approximately one quart of fluid is required to flush the hydraulic system thoroughly.

When flushing is completed at all wheel cylinders, make certain that master cylinder reservoir is filled to proper level.

## DIVISION IV

### TROUBLE DIAGNOSIS

#### 59-4 INSPECTING AND TESTING BRAKES

##### a. Inspecting Brakes

At reasonably frequent intervals, the brakes should be inspected for pedal reserve, which is the clearance between the pedal pad and the toeboard when the brake pedal is firmly depressed while brakes are cold.

Pedal reserve on manual brake-equipped cars should not be less than 2-1/4". On power brake-equipped cars, pedal reserve should not be less than 1-1/2". Heat generated by high speed stops will expand brake drums and increase shoe clearance, thereby permitting pedal pad to go closer to toeboard when brakes are hot.

Brakes should be corrected whenever the action becomes unduly severe, erratic or uneven. Brake shoe linings should not be permitted to wear down until rivets contact drums because drums will be scored. As car mileage approaches the point where relining may be required, it is advisable to remove one or more drums for inspection of lining in order to avoid the possibility of damaging brake drums.

##### b. Testing Brakes

Overall brake performance cannot be properly tested with the wheels jacked up because this procedure does not test the self-energizing servo action of the brake shoes and the effect of car weight distribution on deceleration.

Brakes should be tested on dry, clean, reasonably smooth and level roadway. A true test of brake performance cannot be made if roadway is wet, greasy,

or covered with loose dirt so that all tires do not grip road equally. A true test cannot be made if roadway is crowned so as to throw weight of car toward wheels on one side or is so rough that wheels tend to bounce.

Test brakes at different car speeds with both light and heavy pedal pressure; however, avoid locking the wheels and sliding the tires on roadway. Locked wheels and sliding tires do not indicate brake efficiency since heavily braked but turning wheels will stop the car in less distance than locked wheels. More tire-to-road friction is present with a heavily braked turning tire than with a sliding tire.

#### c. External Conditions That Affect Brake Performance

In addition to roadway conditions mentioned (subpar. b), the following external conditions may affect brake performance and should be corrected before work is done on the brake mechanism.

1. Tires. Tires having unequal contact and grip on road will cause unequal braking. Tires must be equally inflated and non-skid tread pattern of right and left tires must be approximately equal. Right and left tires must have approximately the same diameter.

2. Car Loading. When car has unequal loading, the most heavily loaded wheels require more braking power than others. A heavily loaded car requires more braking effort.

3. Front Wheel Bearings. A loose front wheel bearing permits the drum to tilt and have spotty contact with brake shoe linings, causing erratic brake action. See Group 100.

4. Front End Alignment. Misalignment of the front end, particularly in regards to limits on camber and theoretical king pin

inclination, will cause brake action to appear unequal between sides.

5. Shock Absorbers. Faulty shock absorbers that permit bouncing of car on quick stops may give the erroneous impression that brakes are too severe.

### 59-5 BRAKE TROUBLE INDICATIONS AND CORRECTIONS

#### a. Brake Pedal Travel Excessive or Pedal Goes to Toeboard

1. Excessive Brake Shoe Clearance. Excessive clearance is indicated if a good brake is obtained after pumping brake pedal several times. Condition may be caused by wear of brake lining or by improperly functioning self-adjusting mechanism.

2. Fluid Reservoir Empty. If fluid reservoir is empty, a good brake cannot be obtained by pumping brake pedal. Fill reservoir (par. 56-4) and check for springy pedal action (subpar. b, below).

3. Air in Hydraulic System. Air in hydraulic system will cause a springy action of brake pedal. If volume of air is large, the pedal will go to toeboard under normal pressure. See subparagraph b below for causes of air in hydraulic system. Bleed hydraulic brake system (par. 56-4).

4. Fluid Leak in Hydraulic System. A leak in the hydraulic system will allow the pedal to go to the toeboard gradually under continued pressure. An external leak is indicated by loss of fluid in fluid reservoir. Check all brake pipe connections and all cylinders for evidence of fluid loss. If no leaks are found, remove master cylinder, disassemble and check for internal leak. Check for scoring or other damage to cylinder bore, piston or primary cup (par. 55-2).

5. Improper Brake Fluid. Improper brake fluid may boil due to high temperature. Flush system and refill with specified brake fluid (par. 56-4).

#### b. Springy or Spongy Action of Brake Pedal

1. Air in Hydraulic System. Air will enter the hydraulic system if there is not sufficient reserve fluid in the master cylinder reservoir. A disconnected pipe permits air to enter the system. A leaking check valve causes loss of static pressure in the system, thus permitting air to be drawn in past wheel cylinder cups.

Clean or replace leaking check valve as required. Fill reservoir and bleed hydraulic system (par. 56-4).

2. Brake Drum Out-of-Round. This is usually indicated by an unstable action of brake pedal. Check brake drums and true up if necessary (par. 51-7).

#### c. Brakes Severe on Light Pedal Pressure

1. Loose Front Wheel Bearings. Check for play in bearings with wheels jacked up and adjust if necessary (Group 100).

2. Loose Brake Backing Plate. Tighten all backing plate bolts.

3. Brake Shoes Not Properly Adjusted. Inspect self-adjuster mechanism.

4. Excessive Dust in Brake Assemblies. When excessive dust is present, brakes are usually more severe. Thoroughly clean brake shoe linings to remove embedded dirt (par. 51-6).

5. Faulty Brake Shoe Linings or Drums. Charred linings or scored drums cause grabbing action. A small amount of grease or brake fluid on linings may cause grabbing action. Replace linings and

true up or replace scored drums (par. 51-7).

6. Brake Shoe Linings Reversed. The primary lining is shorter than secondary lining and of different composition. Install brake shoes in proper positions (par. 51-5).

#### d. Excessive Pedal Pressure Required

1. Hard Brake Pedal. If brake shoes do not have full contact with drums, excessive pedal pressure is required to obtain effective braking. Repair brake linings (par. 51-6).

2. Foreign Substances on Brake Linings. Check for grease, brake fluid or other foreign substances on linings. Replace grease or fluid soaked linings (par. 51-5). Sand off other foreign substances.

3. Improper Brake Lining. Brake lining is selected to match car characteristics. Improper lining can give poor performance or feel. Install standard Buick lining or equivalent (par. 51-5).

4. Improper Brake Fluid. Fluid containing substances injurious to rubber will cause swelling of rubber cups in master and wheel cylinders. Replace rubber cups, flush system and refill with specified brake fluid (par. 51-8, 55-2, 56-4).

#### e. Brakes Drag at One Wheel

1. Loose Front Wheel Bearings. Check for play in bearings with wheel jacked up and adjust if necessary (Group 100).

2. Insufficient Clearance at Brake Shoes. Check self-adjuster mechanism.

3. Weak or Broken Brake Shoe Spring. Replace spring and check brake shoe adjustment (par. 50-9).

4. Wheel Cylinder Piston Stuck or Cups Distorted. These may be caused by dirt in hydraulic fluid,

improper fluid or previous use of a cleaning fluid which is detrimental to rubber parts. Overhaul wheel cylinder and replace any defective parts (par. 51-8). It is also advisable to flush hydraulic system to prevent repetition of trouble (par. 56-4).

5. Obstruction in Brake Pipes or Hoses. Obstruction may be caused by foreign material, damaged pipe, kinked or deteriorated brake hose. Flush hydraulic system (par. 56-4) or replace damaged or defective part as required.

#### f. Brakes Drag at All Wheels

1. Insufficient Clearance at Brake Shoes. Check self-adjuster mechanism.

2. Master Cylinder Piston Compensating Port Closed. If the compensating port is plugged by foreign material or is covered by the piston primary cup when brake pedal is in released position, high pressure will be maintained in hydraulic system and brake shoes will be held in contact with drums. This condition is indicated by lack of normal pedal travel and a very solid feel when pedal is depressed.

Make certain that pedal is free on pivot and at push rod connection.

If freeing up brake pedal does not correct the trouble, remove master cylinder for disassembly and thorough cleaning (par. 55-2).

**CAUTION:** Never insert a test wire through compensating port as this may leave a burr, which will cut a groove in primary cup.

3. Wheel Cylinder Piston Cups Distorted. Swollen and distorted rubber parts in master cylinder indicate the presence of a mineral base oil such as kerosene, gasoline or engine oil in hydraulic system. Such substances will cause all rubber parts to swell and distort; therefore, it is necessary to thoroughly flush the

hydraulic system (par. 56-4) and replace all rubber parts.

#### g. Car Pull to One Side

1. Tires Unequal. Tires unequally inflated or having unequal wear of treads or different non-skid tread designs may cause car to pull to one side when brakes are applied. Inflate all tires to specified pressure (Group 100). Rearrange tires if necessary so that tread non-skid characteristics are more nearly equal on both sides of car.

2. Loose Front Wheel Bearings. Check for play in bearings with wheels jacked up and adjust if necessary.

3. Out-of-Round or Scored Brake Drums. True up or replace as required (par. 51-7).

4. Brake Linings Not Matched, or Improperly Placed. Brake linings must be of same composition on left and right sides of car, otherwise unequal braking action will result. If primary and secondary linings are interchanged at any wheel, unequal braking action will be obtained. Replace or change linings as required (par. 51-6).

5. Foreign Substances on Some Brake Linings. Any foreign substance on linings will affect braking action. Thoroughly clean any linings having water, sand, paint, imbedded particles of metal, etc., on surface. Sand or brush the affected surface--do not use any liquid cleaning agent. Linings having oil, grease, or hydraulic fluid on linings cannot be cleaned satisfactorily and must be replaced (par. 51-6).

6. Loose Brake Backing Plate. Tighten all backing plates.

7. Unequal Camber. If car has a tendency to lead to one side when driven on a level road, it will also pull to one side when brakes are applied. Adjust camber to specified limits (Group 100).

8. Brake Shoes Improperly Set. Although hydraulic brakes are self-equalizing when applying pressure at each brake shoe, the brake shoes will not hold equally if not centered in drums or if the wear pattern is not uniform on all four shoes.

#### **h. Brakes Noisy**

1. Brake Drum Condition. Carefully inspect brake drums for out-of-round, scoring or cracks. Rebore any drum if out-of-round or scored (par. 51-7). Replace any drum which is cracked or has hard spots in braking surface.

2. Foreign Material Imbedded in Lining. Metallic particles or grit imbedded in brake lining will cause squeaking. Sand the surfaces of linings and remove all particles of metal. In some cases, it may be necessary to dress the lining surfaces with a portable resurfacing machine in order to properly clean the surfaces and insure good contact with brake drums.

3. Linings Loose on Brake Shoes. Replace any rivets that are loose. Lining must be tightly held against brake shoe flange, particularly at the ends (par. 51-6).

4. Bent Brake Backing Plate. True up or replace backing plate.

5. Improper Brake Shoe Lining. Install standard Buick lining or equivalent.

6. Shoes Scraping on Backing Plate. Squeaking or "crunch" will

be produced if contact surfaces are dry, rusty or rough. The noise is more pronounced if brake shoes have considerable movement due to large clearance between shoes and drums. Clean, smooth up and lubricate contact surfaces and reduce shoe movement by adjusting to safe minimum clearance (par. 50-9).

7. Shoes Slapping Against Backing Plate. If drums have been returned with a noticeable lead, shoes tend to follow lead and produce a regular slapping noise against backing plate during brake application. Polishing drums with light emery cloth will reduce noise.

#### **i. Brakes Fade (Fail to Hold)**

The condition known as "fade" is caused by loss of friction between brake lining and drums as a result of abnormally high lining temperatures. Excessive heat cooks out the most volatile ingredients of the bonding material in lining and this acts as a lubricant.

Excessive lining temperatures will be produced by partial or spotty contact of linings with brake drums due to improper adjustment. Excessive lining temperature also can be caused by frequent and heavy braking at high speed, driving with parking brakes partially applied, "riding" the brake pedal or prolonged use

of brakes on steep grades without using lower range to obtain adequate engine braking.

After a set of brakes have faded a few times, it is probable that they will continue to fade even though the shoes have been adjusted to establish full contact of linings with drums. This is because the cooking out of bonding ingredients have destroyed the frictional properties of the lining surfaces. If the lining thickness is ample and the cooking process has not been prolonged, it may be possible to obtain a correction and some useful life by grinding off about .020" from the lining. Merely sanding off the lining surface will not remove destroyed lining material. If this cannot be done, replacement of lining is the only remedy.

The use of improperly compounded linings will also produce fade. Some replacement linings lose their frictional properties at lower temperatures than the linings selected for Buick brakes. Such linings must be replaced.

When brake drums are rebored more than maximum allowance (12.080"), they will have excessive expansion due to heat. The result is loss of pedal reserve and braking when drums are hot and good brakes when drums are cold. This may be erroneously diagnosed as fade, but fade occurs with ample pedal reserve.