

SECTION B

44000 (SPORTWAGON ONLY)

AUTOMATIC LEVEL CONTROL

CONTENTS

Division	Paragraph	Subject	Page
I		SPECIFICATIONS AND ADJUSTMENTS:	
	45-1	Automatic Level Control Specifications	40-8
	45-2	Trim Adjustment - On Car	40-9
II		DESCRIPTION AND OPERATION:	
	45-3	Description and Operation of Automatic Level Control	40-9
III		SERVICE PROCEDURES:	
	45-4	Removal and Installation	40-13
	45-5	Removal of Compressor, Reservoir and Regulator Valve Assembly	40-14
	45-6	Disassembly of Compressor Assembly	40-15
	45-7	Cleaning and Inspection of Parts	40-18
	45-8	Assembly of Compressor Assembly	40-18
	45-9	Installation of Compressor, Reservoir and Regulator Assembly . .	40-20
IV		TROUBLE DIAGNOSIS:	
	45-10	Quick Check of Automatic Level Control System	40-20
	45-11	Automatic Level Control Test Gage	40-20
	45-12	Compressor Output Test - On Car	40-20
	45-13	Pressure Regulator Test	40-21
	45-14	Height Control Valve Test	40-21
	45-15	Leak Tests	40-22
	45-16	Trouble Diagnosis Chart	40-23

DIVISION I SPECIFICATIONS AND ADJUSTMENTS

45-1 AUTOMATIC LEVEL CONTROL SPECIFICATIONS

a. Tightening Specifications

Use a reliable torque wrench to tighten the parts listed to insure proper tightness without straining or distorting parts. These specifications are for clean and lightly lubricated threads only; dry or dirty threads produce increased friction which prevents accurate measurement of tightness.

Part	Location	Thread Size	Torque Lb. In.
Screw	Compressor Bracket to Skirt	1/4-14	60-72
Nut	Compressor to Bracket	#10-32	25-35
Bolt	Pressure Regulator Valve to Compressor	#10-32	30-40
Nut	Reservoir or Compressor Retaining Bolt	#10-32	25-30
Adapter	Rubber Mount of Compressor Retaining Bolt	#10-32	25-30
Screw	Height Control Valve to Frame	1/4-14	84-120
Screw	Height Control Valve Bracket to Valve	#8-32	15-20
Nut	Overtravel Body to Lever Adjusting	1/4-28 Locking	70-80

b. General Specifications

Compressor, Pressure Regulator Valve and Tank Assembly Two-Stage, Vacuum Actuated
Shocks Delco Superlift Direct Double Acting
Spring Coil

45-2 TRIM ADJUSTMENT—ON CAR

Trim adjustment should be performed with a full fuel tank (or the equivalent in load at the rate of six pounds per gallon of gasoline).

a. Preparation

1. Raise car using drive-on or axle lift hoise.
2. Remove Superlift air supply line at height control valve. See Figure 40-7.
3. Connect male end of Fill Valve Assembly, J-21999, to Superlift air supply line.
4. Inflate Superlifts to 8-15 psi, use tire gage on fill valve to determine pressure. Jounce car to neutralize suspension.
5. Connect test gage to Superlift outlet on height control valve and attach an 80-110 psi air pressure source to test gage. See Figure 40-8.

b. Adjustment

1. Loosen height control valve lever adjusting nut. See Figure 40-9.
2. Hold overtravel body down in exhaust position until air escapes



Figure 40-8—Connect Test Gage to Superlift Outlet

from exhaust port. See Figure 40-10.

3. Slowly move overtravel body toward neutral position and point of minimum air bleed thru exhaust port. Tighten nut to 75 lb. in. With nut tight, a slight continuous air bleed should be noticeable thru exhaust port.

c. Restore System

1. Remove test gage and air pressure source from Superlift outlet on height control valve.
2. Remove Fill Valve Assembly from Superlift air supply line and reconnect line to height control valve. Torque to 70 lb. in.

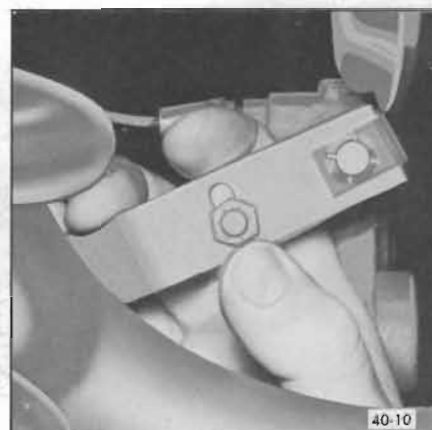

Figure 40-10—Hold Overtravel Body in Exhaust Position

3. Lower car and inflate system through service valve. See Figure 40-11. Load rear suspension and allow car to come to level position. Unload rear suspension, this will put the minimum 8 to 15 psi air pressure in the Superlifts.

DIVISION II**DESCRIPTION AND OPERATION****45-3 DESCRIPTION AND OPERATION OF AUTOMATIC LEVEL CONTROL SYSTEM**

Automatic Level Control, available as a factory or dealer installed

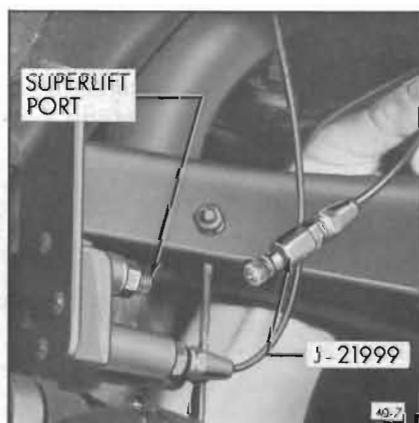

Figure 40-7—Remove Superlift Air Supply Line

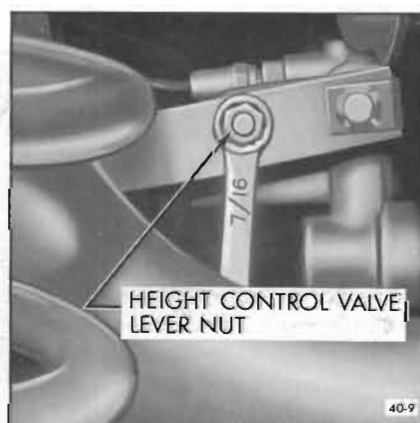

Figure 40-9—Loosen Height Control Valve Lever Nut



Figure 40-11—Filling System Through Service Valve

option on sportwagon, automatically maintains the rear standing height of the car at a nearly constant position regardless of load changes. The system consists of an air compressor, reservoir tank and pressure regulator assembly, height control valve, link, two Superlift rear shocks and flexible air lines. See Figure 40-12.

a. The compressor is a two-stage, vacuum actuated type, requiring no lubrication. Vacuum supply is taken from engine carburetor base. See Figure 40-14. High pressure air is supplied to the reservoir tank by the second stage of the two-stage compressor. The first stage intake stroke draws air at atmospheric pressure through a oneway check valve located in the end of the first stage housing under the first stage housing cover. See Figure 40-15. On the first stage compression stroke, the intake valve is closed and the oneway check valve in the second stage end of the piston is opened. This allows the air from the first stage cylinder to flow through the hollow piston into the second stage cylinder for high pressure compression. See Figure 40-16. The second stage compression stroke closes the check valve in the piston and opens the check valve in the end of the second stage housing. See Figure 40-17.

The intake and compression strokes are controlled by a sliding distributor valve that is actuated through an arm that is tripped by the piston as it nears the end of each stroke. Each time the arm actuates the distributor valve, a different set of holes are covered in the first stage housing. The distributor valve controls the flow of intake manifold vacuum and air under atmospheric pressure, alternately to opposite sides of the compressor diaphragm. See Figures 40-16 and 40-17.

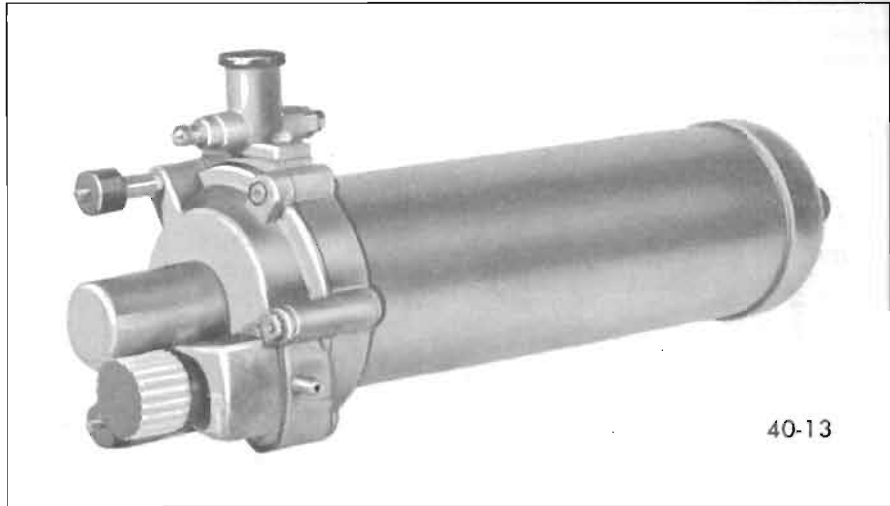

Figure 40-13—Compressor, Reservoir Tank and Regulator Valve Assembly

As the compressor cycles, the reservoir air pressure gradually increases causing a back pressure on the second stage piston until it equals the push of pressure against the diaphragm. At this point, a balanced condition is reached and the unit stops operating. After reservoir pressure drops due to system air usage, the compressor again begins to cycle and replenish the reservoir.

Pressure balance will depend upon the prevailing manifold vacuum and atmospheric pressure. Both are affected by altitude above or below sea level. Balance pressure will vary from approximately 150 to 275 psi.

NOTE: After completion of work on this system or when servicing other parts of the car and the system is deflated, inflate the reservoir to 140 psi or maximum pressure available through the compressor service valve.

b. The pressure regulator valve is preset and limits the reservoir outlet pressure to approximately 125 psi to avoid damage to the height control valve and Superlift shocks. See Figure 40-18.

c. The height control valve, which is mounted on the frame, senses

rear car height through a link attached to the right rear upper control arm. When load is added to the car, the overtravel lever is forced up causing an internal lever to open the intake valve. See Figure 40-19. When this valve is open, high pressure air is admitted to the Superlift shocks. As the car raises to level, the intake valve shuts off.

When load is removed from the car, the overtravel lever is forced down causing the internal arm to open the exhaust valve. As the car lowers to the level position, the exhaust valve shuts off. See Figure 40-21.

A four to fifteen second time delay mechanism, which is built into the height control valve, prevents air transfer due to normal ride movements. The overtravel lever, which pivots around the control valve shaft, rides off the flat side of the control valve shaft and does not have time to react to the rapid changes or normal ride motions. See Figure 40-22.

During changes due to loading, the time delay mechanism will allow the overtravel shaft to open either the intake or exhaust valve as required, since this is not a rapid movement. See Figure 40-23.

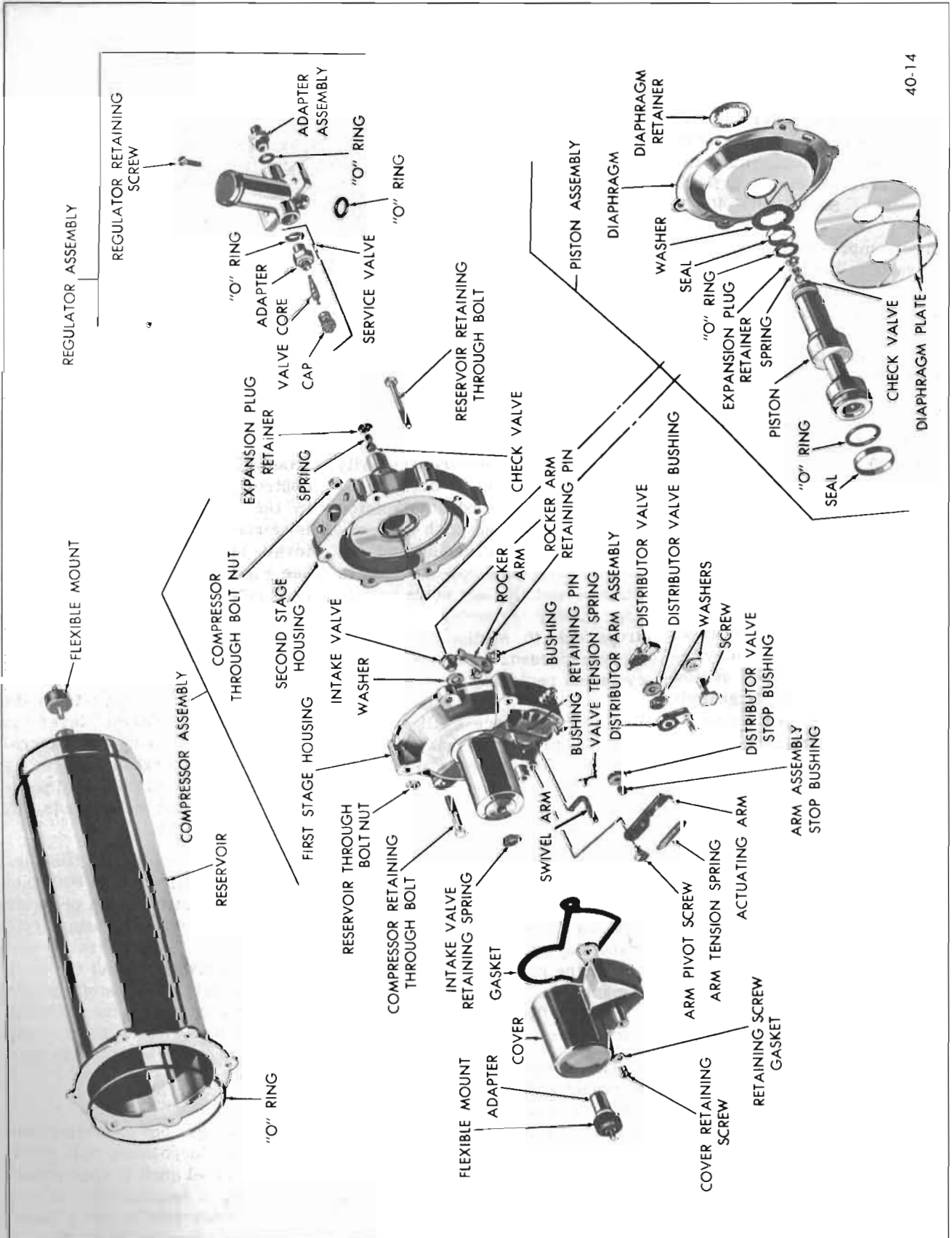

40-14

Figure 40-14—Compressor, Reservoir Tank and Regulator Valve Assembly - Exploded View

d. The Superlift shock absorber is essentially a conventional hydraulic unit with a pliable nylon reinforced neoprene boot acting as an air chamber. See Figure 40-24.

The unit will extend when inflated and retract when deflated by the control valve. One unit is connected to the control valve by a flexible air line. This unit has a second port which is connected by another flexible line to the single port unit on the other side of the car. The crossover line equalizes air pressure in the two Superlifts.

An eight to fifteen psi air pressure is maintained in the Superlift at all times to minimize boot friction. This is accomplished by a check valve in the exhaust fitting on the control valve. Neither shock absorber function nor conventional ride motions thru rear coil springs is impaired in the event of accidental air pressure loss.

e. Flexible air lines are used throughout the system. The line is 1/8" diameter tubing. Each fitting consists of a rubber seal, metal sleeve and nut. See Figure 40-25. These parts are intended

specifically for the 1/8" diameter line and must be used to affect a reliable seal.

NOTE: While the lines are flexible for easy routing and handling, care should be taken not to kink them and to keep them from coming in contact with the exhaust system.

DIVISION III

SERVICE PROCEDURES

45-4 REMOVAL AND INSTALLATION OF TUBING

Tubing may be removed by simply unscrewing nut. Be sure system

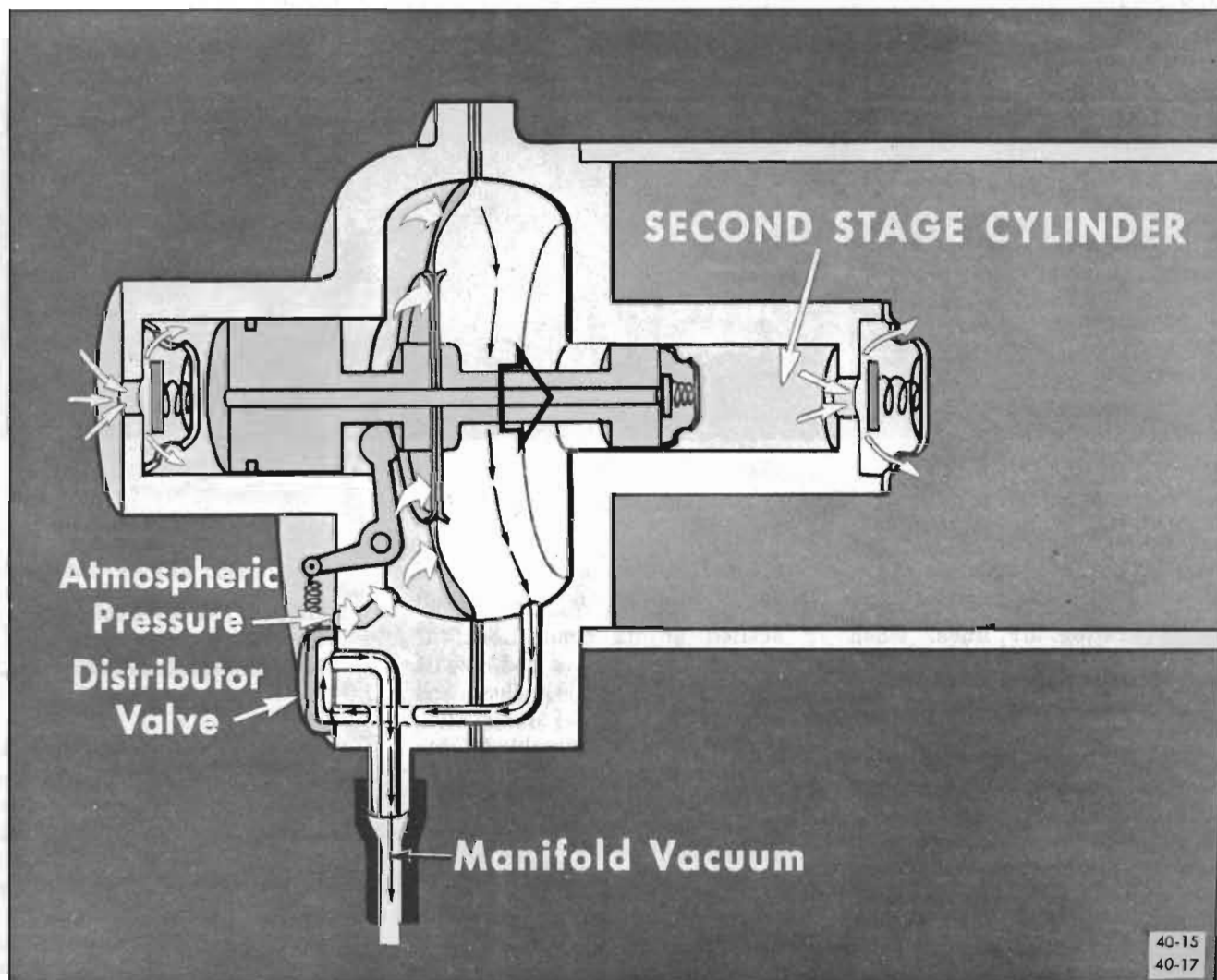

Figure 40-15—First Stage Intake Stroke

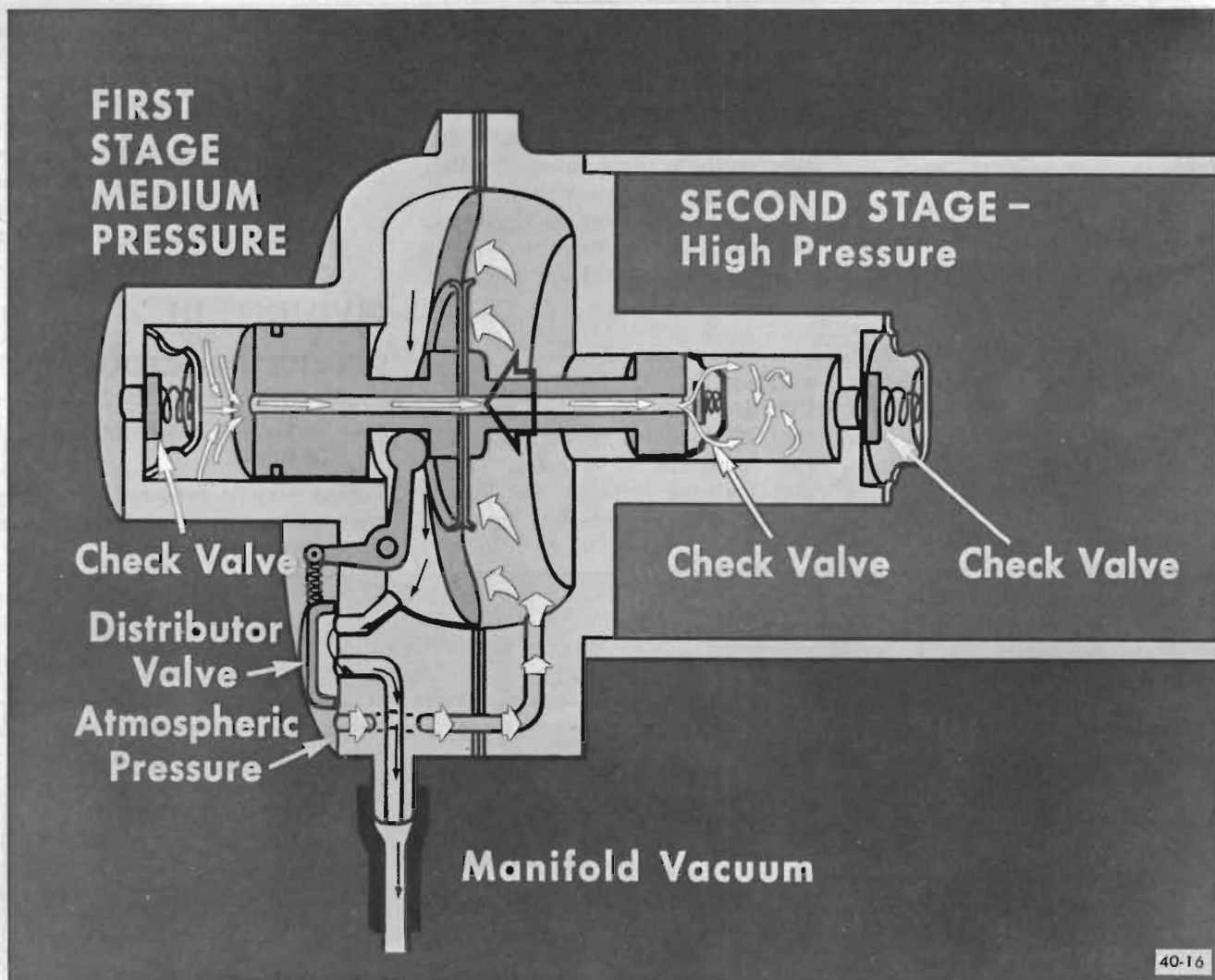

Figure 40-16—First Stage Compression Stroke

is deflated thru service valve before separating air lines. When installing tubing at any Automatic Level Control fitting, be careful not to kink line.

1. Preassemble metal sleeve and rubber seal. See Figure 40-25.
2. Place nut on tubing.
3. Insert tube into metal sleeve and rubber seal until tube bottoms.
4. Holding tubing in bottomed position, tighten tube nut securely (70 lb. in).

NOTE: Tubing may be reinstalled at its connections. If tubing is cracked at end, it will be necessary to cut flush and use a new metal sleeve and rubber seal to assembly as described above. Be careful not to remove too much, or tubing may be kinked or broken at full suspension travel. Care should be taken that proper routing is followed in areas close to the exhaust system to prevent burning the tubing. Note particularly the areas at rear suspension cross member.

45-5 REMOVAL AND INSTALLATION OF COMPRESSOR, RESERVOIR AND REGULATOR VALVE ASSEMBLY

1. Deflate system through service valve.
2. Disconnect high pressure line at pressure regulator valve. Also disconnect vacuum line at compressor.
3. Remove three nuts securing the assembly to the brackets and remove assembly.

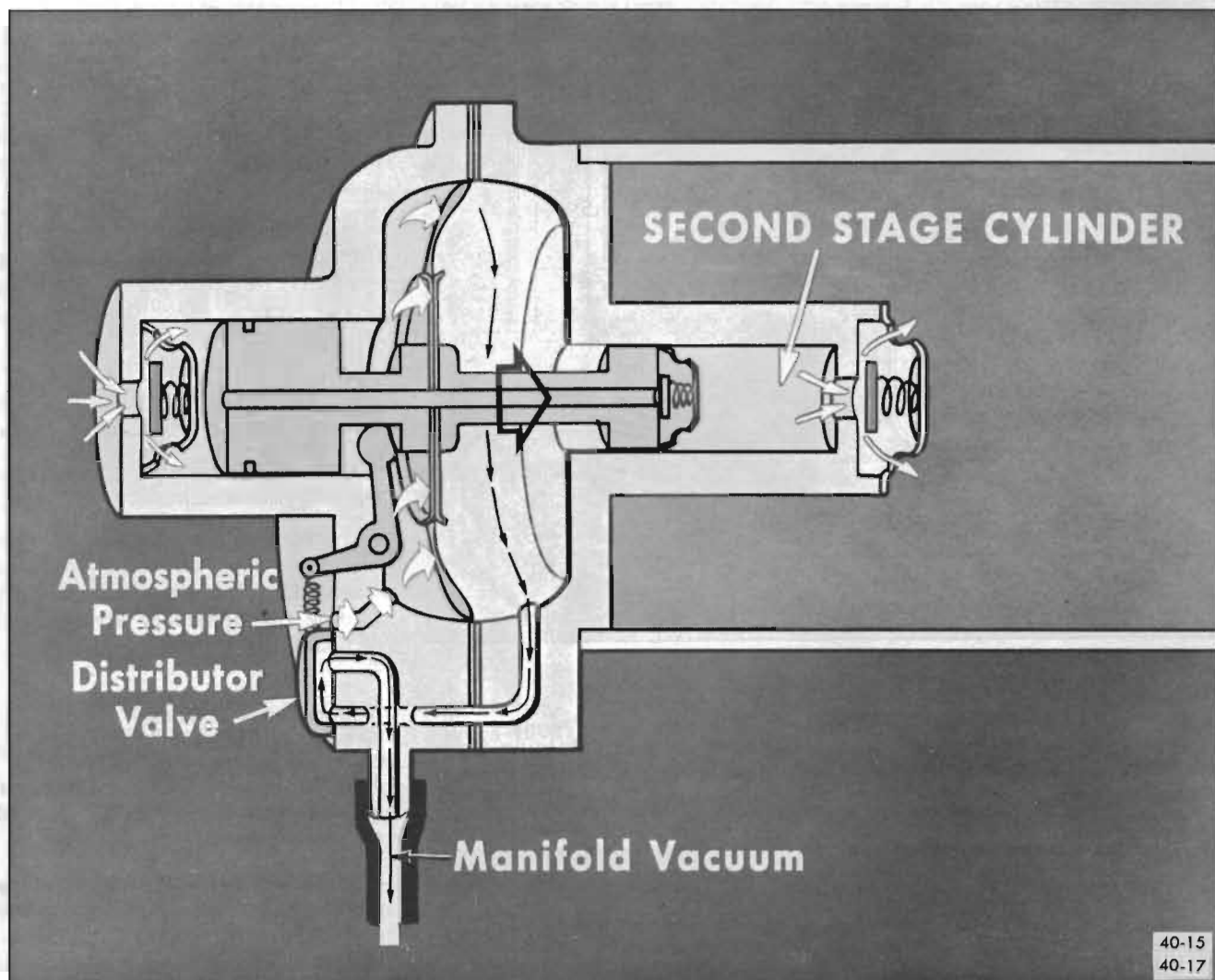

Figure 40-17—Second Stage Compression Stroke

45-6 DISASSEMBLY OF COMPRESSOR ASSEMBLY

a. Disassembly of Compressor into Major Components

The compressor is a precision-built mechanism that should be carefully handled and assembled. Care must be taken to prevent entrance of dirt or other foreign matter. This unit must not be lubricated as it is designed to operate dry.

1. Remove compressor as outlined in paragraph 45-4.

2. Remove two adapters and flexible mounts on compressor end of assembly.

3. Remove nuts from three reservoir retaining (long) bolts. The bolts enter from reservoir flange side of unit.

4. Remove nuts from three compressor retaining (short) bolts. These bolts enter from compressor side of unit.

CAUTION: DO NOT attempt to turn short bolts as they have a second nut hidden between reservoir flange and second stage housing. Always remove nuts

from bolts while holding bolts stationary.

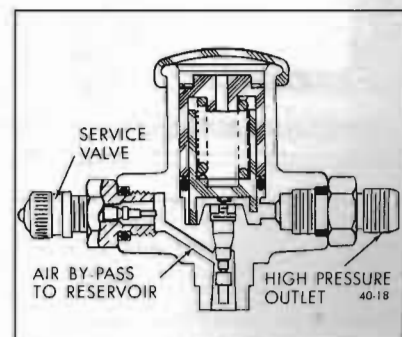

Figure 40-18—Pressure Regulator Valve

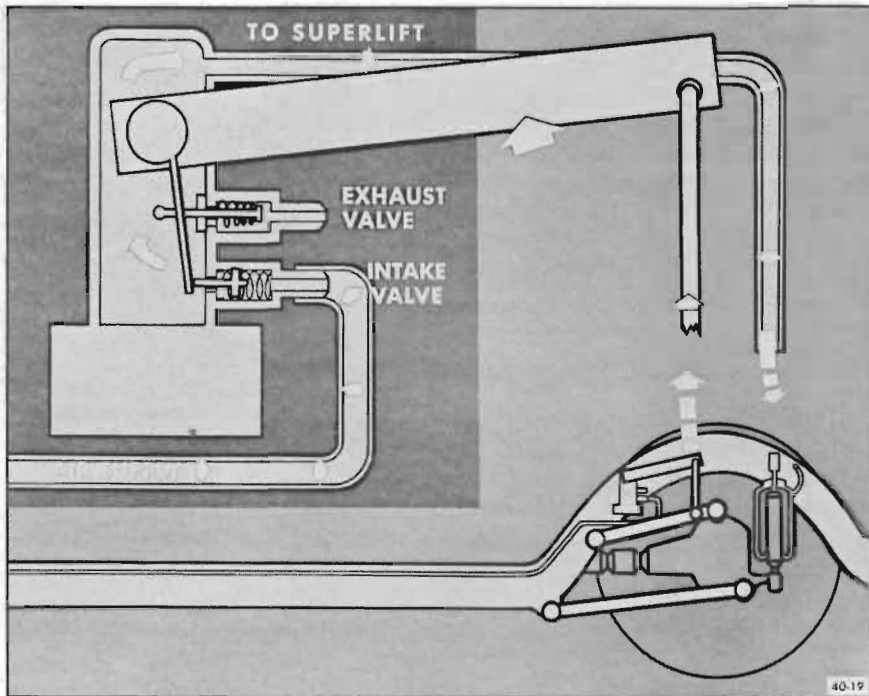

Figure 40-19—Load Added to Car

5. Separate compressor assembly and reservoir. Discard reservoir sealing "O" ring.

6. Remove cover retaining screw. Remove cover and discard cover gasket.

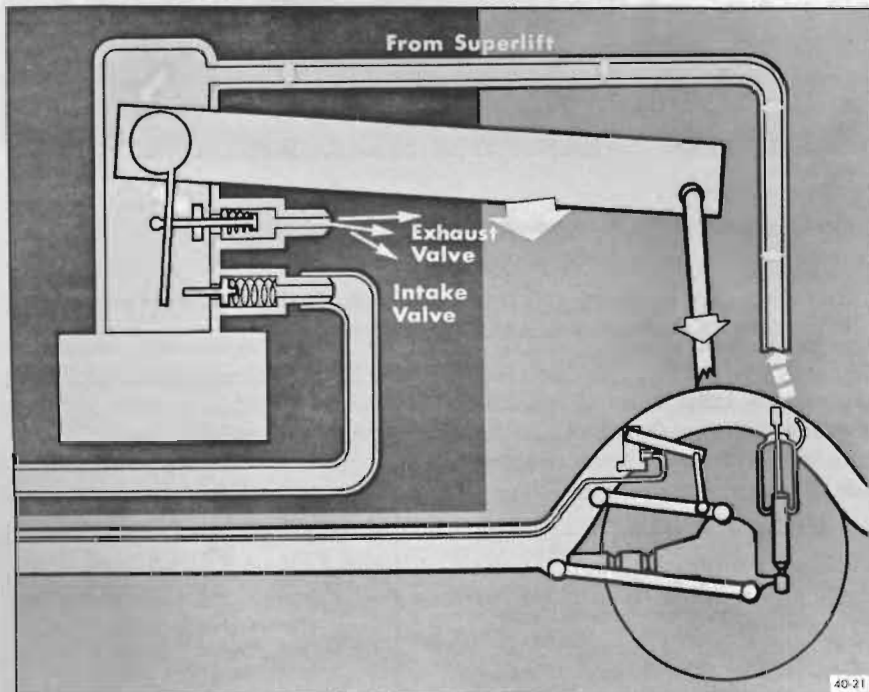

Figure 40-21—Load Removed from Car

7. Remove three compressor retaining (short) bolts that hold first and second stage housings together.

8. Separate first and second stage housings by sliding second stage housing straight off piston.

9. Remove two pressure regulator valve assembly retaining screws. Remove valve assembly from second stage housing and discard "O" ring seal.

10. Disconnect distributor arm tension spring from swivel arm.

11. Remove actuating arm retaining screw and arm.

12. Piston and diaphragm assembly can now be removed from first stage housing by carefully sliding the assembly straight out of housing.

b. Disassembly of Piston— Diaphragm Assembly

1. Remove diaphragm retainer with diagonal pliers and discard retainer. See Figure 40-26.

2. Remove diaphragm plate, diaphragm, second diaphragm plate and corprene washer. The diaphragm and corprene washer can be discarded.

3. Remove and discard piston seals and "O" rings from piston.

CAUTION: Be careful not to damage piston.

4. Remove check valve in second stage end of piston by inserting a suitable punch or piece of 3/32" welding rod through air passage from first stage end and tapping.

c. Disassembly of First Stage Housing and Valve Mechanism

Actuate distributor valve with finger. Valve tension spring should press against distributor valve, holding it against either stop. If valve action is not free and positive, it will be necessary to

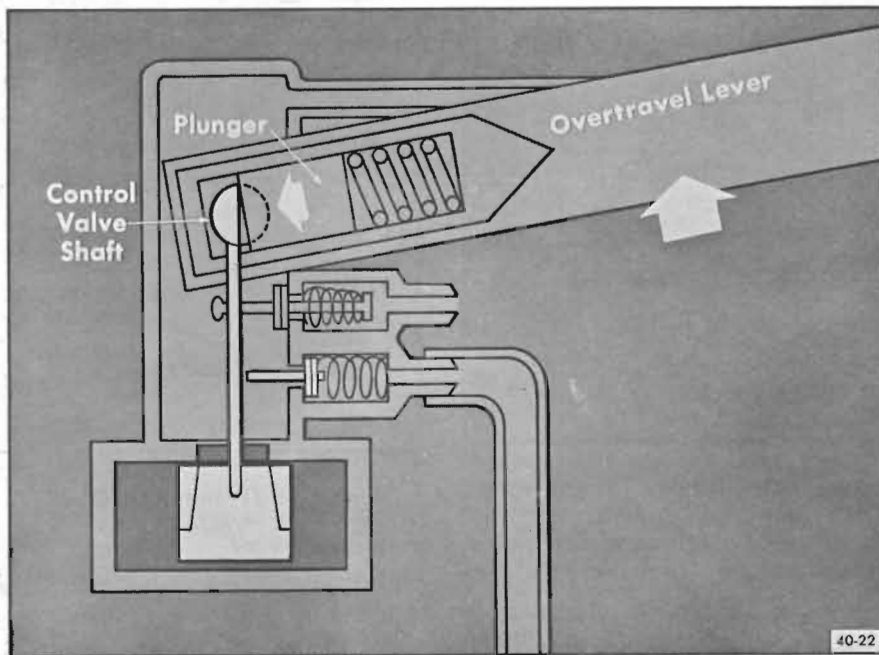

Figure 40-22—Rapid Movement of Overtravel Lever

rebuild using new parts in Distributor Valve and Arm Package. If action is free and positive and upon disassembly there are no damaged parts, parts may be re-used.

1. Remove screw, washer, distributor arm assembly, washer and

distributor valve bushing. See Figure 40-27.

2. Remove two arm assembly stop bushings and two distributor valve stop bushings.

3. Remove distributor valve being careful not to distort valve tension spring.

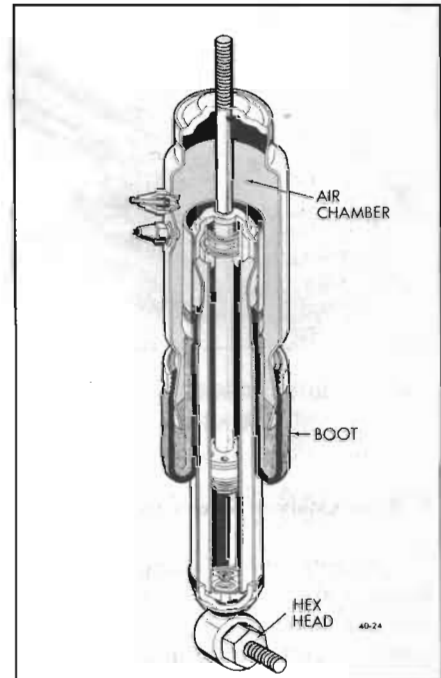

Figure 40-24—Superlift Shock Absorber

4. Carefully remove valve tension spring from boss. Do not distort spring.

NOTE: Tension spring has one short foot and one long foot. The short foot fits under the distributor valve and the long foot fits into a hole drilled at an angle in the boss. See Figure 40-28.

5. Remove intake check valve retaining spring, intake check valve and washer using a socket knife.

6. If necessary, remove rocker and swivel arms. Grip pin with pliers and remove pin. See Figure 40-29.

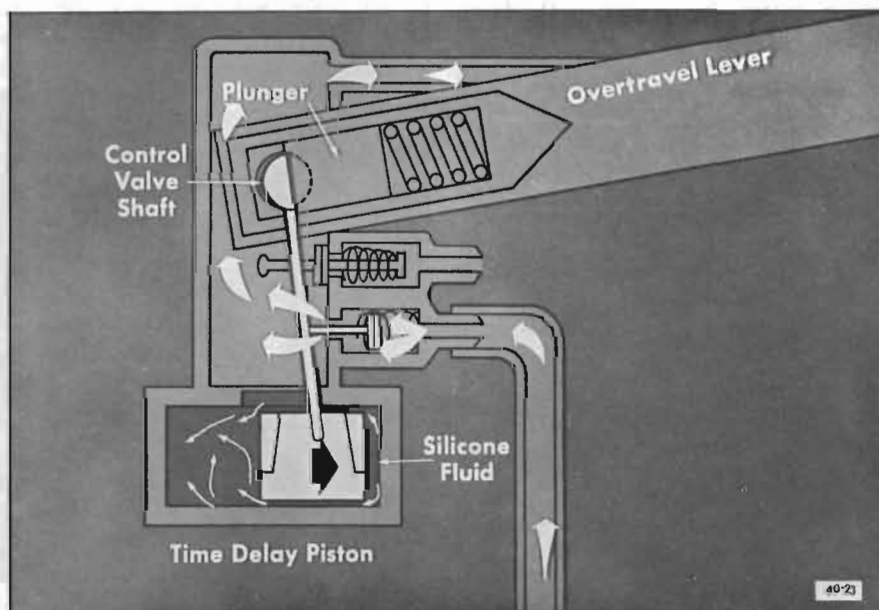

Figure 40-23—Load Movement of Overtravel Lever

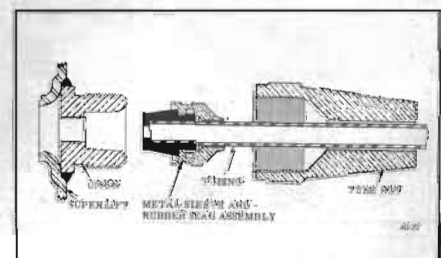

Figure 40-25—Fitting Nut and Seal

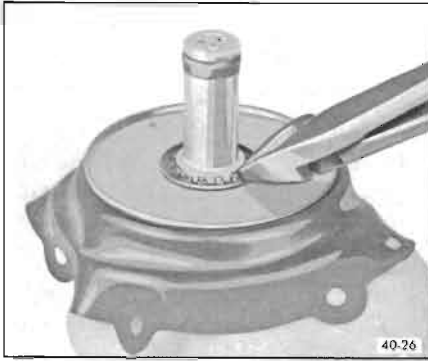

Figure 40-26—Removing Diaphragm Retainer

d. Disassembly of Second Stage Housing

1. Remove check valve in second stage housing by inserting a suitable punch or piece of 3/32" welding rod through air passage and tapping.

45-7 CLEANING AND INSPECTION OF PARTS

All metal parts should be cleaned in clean solvent and blown dry with compressed air.

a. Piston and Diaphragm Assembly

1. Inspect piston for scoring, replace if necessary.
2. Inspect check valve seat. Seat should be smooth and clean.

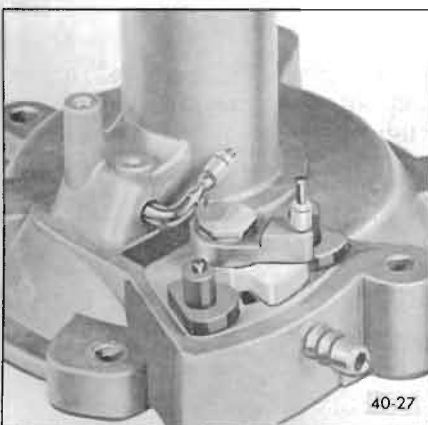

Figure 40-27—Removal of Distributor Valve

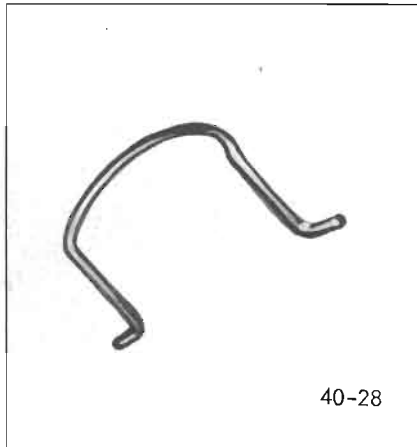

Figure 40-28—Valve Tension Spring

3. Inspect diaphragm for holes, looseness or other defects, replace if necessary.

b. First Stage Housing and Valve Mechanism

1. Inspect housing for cracks or damage and replace if necessary.
2. Inspect piston bore, replace housing if scored.
3. Inspect check valve seat. Seat should be smooth and clean.
4. Inspect distributor valve parts for wear and replace if necessary.
5. Inspect distributor valve seat on housing for wear. Replace housing if necessary.

c. Second Stage Housing

1. Inspect piston bore, replace housing if scored.

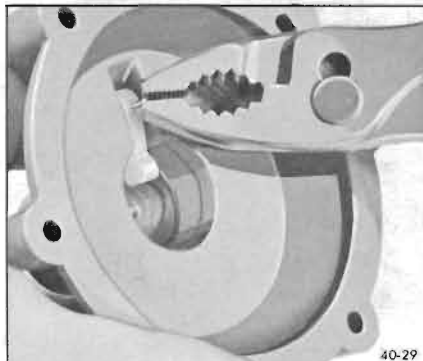

Figure 40-29—Removing Rocker Arm Pin



Figure 40-31—Installing Check Valve

2. Inspect check valve seat. Seat should be smooth and clean.
3. Inspect housing for cracks or damage and replace if necessary.

45-8 ASSEMBLY OF COMPRESSOR ASSEMBLY

a. Assembly of Second Stage Housing

1. Install new check valve and spring.

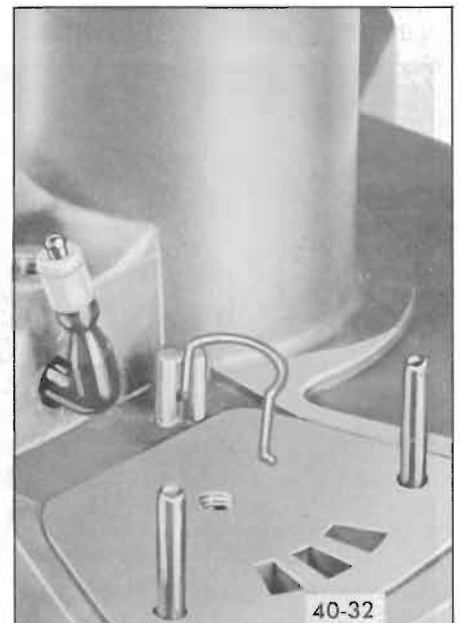

Figure 40-32—Installing Valve Tension Spring in Boss

2. Insert new expansion plug retainer and tap in until it bottoms. See Figure 40-31.

b. Assembly of First Stage Housing and Valve Mechanism

1. If removed, position bushings in first stage housing and install rocker arm and swivel arm. Align holes in rocker and swivel arms and install retaining pin, small end first.

NOTE: If distributor mechanism failed to operate properly or one or more parts were found defective, use new parts in Distributor Valve and Arm Package during remaining reassembly.

2. Install washer on intake valve and install in first stage housing with intake valve retaining spring.

3. Install longer foot of valve tension spring in boss on first stage housing being careful not to distort spring. See Figure 40-32.

4. Position distributor valve so that short foot of tension spring fits under valve and vertical leg is in slot. See Figure 40-33.

5. Install distributor valve bushing, washer, distributor arm assembly, washer and secure with screw. Tighten to 12 lb. in. See Figure 40-34.

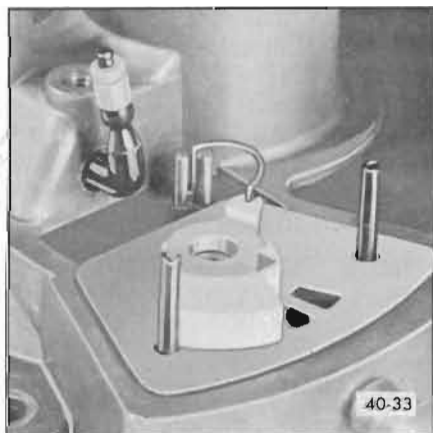

Figure 40-33—Positioning Distributor Valve



Figure 40-34—Installing Distributor Arm Assembly

6. Install two distributor valve stop bushings and two arm assembly stop bushings.

NOTE: Do not install actuating arm, arm tension spring or arm pivot screw at this time as rocker arm must be free to permit entrance of piston into first stage housing.

c. Assembly of Piston—Diaphragm Assembly

1. Install new corprene washer, old plate (unless damaged), new diaphragm (with outer lip toward second stage end of piston) and second plate. See Figure 40-35.

2. Using a 13/16 inch deep socket as a retainer installer, press against the piston shoulder on the

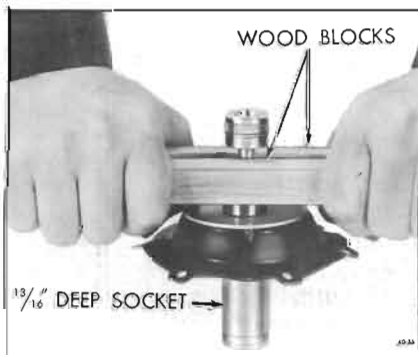

Figure 40-35—Installing Diaphragm Retainer

first stage housing side with wood blocks to seat retainer. The wood blocks used in the illustration are each 3/4" x 3/4" x 12".

NOTE: Be sure retainer is securely seated in order to affect an air tight seal against the corprene seal.

3. Install new "O" rings by rolling into groove. Relieve any resulting twist.

4. Install new seals using a piece of .020" shim stock. See Figure 40-36.

CAUTION: Make sure shim stock has no sharp edges that may cut seal. Do not stretch seal more than is necessary to install. Seals must be installed so they are not twisted.

d. Assembly of Major Components

1. Slide piston assembly straight into first stage (large diameter) housing.

2. Install actuating arm and secure to first stage housing with arm pivot screw. Tighten to 12 inch lb.

3. Connect arm tension spring to swivel arm.

4. Rotate piston in first stage housing to align elongated hole in diaphragm with vent port in housing.

5. Install second stage housing by sliding straight onto second stage piston.

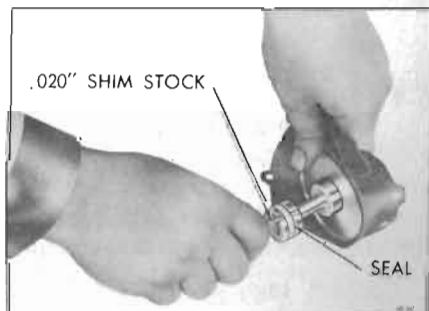

Figure 40-36—Installing Piston Seal

6. Install three compressor retaining (short) bolts from the first stage housing side, through the second stage housing hex shaped, recessed holes. The first and second stage housings will align one way only. Position three small nuts in hex recesses and tighten bolts to 28 lb. in.

7. Install new "O" ring on second stage housing. Install reservoir on second stage housing with three large nuts. Tighten to 28 inch lb. Install the two reservoir retaining* (long) bolts, from reservoir side, that do not go through cover. Tighten to 28 lb. in.

8. Install new gasket and cover and secure with retaining screw. Tighten screw to 35 inch lb. Install third reservoir retaining (long) bolt. Tighten to 28 lb. in.

9. Install new "O" ring on pressure regulator and secure with two retaining screws with high pressure fitting toward reservoir. Tighten to 35 lb. in.

10. Install two adapters and flexible mounts on the two reservoir (long) bolts that do not go through cover. Tighten to 28 lb. in.

11. Compressor should be output tested before installation on car. See Division IV, Compressor Output Test on Car.

12. If compressor passes output test, install Compressor, Reservoir and Regulator Valve Assembly on car.

45-9 INSTALLATION OF COMPRESSOR, RESERVOIR AND REGULATOR VALVE ASSEMBLY

1. Install assembly in brackets and tighten nuts to 30 lb. in.
2. Connect high pressure line to regulator valve and tighten fitting nut to 70 lb. in. Install vacuum line to compressor.

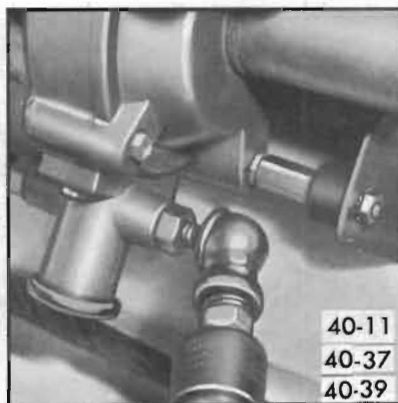

Figure 40-37—Filling System Through Service Valve

3. Inflate system through service valve to maximum available pressure. See Figure 40-37.

NOTE: If available pressure is less than 140 psi, start engine to build up reservoir to this pressure.

DIVISION IV

TROUBLE DIAGNOSIS

45-10 QUICK CHECK OF AUTOMATIC LEVEL CONTROL SYSTEM

1. Record rear trim height of empty car (measure from center of rear bumper to ground).
2. Add weight equivalent to two passenger load to rear of car. Car should begin to level in 4-15 seconds. Final position should be within $\pm 1/2$ inch of original measurement.
3. Remove weight. Car should begin to settle in 4-15 seconds. Final position should be within $\pm 1/2$ inch of original measurement.

45-11 AUTOMATIC LEVEL CONTROL TEST GAGE

To properly service the Automatic Level Control, it will be necessary to obtain Test Gage

J-22124 or equivalent. A test gage can be made up by collecting and assembling the following parts.

a. Parts Required

1. Fill Valve, J-21999 (two per package).
2. A tee which has three 1/8" female taper pipe threads.
3. One adapter which has a 1/4" female taper pipe thread on one end and a 1/8" male taper pipe thread on the other end.
4. Air Pressure Gage J-6840-1.
5. One male connector which has a 1/8" male taper pipe thread on one end and a 3/8"-24 straight thread male thread on the other end.
6. Two metal sleeves, rubber seals and tube nuts.
7. A length of 1/8" tubing.

b. Assembly

1. Install adapter in tee.
2. Install connector in one end of tee.
3. Install Fill Valve, J-21999, in other end of tee.
4. Install Pressure Gage, J-6840-1, in adapter.
5. Install fitting nut on tubing, then install metal sleeve and rubber seal over end of tubing until tubing bottoms in rubber seal. Tubing, nut and seal assembly can now be installed on connector opposite the fill valve. Tighten fitting nut to 70 inch lb.

NOTE: Make certain all fittings are air tight.

45-12 COMPRESSOR OUTPUT TEST—ON CAR

1. With all engine operated accessories turned off and ignition

turned off, deflate system through service valve. Remove high pressure line at regulator and connect test gage.

2. Inflate reservoir to 70 psi through service valve.

3. Observe test gage for evidence of compressor air leak.

4. If leaking, proceed to leak test the compressor, reservoir and regulator as outlined in paragraph 45-14. If not leaking, continue with this test.

5. With engine running at slow idle, observe reservoir build-up for five minutes. Reservoir pressure should build up to a minimum of 90 psi.

6. If compressor fails to cycle, make sure the vacuum line and filter is open and unobstructed before removing compressor for repair.

7. If build-up is too slow, proceed to repair compressor as outlined in Division III.

8. Satisfactory build-up indicates system problem to be in the control section. See paragraph 45-13. However, again observe the test gage for evidence of an air leak and proceed accordingly.

45-13 PRESSURE REGULATOR TEST

Performance test the regulator with a known good compressor on the car.

1. Deflate system through service valve and disconnect line at pressure regulator valve. Install test gage on regulator valve high pressure fitting. See Figure 40-38.

2. Inflate system through service valve to maximum available pressure. See Figure 40-39.

NOTE: If available pressure is less than 140 psi, start engine to build-up reservoir to this pressure.

3. Regulated pressure should



Figure 40-38—Test Gage Installed on Regulator Valve

build-up to and hold steady at 100-130 psi on test gage.

4. Check regulated pressure by momentarily (not more than one second) depressing valve core on test gage and observe gauge reading.

5. If regulated pressure now reads less than 100 psi, replace regulator assembly.

6. If regulated pressure exceeds 130 psi, replace regulator assembly.

45-14 HEIGHT CONTROL VALVE TEST

a. Exhaust (Superlifts Inflated)

1. Disconnect overtravel lever from link.

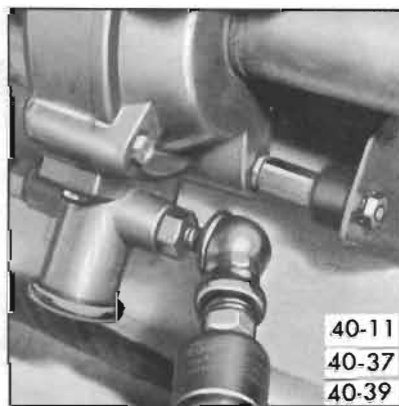

Figure 40-39—Filling System Through Service Valve

2. Hold lever down in exhaust position until Superlifts deflate or for a minimum of 15 seconds.

3. If Superlifts deflate, perform Intake Check.

4. If Superlifts do not deflate, remove exhaust adapter from control valve and hold lever down as in Step 2. Replace adapter, "O" ring and filter if this deflates Superlifts.

5. Replace control valve if none of the above steps corrects problem.

b. Intake (Reservoir Pressure 125 psi Minimum)

1. Disconnect overtravel lever from link.

2. Hold lever up in intake position until Superlifts inflate or for a minimum of 15 seconds.

3. If Superlifts inflate and hold, proceed to Time Delay Check.

4. If Superlifts inflate and then leak down, perform leak test on lines and fittings and then on Superlifts, paragraph 45-14, subpar. c. Also check and, if necessary, replace intake and Superlift screens and "O" rings. If Superlifts still do not inflate, perform leak test on valve, paragraph 45-14, subpar. b. Repair as indicated and proceed to time-delay check.

c. Time Delay Check

1. Disconnect overtravel lever from link.

2. Disconnect lines at Superlift and intake ports.

3. Connect test gage to intake valve port and open air pressure (95 psi). Move overtravel lever approximately one inch down from neutral position as measured from end of lever.

4. Quickly move overtravel lever upward two inches; at the same

time, begin timing number of seconds before air starts to escape from Superlift port. This delay should be from 4-15 seconds. Repeat check. This will check the air intake time delay. Proceed with check to determine air exhaust time delay.

5. Remove test gage and plug intake port with Fill Valve J-21999.

6. Connect test gage to Superlift port and open air pressure (95 psi). Move overtravel lever approximately one inch up from neutral position as measured from end of lever.

7. Quickly move overtravel lever downward two inches; at the same time, begin timing number of seconds until air begins to escape from exhaust port. This delay should be 4-15 seconds. Repeat check.

If either delay is not within specification, there has either been a loss of silicone fluid or valve has lost its adjustment due to damage or wear. Valve must be replaced.

45-15 LEAK TEST

a. Compressor, Reservoir and Regulator

1. Remove assembly intact.
2. Connect test gage to regulator. Inflate reservoir through service valve to 80-110 psi.
3. Route an 8" piece of rubber hose between vacuum and vent ports. See Figure 40-41.
4. While holding assembly in a vertical position with reservoir end down, immerse in water until diaphragm is just submerged. Do not submerge completely, as water can enter around the cover gasket. Observe for air leaks at:

Reservoir weld seam.

Reservoir to compressor "O" ring. A stream of bubbles may appear in this area and then cease. The bubbles are caused by atmospheric air being purged from air pockets in the second stage housing. If the bubbles stop, there is no leak.

Regulator to compressor "O" ring.

Regulator boot--defective internal "O" ring.

Diaphragm between first and second stage housings--tightening through-bolts may correct the leak.

Service valve.

Test gage connections.

5. Remove hose from vacuum port and submerge disconnected end in water. Cover vacuum port with finger. Do not permit water to enter through vacuum port. If bubbles are evident, the probable cause is a defective second stage housing check valve.

6. Correct any leaks by either tightening screws or replacing parts.

7. If the cover gasket area is inadvertently submerged, remove cover and tilt unit so that water may drain through openings by distributor valve mechanism. Move distributor valve from side to side until all water is purged. Blow dry with compressed air, both the distributor valve mechanism and interior of the cover. Replace cover.

If the compressor passes this test, yet fails the output test, the compressor, reservoir and regulator need to be overhauled.

b. Control Valve

1. Remove control valve from car.
2. Clean exterior of control valve thoroughly.
3. Connect test gauge and air pressure source to intake adapter and open air pressure (80-110 psi).
4. Submerge unit in water. No air should escape if overtravel lever is in "neutral" position. If bubbles escape from Superlift port, replace control valve.

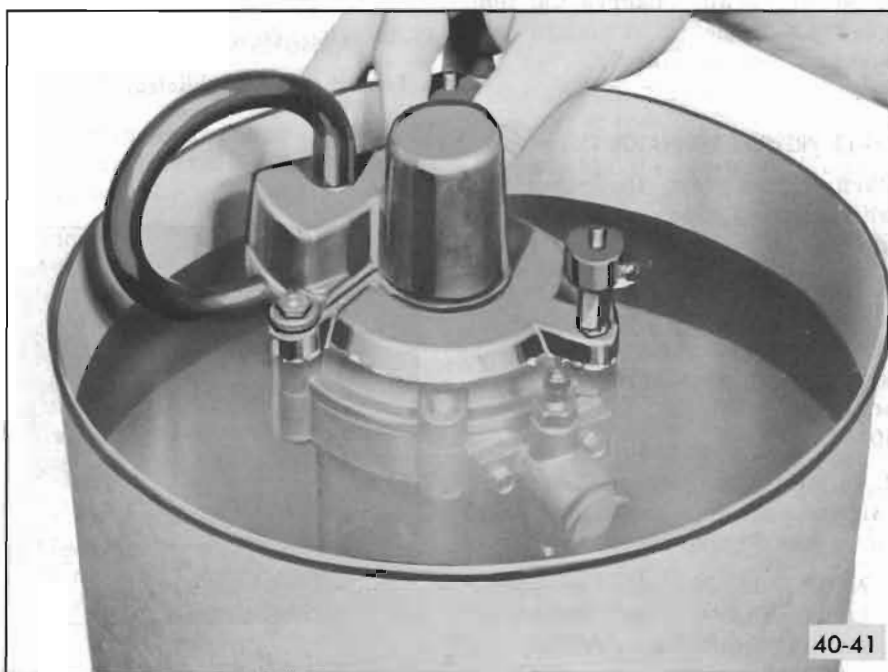

40-41

Figure 40-41—Checking Compressor, Reservoir and Regulator for Leaks

5. Shut off air pressure and detach test gage from air intake port. Plug intake port with Fill Valve, J-21999.

6. Connect test gage to Superlift port and open air pressure.

7. With overtravel lever in "neutral" position, no air should escape. If bubbles escape from exhaust port, replace control valve.

8. If air escapes around edge of cover plate, the gasket must be replaced.

9. Remove control valve from water. Actuate overtravel lever to expel any water from unit.

10. Shut off air pressure and remove line from Superlift port.

c. Lines and Fittings

1. Disconnect overtravel lever from link.

2. Hold lever up in intake position for maximum Superlift inflation and release.

3. Leak check all connections with a soap and water solution.

d. Superlifts

1. Disconnect lines and remove Superlift from car.

2. Inflate individually to 50-60 psi utilizing Fill Valves J-21999, submerge in water and observe for leaks.

3. Install Superlifts and connect lines.

45-16 DIAGNOSIS CHART

CONDITION	CAUSE	CORRECTION
Car loaded, will not raise.	External damage or breakage. Line leak. Control valve setting incorrect. Defective component.	Visually inspect - Lines Link Control valve Superlifts Leak Test - Lines and fittings. Perform trim adjustment on car. Perform system test and proceed as indicated.
Car loaded. Raises to level and then leaks down.	Line leak. Control valve exhaust leak. Superlift leak. Control valve leak.	Leak test lines and fittings from control valve to Superlifts and crossover line. Control valve test - on car. Leak test Superlifts. Leak Test - Control Valve Off Car.
Car loaded, raises partially.	Load excessive (over 500 lbs. at axle) on cars with special springs. Control valve setting incorrect. Low supply pressure.	Distribute load, shift forward if practical. Perform trim adjustment on car. Perform compressor output test on car.
Car unloaded, rides too high, will not come down.	Control valve setting incorrect.	Perform trim adjustment on car.

45-16 DIAGNOSIS CHART (Cont'd)

CONDITION	CAUSE	CORRECTION
Car Unloaded (Cont'd.)	External damage or breakage. Defective control valve.	Visually inspect - Lines Link Control Valve Superlifts Control valve test.
Car rises when loaded but leaks down while driving.	Time delay mechanism not functioning properly.	Check time delay mechanism.