

SECTION A

43-44000 FRAME AND BODY MOUNTINGS

CONTENTS

Division	Paragraph	Subject	Page
I	20-1	SPECIFICATIONS AND ADJUSTMENTS: Body Mount Specifications	20-2
II	20-2	DESCRIPTION AND OPERATION: Description of Body Mounts	20-2
III	20-3	SERVICE PROCEDURES: Removal and Installation of Body Mounts	20-2
IV	20-4	TROUBLE DIAGNOSIS: Trouble Diagnosis	20-3

DIVISION I SPECIFICATIONS AND ADJUSTMENTS

20-1 BODY MOUNT SPECIFICATION AND ADJUSTMENT

The 1966 body mount material is new and should not be inter-mixed with previous model parts.

See diagrams for correct installation and torque specifications.

DIVISION II DESCRIPTION AND OPERATION

20-2 DESCRIPTION OF BODY MOUNTS

The body of the car is mounted to the chassis by means of thick rubber mounts. These mounts are

specifically designed for each location to give the maximum amount of structure rigidity while at the same time providing optimum road noise isolation. Two basically different mounts are used for this purpose. At those locations where a bolt is used, the mounting consists of a load carrying mount which rests on top of the frame side rails or mounting brackets, a metal tube spacer which limits the amount of compression of the mount and an insulator which fits on the bottom side of the frame side rail surface. All bolt-in body mounts have a specified bolting torque.

The second type of body mount used is of a plug-in design and has no mounting bolt. This mount plugs into a mounting hole on top of the frame side rail or rear spring seat and acts as a steady rest for the body.

DIVISION III SERVICE PROCEDURES

20-3 REMOVAL AND INSTALLATION OF BODY MOUNTS

The removal of any one body mount necessitates the loosening of adjacent body mountings to permit the frame to be separated from the body.

During installation of a body mount, caution should be used to insure that the body mount is properly seated in the frame mounting hole, otherwise a direct metal to metal short circuit will result between the frame and body. The tube spacer should be in all bolt-in body mounts and the insulator and metal washer positioned to prevent the washer from contacting the frame side rail. Do not use lubricants of any

kind on the rubber parts of the mounts. Proper clamping by the mount depends on clean and dry surfaces. Do not over-torque the body mount or a collapsed tube spacer or stripped bolt will result. Lubricating the bolt threads will result in a higher clamping force for the same torque setting. If the body mount bolt does not screw in smoothly, it may be necessary to run a tap through the cage nut in the body to remove

foreign material. If caution is not observed, broken body mount bolts may result.

DIVISION IV

TROUBLE DIAGNOSIS

20-4 TROUBLE DIAGNOSIS

Improper body mount installations

may result in the following problems:

1. Structure shake
2. Road noise
3. Squeaks

The above problems can sometimes be caused by the wrong part being installed or the mount not being properly torqued.

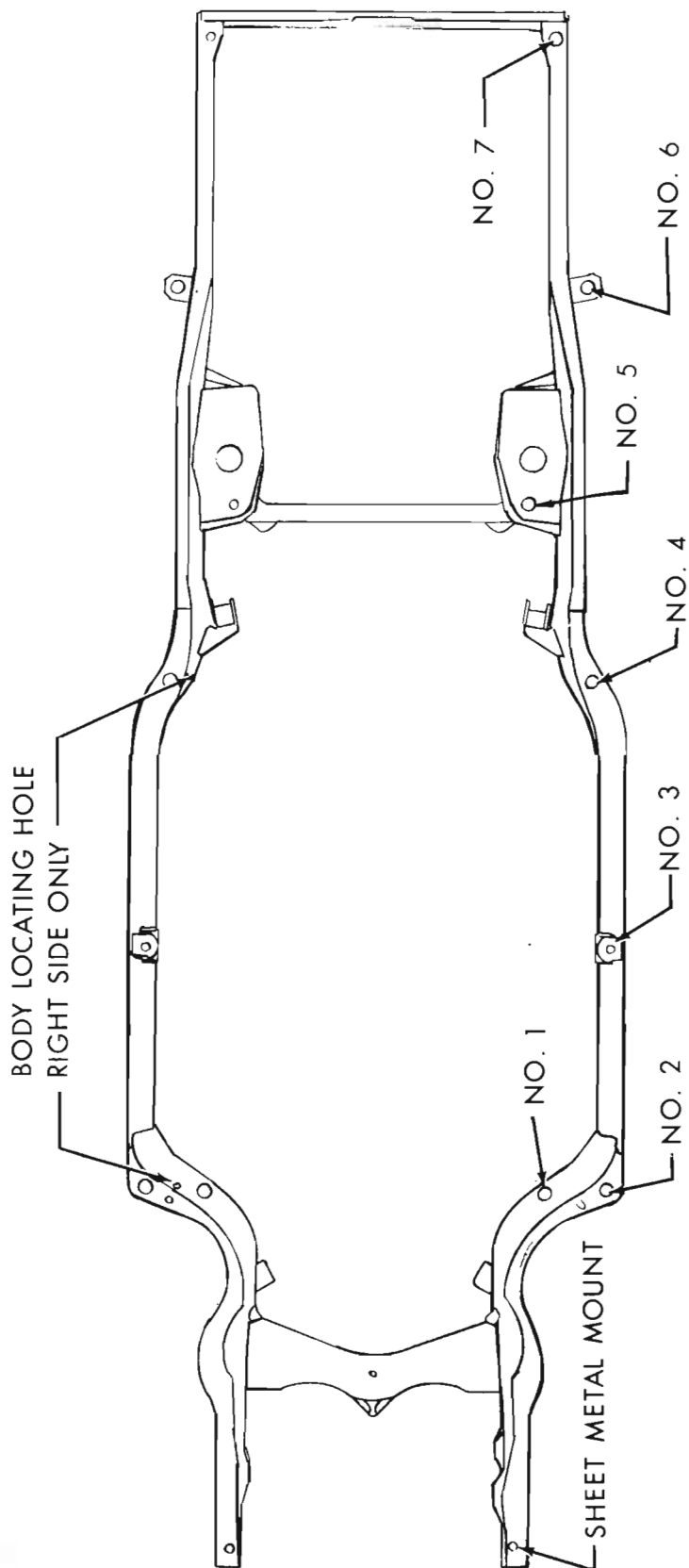

20-1

Figure 20-1 43-44000 (Less Sport Wagon) Frame

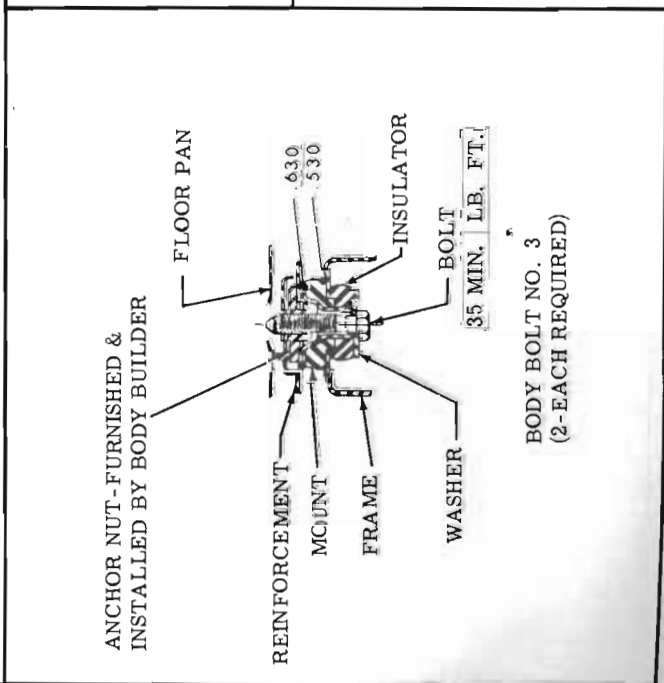
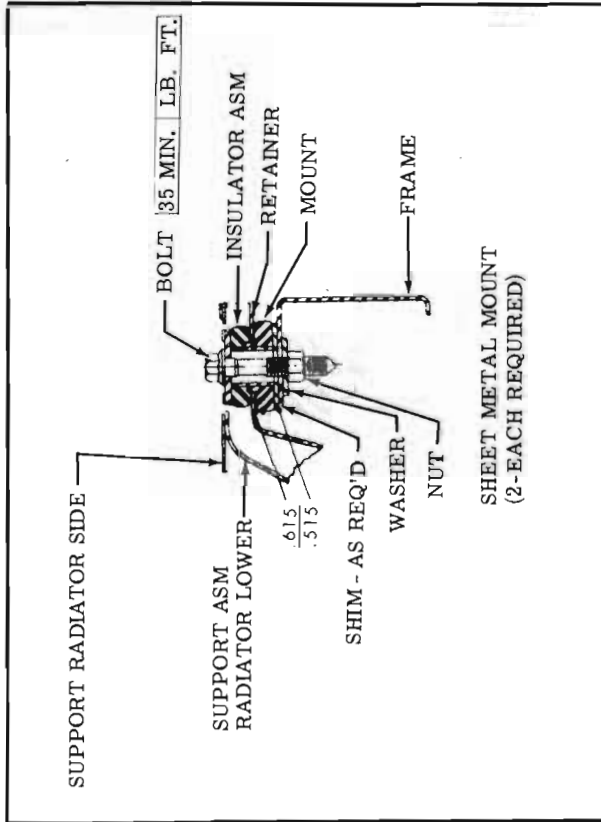
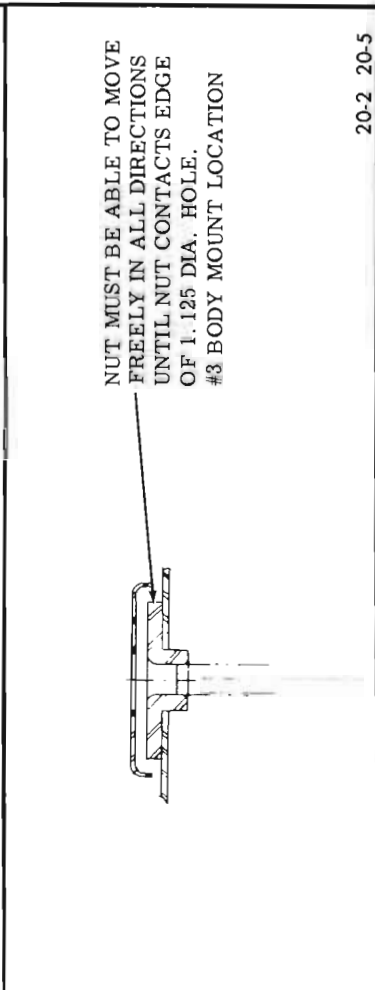
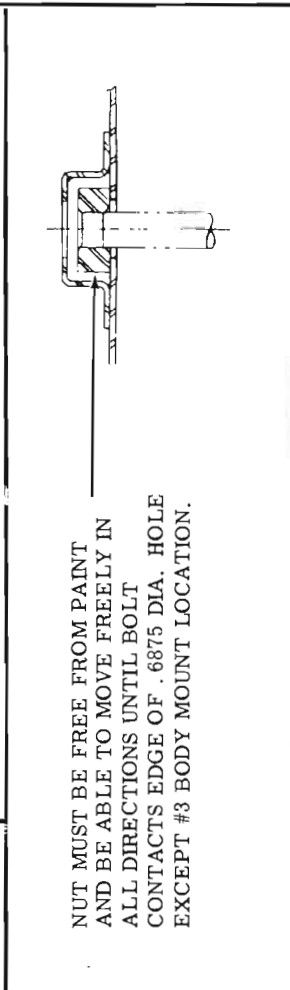
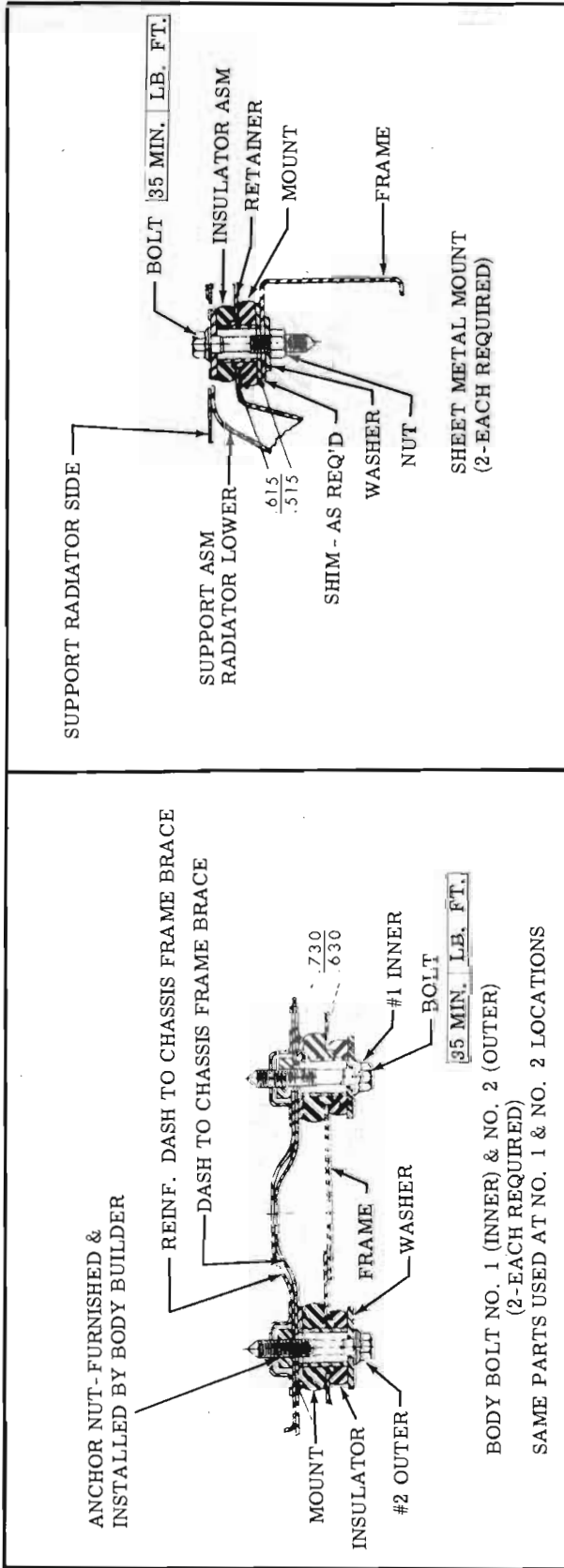

20-2 20-5

Figure 20-2 43-44000 (Less Sport Wagon) Body Mounts

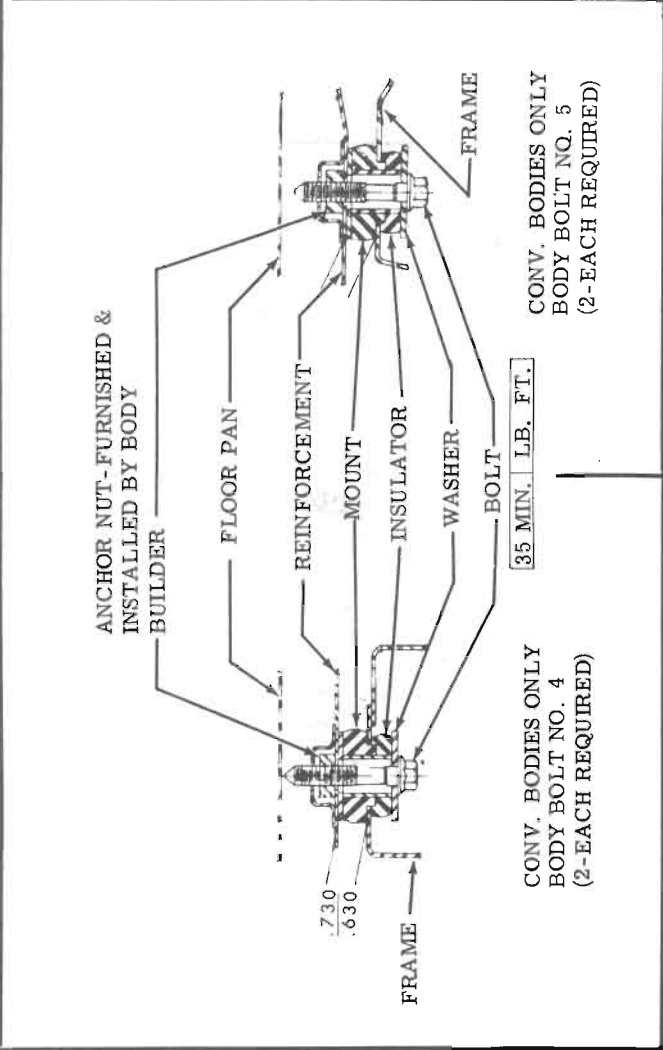
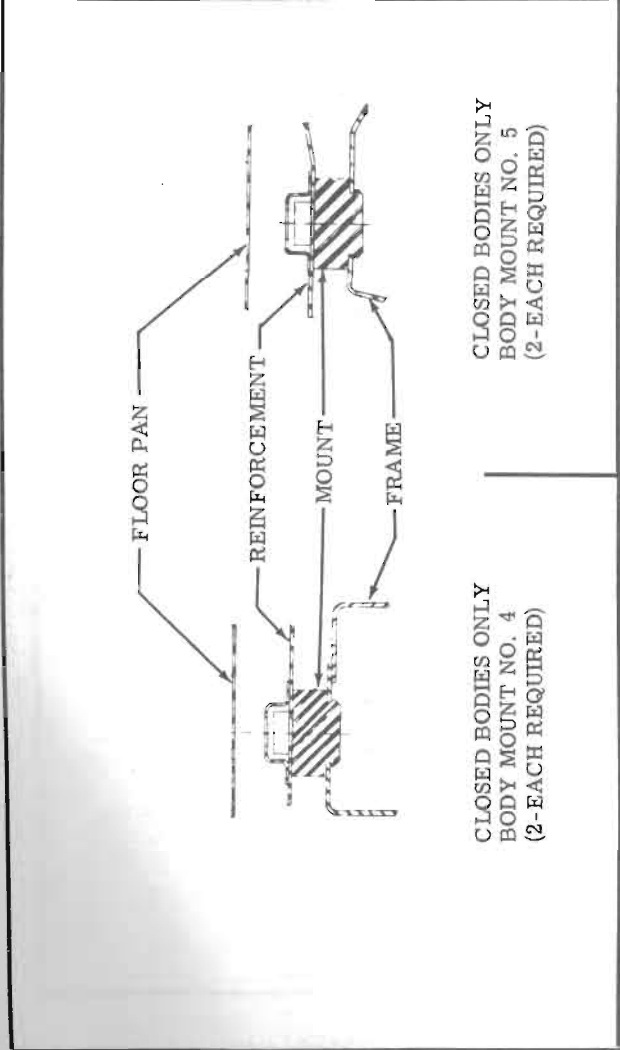
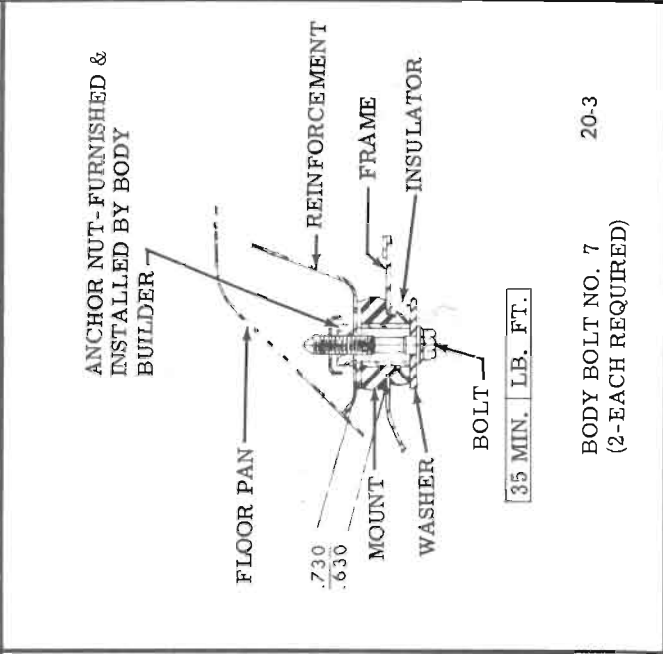
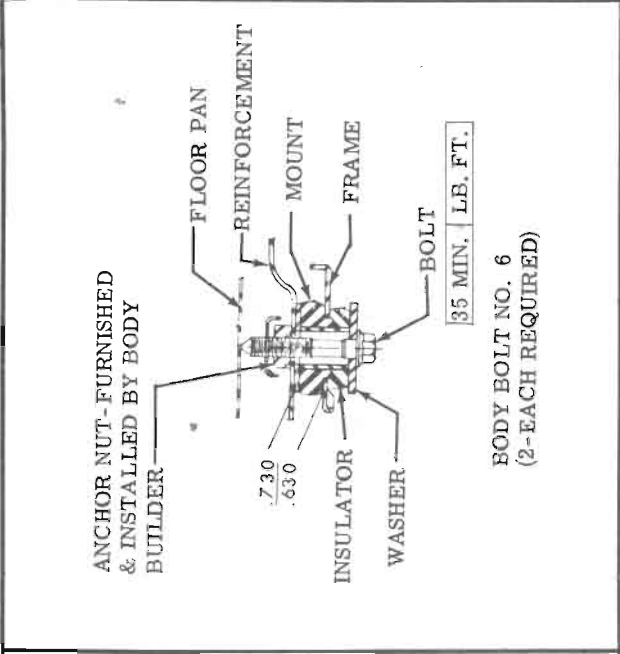

Figure 20-3 43-44000 (Less Sport Wagon) Body Mounts

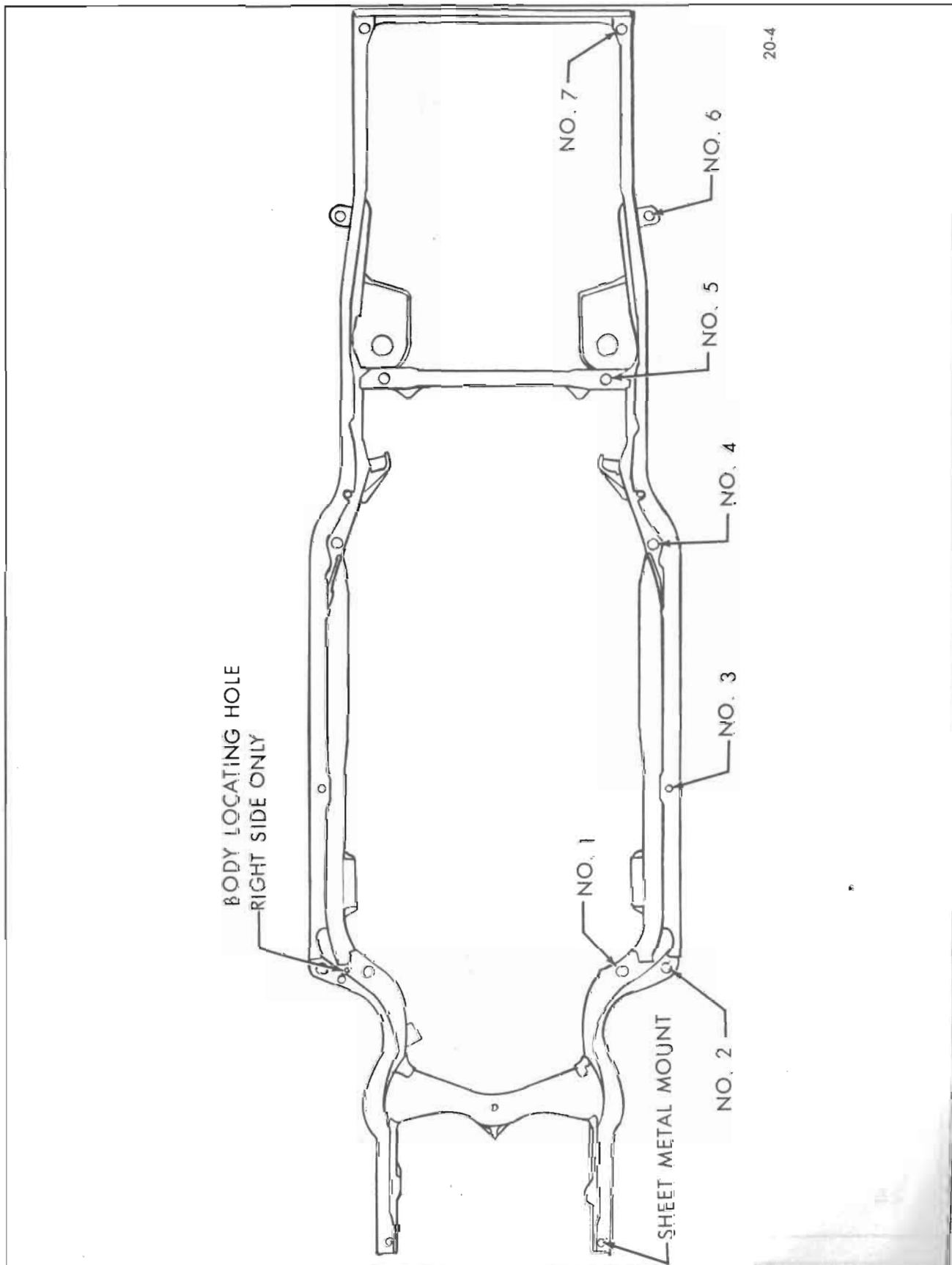

Figure 20-4 44000 (Sport Wagon Only) Frame

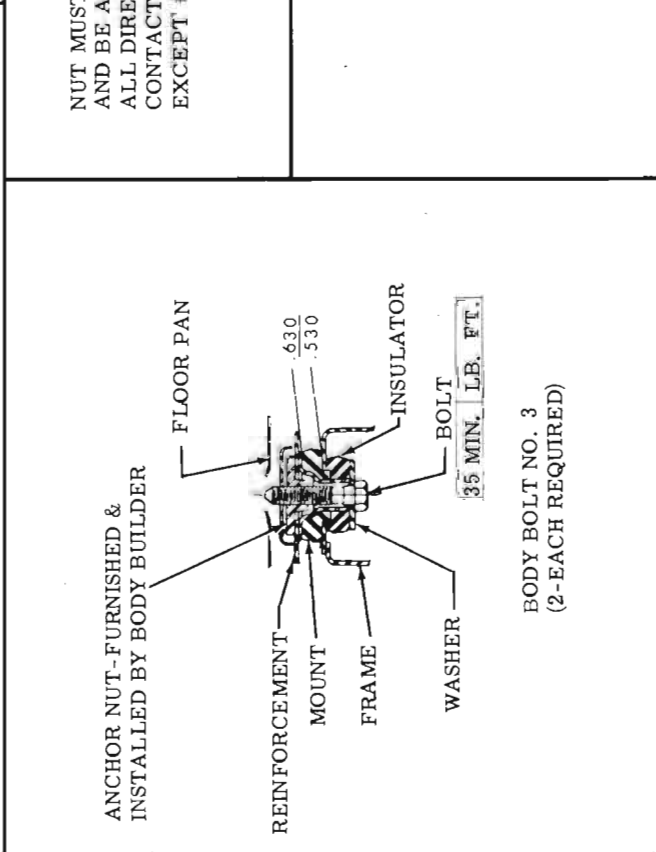
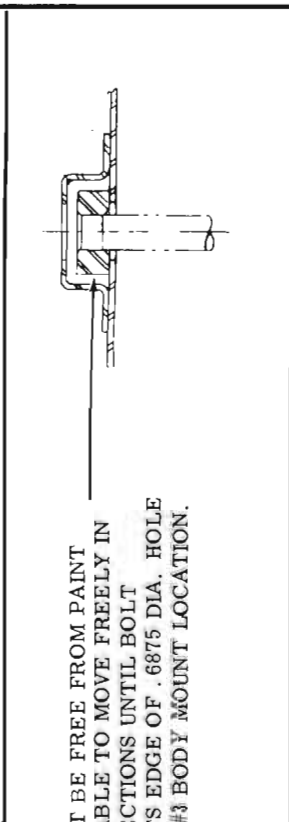
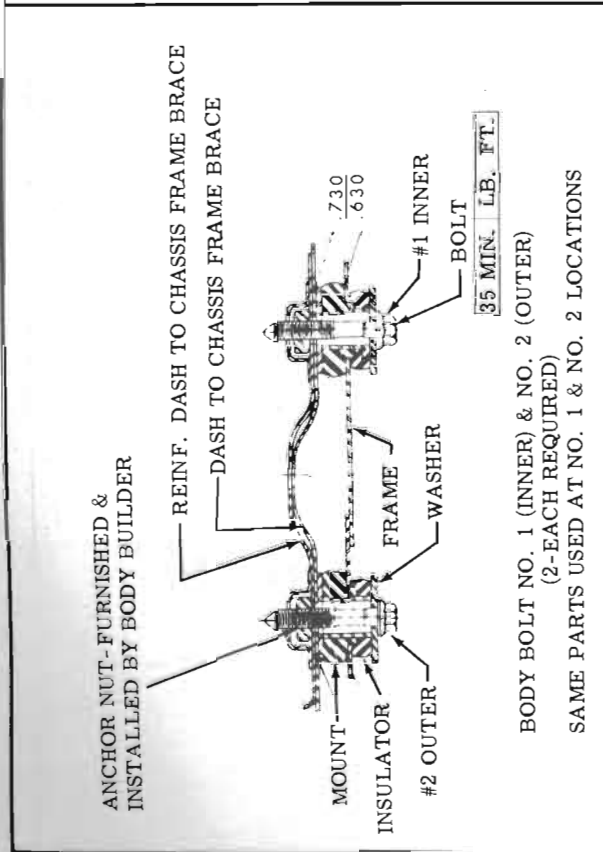
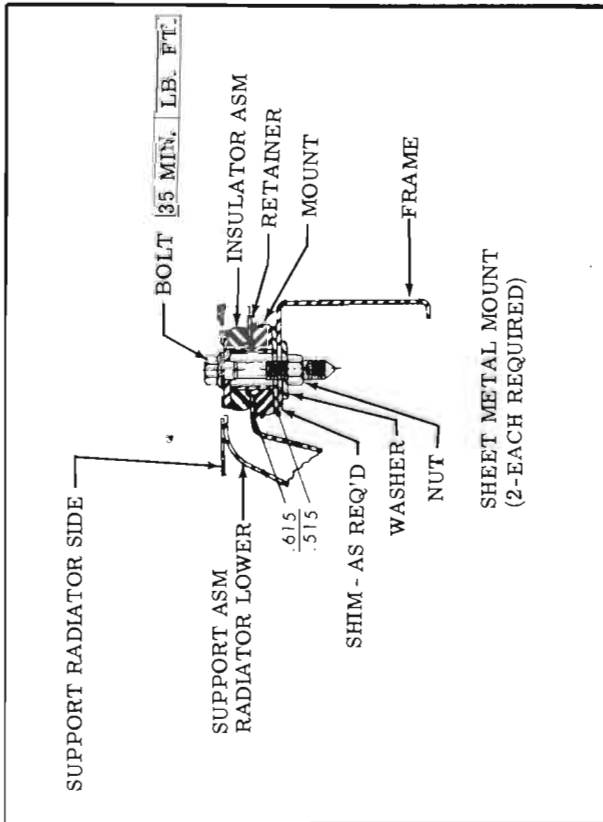
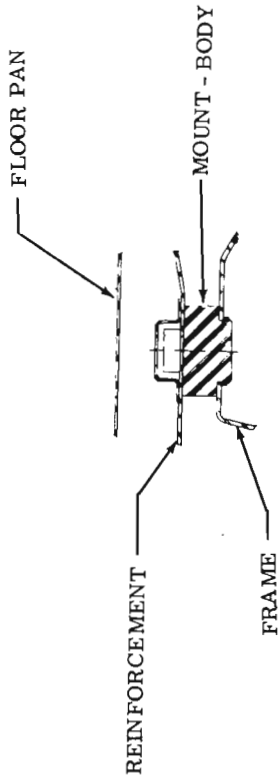
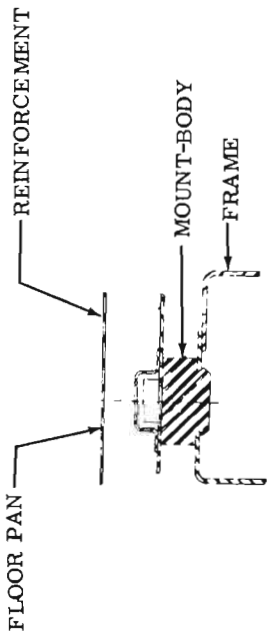

Figure 20-5 44000 (Sport Wagon Only) Body Mounts



BODY MOUNT NO. 5
(2-EACH REQUIRED)



BODY MOUNT NO. 4
(2-EACH REQUIRED)

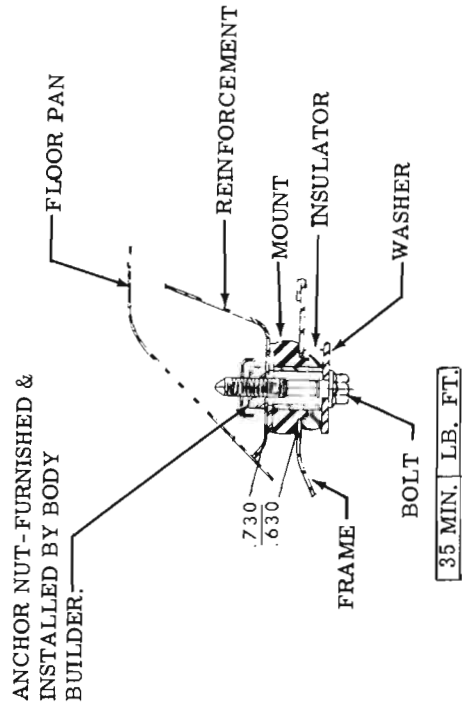

BODY BOLT NO. 7
(2-EACH REQUIRED)

20-6

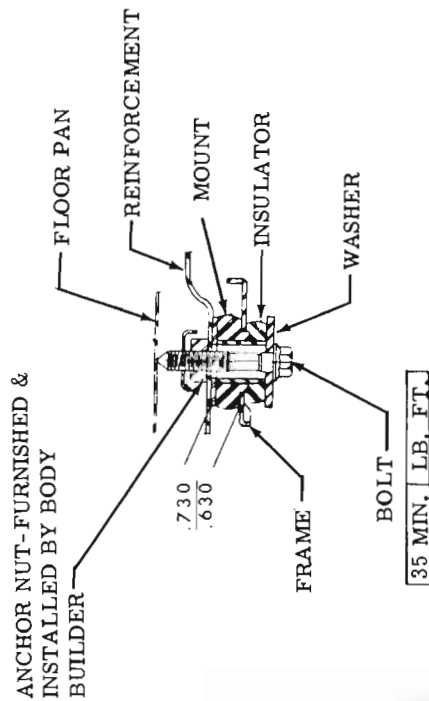

BODY BOLT NO. 6
(2-EACH REQUIRED)

Figure 20-6 44000 (Sport Wagon Only) Body Mounts