

150-4 VACUUM TRUNK RELEASE 43-44-45-46-48-49000 SERIES

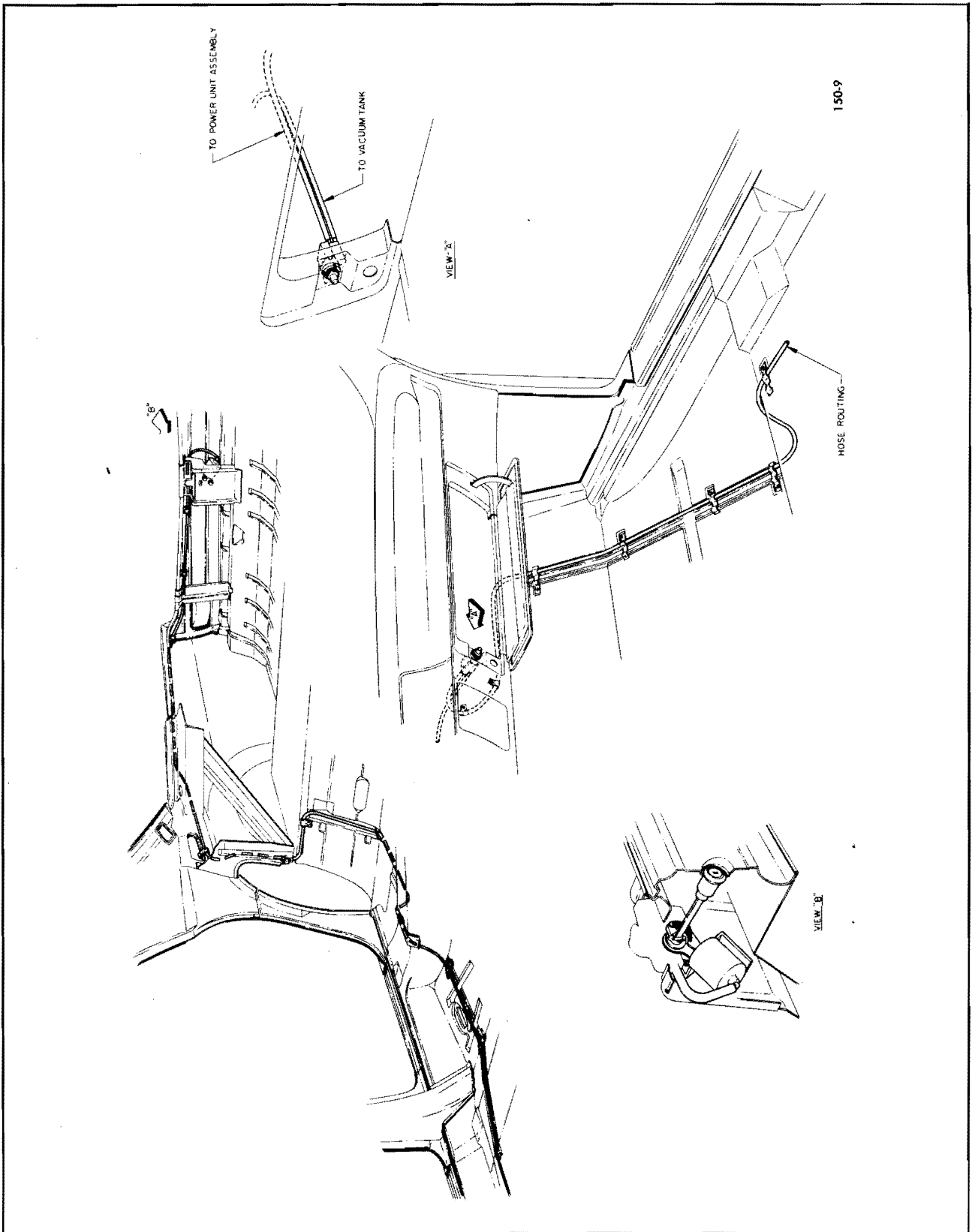

Figure 150-9--Vacuum Trunk Release 43-44000 Series

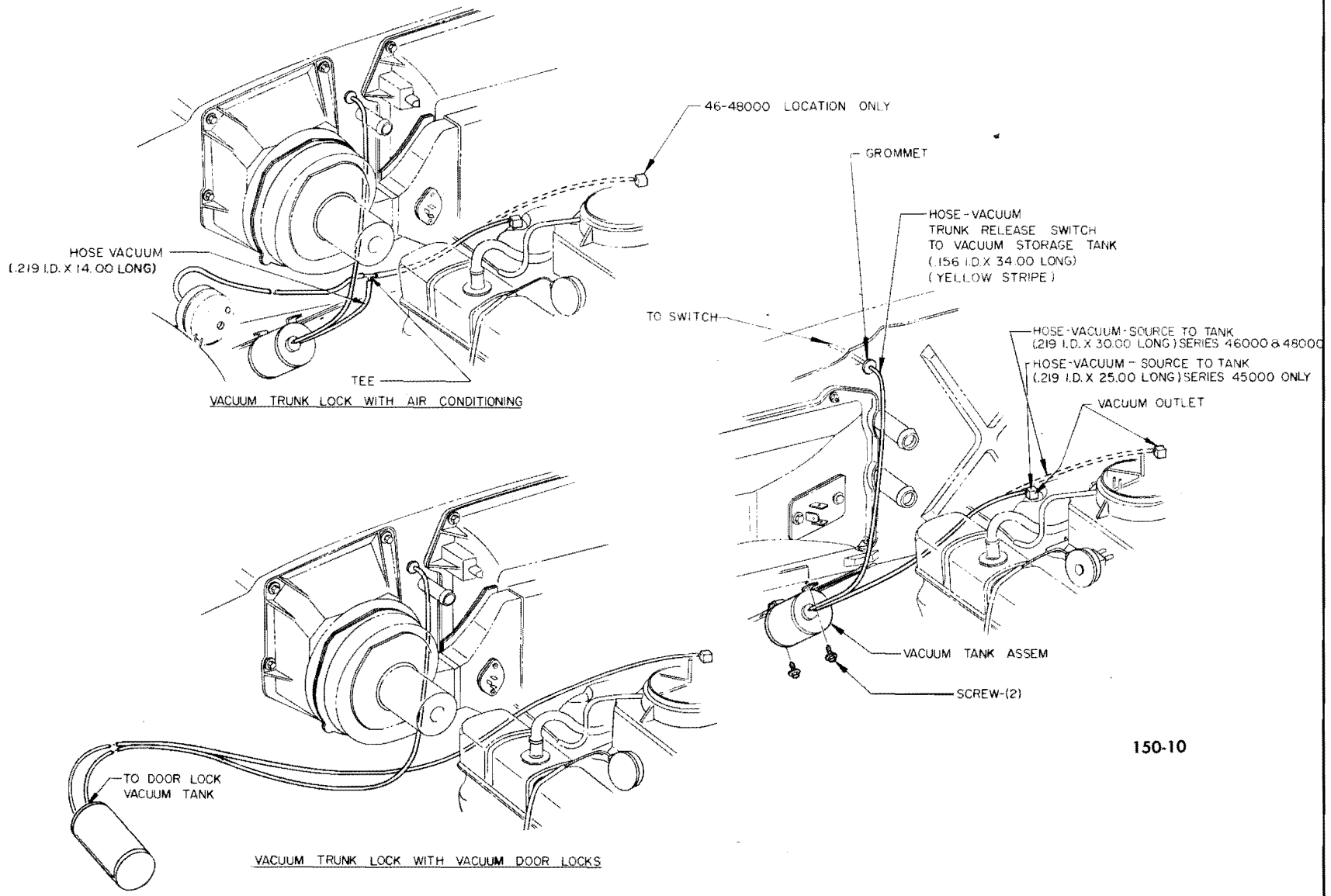

Figure 150-10—Vacuum Trunk Release Tank Installation 45-46-48000 Series

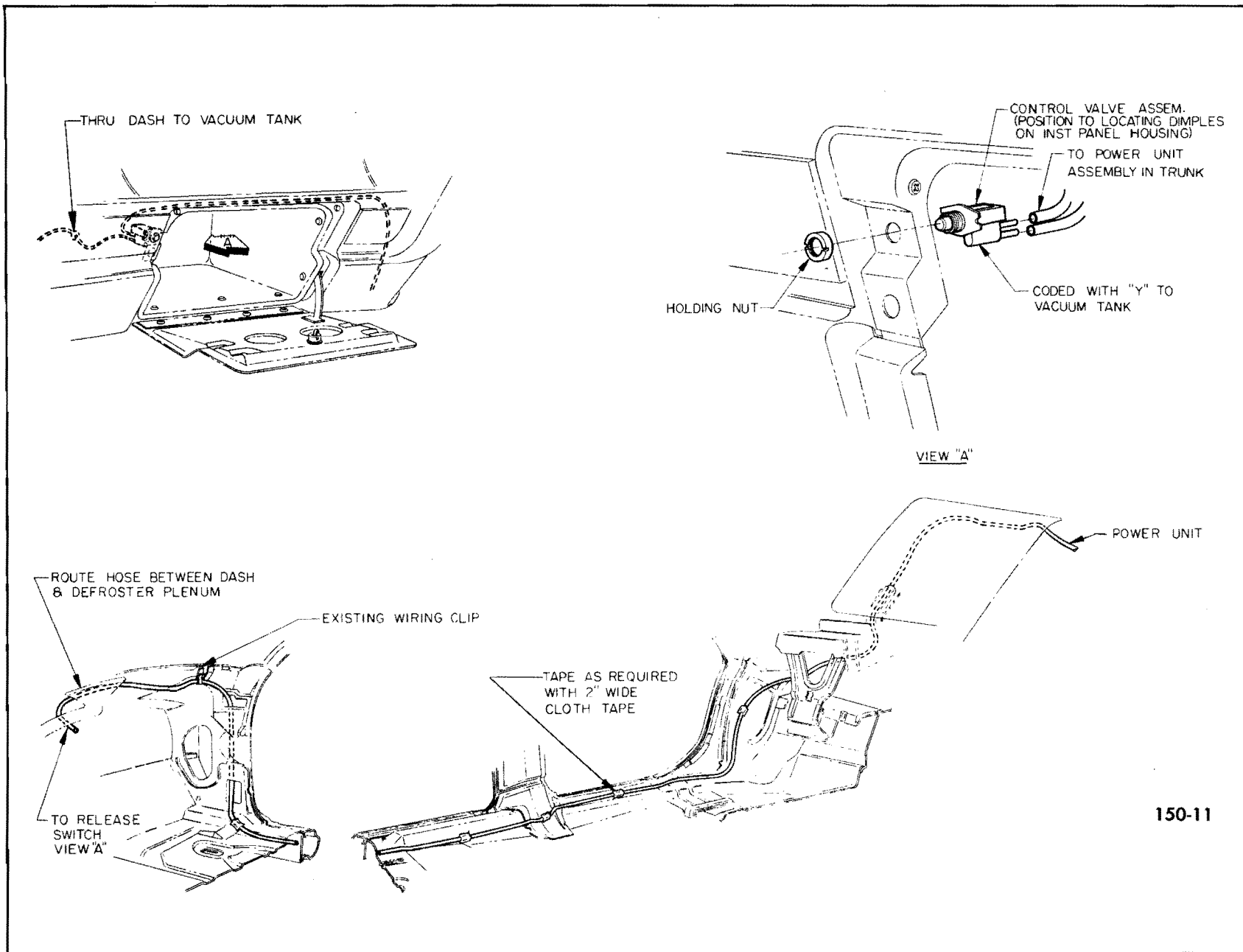
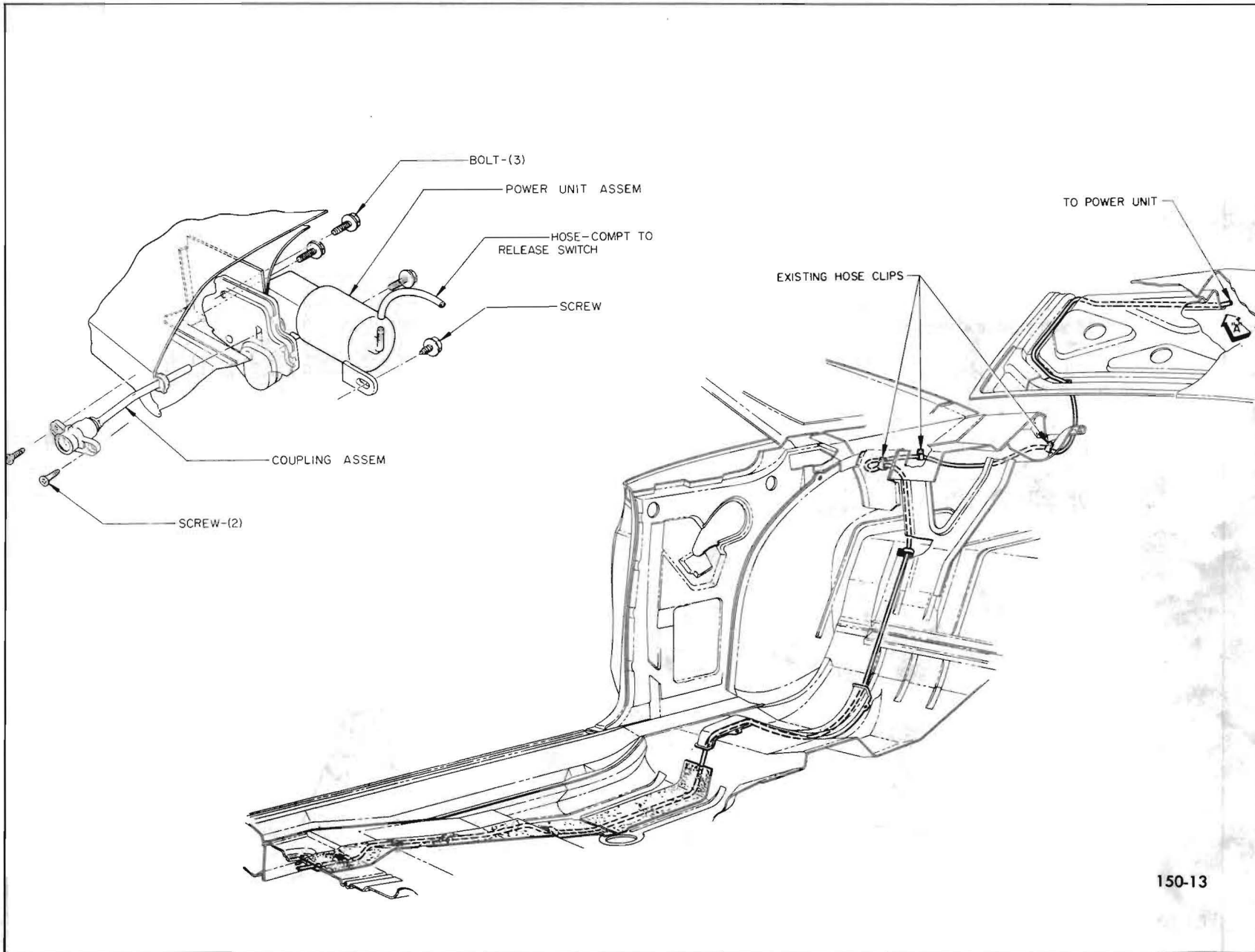

Figure 150-11—Vacuum Trunk Release Line Routing 45-46-48000 Series



150-13

Figure 150-13—Vacuum Trunk Release Line Routing 49000 Series