

SECTION 8

REAR QUARTER

INDEX

Subject	Page	Subject	Page
Introduction	8-2	Description	8-20
Rear Quarter Trim	8-2	Rear Quarter Inner Panel Sealing	8-20
Description	8-2	Rear Quarter Hardware Phantom Views	8-20
Rear Quarter Arm Rest	8-2	Rear Quarter Window - "A & B-11" and	
Rear Quarter Trim (Hang-On Type)	8-3	"A-07" Styles	8-21
Rear Quarter Trim (Insert Type)	8-4	Rear Quarter Window - "X-11" Styles	8-21
Rear Quarter Trim - Corvair Two Door		Rear Quarter Window Adjustments - "A & B"	
Styles Except Convertibles	8-4	Closed Styles	8-21
Rear Quarter Trim - Chevelle 13480 and		Rear Quarter Window Adjustments - "X"	
13680 Styles	8-5	Closed Styles	8-22
Folding Top Compartment Side Trim		Rear Quarter Window Regulator (Manual and	
Panel Assembly	8-6	Electric) - "A-B & X" Closed Styles	8-22
Rear Quarter Trim (Hang-On Type) -		Rear Quarter Window Rear Glass Run Channel -	
Convertible Styles	8-6	All Closed Styles	8-23
Rear Quarter Trim (Insert Type) - "A & Z"		Rear Quarter Window Front Glass Run Channel -	
Convertible Styles	8-7	All Closed Styles	8-24
Rear Quarter Arm Rest and Trim - "E"		Rear Quarter Window Guide Assembly -	
Body Styles	8-7	"X-11" Styles	8-24
Compartment Shelf Center Finishing Panel -		Rear Quarter Window Outer Strip Assembly -	
"E" Body Styles	8-8	All Closed Styles	8-24
Compartment Shelf Side Finishing Panels -		Rear Quarter Window Assembly - "17-37-47-	
"E" Body Styles	8-9	57-67 and 87" Styles	8-25
Rear Quarter Lower Trim - "B & C-39 and		A. Removal & Installation - "B & C-37 & 57"	
69" Styles	8-10	Styles	8-26
Rear Quarter Lower Trim - 33839, 33869 and		B. Removal & Installation - "B-47" Style	8-26
44439 Styles	8-10	C. Removal & Installation - "B & C-67"	
Rear Quarter Inner Trim Panel (Left Side) -		Styles	8-27
"B" Body Station Wagons	8-10	Adjustments - "B & C-37-47-57 and	
Spare Tire Cover Panel - "B" Body		67" Styles	8-28
Station Wagons	8-11	D. Removal & Installation - "A-17 and 67"	
Rear Quarter Wheelhouse Cover Panel (Right		Styles	8-28
Side) - "B" Station Wagons	8-11	Adjustments - "A-17 and 67" Styles	8-29
Rear Quarter Front Trim Panel (Right or		E. Removal & Installation - "E" Styles	8-30
Left Side) - "A" Station Wagons	8-14	Adjustments - "E" Styles	8-30
Spare Tire Cover Panel - "A" Station Wagons.	8-14	F. Removal & Installation - "X-37" Styles	8-30
Wheelhouse Trim Cover Panel (Right Side) -		Adjustments - "X-37" Styles	8-30
"A" Station Wagons	8-15	G. Removal & Installation - "Z-37" Styles	8-31
Rear Quarter Rear Trim Panel - All Station		Adjustments - "Z-37" Styles	8-35
Wagons Except 13435 and 23335	8-15	H. Removal & Installation - "Z-67" Styles	8-35
Wheelhouse Trim Cover Assembly (Left Side) -		Adjustments - "Z-67" Styles	8-35
All Station Wagons Except 23335 Styles	8-16	Rear Quarter Window Regulator Assembly	
Rear Quarter Rear Trim Panel - 13435 and		(Manual) - "B & C-37-47-57 and 67" Styles	8-35
23335 Styles	8-16	Rear Quarter Window Regulator Assembly	
Rear Quarter Rear Trim Panel - Chevy II		(Electric) - "B & C-37-47-57 and 67" Styles	8-35
Station Wagons	8-16	Rear Quarter Window Regulator Assembly	
Rear Quarter Front Trim Panel - Chevy II		(Manual & Electric) - "A-E-X & Z"	
Station Wagons	8-16	Hardtop & Convertibles	8-36
Rear Quarter Wheelhouse Trim Cover - Chevy II		Rear Quarter Window Front Guide - "B & C-37-	
Station Wagons	8-17	47-57 and 67" Styles	8-38
Rear Quarter Stationary Window - "A & B"		Rear Quarter Window Rear Guide - "B & C-37-	
Station Wagons	8-18	47-57 and 67" Styles	8-38
Description	8-18	Rear Quarter Window Front Guide - "A-E-X &	
Removal	8-18	Z" Hardtop & Convertible Styles	8-40
Installation	8-18	Rear Quarter Window Glass Run Channel -	
Rear Quarter Stationary Window - "X"		Chevrolet "B-47" Styles	8-41
Station Wagon	8-20	Rear Quarter Window Upper Glass Run	
Removal	8-20	Channel - "E" Styles	8-42
Installation	8-20	Rear Quarter Window Outer Strip Assembly -	
Rear Quarter Hardware	8-20	"B-37 and 67" Styles Except Chevrolet	8-43

INTRODUCTION

Section Eight, pertaining to Rear Quarters, covers all service procedures applicable to this area of the body, for all styles. The contents are divided into three separate categories; specifically, Trim, Sta-

tionary Glass and Hardware (See Index). The material within each basic category is arranged, as closely as possible, in the sequence in which individual assemblies would be removed.

REAR QUARTER TRIM

DESCRIPTION

Rear quarter trim assemblies for all two-door styles consist of the following two types:

1. Hang on type, where upper edge of trim panel is secure on upper edge of rear quarter inner panel.
2. Insert type where trim panel is secured by retainers and sealing plugs.

REAR QUARTER ARM REST "17-27-37 AND 57" STYLES

Removal and Installation

1. Remove rear seat cushion and rear seat back assemblies as described under "Rear Seats".

2. Remove seat back filler panel to rear quarter inner panel attaching screws (Figs. 8-1 and 8-2) and remove filler panel.
3. Remove arm rest attaching screws at front, rear and bottom arm rest (Figs. 8-1 and 8-2).
4. On styles with electrical devices in arm rest assembly, carefully detach arm rest from rear quarter inner panel sufficiently to disconnect wire harness connectors. Figures 8-3 and 8-4 are indicative of electrical installations in rear quarter arm rests. Lift arm rest in an upward, inboard movement and remove assembly from rear quarter inner panel.
5. To install, reverse removal procedure.

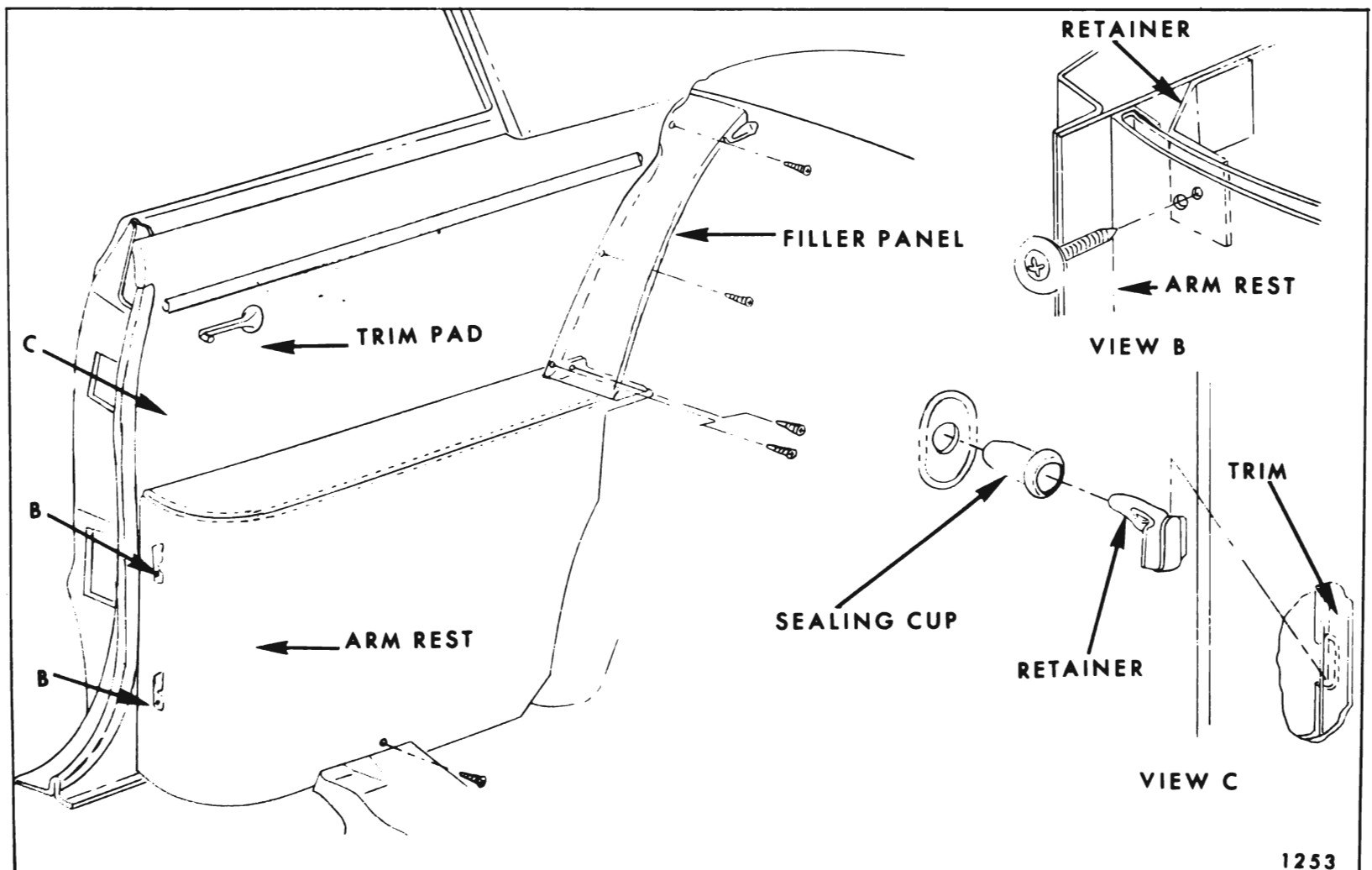

Fig. 8-1—Rear Quarter Trim Assembly (Insert Type)

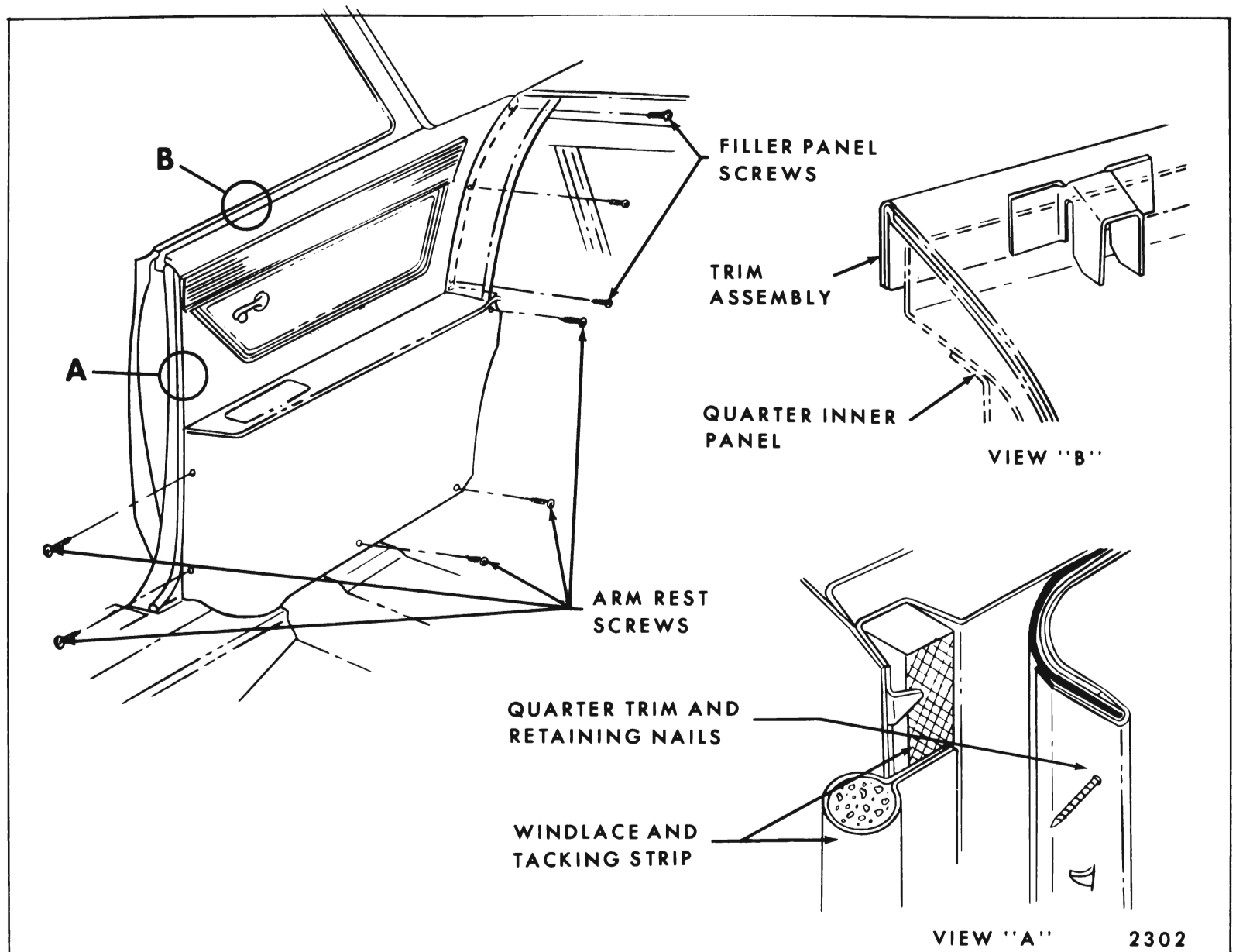

Fig. 8-2—Rear Quarter Trim Assembly (Hang-On Type)

REAR QUARTER TRIM (HANG-ON TYPE)—“A-B & C” TWO DOOR STYLES EXCEPT CONVERTIBLES

Removal and Installation

1. Where present, remove applied type rear quarter arm rest and window regulator inside handle as described in the “Door Trim” section of the Body Service Manual.
2. Remove rear seat cushion and seat back assemblies as described in the “Seat” section of the Body Service Manual.
3. On styles with floor mounted arm rest, remove rear quarter arm rest assembly as previously described.
4. a. On “A” body styles with hang-on type trim assemblies proceed as follows:

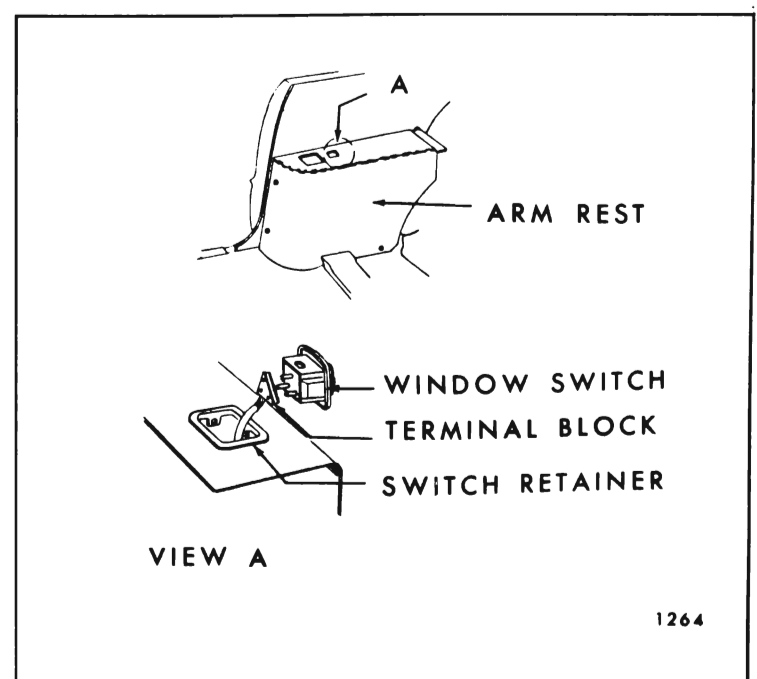

Fig. 8-3—Rear Quarter Arm Rest Window Switch

Remove front door sill plate and disengage rear body lock pillar finishing strip. With a screwdriver, or other suitable flat bladed tool, disengage trim assembly retaining clips from sealing plugs along leading edge of rear body lock pillar (Fig. 8-1).

Lift trim assembly upward to disengage top of trim from top of rear quarter inner panel.

NOTE: On styles equipped with electric window regulators, disconnect wire harness connector from switch on trim assembly.

- b. On "B & C" body styles use trim panel removing tool (J-6335) or equivalent to carefully pry trim assembly retaining nails from tacking strip; then lift trim assembly upward to disengage from retainers at top of rear quarter inner panel and remove assembly from body.

5. To install rear quarter trim assembly, reverse removal procedure.

NOTE: Trim pad nailing strip replacement tabs, or trim pad retaining clips and corresponding sealing plugs are available as service parts.

REAR QUARTER TRIM (INSERT TYPE)— "A & X" BODY TWO-DOOR STYLES EXCEPT CONVERTIBLES

Removal and Installation

1. Where present, remove applied type rear quarter arm rest and window regulator inside handle as described in the "Door Trim" section of the Body Service Manual.
2. Remove rear seat cushion and seat back assemblies, as described in the "Seat" section of the Body Service Manual.
3. On styles with floor mounted arm rest, remove rear quarter arm rest assembly, as previously described.
4. Remove door sill plate and disengage pinch-weld finishing strip along lower section of rear body lock pillar.
5. Carefully detach approximately three inches of the upper front cemented edge of trim material from body lock pillar pinchweld flange (Fig. 8-5 View "B"). Carefully bend or bow trim inboard sufficiently to disengage upper edge of trim from under finishing molding retainer (Fig. 8-5, View "C").

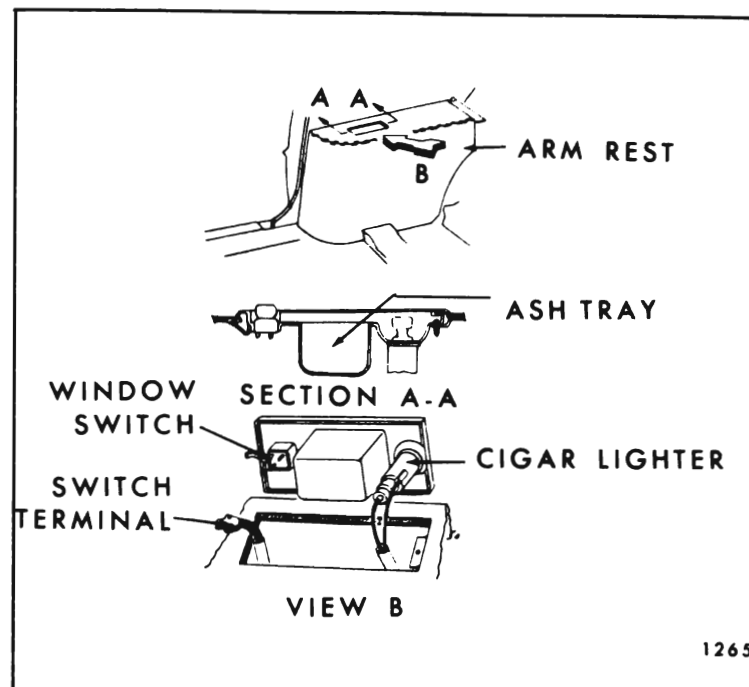

Fig. 8-4—Rear Quarter Arm Rest Ash Tray and Cigar Lighter

On "X" styles carefully bend or bow lower portion of trim sufficiently to disengage lower edge of trim from under lower finishing molding retainer.

6. Carefully pivot trim assembly forward; then, break cement bond along pinchweld flange of rear body lock pillar and remove assembly from body.

NOTE: If trim assembly incorporates electric window switch, disconnect wire harness connector from window switch.

The finishing molding retainer (Fig. 8-5, View "C") is retained by screws and can be removed at this point, where required.

7. To install, reverse removal procedure. Prior to installation of pinchweld finishing strip, recement forward edge of trim to pinchweld flange (Fig. 8-5, View "B").

REAR QUARTER TRIM—CORVAIR TWO-DOOR STYLES EXCEPT CONVERTIBLES

Removal and Installation

1. Remove rear seat cushion and rear seat back, as described in the "Seat" section of the Body Service
2. Remove ash tray and two screws securing ash tray housing to rear quarter inner panel (Fig. 8-6, View in Circle "A").

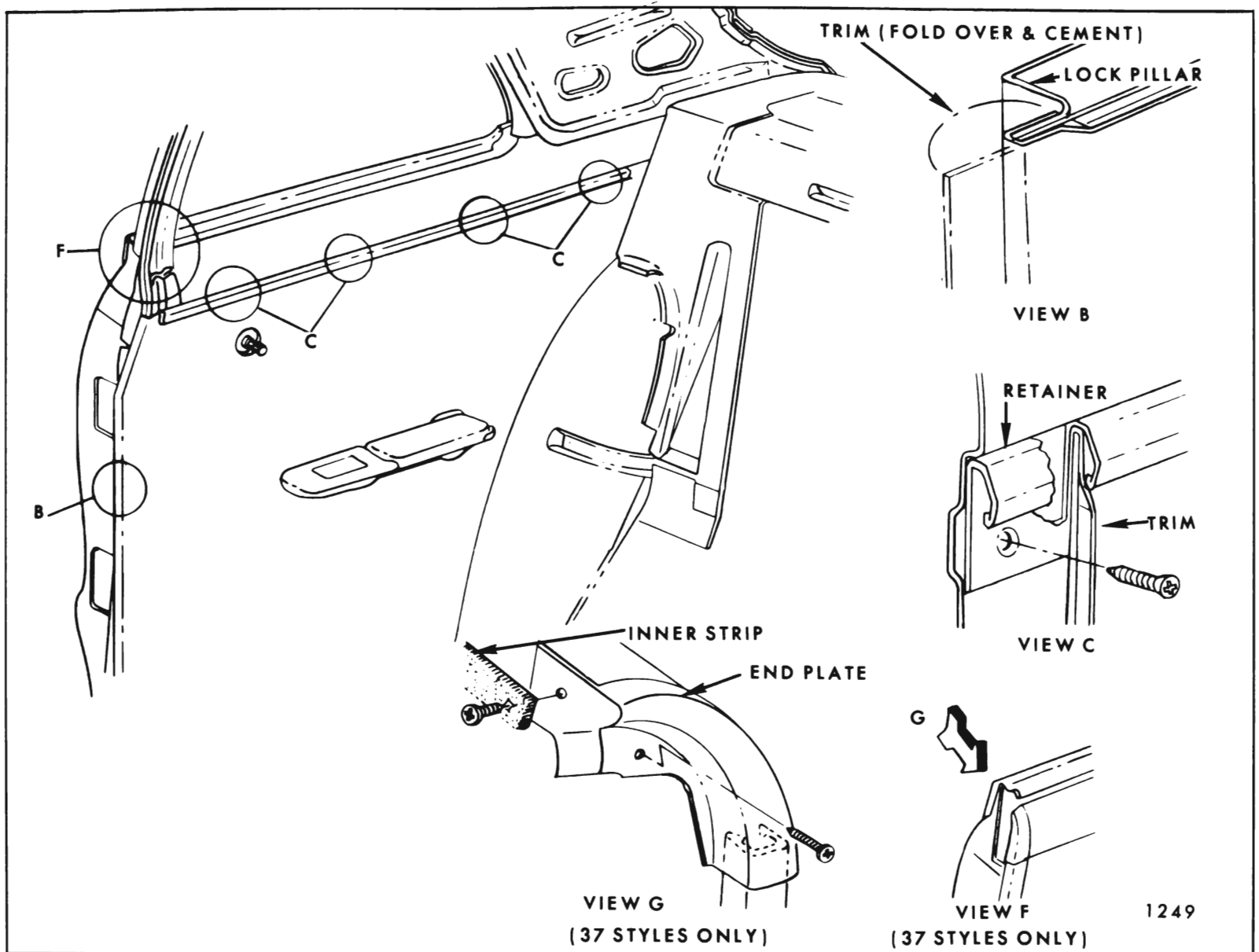

Fig. 8-5—Rear Quarter Trim Assembly—"A & X" Two Door Styles Except Convertibles

3. Remove front door sill plate and disengage pinchweld finishing strip along rear body lock pillar.
4. With a flat bladed tool, disengage trim pad retaining clips from plastic sealing plugs in rear quarter inner panel (Fig. 8-6, Section "A-A").
5. With a flat bladed tool, break cement bond at lower section of trim assembly to rear quarter inner panel (Fig. 8-6, Section "C-C").
6. Carefully pivot trim assembly forward to break cement bond at pinchweld flange of rear body lock pillar and remove assembly from body (Fig. 8-6, Section "B-B").
7. To install, reverse removal procedure. Prior to installation of pinchweld finishing strip,

cement forward overlapping edge of trim assembly to pinchweld flange outboard surface. Also, re-cement bottom edge of trim assembly to rear quarter inner panel.

REAR QUARTER TRIM—CHEVELLE 13480 AND 13680 STYLES

Removal and Installation

1. Remove seat cushion and seat back assemblies.
2. Detach rear body lock pillar pinchweld finishing strip (see section "B-B" in Fig. 8-7) and remove front door sill plate.
3. Remove screws securing rear quarter trim to body panel and remove assembly from body (see Fig. 8-7).
4. To install, reverse removal procedure.

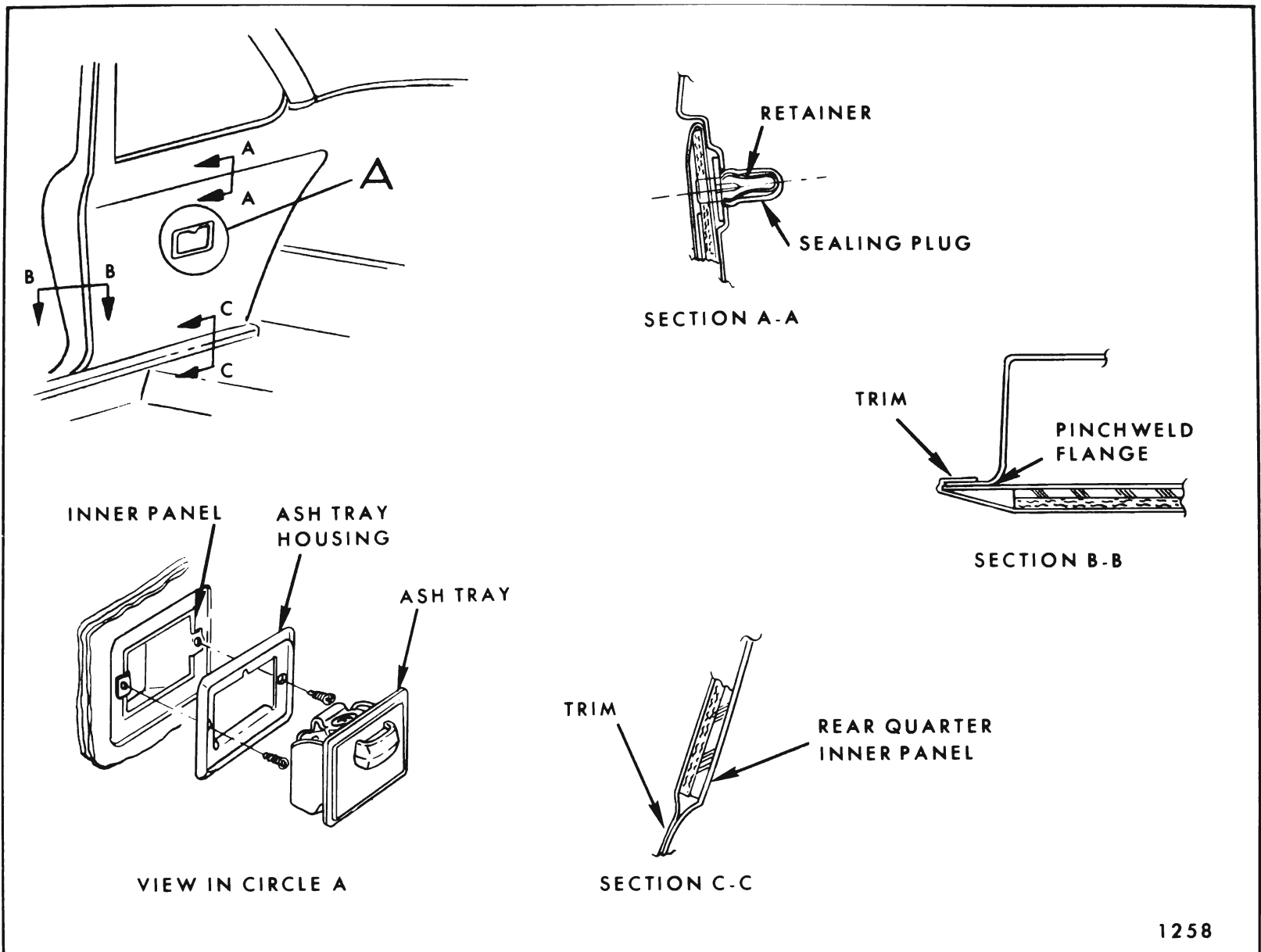

Fig. 8-6—Rear Quarter Trim Assembly - "Z" Body Styles

FOLDING TOP COMPARTMENT SIDE TRIM PANEL—CONVERTIBLE STYLES

Removal and Installation

1. Remove rear seat cushion and seat back assemblies.
2. Remove exposed attaching screws securing front and rear of side trim panel.
3. Raise trim panel and move it inboard.
4. Disconnect electrical leads, where present, and remove side trim panel.

NOTE: On styles equipped with rear quarter lamp assemblies, disconnect lamp as shown in Figure 8-8.

5. To install, reverse removal procedure.

NOTE: As a bench operation, the arm rest assembly can be removed from the folding top compartment side trim assembly by removing screws installed on the reverse side.

REAR QUARTER TRIM (HANG-ON TYPE)—“A-B & C” CONVERTIBLE STYLES

Removal and Installation

1. Remove folding top compartment side trim panel assembly, as previously described.
2. On styles with manually operated windows, remove window regulator handle and anti-friction washer.
3. a. On “A” body styles with hang-on type trim assembly remove door sill plate and disengage lock pillar pinchweld finishing strip.

Also remove lock pillar finishing cap. With a screwdriver or other suitable flat bladed tool, disengage trim assembly retaining clips from sealing plugs along leading edge of rear body lock pillar (Fig. 8-1, View "C"). Lift trim assembly upward to disengage top of trim from top of rear quarter inner panel.

- b. On "B & C" body styles use trim panel removing tool (J-6335) or equivalent to carefully pry trim assembly retaining nails from tacking strip; then, lift trim assembly upward to disengage from retainers at top of rear quarter inner panel and remove assembly from body.

4. To install rear quarter trim assembly, reverse removal procedure.

NOTE: Trim pad nailing strip replacement tabs, or trim pad retaining clips and corresponding sealing plugs are available as service parts.

REAR QUARTER TRIM (INSERT TYPE)— "A & Z" BODY CONVERTIBLES

Removal and Installation

1. Remove folding top compartment side trim panel assembly, as previously described.
2. On styles with manually operated windows, remove window regulator handle and anti-friction washer.
3. Remove door sill plate and disengage lock pillar pinchweld finishing strip.
4. Carefully detach approximately three inches of the upper front cemented edge of trim material from body lock pillar pinchweld flange (Fig. 8-9, View "B"). Carefully bend or bow trim inboard sufficiently to disengage upper edge of trim from under finishing molding retainer (Fig. 8-9, View "C").
5. Carefully pivot trim assembly forward; then, break cement bond along pinchweld flange of rear body lock pillar and remove assembly from the body.

NOTE: If trim assembly incorporates electric window switch, disconnect wire harness connector from window switch.

The finishing molding retainer (Fig. 8-9, View "C") is retained by screws and can be removed at this point, where required.

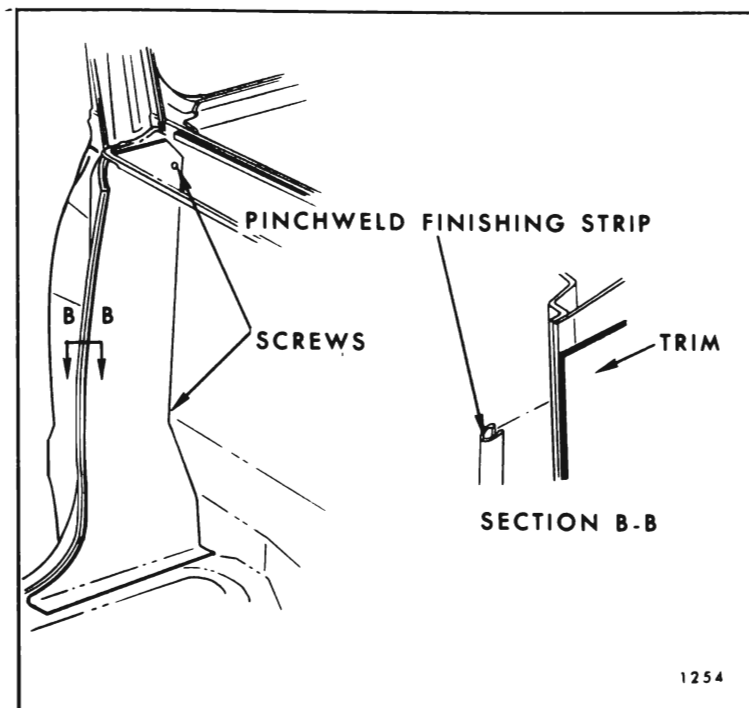

Fig. 8-7—Rear Quarter Trim Assembly - "A-80" Styles

6. To install rear quarter trim assembly, reverse removal procedure. Prior to installation of pinchweld finishing strip, recement forward edge of trim to pinchweld flange (see Fig. 8-9, View "B").

REAR QUARTER ARM REST AND TRIM— "E" BODY STYLES

Removal and Installation

1. Remove rear seat cushion and rear seat back assemblies, as described under "Rear Seats".
2. On Oldsmobile 39487 remove seat back filler panel attaching screws (Fig. 8-10) and remove filler panel.
3. Remove arm rest attaching screws (Figs. 8-10 and 8-11). On styles with electrical equipment in arm rest, carefully detach arm rest from quarter panel sufficiently to disconnect wire harness connectors; then, remove arm rest from rear quarter panel.
4. Remove rear quarter trim assembly attaching screws (Fig. 8-11 and 8-10). Use trim panel removing tool (J-6335) or equivalent to carefully pry trim assembly retaining nails (Fig. 8-11) from tacking strip along body lock pillar; then lift trim assembly upward to disengage from retainers at top of rear quarter inner panel and remove assembly from body.

NOTE: If trim assembly incorporates an electric window switch, disconnect wire harness connector from switch on trim assembly.

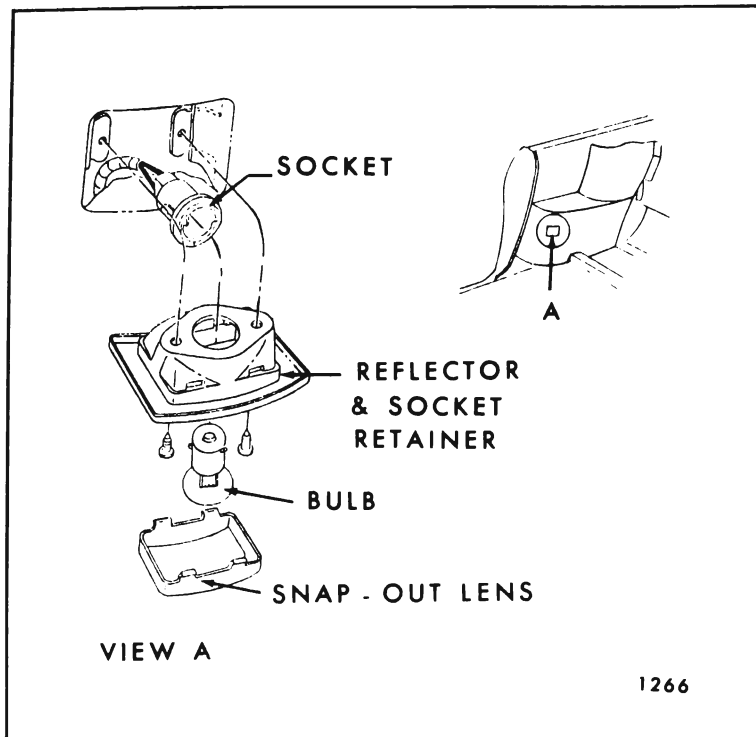

Fig. 8-8—Rear Quarter Arm Rest Courtesy Lamp

5. To install rear quarter trim assembly or rear quarter arm rest, reverse removal procedure.

NOTE: Trim assembly nailing strip replacement tabs are available as a service part.

COMPARTMENT SHELF CENTER FINISHING PANEL—"E" BODY STYLES

Removal and Installation

1. Remove rear seat cushion and seat back assemblies as described under "Rear Seats".
2. From inside rear compartment remove compartment shelf center finishing panel attaching screws or nuts at locations shown in Fig. 8-12 for Buick or Fig. 8-13 for Oldsmobile.
3. From inside body pull center finishing panel forward sufficiently to disengage both front and rear edge of center finishing panel from retainers (see Figs. 8-12 and 8-13, Views "B & F"); then, lift panel upward and remove from shelf panel.

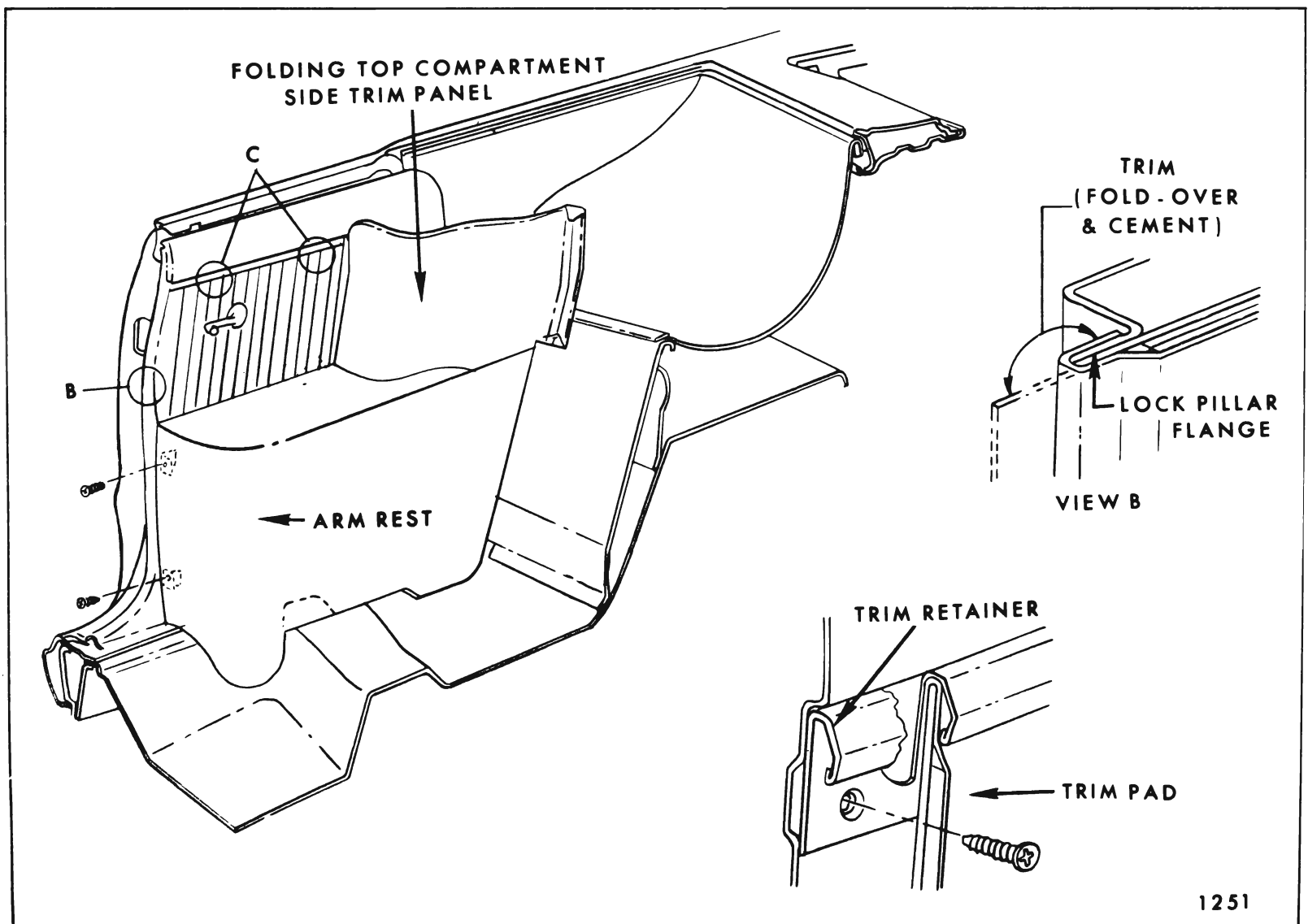

Fig. 8-9—Rear Quarter Trim Assembly - Convertible Styles

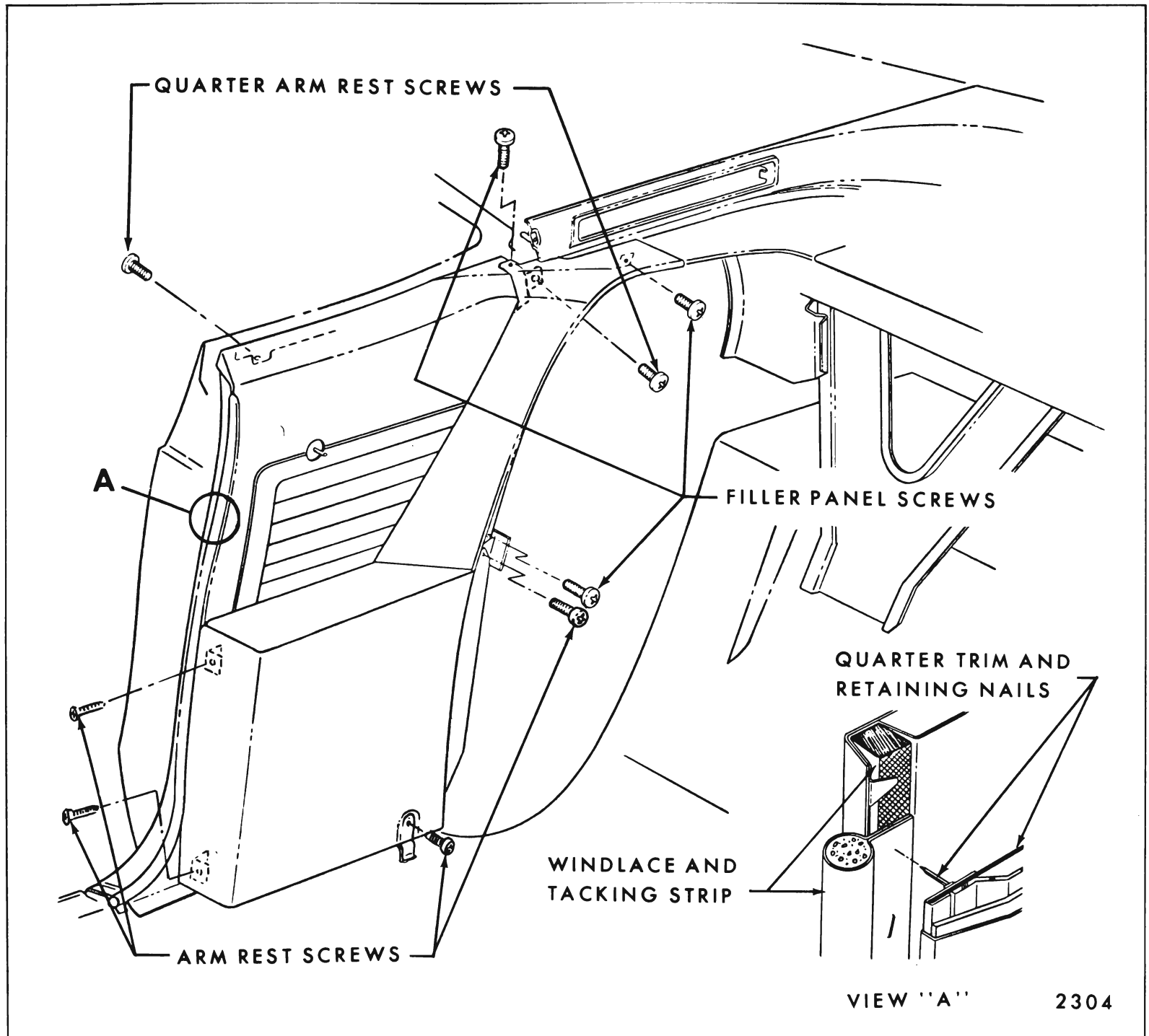

Fig. 8-10—Rear Quarter Trim Assembly - "E" Body 39487 Style

4. To install compartment shelf center finishing panel, reverse removal procedure.

COMPARTMENT SHELF SIDE FINISHING PANELS—"E" BODY STYLES

Removal and Installation

1. Remove rear seat cushion and rear seat back assemblies, as described under "Rear Seats".
2. Remove compartment shelf center finishing panel, as previously described.
3. a. On Oldsmobile 39487 Style remove seat back filler panel attaching screws (Fig. 8-11) and remove filler panel.
b. On Oldsmobile 39687 and Buick 49487 Styles remove rear quarter trim assembly, as previously described.
4. Remove compartment shelf side finishing panel attaching screws (Figs. 8-12 and 8-13) and remove side finishing panel. On Oldsmobile styles disconnect courtesy lamp feed wires.
5. To install compartment shelf side finishing panel, reverse removal procedure.

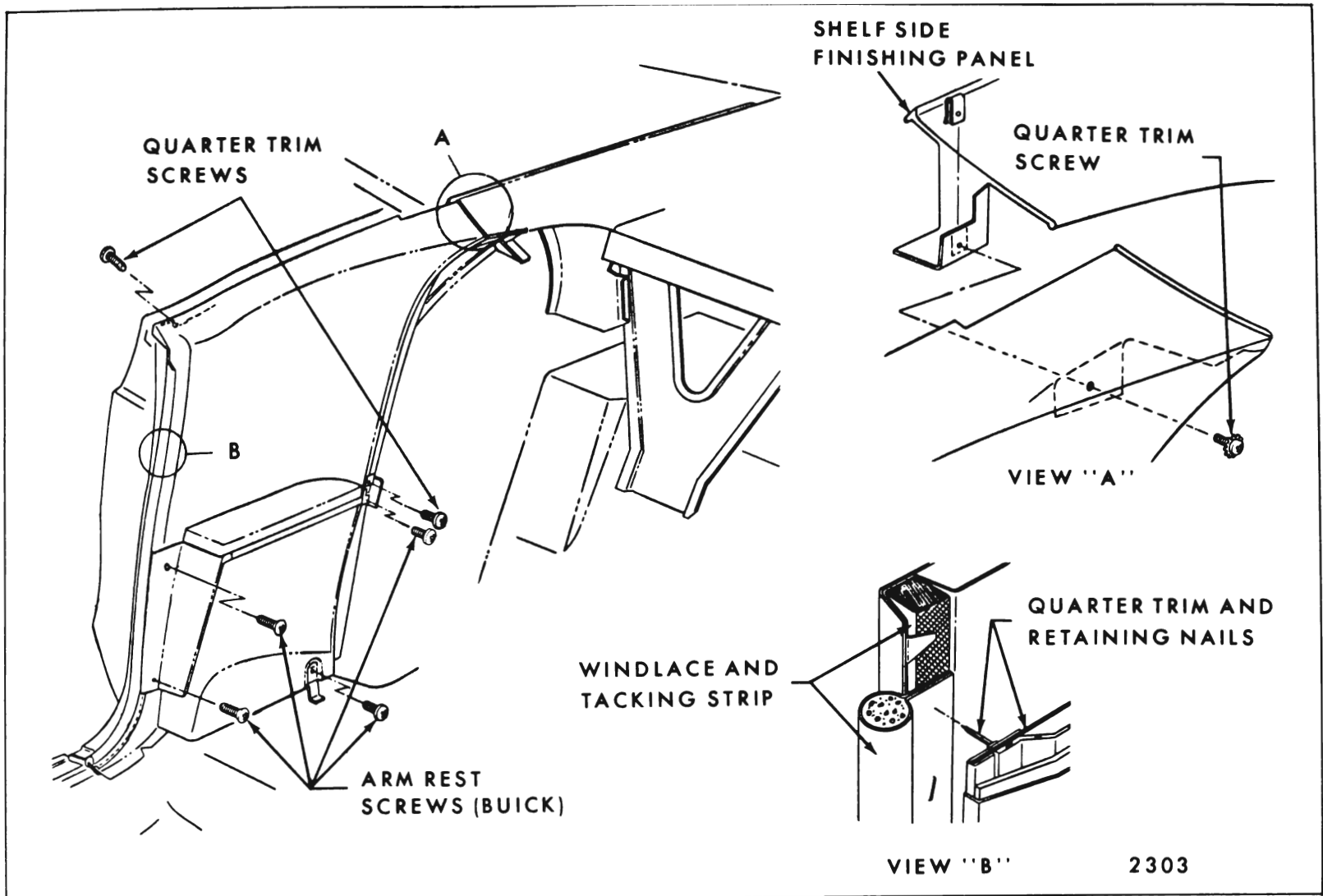

Fig. 8-11—Rear Quarter Arm Rest and Trim Assembly - "E" Body

REAR QUARTER LOWER TRIM— "B & C" BODY "39 AND 69" STYLES

Removal and Installation

1. Remove rear seat cushion and rear seat back assemblies.
2. Remove back window and rear quarter or roof rail garnish moldings as required.
3. With tool J-6335, or any other suitable flat bladed tool, pry trim assembly retaining nails from tacking strip (see Fig. 8-14).
4. Lift trim assembly upward to disengage from retainer at top of rear quarter inner panel and remove trim assembly.
5. To install, reverse removal procedure.

REAR QUARTER LOWER TRIM— OLDSMOBILE 33839, 33869, AND BUICK 44439 STYLES

Removal and Installation

1. Remove rear seat cushion and rear seat back assemblies.

2. Detach rear body lock pillar finishing strip and remove rear door sill plate (see section "B-B" in Fig. 8-15).
3. With a putty knife, or other suitable flat bladed tool, detach trim assembly at cemented areas indicated in Fig. 8-15.
4. To install, reverse removal procedure.

REAR QUARTER INNER TRIM PANEL (LEFT SIDE)—"B" BODY STATION WAGON STYLES

Removal and Installation

1. Remove rear quarter stationary window front and lower garnish moldings.
2. Remove all screws securing trim panel to rear quarter inner panel (Fig. 8-16).
3. With a suitable flat-bladed tool, carefully disengage trim retainers from rear quarter inner panel along leading edge of rear body lock

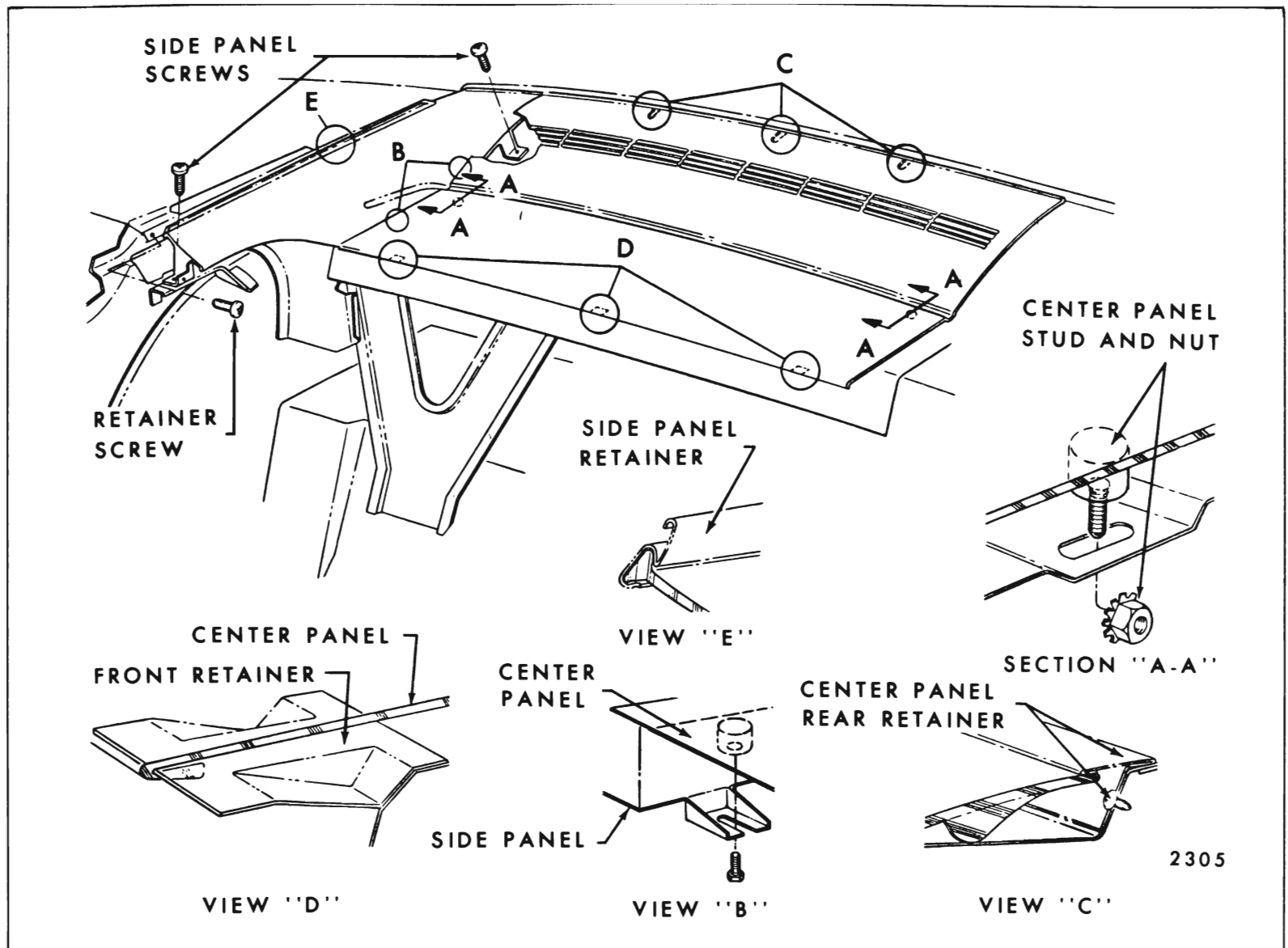

Fig. 8-12—Compartment Shelf Trim - Buick "E" Body

pillar (on front edge of rear quarter front trim assembly) (Fig. 8-16).

- Lift assembly upward slightly to disengage from rear quarter inner panel and remove assembly from body. On styles equipped with courtesy lamp disconnect feed wire from switch and lamp (Fig. 8-16, View "A").

NOTE: The rear quarter front trim assembly can be removed at this point, as a bench operation, by breaking cement bond between trim and metal panel of rear quarter inner trim panel assembly. The rear quarter front trim is a sub-assembly of the rear quarter inner trim panel; left and right sides.

- To install, reverse removal procedure.

SPARE TIRE COVER PANEL— "B" BODY STATION WAGON STYLES

The spare tire cover panel is secured to a retainer

at the belt line by a folding catch type handle. To remove the panel, disengage the catch and lift the panel upward. To install, reverse removal procedure.

The handle can be adjusted "in" or "out" to increase or decrease closing effort. To adjust, loosen the handle attaching screws; position the handle as desired and tighten the screws.

REAR QUARTER WHEELHOUSE COVER PANEL (RIGHT SIDE)— "B" BODY STATION WAGON STYLES

Removal and Installation

- Remove spare tire cover.
- Remove rear quarter stationary window front and lower garnish moldings.
- Remove all screws securing trim panel to rear quarter inner panel (Fig. 8-17).

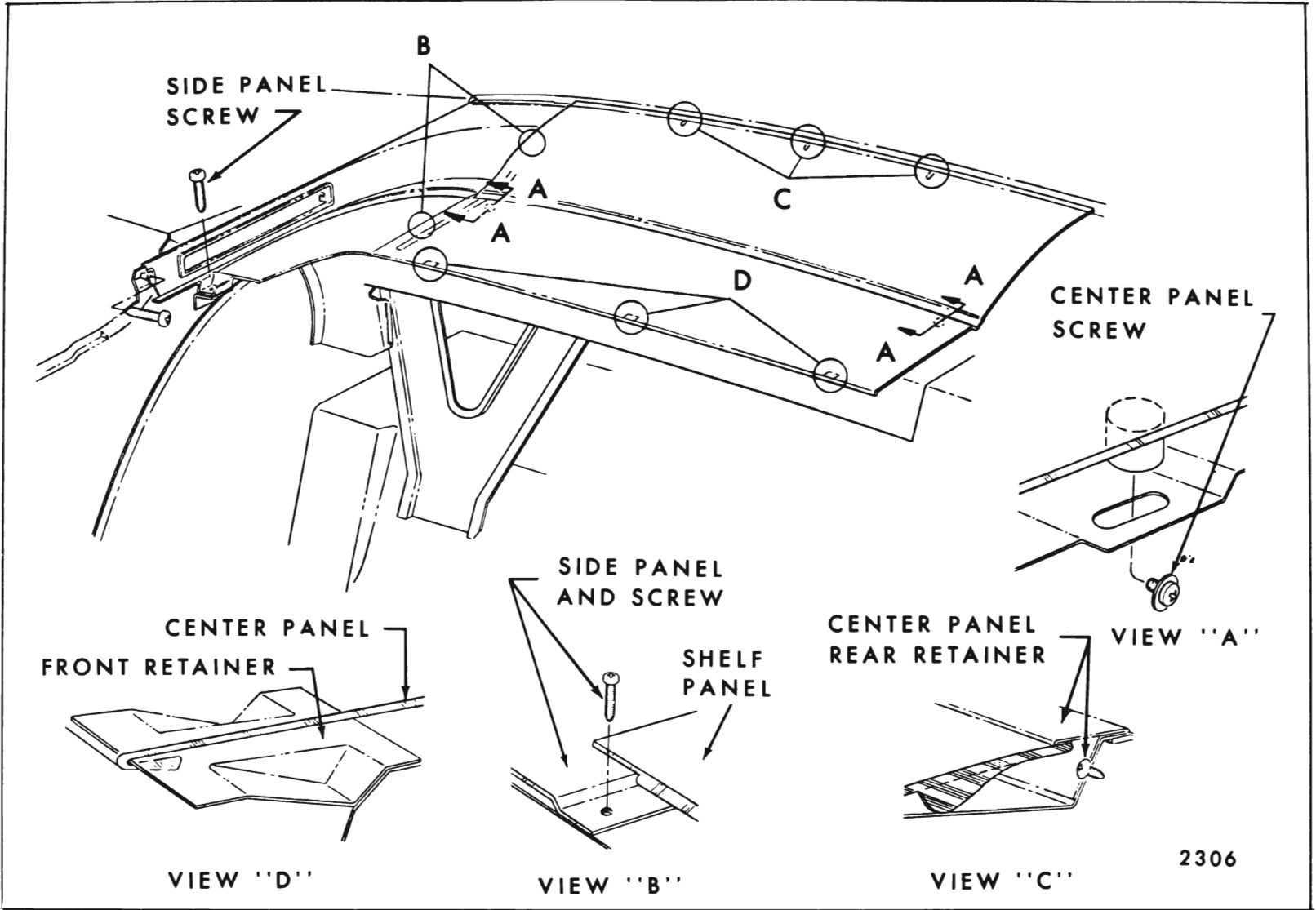

Fig. 8-13—Compartment Shelf Trim - Oldsmobile "E" Body

4. With a suitable flat-bladed tool, carefully disengage trim retainers from rear quarter inner panel along leading edge of rear body lock pillar (on front edge of rear quarter front trim assembly). (Fig. 8-17).

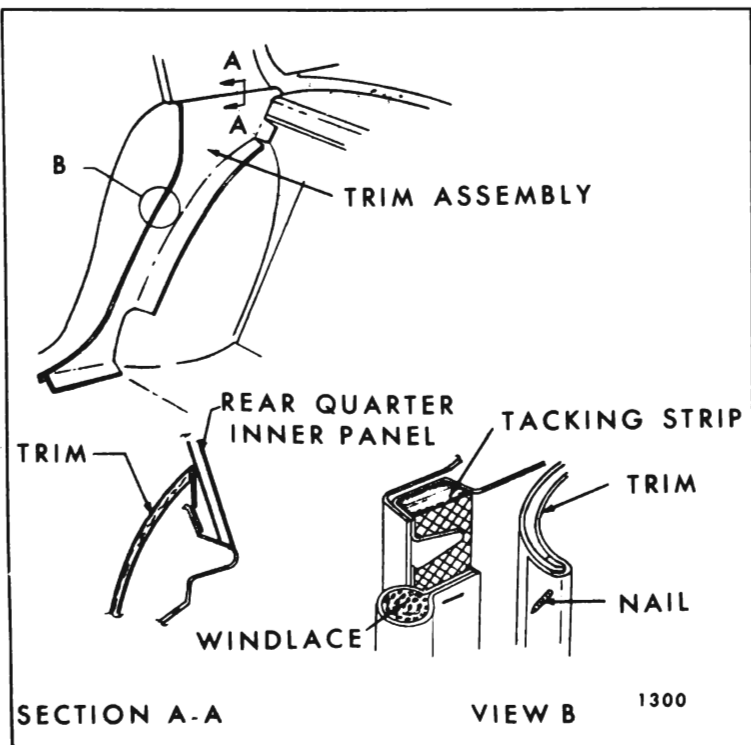

Fig. 8-14—Rear Quarter Lower Trim Assembly - "B&C" Body "39 and 69" Styles

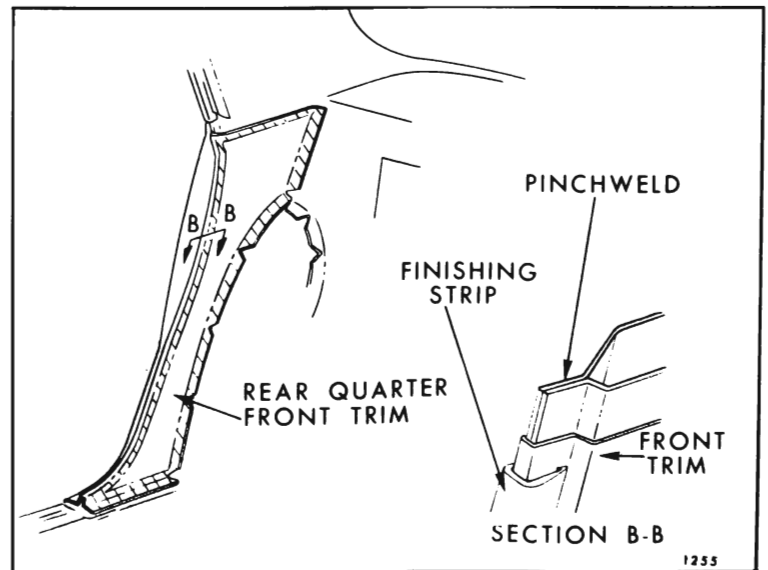

Fig. 8-15—Rear Quarter Trim Assembly - Oldsmobile 33839, 69 and Buick 44439 Styles

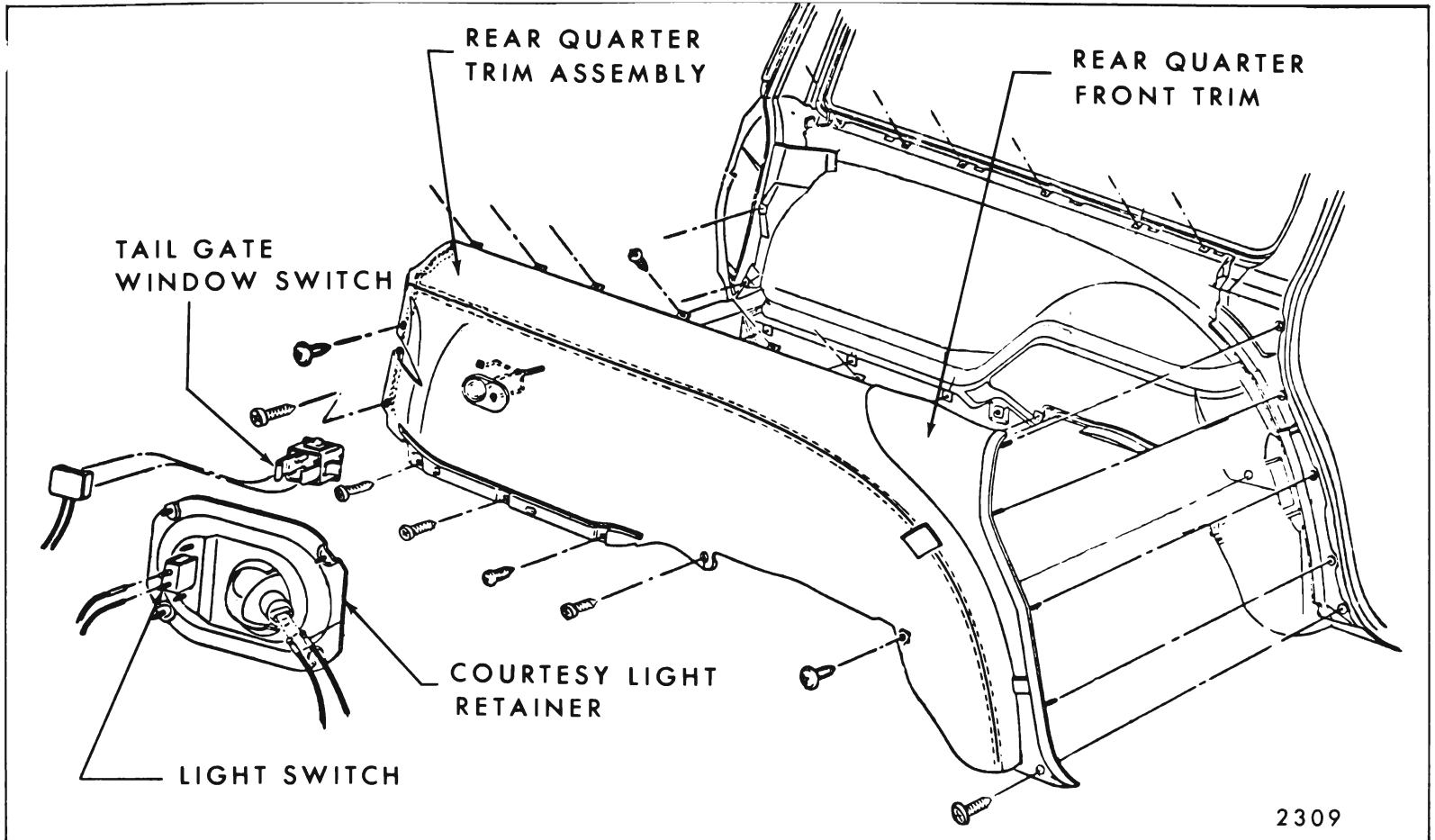

Fig. 8-16—Rear Quarter Trim Panel Left Side - "B" Station Wagons

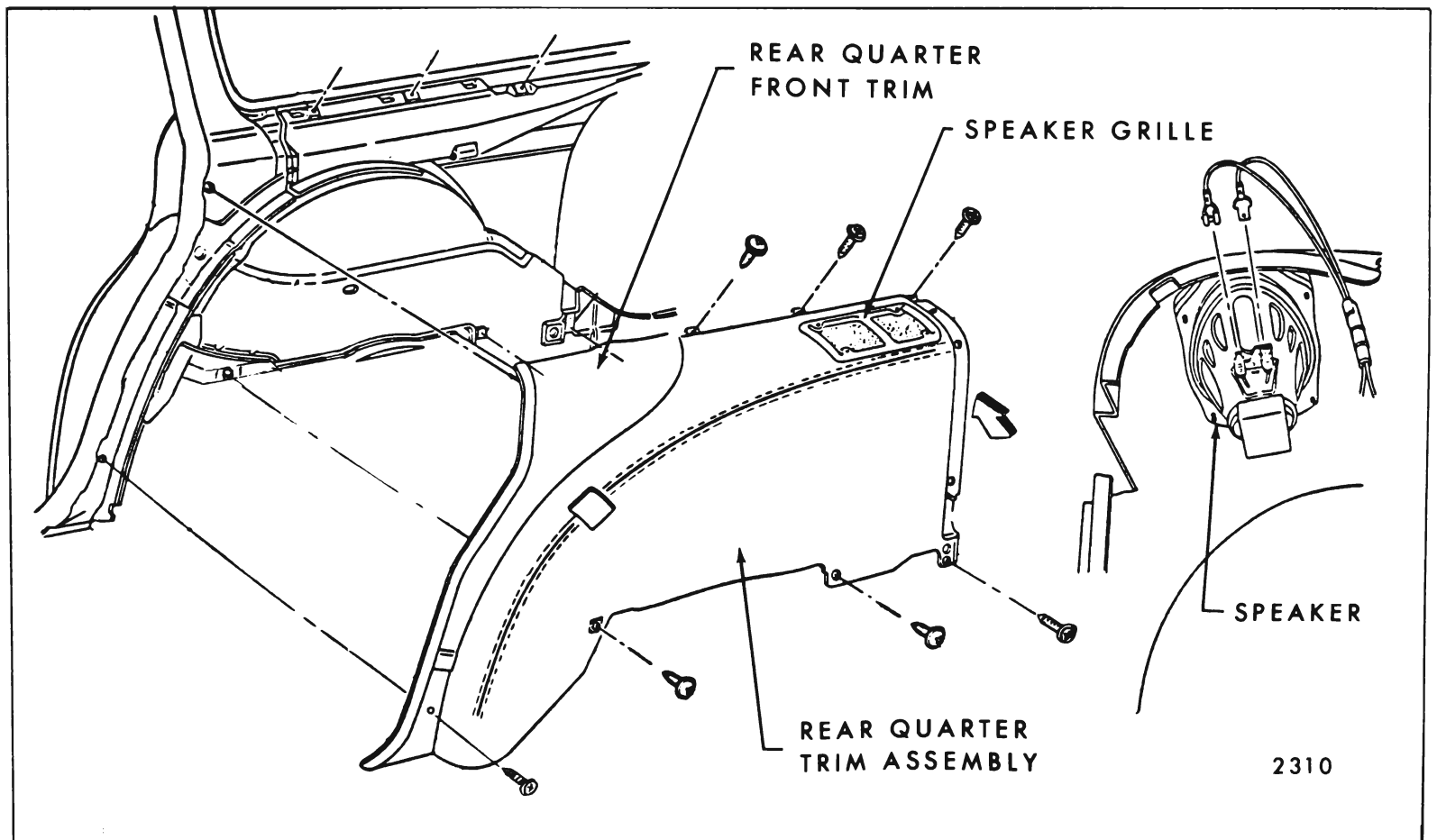

Fig. 8-17—Rear Quarter Trim Panel Right Side - "B" Station Wagons

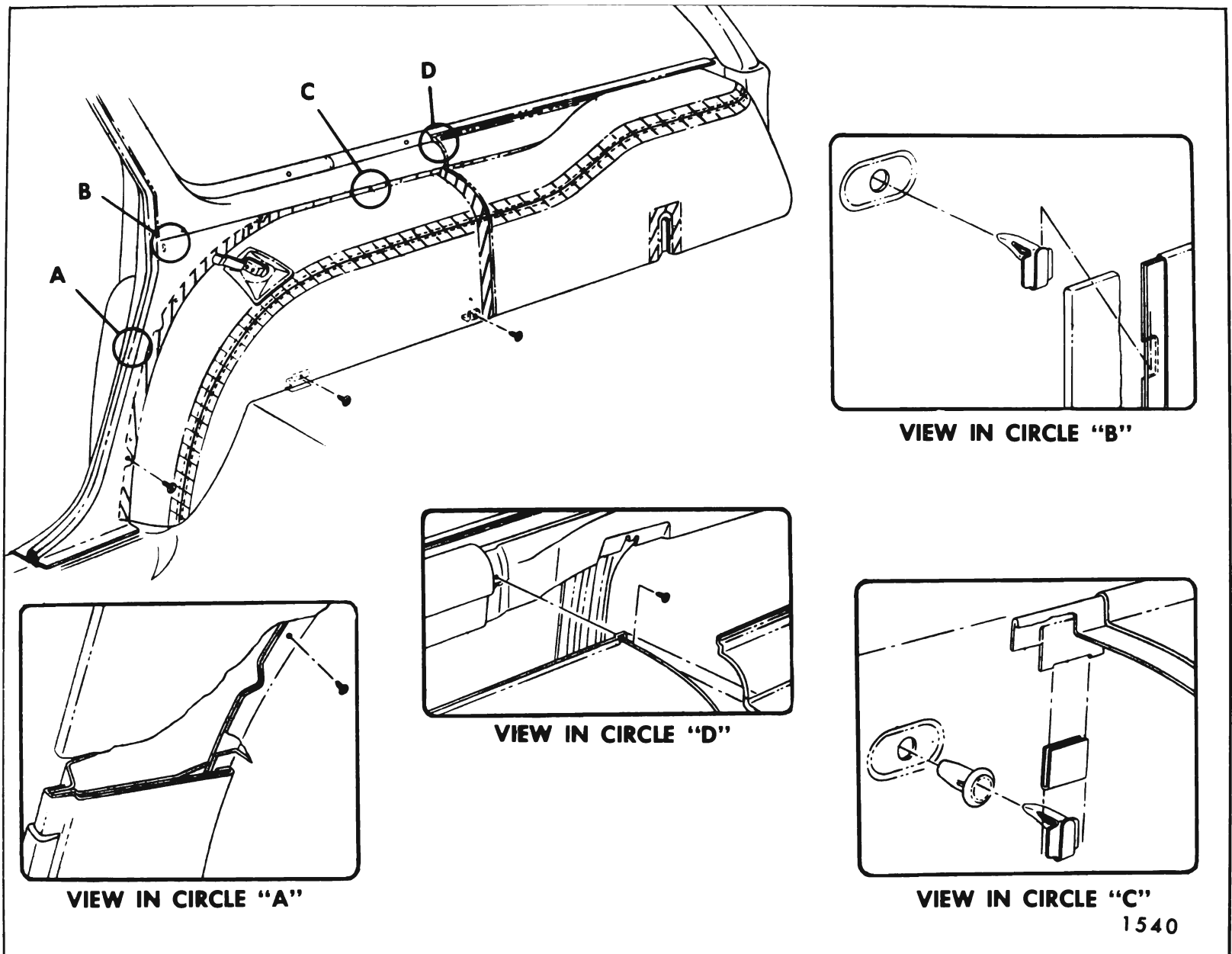

Fig. 8-18—Rear Quarter Trim Panel, Right Side - "A" Station Wagons

5. Remove spare tire cover support.
6. Lift assembly upward slightly to disengage from rear quarter inner panel and remove assembly from body.
7. To install, reverse removal procedure.

REAR QUARTER FRONT TRIM PANEL (RIGHT OR LEFT SIDE)— "A" BODY STATION WAGONS

Removal and Installation

1. Disengage pinchweld finishing strip along rear body lock pillar and remove rear door sill plate.
2. Remove exposed screw at lower end of trim panel (see Fig. 8-18 and 8-19).

3. With a flat bladed tool, disengage trim retaining clips from quarter inner panel (see View "B" in Fig. 8-18).
4. Carefully swing rear edge of trim assembly forward to break cement bond at body lock pillar and remove rear quarter front trim panel from body.
5. To install, reverse removal procedure. Prior to installation of pinchweld finishing strip, cement forward edge of trim assembly to out-board surface of body lock pillar pinchweld flange (see View "C" in Fig. 8-19).

SPARE TIRE COVER PANEL— "A" BODY STATION WAGON STYLES

Removal and Installation

The spare tire cover panel is retained at belt line

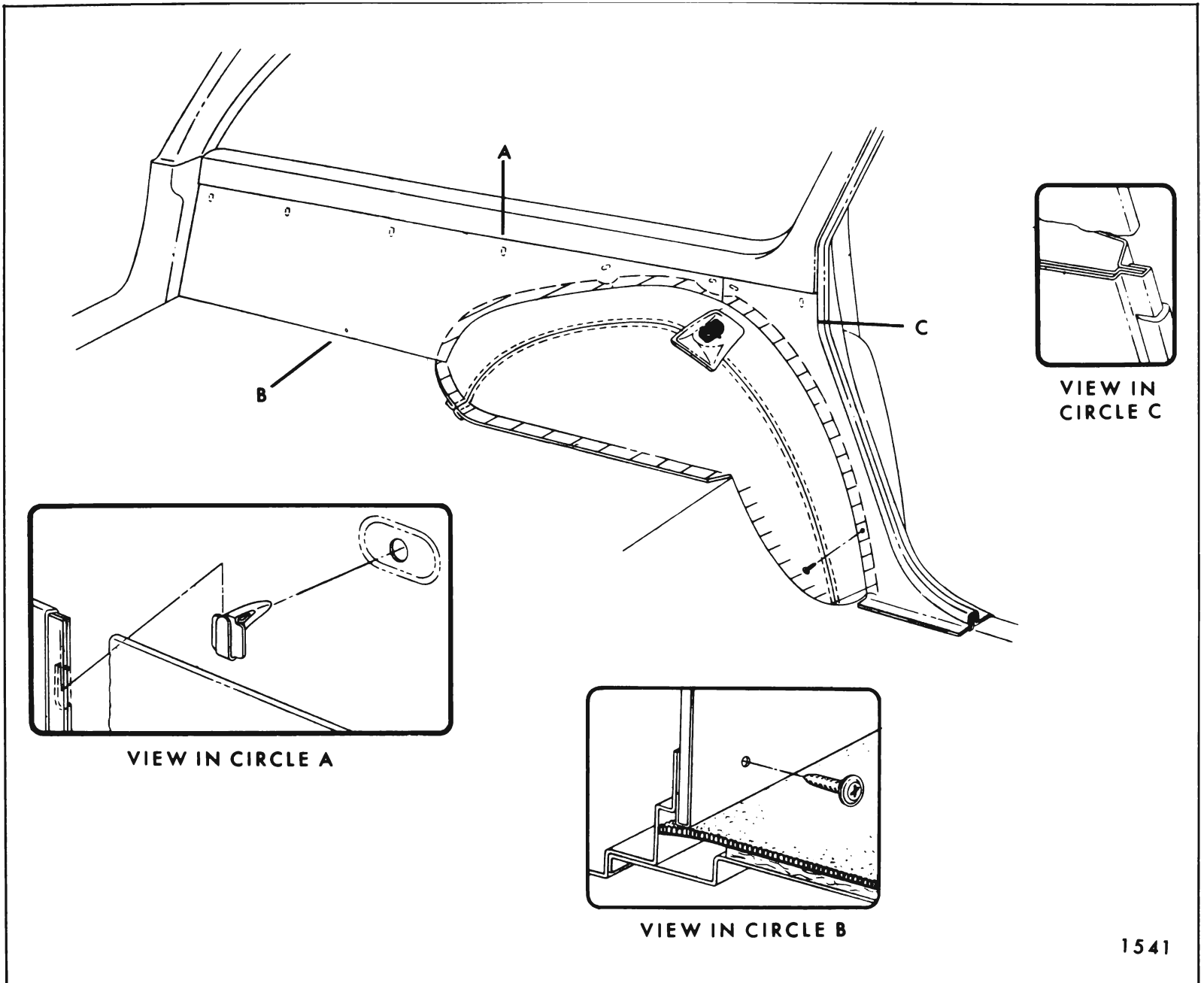

Fig. 8-19—Rear Quarter Trim Panel, Left Side - "A" Station Wagons

by a screwed-on garnish molding and at the load floor level by a folding (catch-type) handle. To remove cover, open catch handle and swing bottom edge of assembly upward to disengage upper edge from beneath garnish molding (see Fig. 8-18). To install, reverse removal procedure.

WHEELHOUSE TRIM COVER PANEL (RIGHT SIDE)—ALL "A" BODY STATION WAGON STYLES

Removal and Installation

1. Remove rear quarter front trim panel and spare tire cover panel.
2. Remove second folding seat back catch and bumper assembly from wheelhouse.
3. Remove all trim attaching screws at front,

rear and bottom of wheelhouse trim cover (See Fig. 8-18).

4. With a putty knife, or other suitable flat bladed tool, disengage trim retaining clips from sealing plugs along top of wheelhouse cover panel and remove panel from body (see View "C", in Fig. 8-18).

NOTE: The trim retaining clips and corresponding plastic sealing plugs are available as service parts.

5. To install, reverse removal procedure.

REAR QUARTER REAR TRIM PANEL—ALL STATION WAGON STYLES EXCEPT 13435 AND 23335 STYLES (LEFT SIDE)

Removal and Installation

1. On "35" styles, remove exposed screw at

bottom center of panel (see View "B" in Fig. 8-19).

2. Working from front to rear (with a flat bladed tool) disengage trim retaining clips from plastic sealing plugs along upper edge of rear quarter rear trim panel (see View "A" in Fig. 8-19).
3. With an upward movement, remove panel from body.
4. To install, reverse removal procedure.

WHEELHOUSE TRIM COVER ASSEMBLY (LEFT SIDE)—ALL "A" STATION WAGON STYLES EXCEPT 23335 STYLES

Removal and Installation

1. Remove rear quarter front and rear trim panel assemblies and second folding seat back bumper assembly.
2. On "35" styles, fold back rubber mat from wheelhouse. On "55 and 65" styles, remove compartment side filler panel as described in the "Seat" section of the body service manual.
3. Beginning at outer edges and working toward center, carefully break cement bond between wheelhouse and trim cover and remove cover.
4. To install, reverse removal procedure. Prior to installation, clean off old cement from wheelhouse to assure a smooth cementing surface. Install cover in position and scribe line inside of folding seat back bumper cut-out to guide installation when adhesive is applied. Remove cover and apply trim adhesive over wheelhouse surfaces contacted by trim cover (Do not cover scribe lines). With trim cover "inside-out", align bumper cut-out with scribe lines on wheelhouse. Apply cover to wheelhouse working from center of cover towards outer edges.

REAR QUARTER REAR TRIM PANEL (LEFT SIDE)—CHEVROLET 13435 AND PONTIAC 23335 STYLES

The rear quarter rear trim panel on these styles (left side) is constructed of a textured metal finish and extends to include the wheelhouse; all in a single panel.

Removal and Installation

1. Remove rear quarter front trim panel and second folding seat back bumper assembly from wheelhouse.

2. Remove all screws at front, rear and bottom of rear trim panel (see Fig. 8-20).

3. Working from front to rear (with a flat bladed tool), disengage trim retaining clips from plastic sealing plugs and remove trim assembly from body (see View "D" in Fig. 8-20).

NOTE: The trim retaining clips and corresponding plastic sealing plugs are available as service parts.

4. To install, reverse removal procedure.

REAR QUARTER REAR TRIM PANEL— CHEVY II STATION WAGONS

Removal and Installation

1. Remove rear quarter belt finishing moldings (front molding only right side). Disengage pinchweld finishing strip from rear body lower lock pillar pinchweld flange. Carefully break cement bond between overlapping edge of trim assembly and pinchweld flange.

2. Remove screws at front and rear of rear trim panel and remove trim panel from body.

NOTE: On styles with electric tail gate dropping window, remove screws securing window switch in left rear trim panel and disconnect switch from feed wire connector before removing trim panel from body.

3. To install, reverse removal procedure. Prior to installation, apply trim cement to pinchweld flange surface contacted by overlapping forward edge of trim assembly to assure good retention.

REAR QUARTER FRONT TRIM PANEL— CHEVY II STATION WAGONS

Removal and Installation

1. Remove front screw on rear quarter rear trim panel. Disengage pinchweld finishing strip from rear body lower lock pillar pinchweld flange. Remove rear door sill plate extension.

2. Carefully break cement bond between overlapping edge of front trim panel and pinchweld flange. Remove front trim panel attaching screws and remove trim panel from body.

3. To install, reverse removal procedure. Prior to installation, apply trim cement to pinchweld flange surface contacted by overlapping edge of trim assembly to assure good retention.

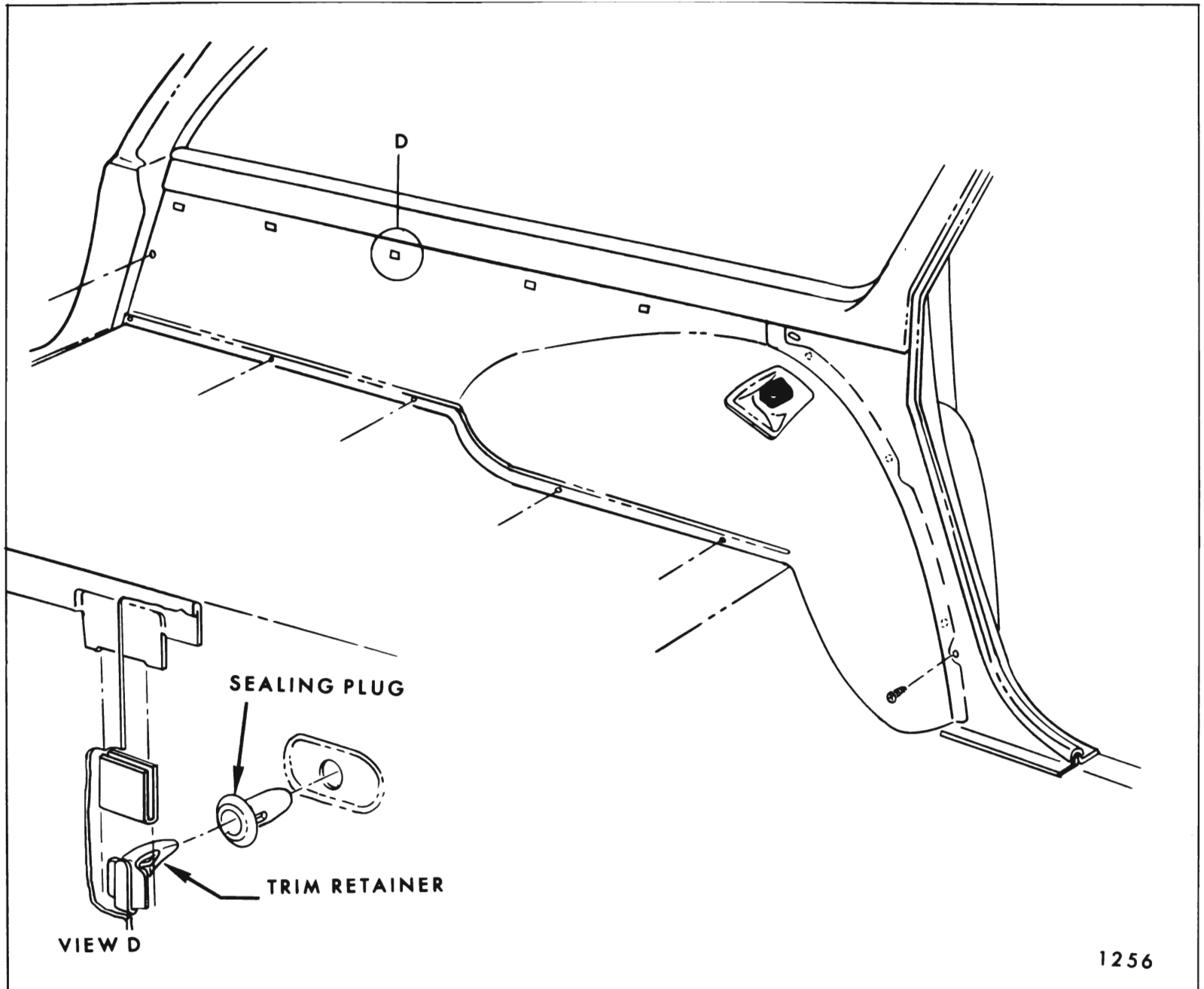

Fig. 8-20—Rear Quarter Trim Panel, Left Side - Pontiac 23335 Style

REAR QUARTER WHEELHOUSE TRIM COVER— CHEVY II STATION WAGONS

Removal and Installation

1. Remove second folding seat back filler panel. Remove the rear quarter front and rear trim panels.
2. Remove screws securing second folding seat back retainer and support and remove retainer and support from wheelhouse.
3. Carefully break cement bond between wheelhouse trim cover and wheelhouse panel and remove trim cover from body.
4. To install, reverse removal procedure. Prior to installing wheelhouse trim cover, apply neoprene type weatherstrip adhesive, 2" wide, completely around inside perimeter of wheelhouse trim cover. Also, apply weatherstrip adhesive to area around cut-out for second seat back support on wheelhouse. Position trim assembly to wheelhouse and apply, working material down and outwards to remove wrinkles. Install previously removed parts.

1256

REAR QUARTER STATIONARY WINDOW GLASS "A & B" STATION WAGONS

DESCRIPTION

The rear quarter window glass is retained in the body opening by adhesive caulked material. The extended method is to be used when replacing a rear quarter window glass. Procedures covering the removal and replacement of adhesive caulked glass including cutting out of material, necessary service parts, application of material, watertesting and waterleak repairing are described in the General Information Section. Specific details applying to rear quarter window glass removal and installation will be covered in this section.

REMOVAL

1. Remove glass as outlined in General Information Section. If the original glass is to be re-used, place it on a protected bench or holding fixture and remove old caulking material from glass with sharp scraper or razor blade. Remove all remaining traces with toluene or thinner dampened cloth.

NOTE: Do not use an oil base solvent. Any trace of oil will prevent adhesion of new caulking material to glass.

2. Using a sharp scraper or chisel, remove major portion of old caulking material from pinchweld flange around rear quarter window opening. It is not necessary that all material be removed, but there should not be any loose pieces left in the opening.

INSTALLATION

1. Check all reveal molding retaining clips. If upper end of a clip is bent away from body metal more than 1/32 of an inch, replace or reform clip to insure adequate molding retention.

NOTE: Check all clip attaching screws and tighten as required.

2. With black weatherstrip adhesive cement four flat spacers (.20 x .63 x 1.0 - Part No. 4459429 or equivalent) to pinchweld flange; two at top and two at bottom (see Fig. 8-21).
3. With black weatherstrip adhesive cement four rectangular spacers (.34 x .44 x 1.0 - Part No. 4871330 or equivalent) to rear quarter window opening rabbet; two at sides and two at bottom (see Fig. 8-21). Both side spacers should be cemented in the approximate position indicated in Figure 8-21.

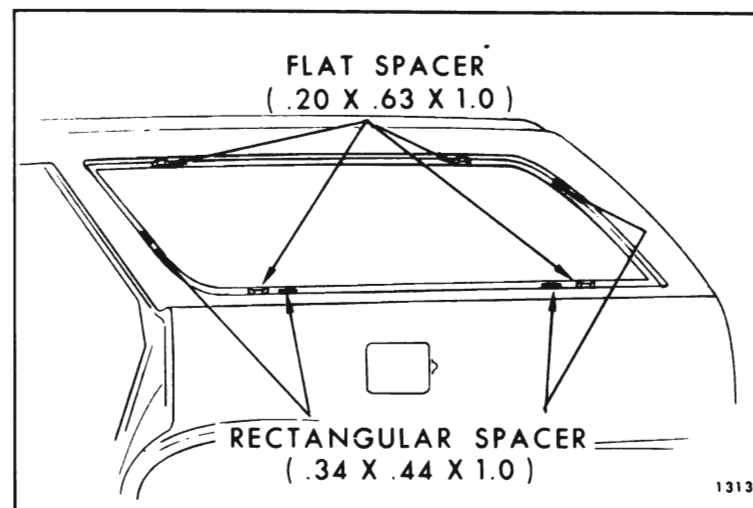

Fig. 8-21—Rear Quarter Window Spacer Installation

4. Position glass in opening by making contact along upper edge first and then swing in lower edge (see Fig. 8-22 and 8-23).
5. Check relationship of glass to pinchweld flange around entire perimeter. Overlap of pinchweld flange by glass should be equal with a minimum overlap of 3/16". Inadequate overlap across top may be corrected by replacing two rectangular glass support spacers across bottom with thicker spacers.
6. Check relationship of glass contour to body opening. Gap space between glass and pinchweld flange should be no less than 1/8" nor more than 1/4". If difficulty is encountered staying between these limits, correction can be made by any one of the following methods:
 - a. Position another glass in opening to determine if a better fit can be obtained.

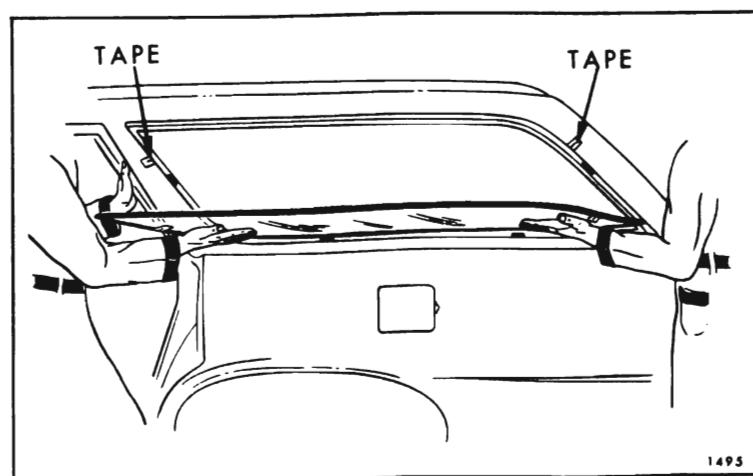

Fig. 8-22—Stationary Quarter Window Installation

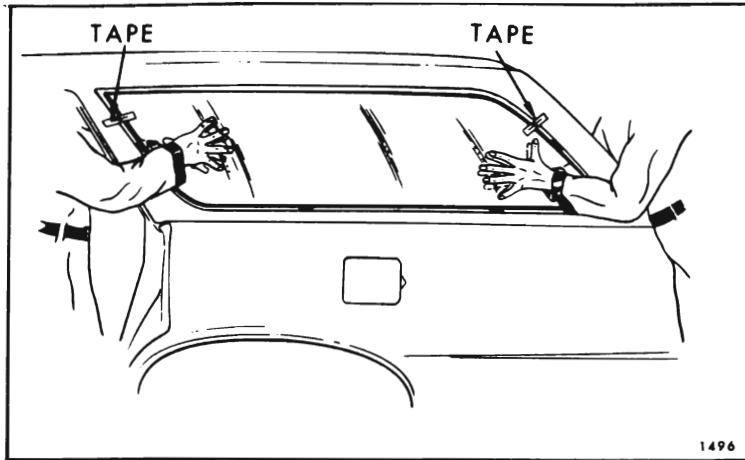

Fig. 8-23—Stationary Quarter Window Installation

- b. Rework pinchweld flange.
 - c. Apply more caulking material than is specified at excessive gap areas. Material can be applied to pinchweld flange or by allowing bead on glass to exceed specified $3/8''$ height at gap areas.
7. After final adjustments have been made and glass is in proper position, apply a piece of masking tape horizontally over front and rear edges of glass and body pillars (Fig. 8-23), so that tape on glass can be aligned with tape on body and act as a guide when glass is installed.
 8. Apply one inch masking tape completely around edge of glass inner surface $1/4''$ inboard from outer edge (see Fig. 8-24).
 9. From inside of body, apply masking tape around window opening to protect painted and trimmed surfaces.
 10. Using a clean, lint free cloth, liberally dampened with Adhesive Caulking Primer, briskly rub primer over and into original adhesive caulking material that remains on pinchweld flange. If the pinchweld flange has been repainted, prime flange with Paint Primer, or equivalent.
 11. Wipe surface of glass to which bead of adhesive caulking material will be applied (between masking tape and edge of glass) with a clean water-dampened rag. Dry glass thoroughly with a clean dry rag.
 12. With caulking gun and nozzle positioned as illustrated in Figure 8-24, carefully apply a smooth continuous bead of caulking material $3/8''$ high by $3/16''$ wide at base completely around inside edge of glass.

NOTE: When material in first tube is dispensed, quickly insert second tube and con-

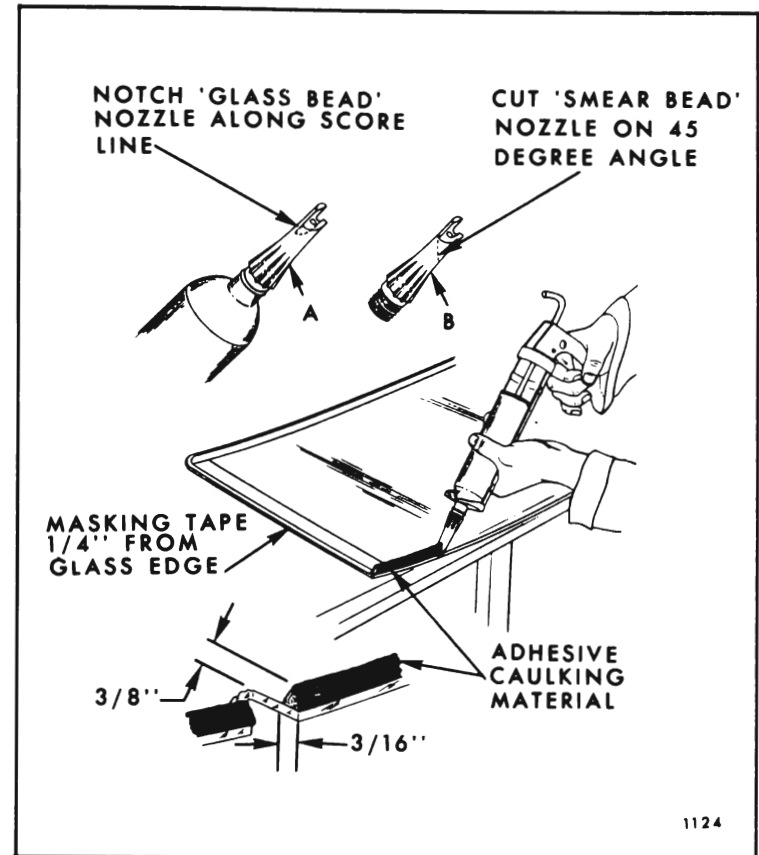

Fig. 8-24—Adhesive Caulking Material Application - Extended Method

tinue application of bead. This material begins to cure after fifteen (15) minutes exposure to air; therefore, perform the following steps immediately and install glass in the opening as quickly as possible.

13. Remove "glass bead" nozzle and insert "smear bead" nozzle. Holding caulking gun at an angle so that opening of nozzle rests flat on pinchweld flange, apply a thin ($1/4''$ wide x $1/16''$ high) "smear bead" of adhesive caulking material completely around pinchweld flange.
14. Install glass (see Fig. 8-22 and Fig. 8-23). Make certain that glass sets properly on spacers and does not have to be shifted after material contacts pinchweld flange. Align tape on glass with tape on body to guide window into opening.

NOTE: When setting glass in opening, make contact with upper edge of glass first and then swing in lower edge.

15. Press glass firmly to set caulking material. Use caution to avoid excessive squeeze-out of material.

NOTE: Glass handling suction cups may be used when removing or installing the rear quarter glass.

16. Inspect installation for proper seal between new caulking material and original material. If a gap is encountered, apply sufficient caulking material to fill the void. On inside of body run a flat stick around the pinchweld flanges to push excess caulking material back into opening between glass and flanges. Remove any excess squeeze-out of material.
17. Watertest installation immediately using cold water spray.
18. Remove masking tape from inside of glass.
19. Install reveal moldings, inside garnish moldings and previously removed parts.

REAR QUARTER STATIONARY WINDOW "X" STATION WAGON

REMOVAL

1. Remove rear quarter garnish moldings and rear quarter reveal moldings (see Molding section of Body Service Manual).
2. Remove quarter window upper and lower retainer and belt finishing molding supports.
3. Using a suitable tool, carefully break seal between window rubber channel and body opening. With the aid of a helper, carefully push glass and rubber channel assembly inboard and remove assembly from opening.

CAUTION: Use care so that glass does not strike body metal. Edge chips can cause solid tempered safety plate glass to shatter: Do not attempt to grind glass.

INSTALLATION

1. Clean off old sealer from rubber channel and

body opening to assure a smooth sealing surface.

2. Apply a bead of black weatherstrip adhesive into glass cavity in rubber channel and install rubber channel to glass.
3. Apply a ribbon of medium-bodied sealer completely around window opening.
4. Insert window assembly into opening and install upper and lower window retainers.
5. Using a pressure type applicator, apply weatherstrip adhesive (black) between glass and lip of rubber channel completely around outside of window.
6. Clean off excess sealer and replace previously removed parts.

REAR QUARTER HARDWARE

DESCRIPTION

As shown in the following rear quarter hardware drawings, the "closed" style rear quarter window assembly operates within glass run channels. On "hardtop" styles, nylon rollers, which are components of the lower sash channel or which are bolted directly to the window glass, operate within the window front and rear guides.

All side windows are frameless solid tempered safety plate glass. Therefore, use caution when handling window assemblies which may shatter if chipped or deeply scratched.

In order to perform any service operations in the rear quarter it is necessary to remove the rear quarter trim as specified in the preceding trim section (see index).

REAR QUARTER INNER PANEL SEALING

All rear quarter inner panels are sealed with one or a combination of water deflectors, access hole

covers, sealing plugs (or grommets) and body sealer. Service procedures for inner panel water deflectors are outlined in the "Front and Rear Door" section of this manual (see index). Figure 8-25 is typical of a water deflector installation.

Inner panel access hole covers are retained by a series of screws and sealed with body sealer. Usually, removal of either the water deflector or access hole cover will provide the clearance required for service procedures of rear quarter hardware. Whenever any seal has been disturbed, however, the area must be carefully resealed to prevent waterleaks. Body caulking compound is recommended for service sealing. Figure 8-26 illustrates quarter inner panel sealing on styles which use individual seals at all hardware attaching locations.

PHANTOM VIEWS

The following figures illustrate the rear quarter

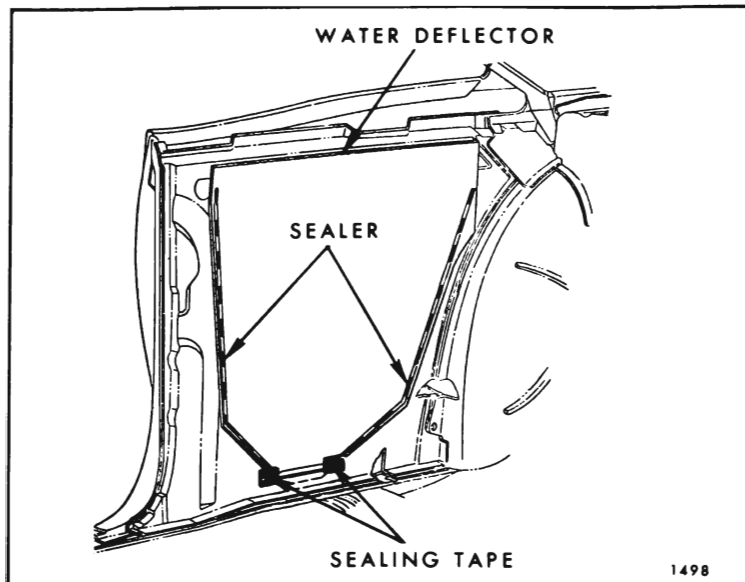

Fig. 8-25—Rear Quarter Inner Panel Sealing - Typical of Water Deflector Installation

hardware components and their relationship to each other on the various styles.

REAR QUARTER WINDOW "A & B-11" STYLES AND "A-07" STYLE

Removal and Installation

1. Remove rear quarter trim assembly and inner panel water deflector.

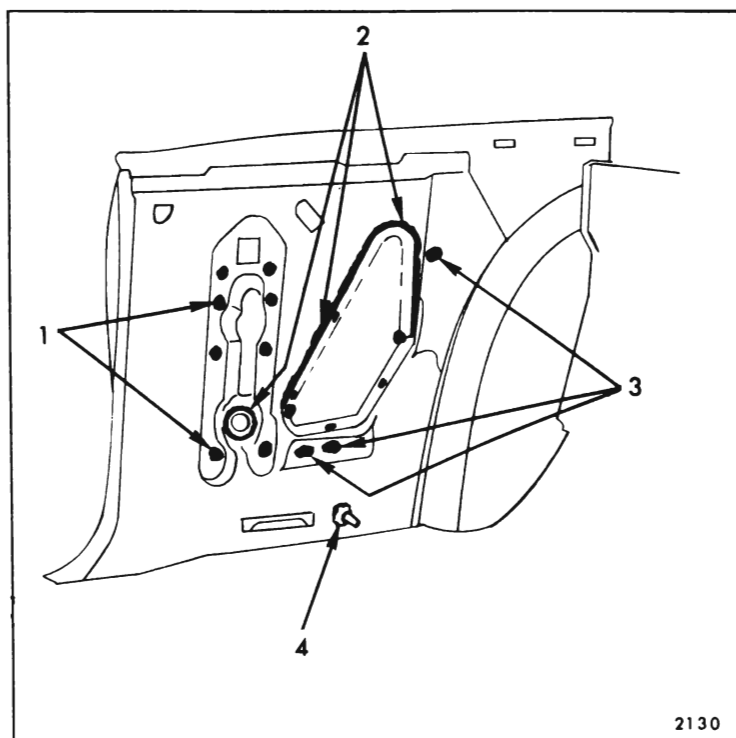

Fig. 8-26—Rear Quarter Inner Panel Sealing - "67" Styles

- | | |
|-----------------------------------|--------------------------------------|
| 1. Regulator Attaching Bolt Slots | 3. Window Guide Adjusting Stud Slots |
| 2. Access Hole Covers | 4. Electrical Harness Grommet |

2. On "A" styles, remove glass run channel outer strip assembly. Refer to index of "Front Door" section for strip assembly removal.
3. On "A & B" styles lower window to position shown in Figure 8-39 for "A-07" styles, 8-40 for "A-11" styles, and 8-41 for "B-11" styles.
4. Supporting window with one hand, disengage clip retainer securing regulator lift arm to pivot pin on window lower sash channel ("11" styles) or to lower edge of glass ("07" style).
5. Lower front edge of glass until nylon guide at top of window front vertical sash comes out of front glass channel and rear edge of glass comes out of rear run channel. Then, lift glass up (rear edge first) and remove window from body outboard of window opening.
6. To install, reverse removal procedure.

REAR QUARTER WINDOW—"X-11" STYLE

Removal and Installation

1. Remove rear quarter trim assembly and inner panel water deflector.
2. Remove glass run channel inner and outer strip assemblies (at belt). Refer to index of "Door" section for removal procedure.
3. With the window in the full up position, remove window support to regulator plate attaching screws (Fig. 8-42).
4. Operate window regulator down. Disengage window assembly from regulator arm and tilt rear of window downward to disengage window from glass run channels. Lift window upward and inboard and remove from body.
5. To install, reverse removal procedure.

REAR QUARTER WINDOW ADJUSTMENTS—"A & B" CLOSED STYLES

All window assembly adjustments are provided at the window regulator attaching screws.

1. To obtain proper seating of the glass in the upper glass run channels, or proper contact between belt sealing strips and lower sash channel, loosen regulator attaching screws and adjust window as required.
2. To eliminate a fore and aft bind between the glass run channels (hard operating window),

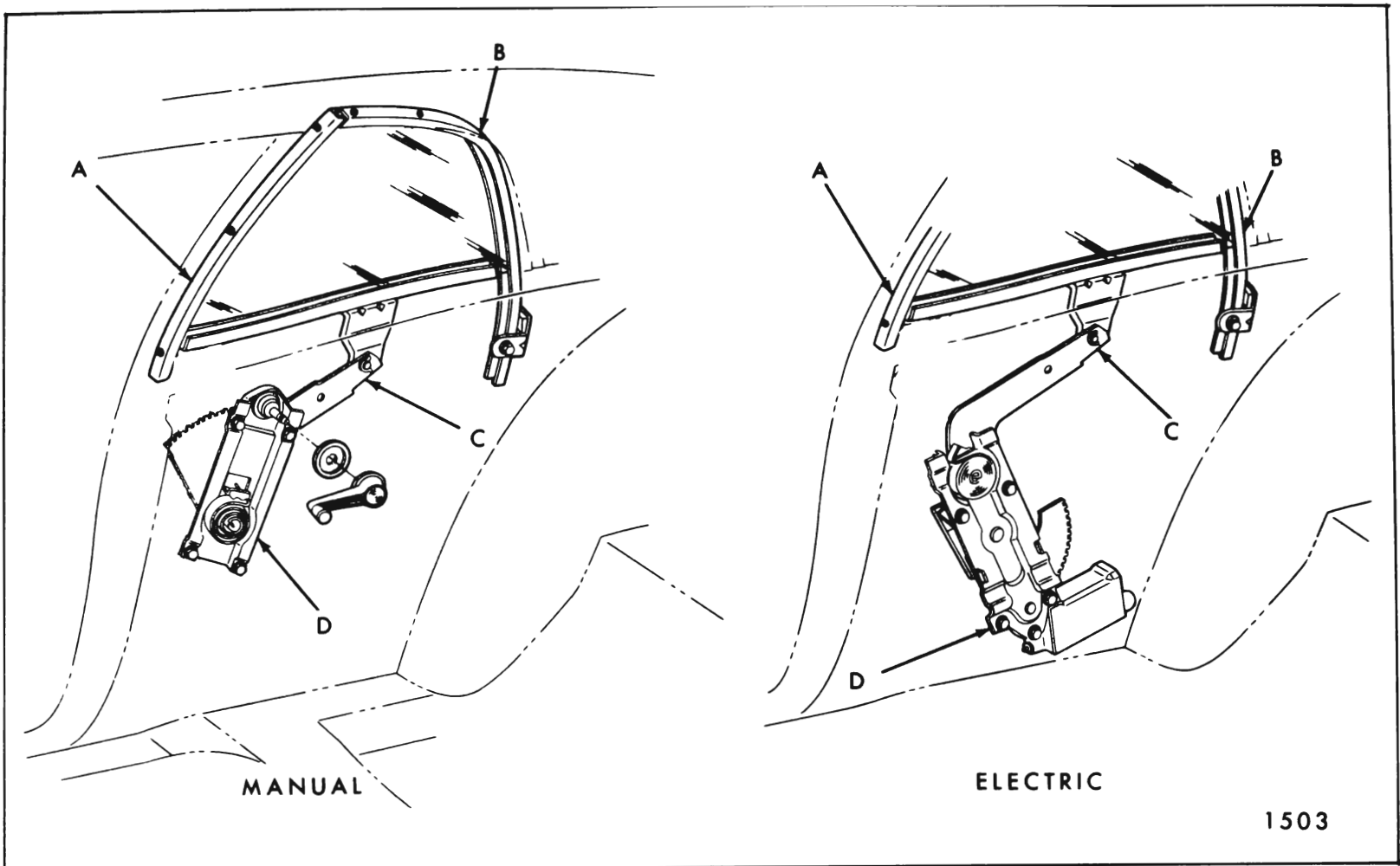

Fig. 8-27—Rear Quarter Window Hardware - "B-11" Styles

A. Front Glass Run Channel
B. Rear Glass Run Channel

C. Slotted Retainer
D. Window Regulator

or a condition where window will not stay in rear run channel, loosen rear run channel attaching bolt and adjust run channel fore or aft as required.

center guide lower attaching screw while forcing lower portion of guide rearward.

NOTE: Do not apply too much pressure when forcing guide rearward, as this tends to make front edge of glass dig into front run channel.

REAR QUARTER WINDOW ADJUSTMENTS—"X" CLOSED STYLES

For proper operation of rear quarter window and correct seating of glass in run channels, adjust rear quarter window in the following sequence:

1. With the window in the full "up" position, loosen the window support to regulator plate attaching screws and the center guide attaching screws.
2. Using hand pressure, press window upward and forward to make certain it is "bottomed" in the upper and forward glass run channels.
3. Tighten window support to regulator plate attaching screws and center guide upper attaching screw.
4. Lower window to full "down" position. Tighten

REAR QUARTER WINDOW REGULATOR (MANUAL AND ELECTRIC)—"A-B & X" CLOSED STYLES

Removal and Installation

1. Remove rear quarter trim assembly and inner panel water deflector. On electric styles, disconnect feed wire from regulator motor.
2. On "A & B" styles, disengage clip retainer from pivot pin on window lower sash channel (Fig. 8-41 for "B" styles, Figures 8-39 and 8-40 for "A" styles). Raise window to full-up and prop in that position.
3. On "X" styles, remove support to regulator plate screws (Fig. 8-42). Raise window to full-up and prop in that position.

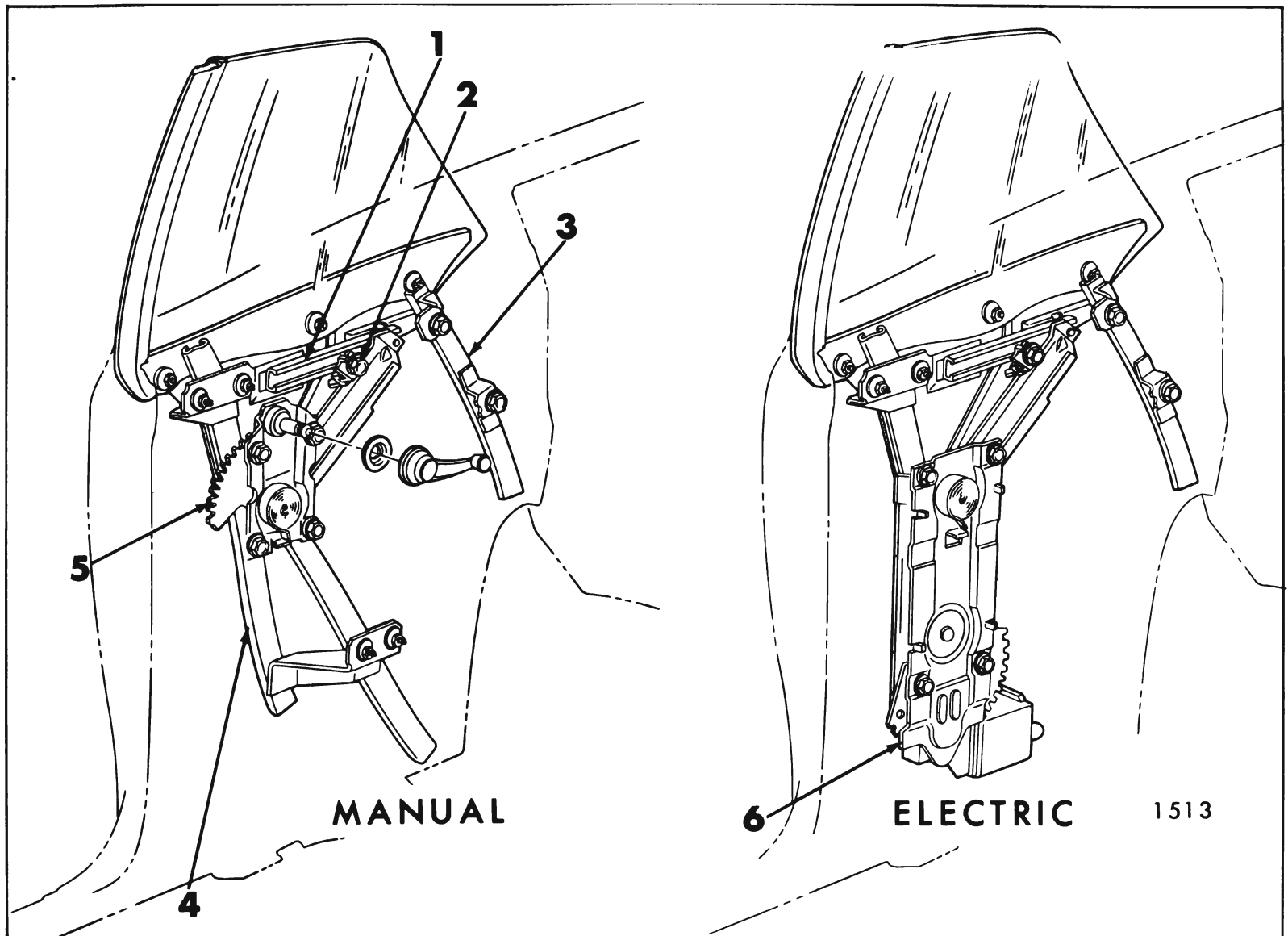

Fig. 8-28—Rear Quarter Window Hardware - "67 B-C" Styles Shown - "37-47-57" Styles Similar

1. Window Sash Channel Cam
2. Window Up-Stop

3. Rear Guide
4. Front Guide

5. Regulator (Manual)
6. Regulator (Electric)

4. On "A & B" styles, remove regulator to inner panel screws and remove regulator through large access hole (Fig. 8-43 - "A" styles shown, "B" similar).
5. On "X" styles, remove regulator to inner panel screws (Fig. 8-42). Disengage roller on regulator plate from window guide and remove regulator through large access hole.
6. To install, reverse removal procedure.

NOTE: The procedure for removing electric motor from regulator is described under "Door and Quarter Window Regulator Electric Motor Assembly" in the Door Section of this manual.

REAR QUARTER WINDOW REAR GLASS RUN CHANNEL—ALL CLOSED STYLES

Removal and Installation

1. Remove rear quarter window as previously described.

2. Remove run channel to inner panel attaching bolt (Fig. 8-44).
3. On "A-07" style remove screws securing run channel to side roof rail along length of run channel.
4. Using a flat blade tool, carefully pry run channel retaining clips from piercings in side roof rail.

NOTE: If difficulty is encountered disengaging run channel, inspect inside of channel for the presence of screws.

5. At belt line on "A" styles, disengage tab on rear run channel from side roof rail by moving run channel downward into opening between the panels; then, remove run channel from body.
6. Prior to installation, inspect foam sealing material for any damage, that would result in waterleaks, and replace as necessary.

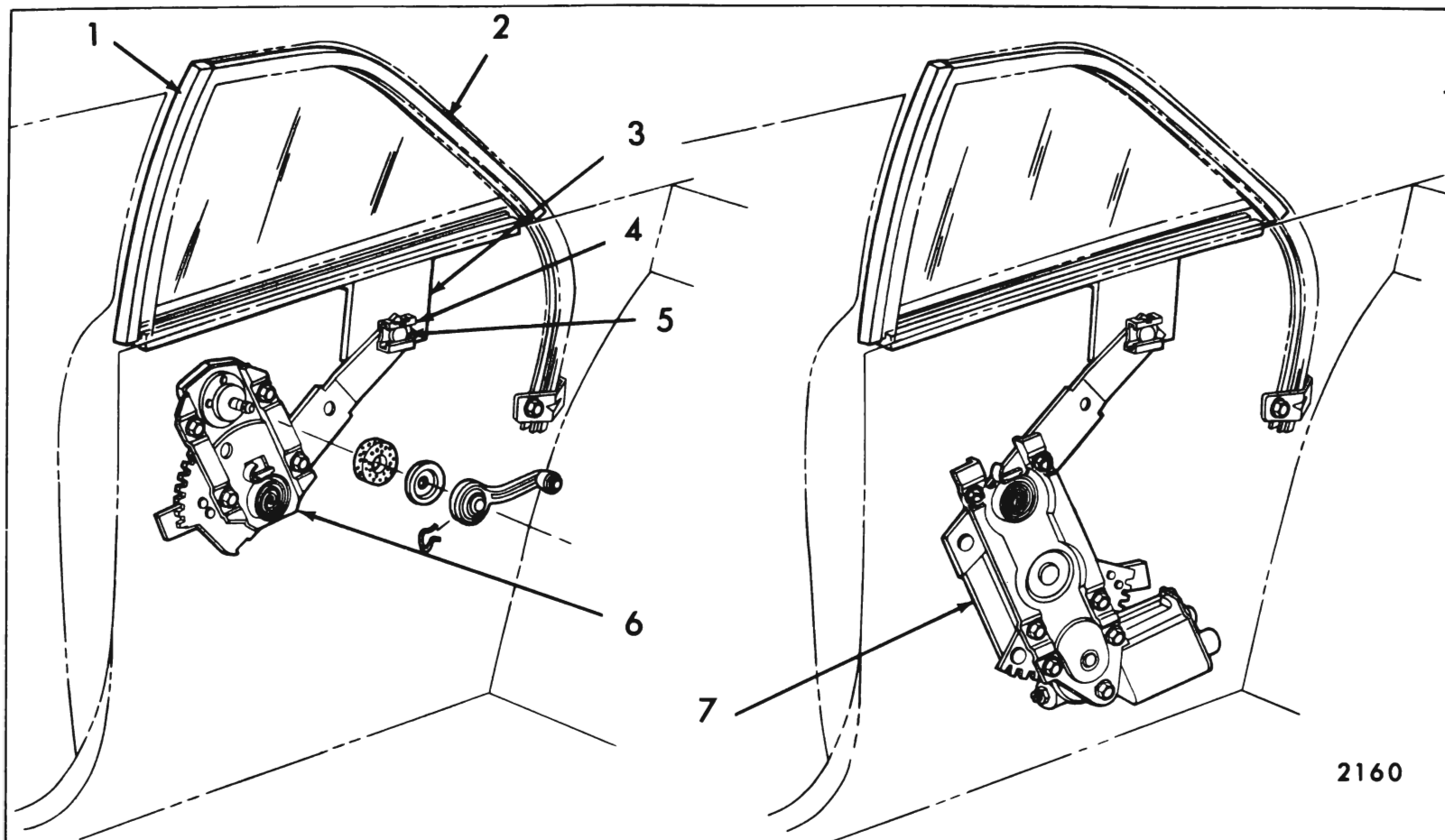

Fig. 8-29—Rear Quarter Hardware - "A-11" Style

1. Front Glass Run Channel
2. Rear Glass Run Channel

3. Window Lower Sash
4. Clip Retainer
5. Pivot Pin

6. Regulator (Manual)
7. Regulator (Electric)

7. To install, reverse removal procedure.

REAR QUARTER WINDOW FRONT GLASS RUN CHANNEL—ALL CLOSED STYLES

Removal and Installation

1. Remove rear quarter window as previously described.
2. On "A" styles, remove screws along length of run channel securing channel to body (Fig. 8-44).
3. On all styles, using a flat blade tool, pry run channel from body pillar and remove run channel (Fig. 8-45).
4. To install, reverse removal procedure. Prior to installation inspect sealing material on body pillar or run channel and replace or add to as required.

REAR QUARTER WINDOW GUIDE ASSEMBLY—"X-11" STYLES

Removal and Installation

1. Remove rear quarter trim assembly and trim finishing upper molding.
2. Detach inner panel water deflector sufficiently to gain access to guide attaching screws.
3. Remove guide attaching screws, disengage guide from roller on regulator arm and remove guide through access hole (see Fig. 8-46).
4. To install, reverse removal procedure.

REAR QUARTER WINDOW OUTER STRIP ASSEMBLY—ALL CLOSED STYLES

1. Remove rear quarter trim assembly and inner panel water deflector.
2. On "A & B" styles, disengage window assembly from regulator lift arm by removing slotted

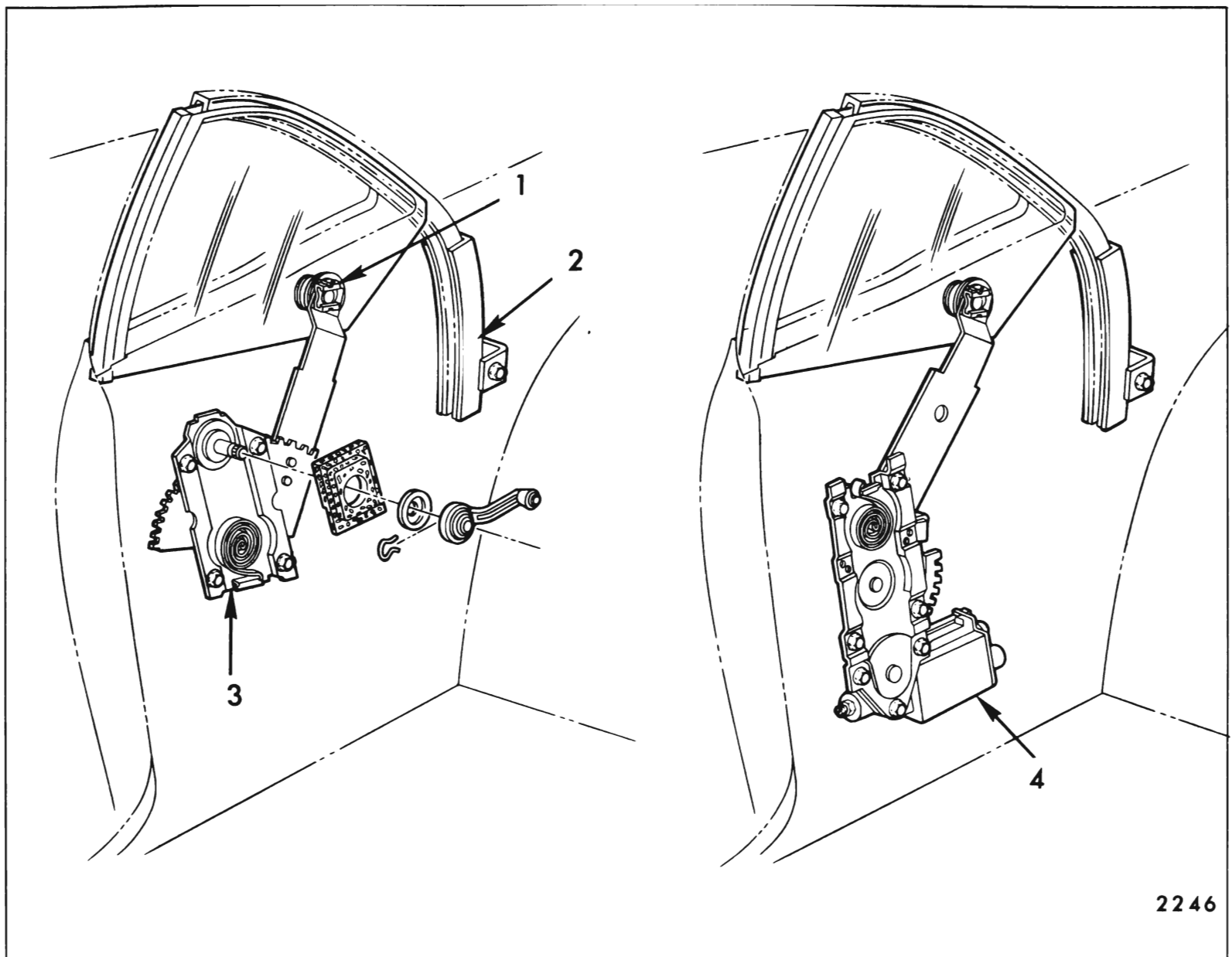

Fig. 8-30—Rear Quarter Hardware - "A-07" Style

1. Glass Retainer
2. Glass Run Channel

3. Window Regulator (Manual)
4. Window Regulator (Electric)

retainer (Fig. 8-41). On "X" styles remove support to regulator plate screws (Fig. 8-42).

3. Lower window assembly to bottom of rear quarter and rest it against outer panel.
4. On styles with screw retained strip assemblies, remove screws securing outer strip to rear quarter outer panel return flange and remove strip from body (Fig. 8-47). On styles with clip retained strip assemblies refer to index of "Door" section for removal procedure.

NOTE: Use care not to damage strip assembly or adjacent painted surfaces.

5. To install, reverse removal procedure.

REAR QUARTER WINDOW ASSEMBLY— "17-37-47-57-67 AND 87" STYLES

The rear quarter window is made of solid tempered safety plate glass. Consequently, it cannot be drilled or ground, or develop scratches or edge chips as it will shatter. The window assembly consists of a pressed-on front vertical sash channel and a bolt-on lower sash channel assembly.

NOTE: When reinstalling glass to sash channel bolts, or nylon roller nuts, torque to 60 inch pounds (5 foot pounds). Also, replace glass to sash channel spacers (rubber).

Refer to front of this section for hardware drawings which can assist in performing any of the following procedures. To perform any of these service

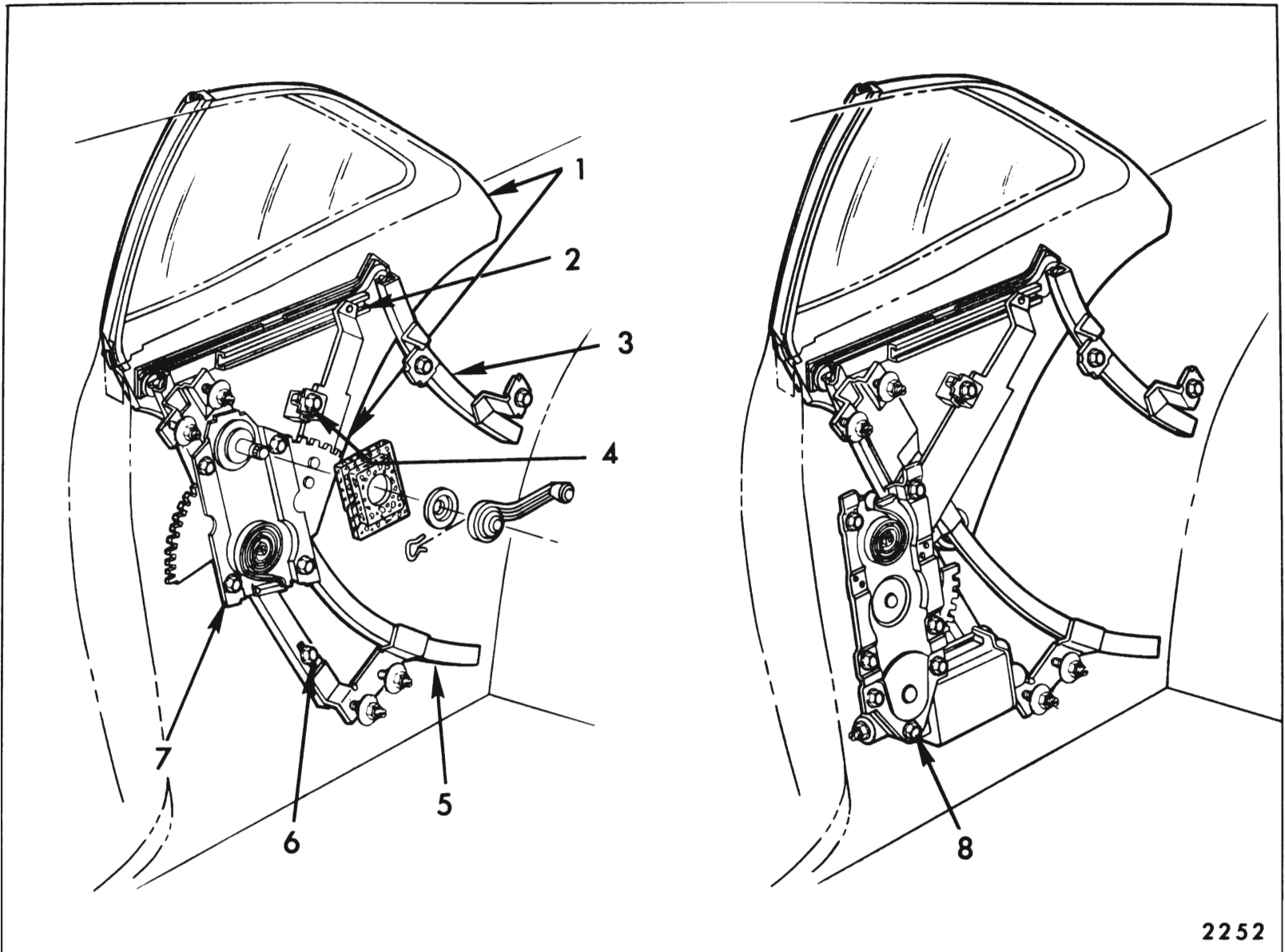

Fig. 8-31—Rear Quarter Hardware - "A-17" Style

1. Window Glass
2. Sash Channel Cam

3. Rear Guide
4. Up-Stop

5. Front Guide
6. Down-Stop

7. Window Regulator (Manual)
8. Window Regulator (Electric)

operations, remove rear quarter trim assembly and inner panel water deflector or access hole cover.

a. Removal and Installation "B-C 37 and 57" Styles

1. With window in full-up position, remove rear guide upper and lower adjusting stud nuts (Fig. 8-48). Disengage guide from roller on window lower sash channel and remove guide through access hole.
2. Lower window to almost full-down position to make lower sash channel cam attaching screws accessible through inner panel access hole (Fig. 8-48).
3. Loosen front guide upper adjusting stud nuts and remove front guide lower adjusting stud nuts (Fig. 8-48).
4. Remove lower sash channel cam attaching

screws (Fig. 8-48). Disengage cam from regulator lift arm roller and remove cam.

5. Manually raise window and remove it from between the panels by lifting upward and inboard.
6. To install rear quarter window, reverse removal procedure. Figure 8-49 is an exploded view of the rear quarter window assembly and identifies the various components and their assembly sequence.

b. Removal and Installation "B-47" Style

1. With window in full-up position, remove rear guide upper and lower adjusting stud nuts (Fig. 8-48). Disengage guide from roller on window lower sash channel and remove guide through access hole.

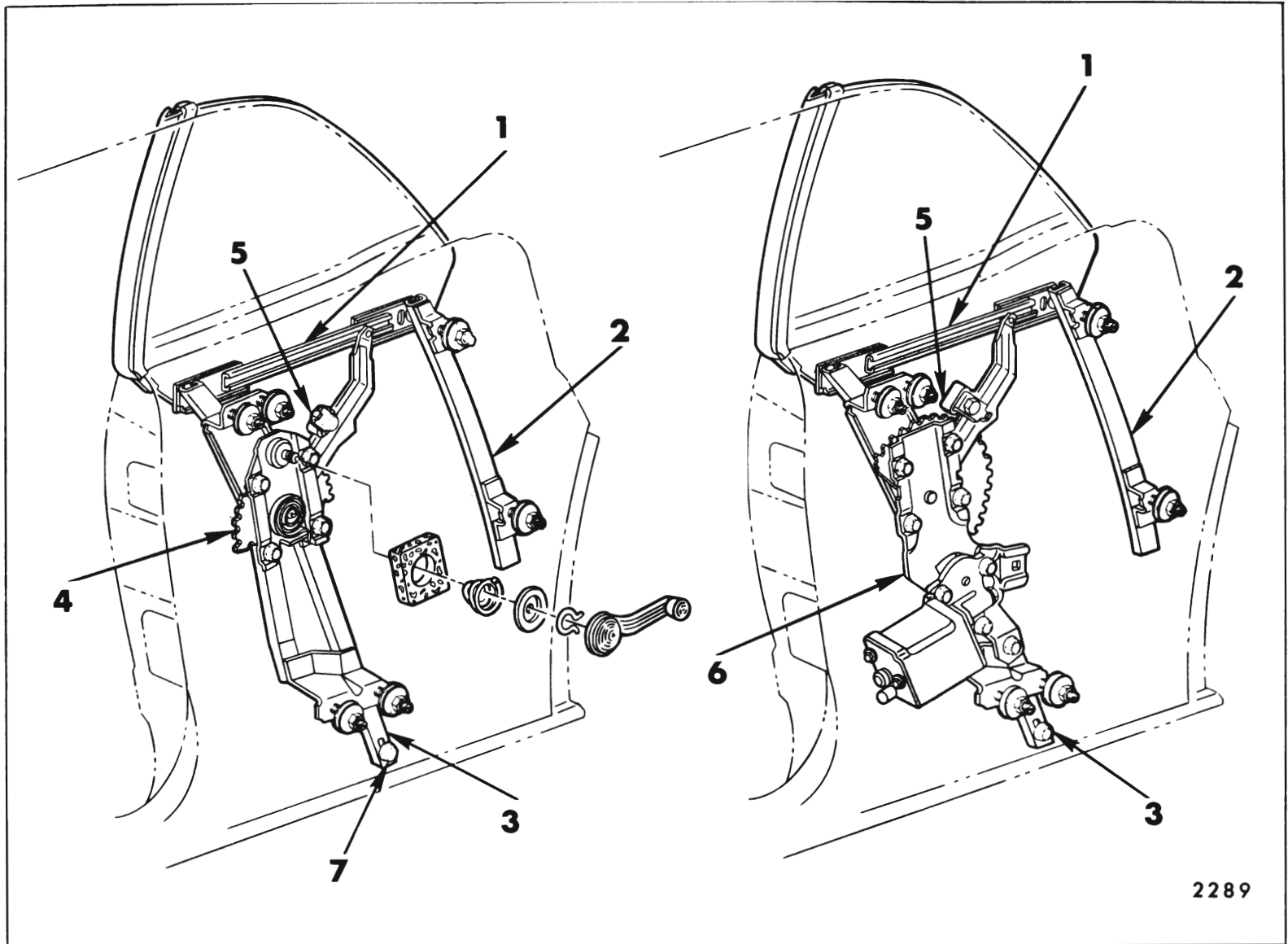

Fig. 8-32—Rear Quarter Hardware - "A-67" Styles

- | | | |
|---------------------|------------------------------|--------------------------------|
| 1. Sash Channel Cam | 4. Window Regulator (Manual) | 6. Window Regulator (Electric) |
| 2. Rear Guide | 5. Up-Stop | 7. Front Guide Lower Stop |
| 3. Front Guide | | |

2. With window lowered to half-down position, remove front guide lower adjusting stud nuts and loosen upper adjusting stud nuts (Fig. 8-48).
3. Disengage front guide lower studs from inner panel by pushing studs outboard. Disengage regulator lift arm from window lower sash channel cam at rear of cam by swinging guide and window assembly forward.
4. Supporting window assembly, drop front guide upper adjusting studs to bottom of the slots in the inner panel. Remove window from body by lifting window upward and inboard.
5. To install, reverse removal procedure. Figure 8-50 is an exploded view of the rear quarter

window assembly and identifies the various components and their assembly sequence.

c. Removal and Installation "B-C 67" Styles

1. Lower folding top.
2. Lower window to almost full-down position and remove lower sash channel cam attaching screws (Fig. 8-48). Disengage cam from regulator lift arm roller and remove cam.
3. Lift window straight upward and remove it from body.
4. To install rear quarter window, reverse removal procedure. Figure 8-49 is an exploded view of the rear quarter window assembly and identifies the various components and their assembly sequence.

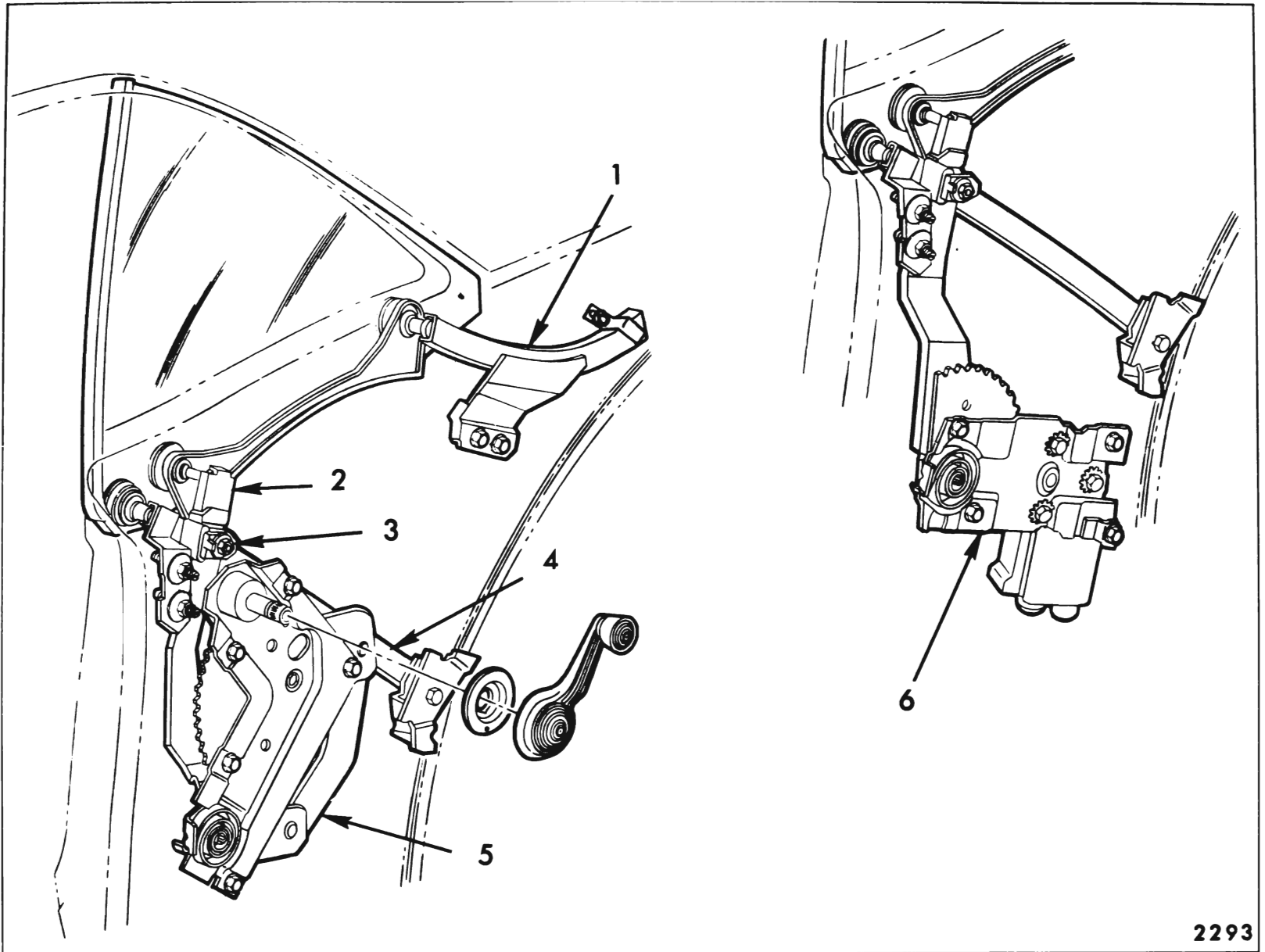

2293

Fig. 8-33—Rear Quarter Hardware - Buick "E" Styles

1. Rear Guide
2. Regulator Lift Arm Cam

3. Up-Stop
4. Front Guide

5. Regulator (Manual)
6. Regulator (Electric)

Adjustments—"B-C 37-47-57 and 67" Styles

1. Rear quarter window up-travel is determined by position of the window up-stop (Fig. 8-48). To change the window upper limits, loosen the stop attaching bolt and position the stop as desired.
2. Fore or aft position of the window is determined by the position of the front and rear guides. To adjust the window, loosen the front and rear guide adjusting stud nuts (Fig. 8-48) and reposition the window as required.
3. In or out adjustment of the window assembly, or only the top of the window, can be obtained by utilizing the front and rear guide adjusting studs (Fig. 8-48). To reposition the window in or out, adjust the guide upper and lower adjusting studs in the same direction. To adjust the

top of the window in or out, adjust the lower adjusting studs in the opposite direction of the upper studs.

d. Removal and Installation "A-17 and 67" Styles

1. Lower folding top on "67" styles.
2. Remove rear guide upper and lower attaching screws (Fig. 8-51 and 8-52). Disengage guide from sash channel roller and remove guide.
3. Remove glass run channel outer strip assembly (draft strip - see "Front Door" section of manual).
4. Remove the lower two adjusting stud nuts of the quarter window front guide and all but the top attaching bolt of window regulator (see Fig. 8-53).

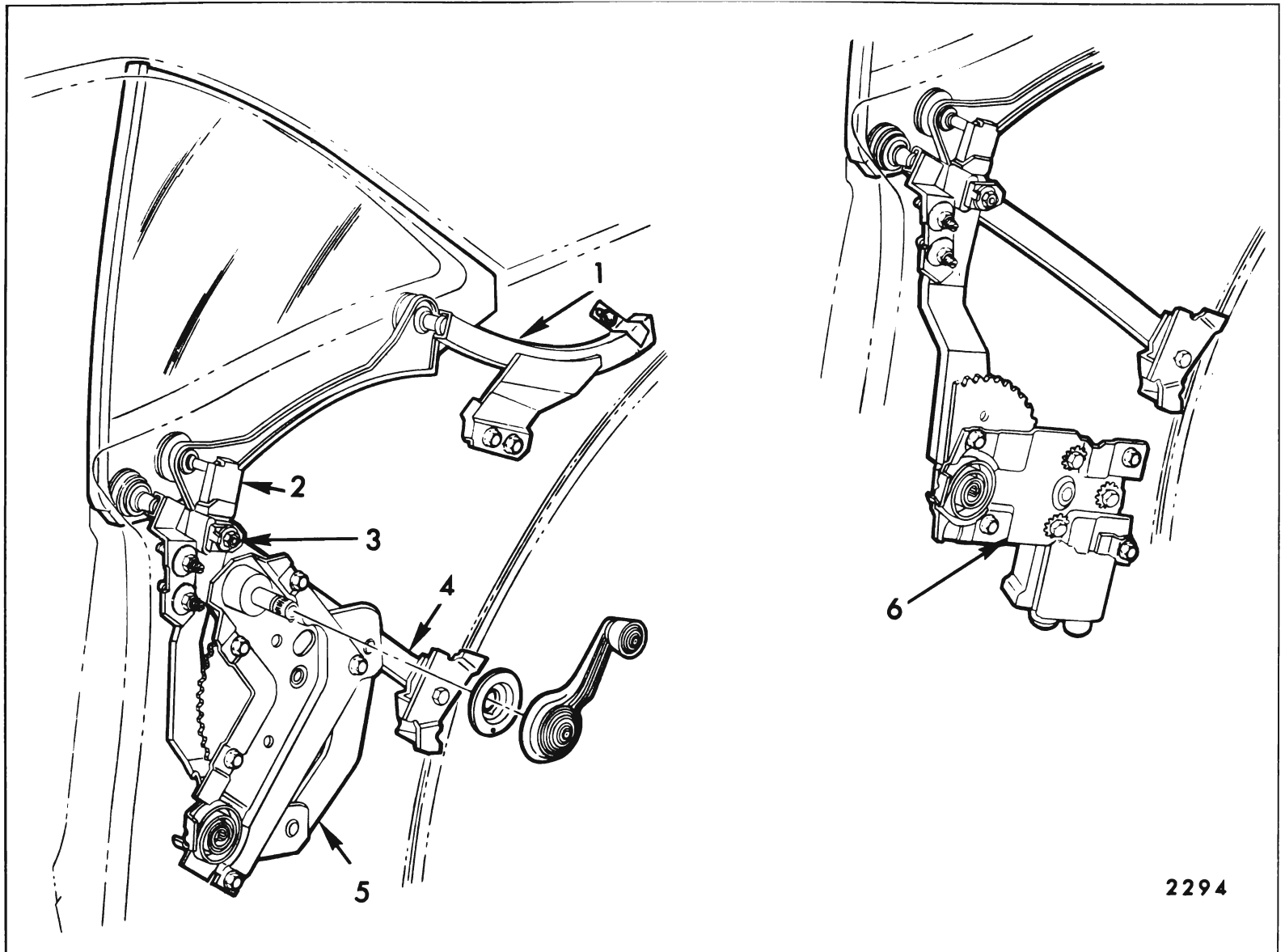

Fig. 8-34—Rear Quarter Hardware - Oldsmobile "E" Body

1. Rear Guide
2. Regulator Lift Arm Cam

3. Up-Stop
4. Front Guide

5. Regulator (Manual)
6. Regulator (Electric)

5. Rotate regulator counter-clockwise until lift arm roller is free of quarter window sash channel cam. Rotate rear edge of glass upward (outboard of side rail on "17" styles) and remove window (see Fig. 8-53).

NOTE: If additional clearance is needed (on "17" styles), the side roof rail weatherstrip can be detached at quarter window area.

6. To install, reverse removal procedure.

Adjustments—"A-17 and 67" Styles

To perform any rear quarter window adjustments, it is necessary to remove the rear quarter trim assembly.

1. To adjust window "fore or aft", loosen front

and rear guide adjusting stud nuts, position window and guides as required, and tighten nuts.

2. To adjust window "in or out" at belt line, loosen front guide upper adjusting stud nuts, adjust studs in or out as required, and tighten stud nuts.

3. To adjust top of window "in or out", loosen front guide lower adjusting stud nuts, adjust studs in or out as required, and tighten stud nuts.

4. To relieve a "fore or aft" binding condition between front and rear guides, loosen rear guide adjusting stud nut. Operate window to "full-down" position and tighten remaining stud nut.

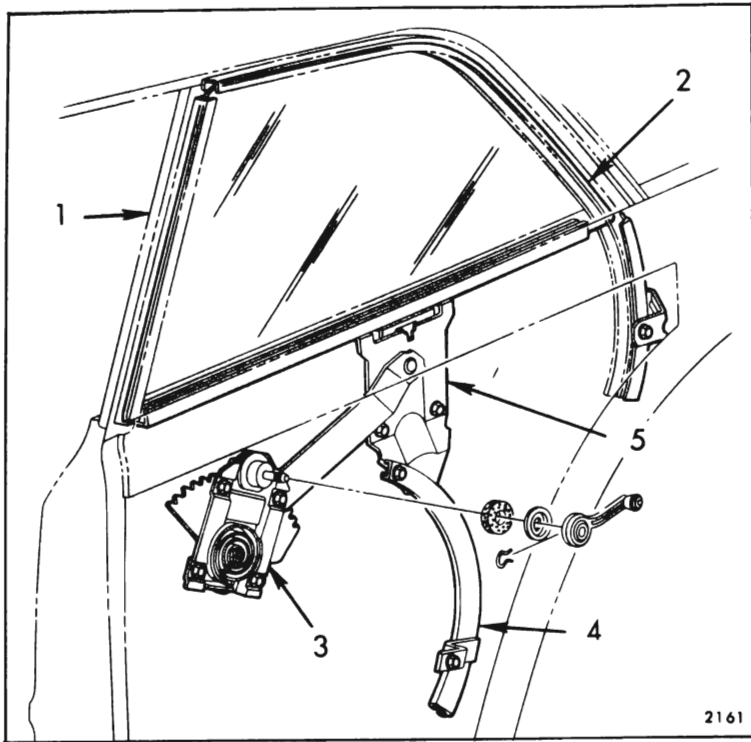

Fig. 8-35—Rear Quarter Hardware - "X-11" Style

- | | |
|----------------------------|----------------------|
| 1. Front Glass Run Channel | 4. Window Guide |
| 2. Rear Glass Run Channel | 5. Window Support to |
| 3. Window Regulator | Regulator Plate |

5. To limit up-travel of window, adjust window stop as required (see Figs. 8-52 and 8-51).

e. Removal and Installation All "E" Styles

1. With window in full-up position, remove rear guide upper and lower attaching bolts (Fig. 8-54). Disengage guide from roller on window assembly and remove guide through access hole.
2. With quarter window partially lowered (see Fig. 8-54), remove nuts securing regulator lift arm cam to regulator lift arm and remove cam.

NOTE: Lift arm must be pushed inboard slightly to remove cam.

3. While supporting glass, remove quarter window front guide attaching bolts and lower guide to bottom of rear quarter.
4. Remove quarter window inboard of roof panel.
5. To install, reverse removal procedure. Figure 8-55 is an exploded view of the quarter window assembly and identifies the various components and their assembly sequence.

Adjustments—All "E" Styles

Fore and aft alignment is determined by positioning

front guide. Adjusting rear guide will provide parallel condition of quarter window to door for constant seal. In or out alignment is determined by upper two adjusting studs and nuts at front guide. The adjustable up-stop will provide up or down alignment and partially fore and aft alignments by controlling window travel.

NOTE: Adjustments on regulator lift arm cam are provided to permit maximum travel but caution must be observed so not to interfere with quarter trim assembly at belt.

f. Removal and Installation "X-37" Style

1. With window in full-up position, remove rear guide upper and lower attaching bolts (Fig. 8-56). Disengage guide from roller on window assembly and remove guide through access hole.
2. Remove glass run channel inner and outer strip assemblies (draft strips) as outlined in the "Front Door" section of this manual - see index. Remove lock pillar sealing strip.
3. Remove front guide lower two adjusting stud nuts and loosen upper two nuts (see Fig. 8-56).
4. Rotate rear edge of glass upward until regulator lift arm roller is free of sash channel cam and front two glass rollers are out of front guide channels (see Fig. 8-56). Remove glass inboard of side rail.

NOTE: If additional clearance is needed, the side roof rail weatherstrip can be detached at quarter window area.

5. To install, reverse removal procedure. Figure 8-57 is an exploded view of the quarter window assembly and identifies the various components and their assembly sequence.

Adjustments—"X-37" Style

To perform any rear quarter window adjustments, it is necessary to remove the rear quarter trim assembly.

1. To adjust window "fore or aft", loosen front and rear guide adjusting stud nuts, position window and guides as required, and tighten nuts.
2. To adjust window "in or out" at belt line, loosen front guide upper adjusting stud nuts, adjust studs in or out as required, and tighten stud nuts.
3. To adjust top of window "in or out", loosen front guide lower adjusting stud nuts, adjust

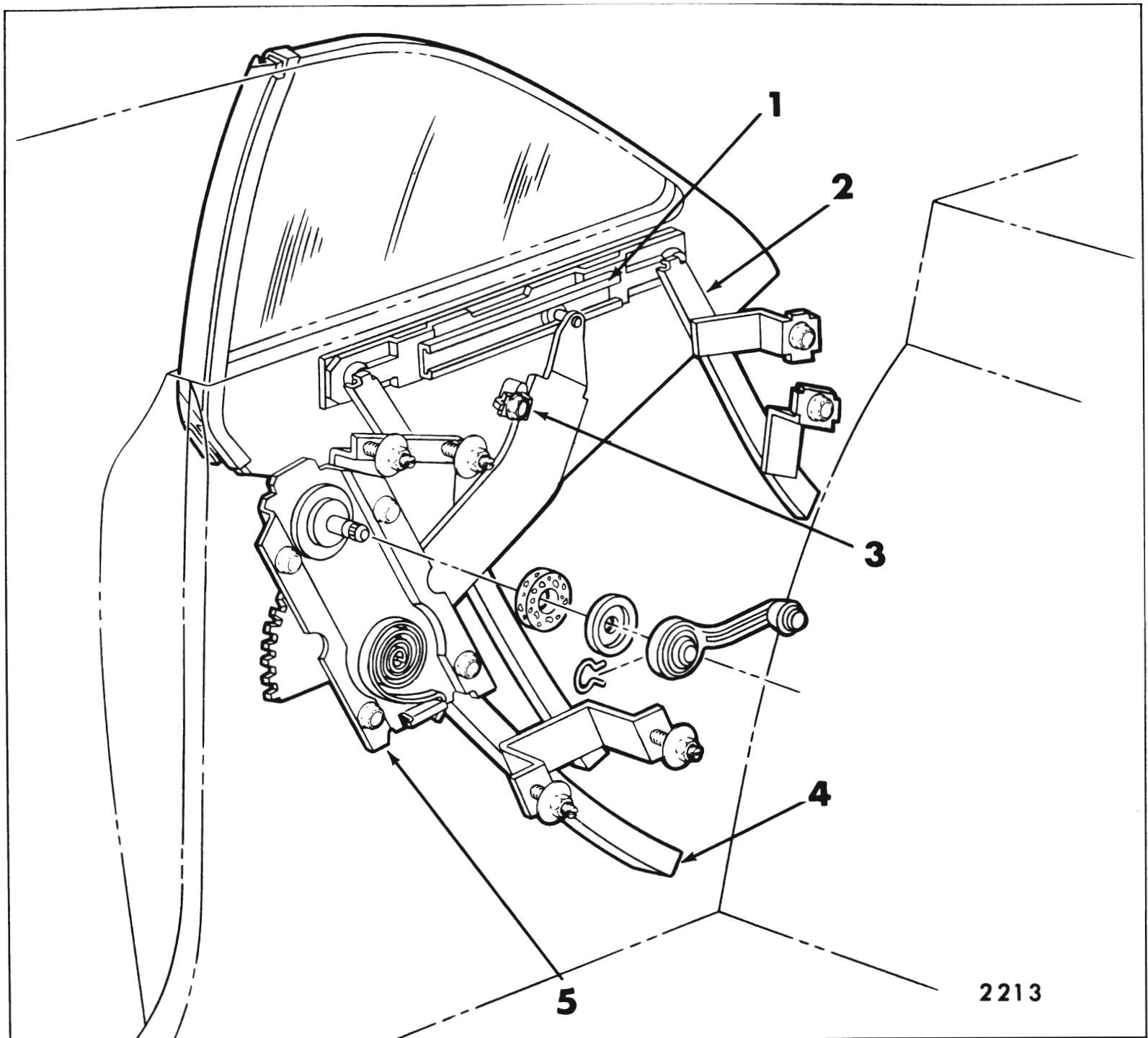

Fig. 8-36—Rear Quarter Hardware - "X-37" Styles

1. Sash Channel Cam
2. Rear Guide

3. Upper Stop
4. Front Guide

5. Window Regulator

studs in or out as required, and tighten stud nuts.

4. To relieve a "fore or aft" binding condition between front and rear guides, loosen front and rear guide adjusting stud nuts. Operate window to "full-up" position and tighten upper adjusting stud nuts. Operate window to "full-down" position and tighten remaining stud nuts.

NOTE: When adjusting studs on front guide, make certain that adjacent studs are adjusted

equally to prevent creation of a bind between cam channels.

5. To limit up-travel of window, adjust window stop as required (see Fig. 8-36).

g. Removal and Installation "Z-37" Styles

1. With window in full-up position, remove rear guide upper and lower attaching bolts (Fig. 8-58). Disengage guide from roller on window assembly and remove guide.

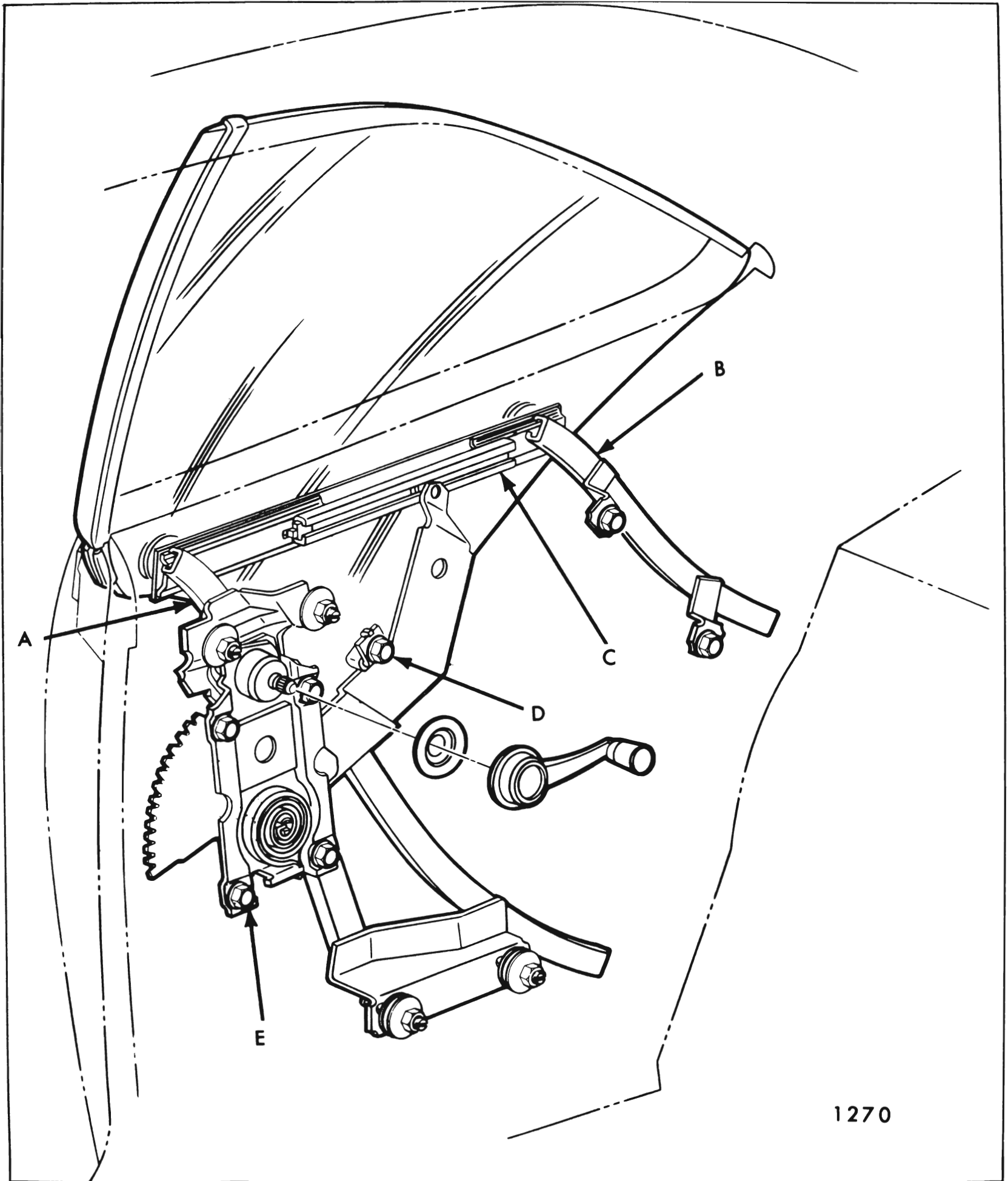

1270

Fig. 8-37—Rear Quarter Hardware - "37" Styles

A. Front Guide
B. Rear Guide

C. Lower Sash Channel Cam
D. Window Up-Stop

E. Window Regulator

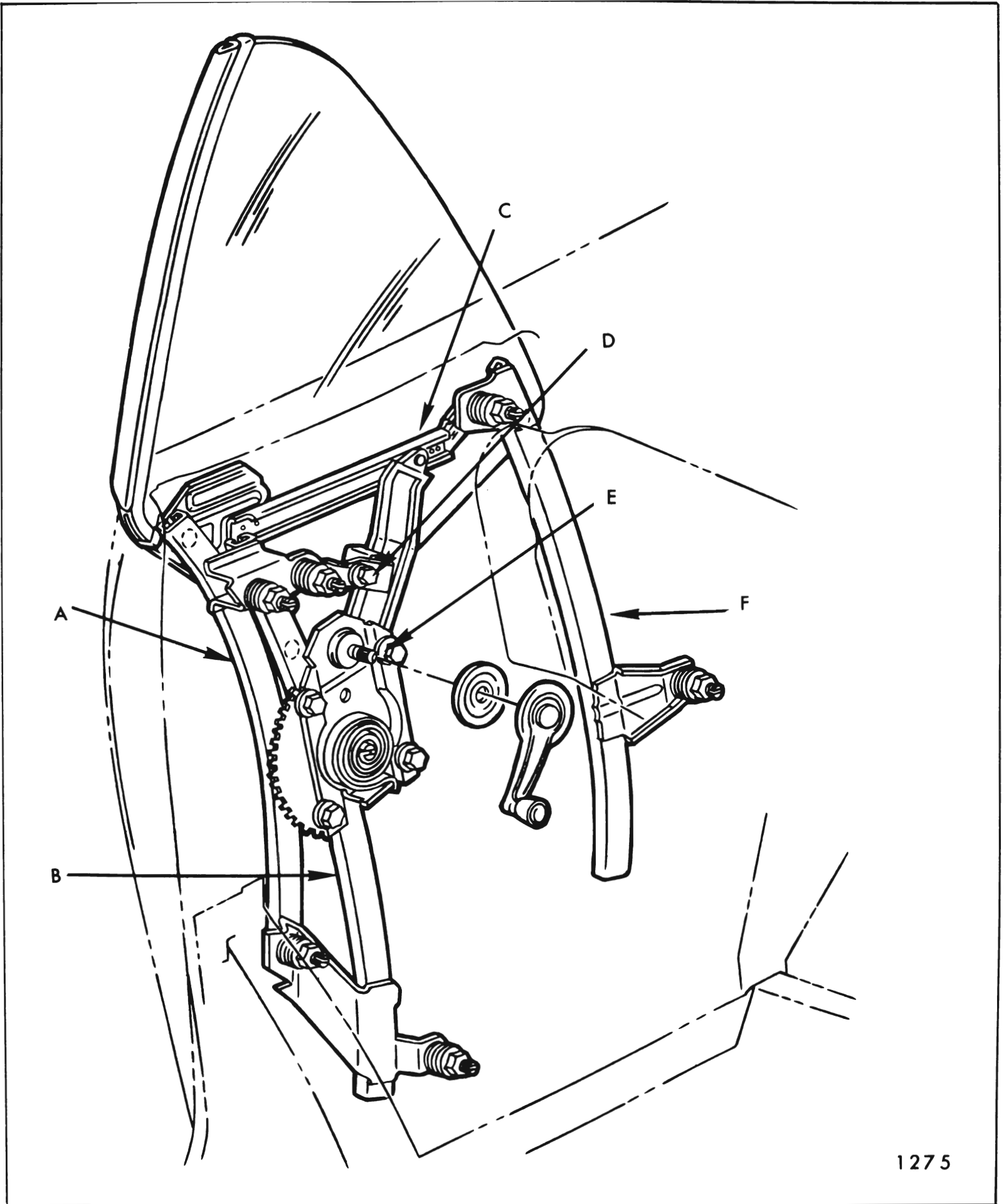

Fig. 8-38—Rear Quarter Hardware - "67" Style

A. Front Guide (Forward Channel)
B. Front Guide (Rearward Channel)

C. Sash Channel Cam
D. Window Up-Stop

E. Window Regulator
F. Rear Guide

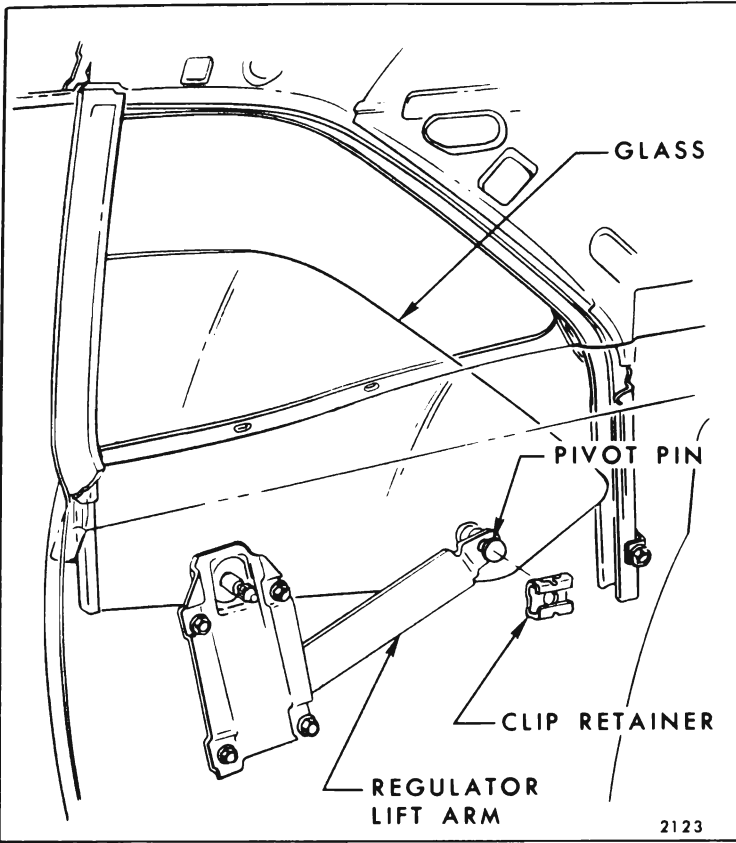

Fig. 8-39—Rear Quarter Window Attachment - "A-07" Styles

2. Remove regulator as described in a following procedure.

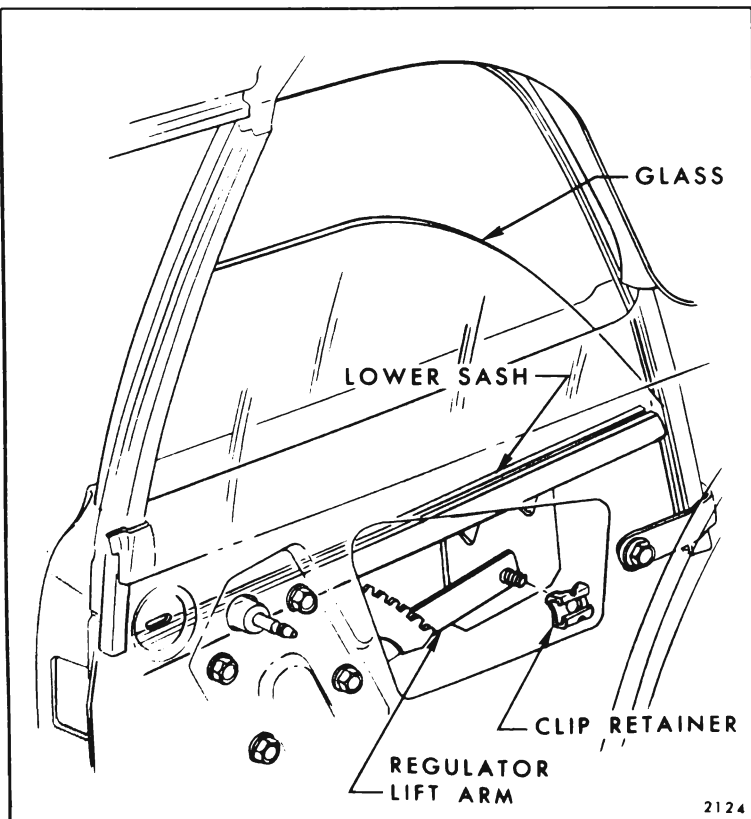

Fig. 8-40—Rear Quarter Window Attachment - "A-11" Styles

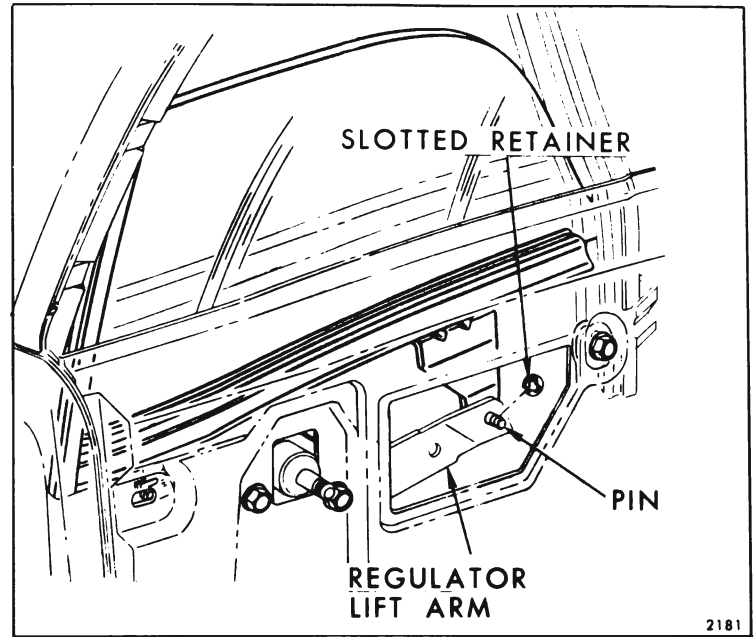

Fig. 8-41—Rear Quarter Window Attachment - "B-11" Styles

3. Slide rear quarter window upward and forward and pivot top rear corner of glass to a point outboard of side roof rail. Continue glass upward and forward to disengage front glass rollers from front guide assembly and remove rear quarter window from body.

4. To install, reverse removal procedure. Figure 8-59 is an exploded view of the quarter window assembly and identifies the various components and their assembly sequence.

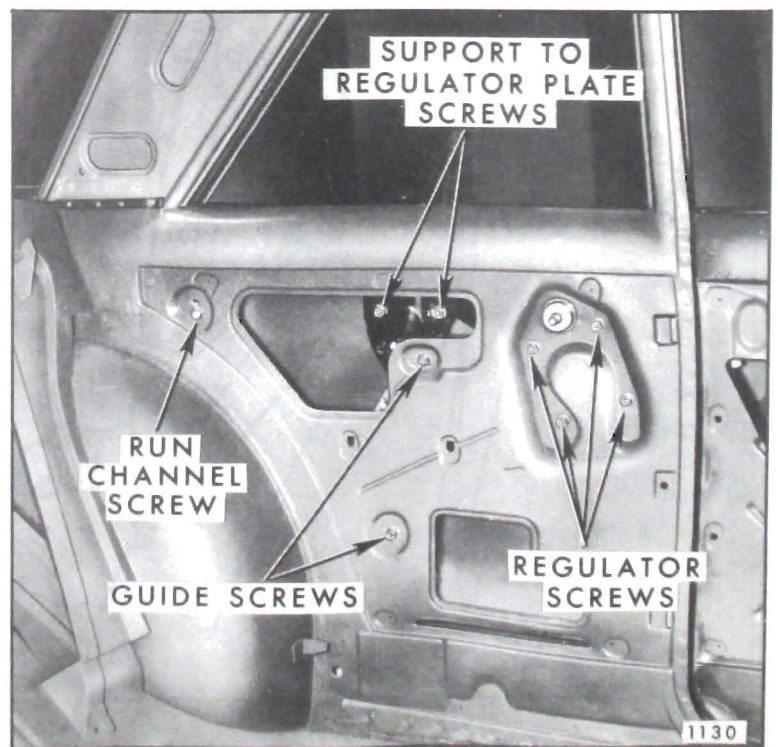

Fig. 8-42—Rear Quarter Hardware Attachment - "X-11" Style

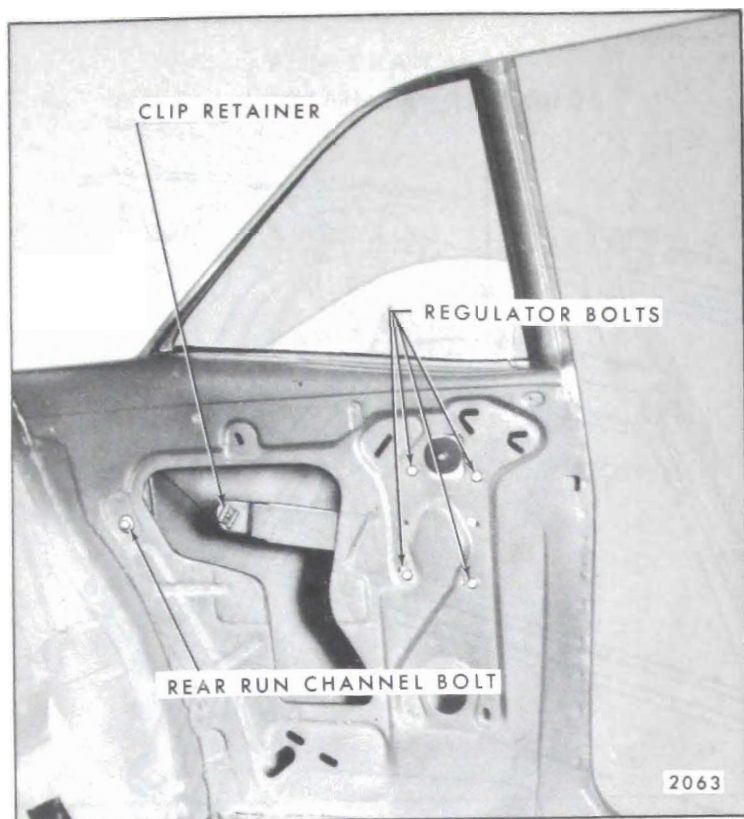

Fig. 8-43—Rear Quarter Hardware Attachment - "A-07" Styles Shown - "11" Styles Similar

Adjustments—"Z-37" Styles

1. The quarter window up-stop can be utilized for adjustments of glass to side roof rail weatherstrip (see Section "A-A" in Fig. 8-60).
2. The rear guide can be adjusted to gain proper fore and aft contact of rear quarter window vertical weatherstrip to rear edge of front door window (see section "C-C and F-F" in Fig. 8-60).
3. The upper two adjusting studs of the rear quarter window front guide are used for in or out and fore or aft adjustment of quarter window at front leading edge (see section "D-D" in Fig. 8-60).
4. The lower two adjusting studs of rear quarter window front guide are adjustable up or down and fore or aft for proper operation of quarter window (see section "E-E" in Fig. 8-60).

h. Removal and Installation "Z-67" Styles

1. Lower folding top.
2. Remove window regulator as described in a following procedure.
3. Raise glass straight up and remove from body.
4. To install, first engage lower forward roller

of glass into rear channel of front guide and then upper forward roller of glass into front channel of front guide and reverse removal procedure (see Fig. 8-38). Figure 8-61 is an exploded view of the quarter window assembly and identifies the various components and their assembly sequence.

Adjustments—"Z-67" Styles

1. The quarter window up-stop can be utilized for adjustments of glass to side roof rail weatherstrip (see section "A-A" in Fig. 8-62).
2. Both front and rear guides provide fore or aft and in or out adjustment at all attaching locations. The upper attaching locations directly affect position of quarter glass and lower attachments provide smooth operation of dropping rear quarter window (see Fig. 8-62).

REAR QUARTER WINDOW REGULATOR ASSEMBLY (MANUAL)—"B-C 37-47-57 AND 67" STYLES

Removal and Installation

1. Remove rear quarter trim assembly. On "67" styles remove inner panel access hole cover. On "37-47 and 57" styles, remove inner panel water deflector.
2. Operate window to "full-up" and prop it in that position.
3. Remove regulator attaching bolts (Fig. 8-48). Disengage regulator lift arm roller from window lower sash channel cam and remove regulator through inner panel access hole.
4. To install, reverse removal procedure.

REAR QUARTER WINDOW REGULATOR ASSEMBLY (ELECTRIC)—"B-C 37-47-57 AND 67" STYLES

Removal and Installation

1. Remove rear quarter trim assembly. On "67" styles remove inner panel access hole cover. On "37-47 and 57" styles, remove inner panel water deflector.
2. With window in almost fully lowered position, remove lower sash channel cam attaching screws and remove cam (Fig. 8-48). Manually raise window to full-up and prop in that position.

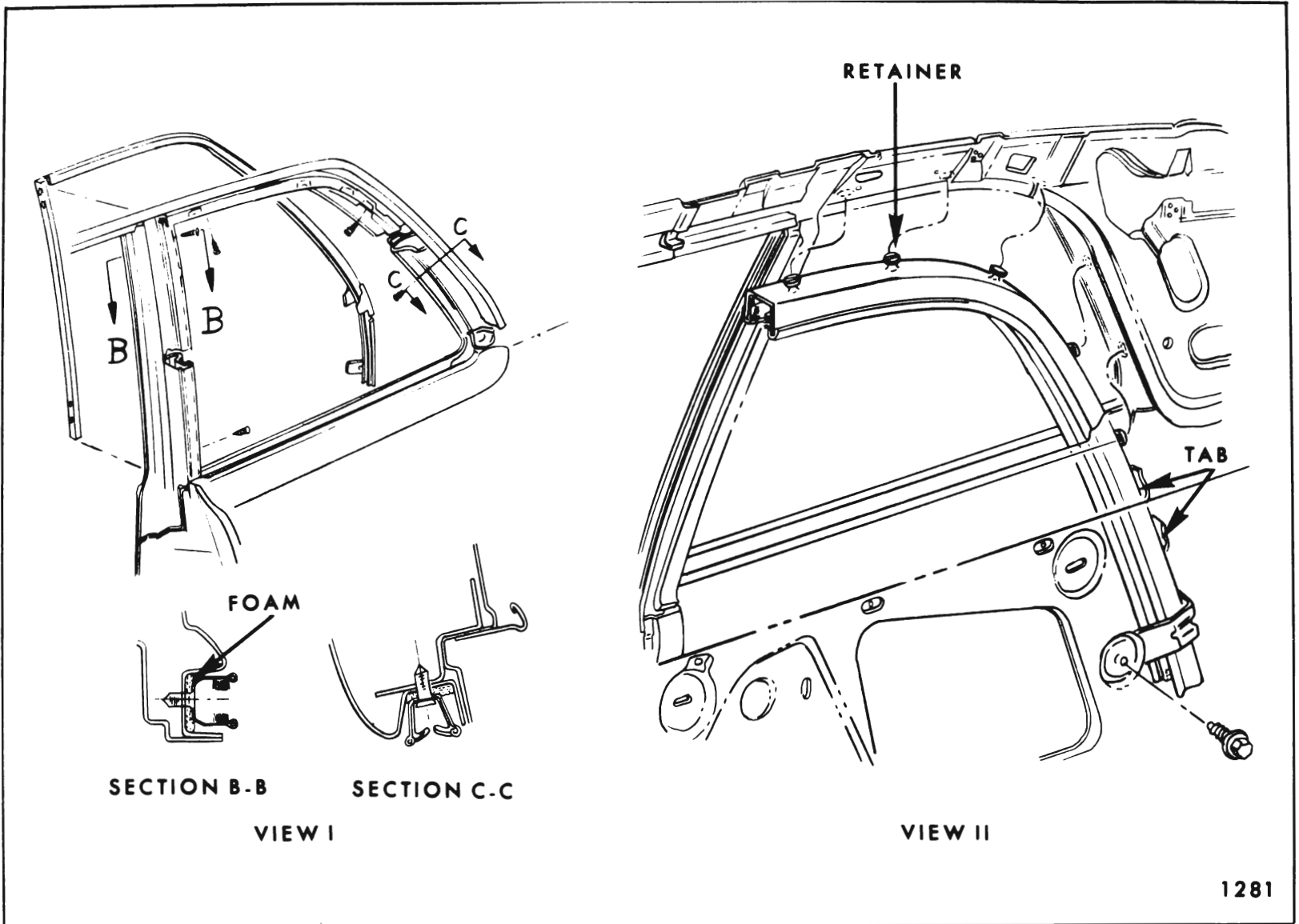

Fig. 8-44—Rear Quarter Window Glass Run Channels - Typical of All Closed Styles

3. On "67" styles, disconnect regulator motor wire harness at in-line connector located in-board of quarter inner panel. **DO NOT** attempt to disconnect permanent connector at regulator motor.
4. On the remaining styles, disconnect wire harness at motor. Remove window regulator attaching bolts (Fig. 8-48) and remove regulator through inner panel access hole.

NOTE: The procedure for removing electric motor from regulator is described and illustrated under "Door and Quarter Window Regulator Electric Motor Assembly" in the "Door" section of this manual.

5. To install, reverse removal procedure.

REAR QUARTER WINDOW REGULATOR ASSEMBLY (MANUAL OR ELECTRIC)—"A-E-X & Z" HARDTOP AND CONVERTIBLE STYLES

Removal and Installation

1. Remove rear quarter trim assembly and inner panel access hole cover (or water deflector).
2. On "E" styles, remove rear quarter window. On "A & X" styles and "Z-37" styles, prop window in a full-up position. On "Z-67" styles, lower rear quarter window to the position illustrated in Figure 8-63.
3. On "Z-37" styles, remove rear quarter window rear guide assembly.
4. On "A & E" styles, equipped with electric

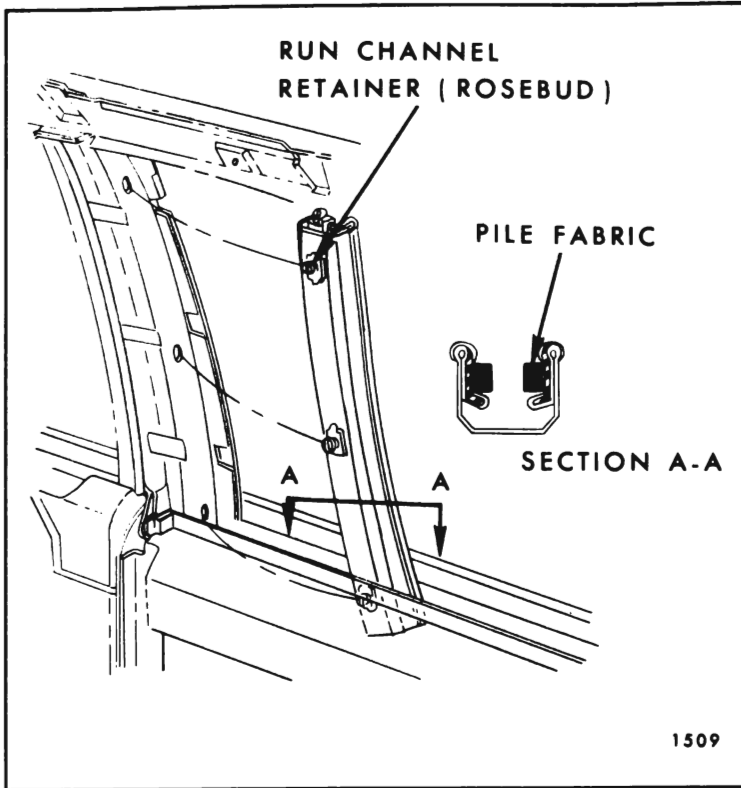

Fig. 8-45—Rear Quarter Window Front Glass Run Channels - Typical of "B" Styles

option, disconnect regulator motor wire harness at "in-line" connector and remove wire retaining clip attaching screw.

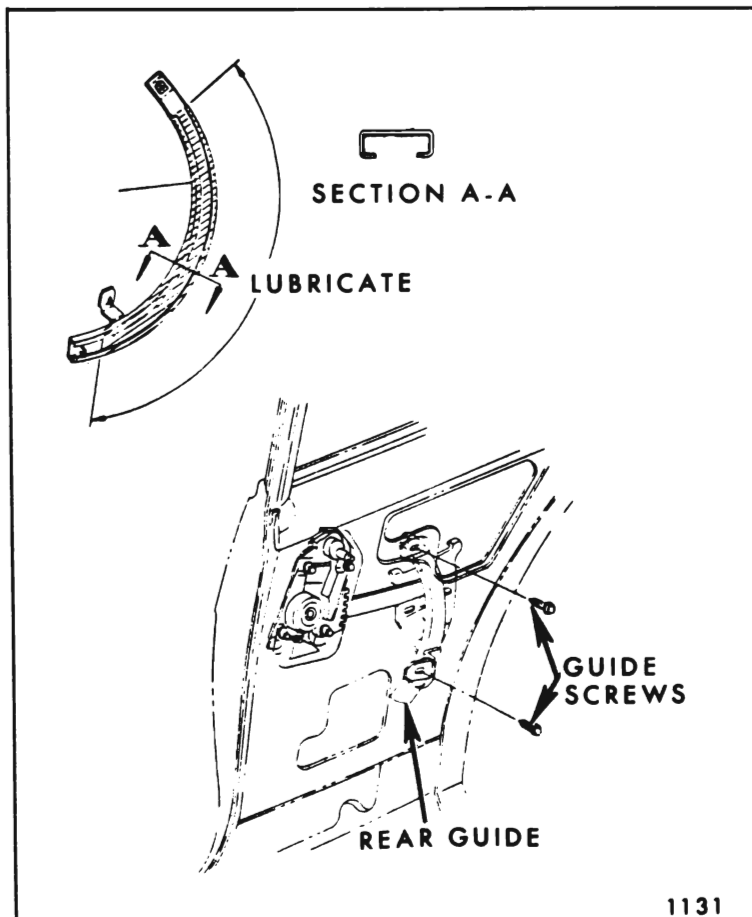

Fig. 8-46—Rear Quarter Window Guide - "X-11" Styles

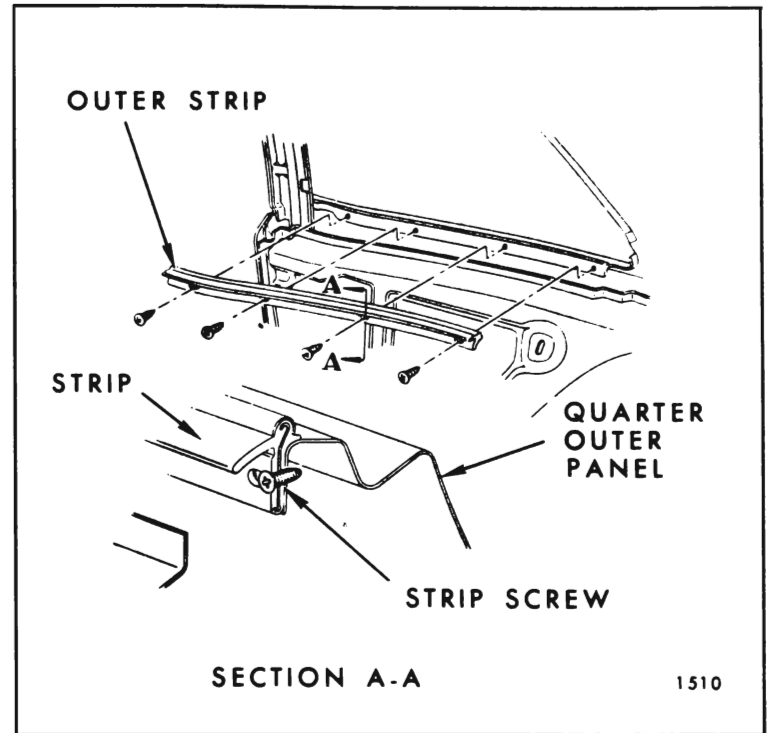

Fig. 8-47—Rear Quarter Window Outer Strip Assembly - All Closed Styles

5. Remove regulator attaching bolts (four on manual and five on electric, see Fig. 8-32). Slide unit rearward to disengage lift arm roller from sash cam and remove regulator.

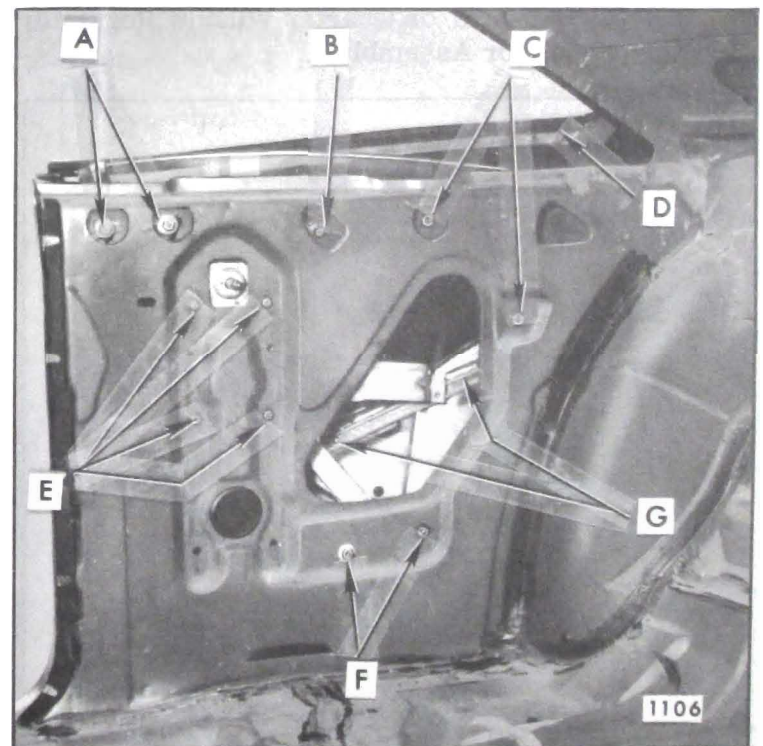

Fig. 8-48—Rear Quarter Hardware - "B and C" Hardtop Styles

- | | |
|---|---|
| A. Front Guide Upper Adjusting Studs and Nuts | E. Regulator Bolts |
| B. Up-Stop Bolt | F. Front Guide Lower Adjusting Studs and Nuts |
| C. Rear Guide Studs and Nuts | G. Sash Channel Cam Screws |
| D. Outer Strip Assembly | |

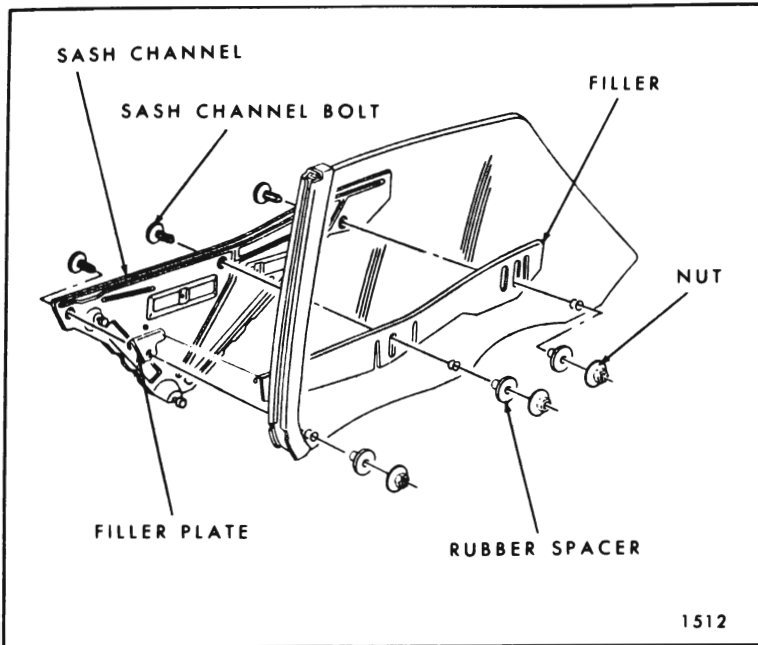

Fig. 8-49—Rear Quarter Window Assembly - "B&C" - "37-57 and 67" Styles

NOTE: If necessary, loosen upper attaching points of front guide to gain additional clearance.

6. To install, reverse removal procedure.

NOTE: The procedure for removing the electric motor from the regulator is described under "Door and/or Quarter Window Regulator Electric Motor Assembly".

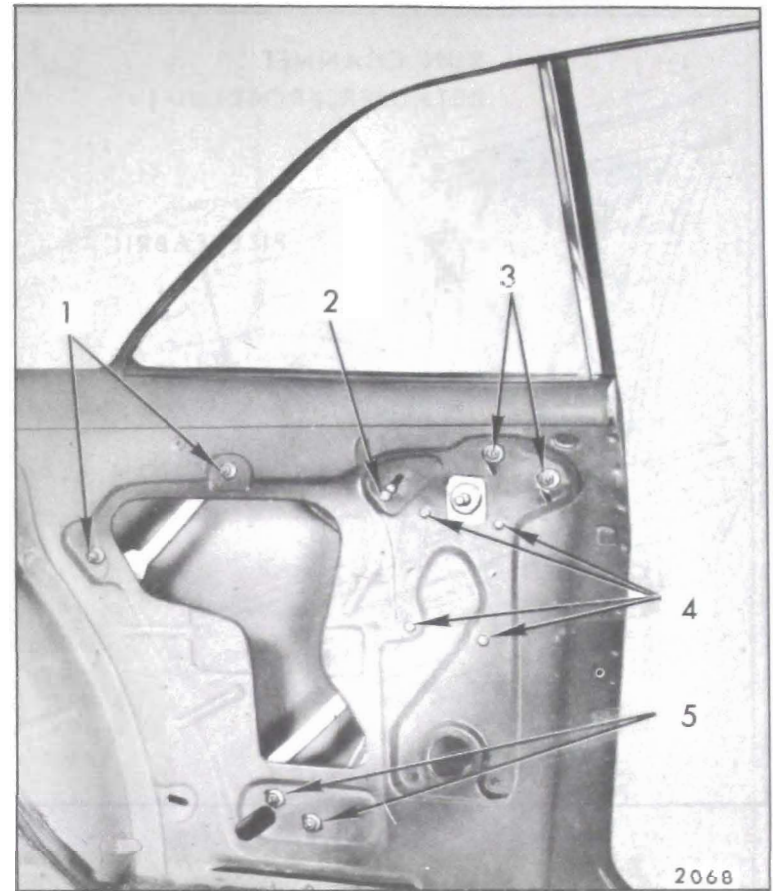

Fig. 8-51—Rear Quarter Hardware - "A-17" Style

- | | |
|---|---|
| 1. Rear Guide Adjusting Studs and Nuts | 4. Regulator Bolts |
| 2. Up-Stop Bolt | 5. Front Guide Lower Adjusting Studs & Nuts |
| 3. Front Guide Upper Adjusting Studs & Nuts | |

REAR QUARTER WINDOW FRONT GUIDE "B-C 37-47-57 AND 67" STYLES

Removal and Installation

1. Remove rear quarter window assembly as previously described.
2. Remove front guide upper and lower adjusting stud nuts (Fig. 8-48) and remove guide through access hole.
3. To install, reverse removal procedure.

REAR QUARTER WINDOW REAR GUIDE—"B-C 37-47-57 AND 67" STYLES

Removal and Installation

1. Remove rear quarter trim assembly. On "67" styles remove inner panel access hole cover. On "37-47 and 57" styles remove inner panel water deflector.
2. With window in full-up position, remove rear

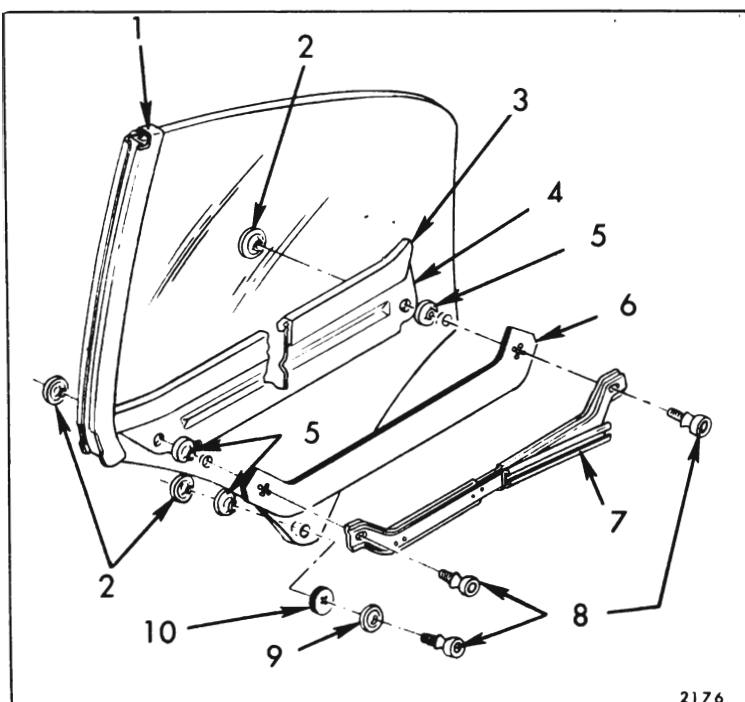

Fig. 8-50—Rear Quarter Window Assembly - Chevrolet "B-47" Style

- | | |
|----------------------------|----------------------------|
| 1. Front Sash Channel | 6. Lower Sash Inner Filler |
| 2. Nut | 7. Lower Sash Cam Assembly |
| 3. Lower Sash Outer Filler | 8. Roller Assembly |
| 4. Outer Filler Retainer | 9. Washer (Steel) |
| 5. Bushing | 10. Washer (Rubber) |

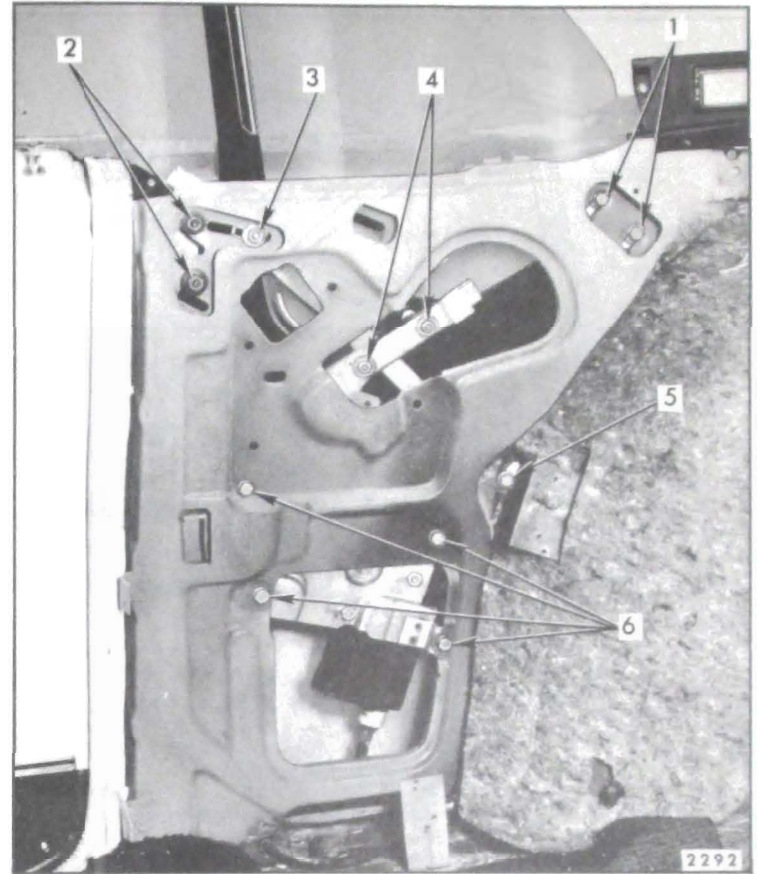
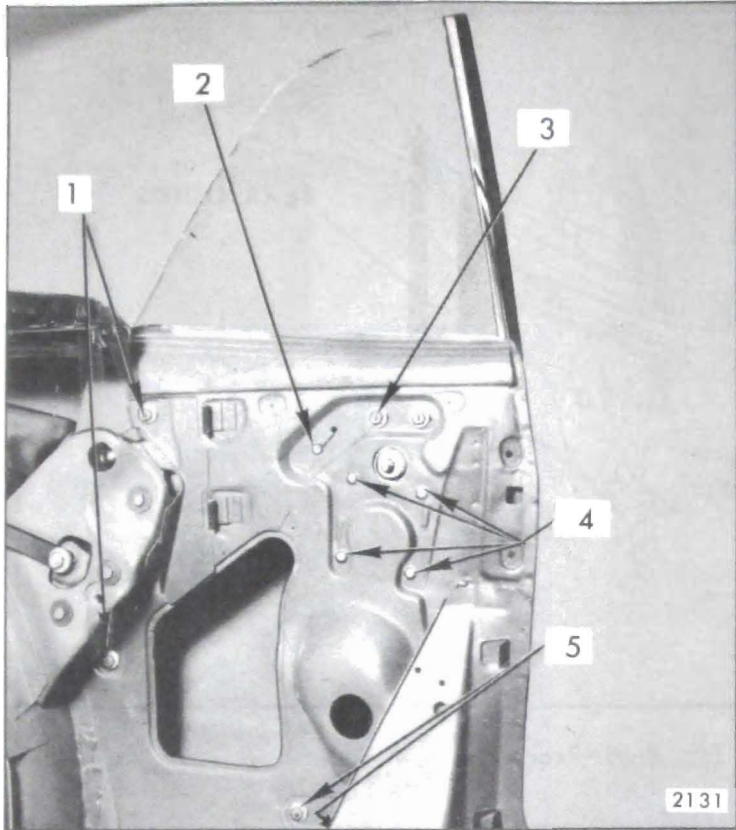

Fig. 8-52—Rear Quarter Hardware - "A-67" Style

Fig. 8-54—Rear Quarter Hardware - "E" Body

- | | |
|---|---|
| 1. Rear Guide Adjusting Studs and Nuts | 4. Regulator Bolts |
| 2. Up-Stop Bolt | 5. Front Guide Lower Adjusting Studs & Nuts |
| 3. Front Guide Upper Adjusting Studs & Nuts | |

- | | |
|---|---|
| 1. Rear Guide Attaching Bolts | 4. Regulator Lift Arm Cam Attaching Nuts |
| 2. Front Guide Upper Adjusting Studs & Nuts | 5. Front Guide Lower Attaching Bolt |
| 3. Up-Stop Attaching Bolts | 6. Regulator Attaching Bolts (4 for Elect., 5 for Manual) |

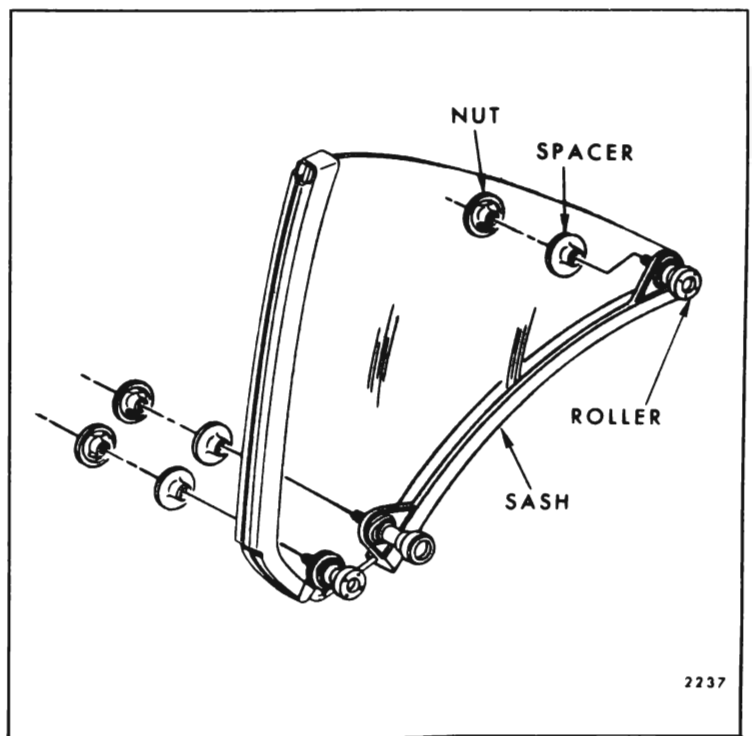
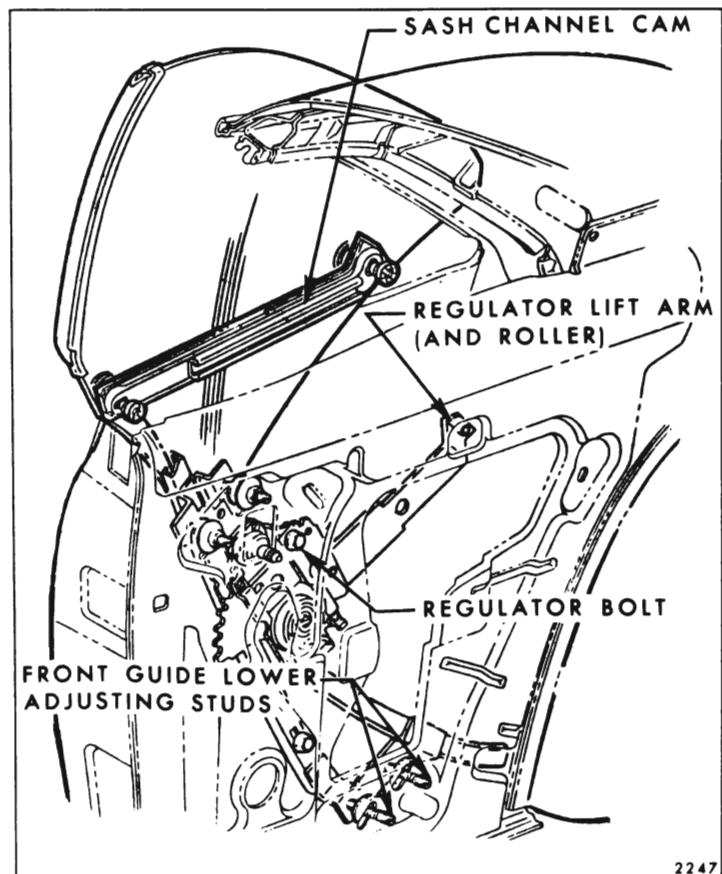

Fig. 8-53—Rear Quarter Window Removal "A-17 and 67" Styles

Fig. 8-55—Rear Quarter Window Assembly - "E" Body Styles

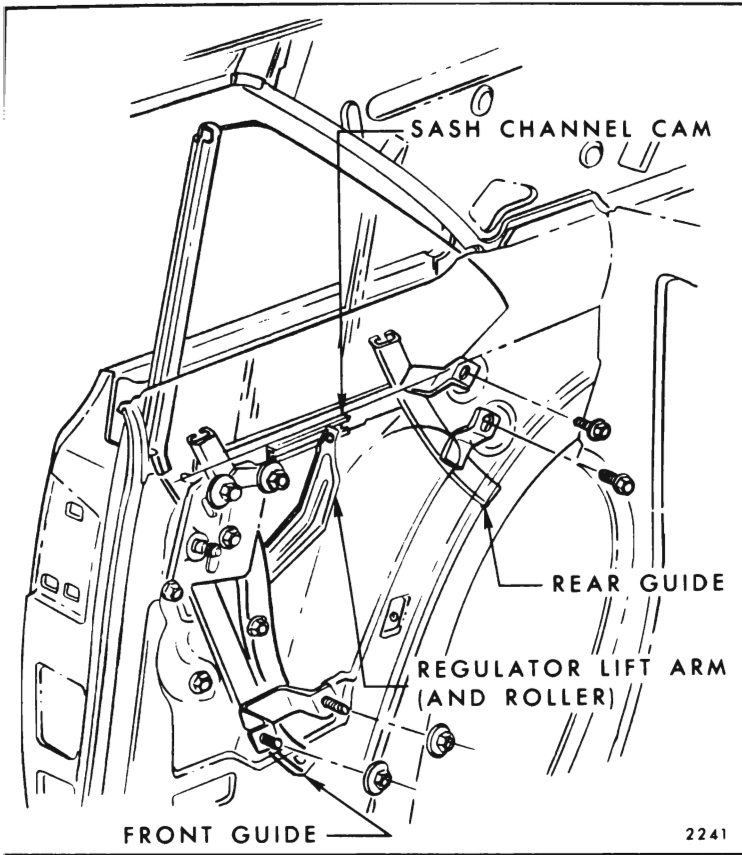

Fig. 8-56—Rear Quarter Hardware - "X"-37 Style

guide upper and lower adjusting stud nuts (Fig. 8-48). Disengage guide from roller on window lower sash channel and remove guide through access hole.

3. To install, reverse removal procedure.

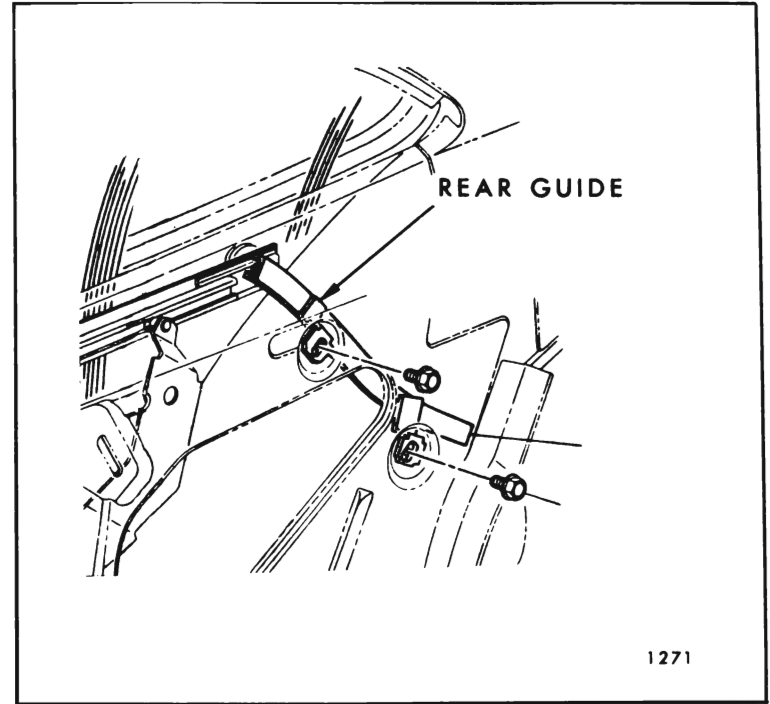

Fig. 8-58—Rear Quarter Window Rear Guide Assembly - "Z-37" Styles

REAR QUARTER WINDOW FRONT GUIDE ASSEMBLY—"A-E-X & Z" HARDTOP AND CONVERTIBLE STYLES

Removal and Installation

1. Remove rear quarter window assembly.
2. On "A, X & Z" styles, remove front guide upper and lower adjusting stud nuts (refer to Figs. 8-52 and 8-51). These illustrations are for "A" bodies but are indicative of all styles).

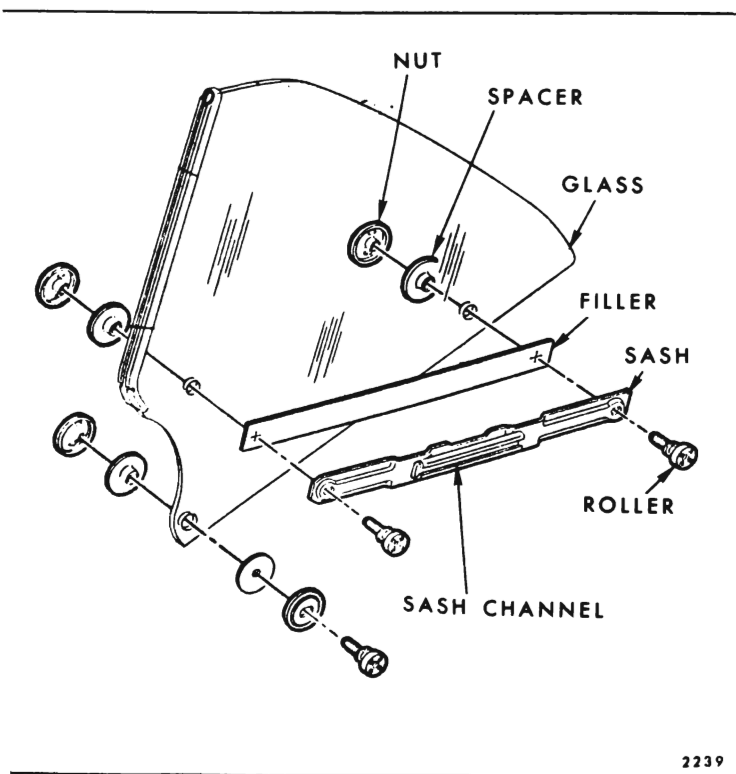

Fig. 8-57—Rear Quarter Window Assembly - "X-37" Style

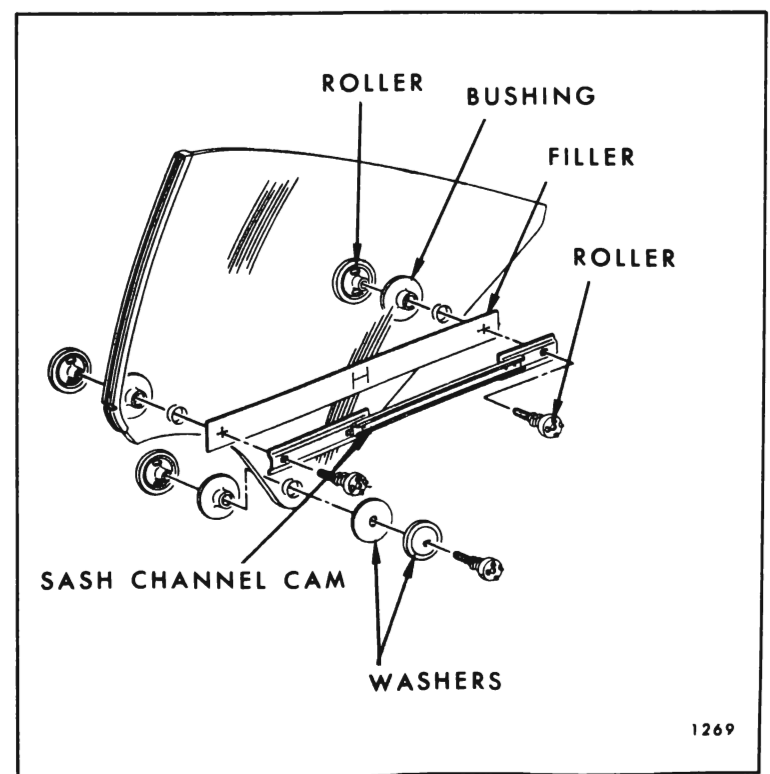

Fig. 8-59—Rear Quarter Window Assembly - "Z-37" Styles

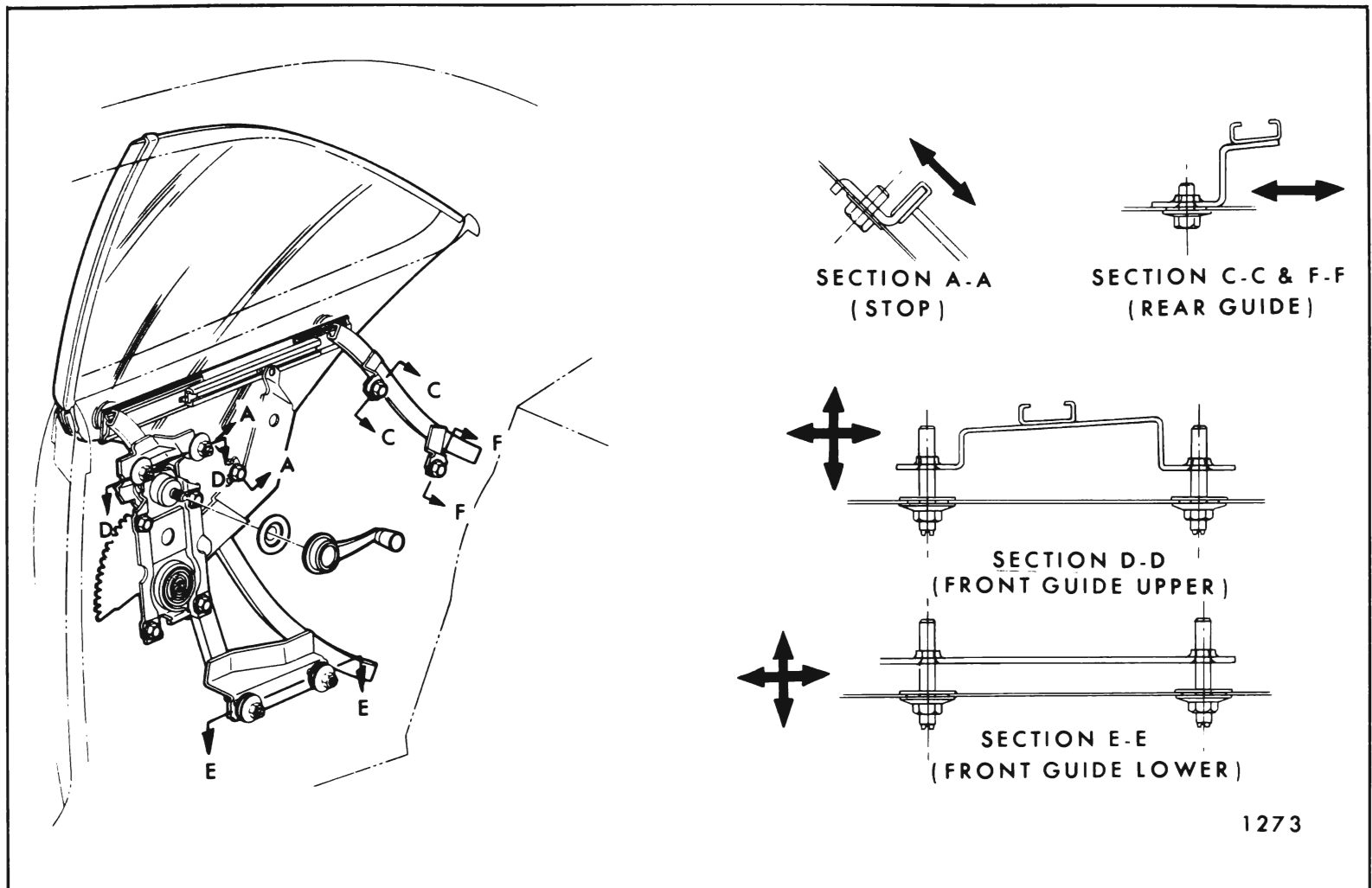

Fig. 8-60—Rear Quarter Window Adjustments - "Z-37" Styles (Arrows Indicate Adjustment Direction Available)

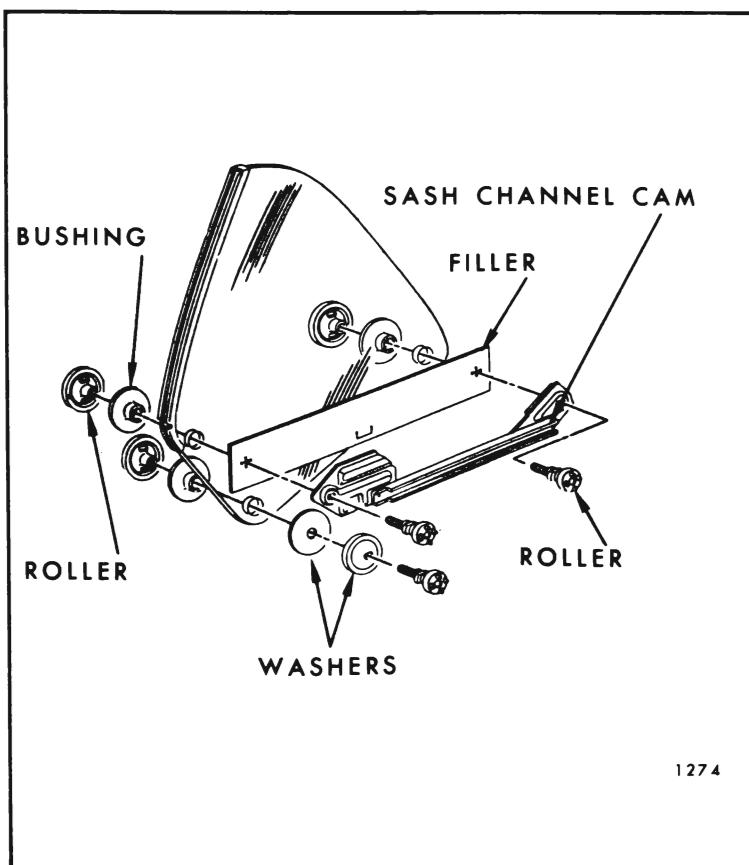

Fig. 8-61—Rear Quarter Window Assembly - "Z-67" Styles

NOTE: As explained under "Rear Quarter Window Assembly" - Removal and Installation for "E" bodies, the front guide attachments must be removed and guide lowered prior to removal of window assembly.

3. Disengage guide adjusting studs from slots in quarter inner panel and remove guide through access hole on all except "E" styles. On "E" bodies, remove front guide between rear quarter inner and outer panels at belt.
4. To install, reverse removal procedure. Adjust guide for proper window operation as specified under "Rear Quarter Window Adjustments".

NOTE: The rear channel of the front guide of "A-17 & 67" styles is equipped with an adjustable lower stop to control height of quarter window in the lowered position (see Fig. 8-32).

REAR QUARTER WINDOW GLASS RUN CHANNEL—CHEVROLET "B-47" STYLE

Removal and Installation

1. Remove rear quarter upper extension trim panel.

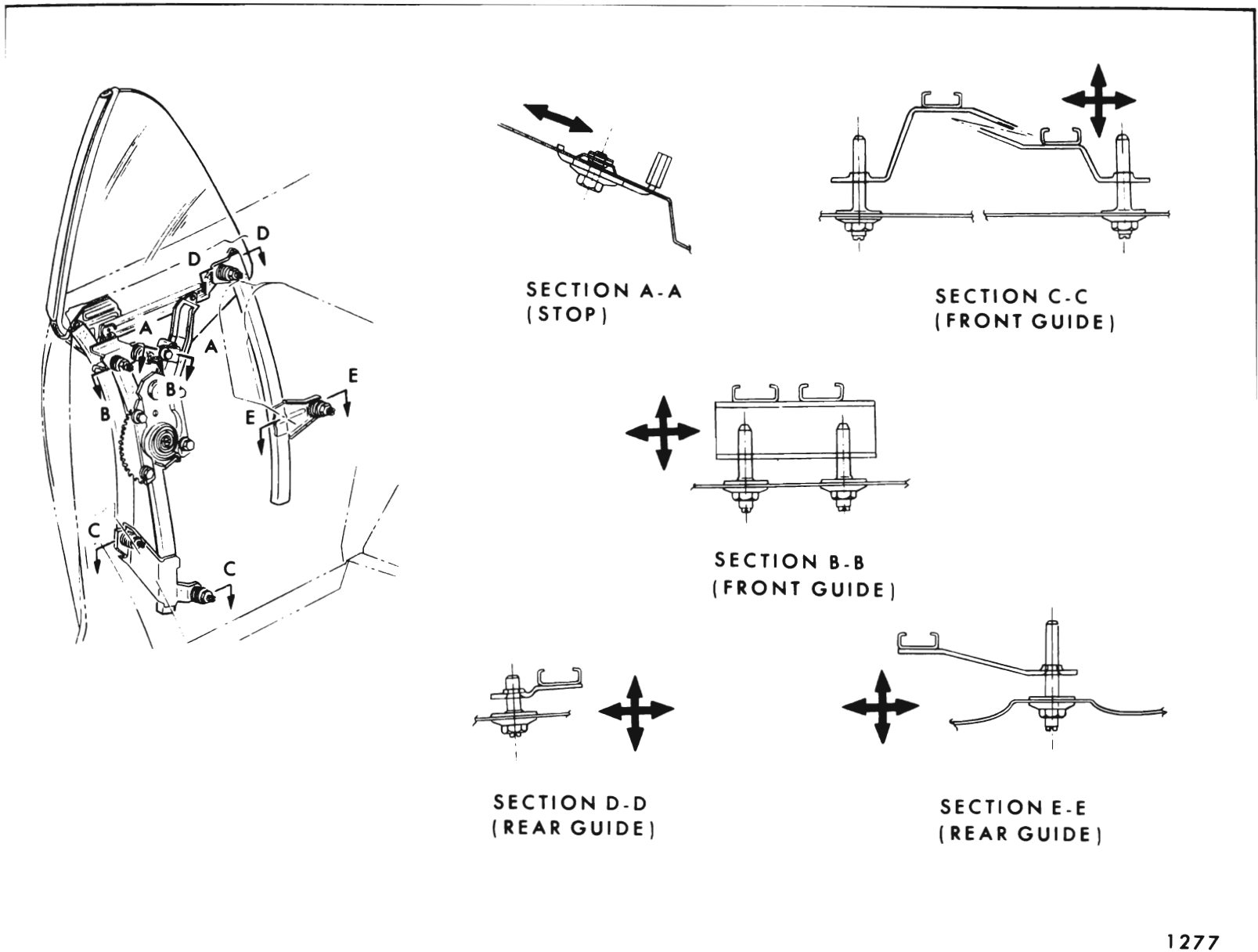

1277

Fig. 8-62—Rear Quarter Window Adjustments - "Z-67" Styles (Arrows Indicate Adjustment Direction Available)

2. With window in full-down position, remove screw securing run channel to rear quarter extension panel (Fig. 8-64).
3. Remove screw inserted through forward end of run channel into side roof rail (Fig. 8-64) and remove run channel from body.
4. To install, reverse removal procedure. Prior to installation apply a bead of body caulking compound to surface of run channel that mates with side roof rail to effect a weathertight seal when installed.
2. Remove screw securing side roof rail weatherstrip, weatherstrip retainer and rear quarter window run channel to side roof rail (see View "B" in Fig. 8-65).
3. Remove screw securing lower end of run channel to rear quarter inner panel (see View "B" in Fig. 8-65).
4. On Buick styles, remove screw securing outer wall of run channel to side rail (see Section "A-A" in Fig. 8-65).
5. Remove rear quarter window upper glass run channel.
6. To install, reverse removal procedure. If original sealing strip (see section "E-E" in Fig. 8-65) is damaged, seal run channel to side rail with pumpable caulking compound.

REAR QUARTER WINDOW UPPER GLASS RUN CHANNEL ASSEMBLY—"E" STYLES

Removal and Installation

1. Remove rear seat cushions and back (see seat trim index).

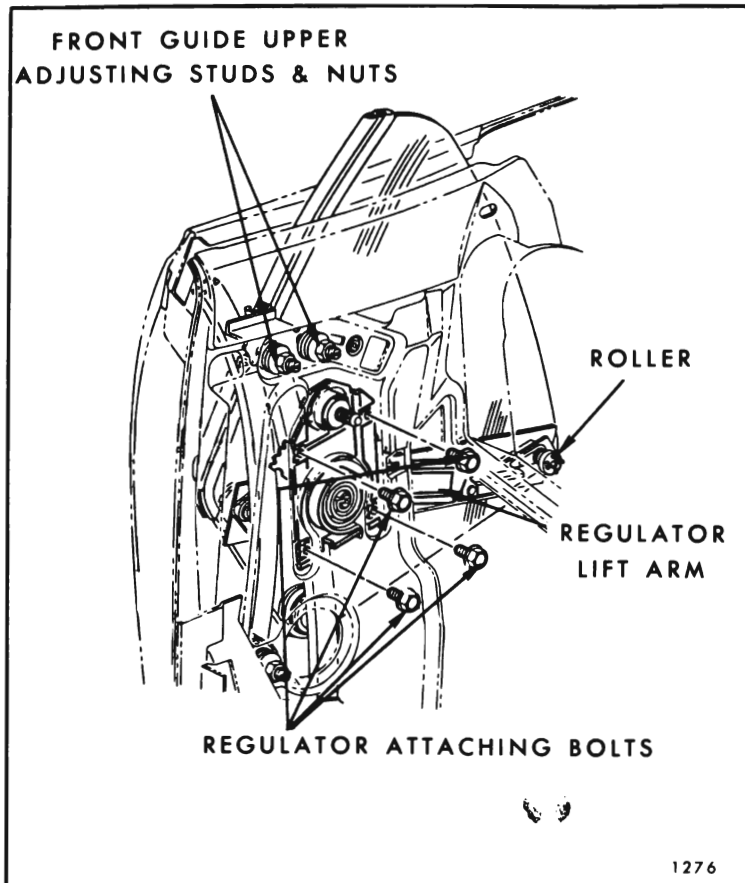

Fig. 8-63—Rear Quarter Window Regulator Attachment - "Z-67" Styles

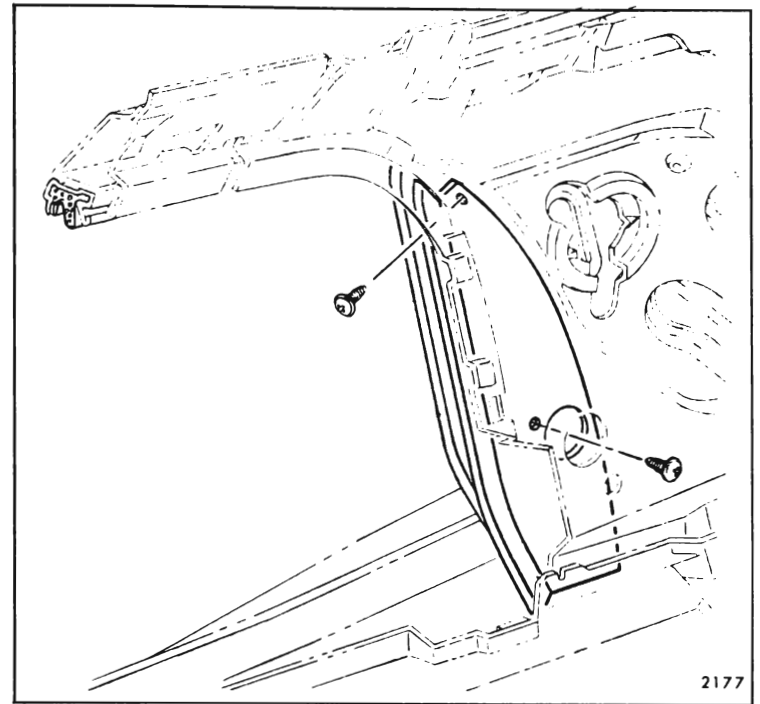

Fig. 8-64—Rear Quarter Window Glass Run Channel - "B-47" Style

REAR QUARTER WINDOW OUTER STRIP ASSEMBLY—PONTIAC, OLDSMOBILE, AND BUICK "B-37 AND 67" STYLES

Removal and Installation

1. Remove rear quarter trim assembly. On "67" styles remove inner panel access hole cover. On "37" styles remove inner panel water deflector.
2. Working through access hole, loosen down-stop attaching screw (Fig. 8-66). Slide stop to bottom of guide channel and retighten stop bolt.
3. Operate window to full-down position and remove screws securing outer strip assembly to outer panel return flange.
4. To install, reverse removal procedure. Reposition window down-stop for proper alignment of top edge of glass with body belt line when window is fully lowered.

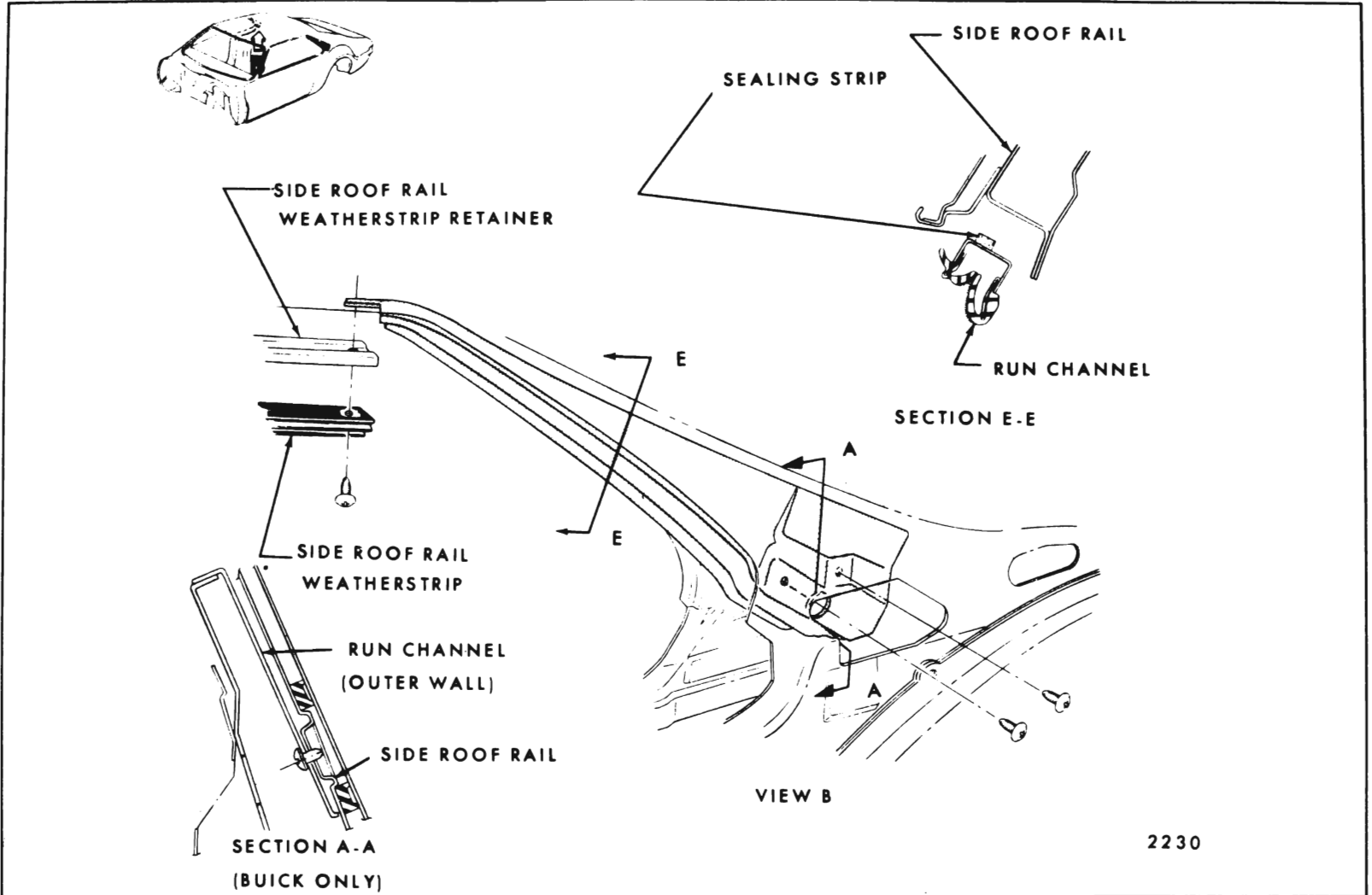

Fig. 8-65—Rear Quarter Window Upper Glass Run Channel - "E" Body Styles

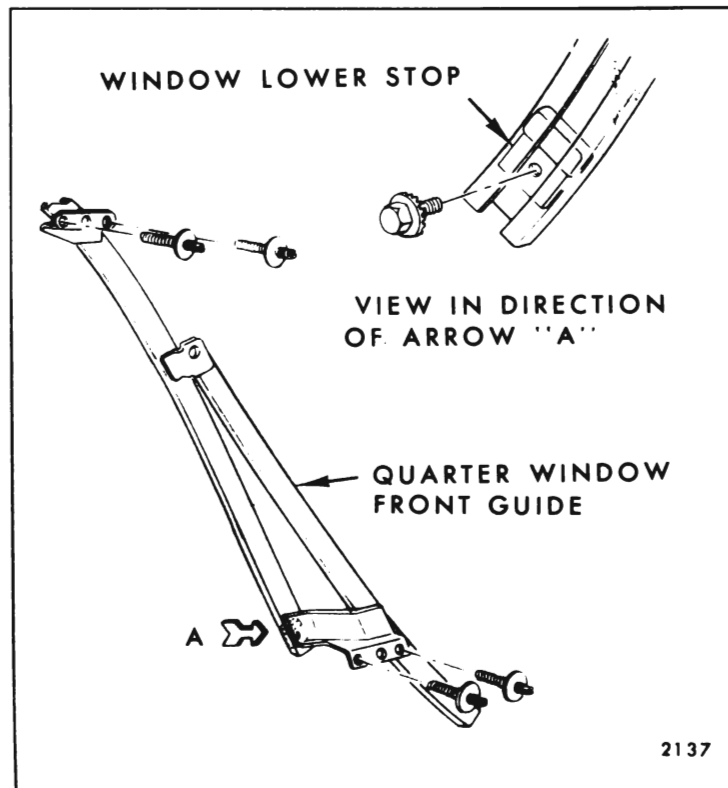

Fig. 8-66—Rear Quarter Window Lower Stop Adjustment - Styles so Equipped