

GROUP 1

MAINTENANCE

MAINTENANCE RECOMMENDATIONS

Maintenance and lubrication recommendations for the Gran Sport Option are the same as those previously published for 1965 Specials and Skylarks. Refer to Figure 1-1 for lubricant types, capacities, and maintenance points.

1965 BUICK SKYLARK GRAN SPORT

44427 - 44437 - 44467

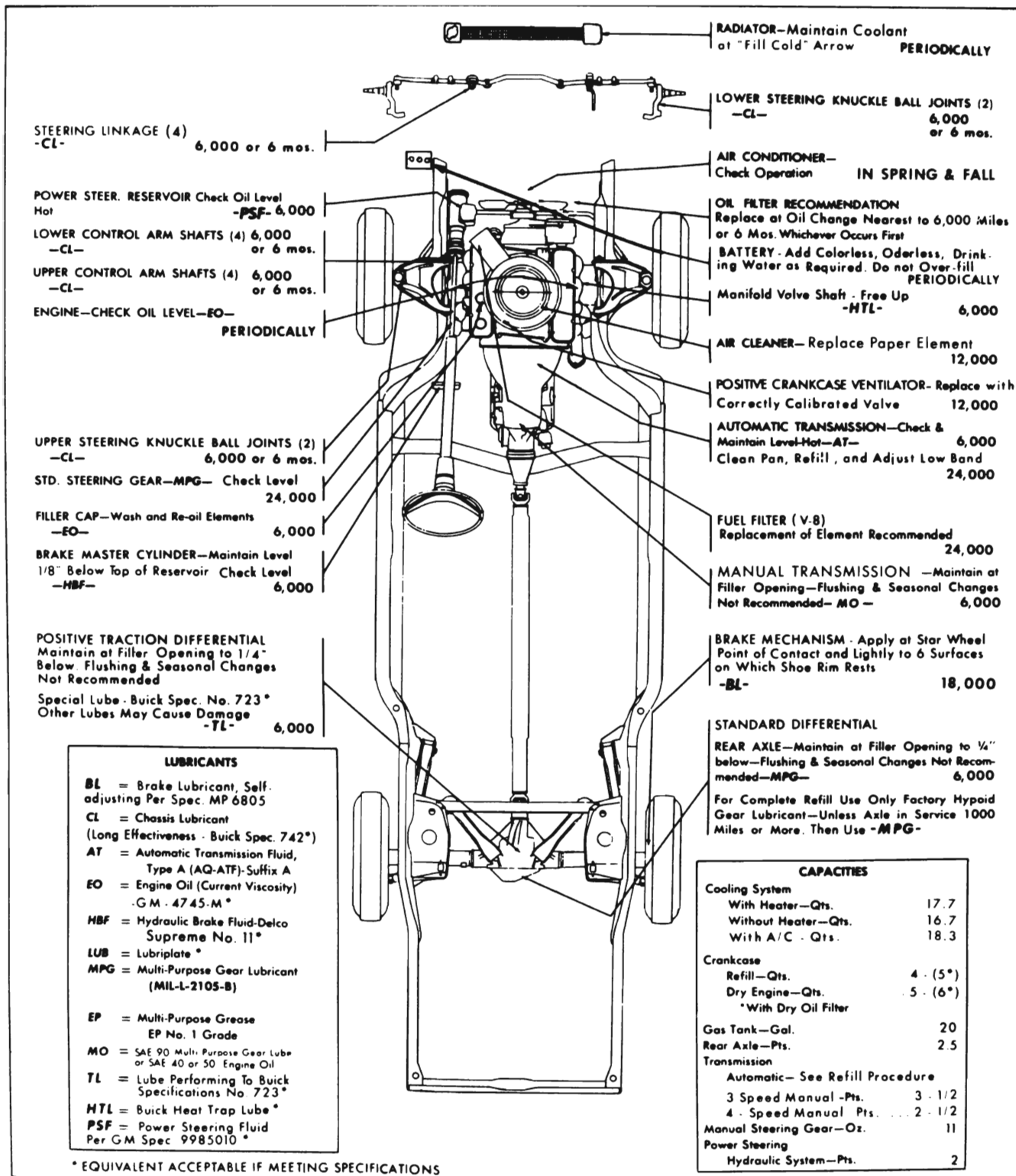

* EQUIVALENT ACCEPTABLE IF MEETING SPECIFICATIONS

Figure 1-1—1965 Skylark Gran Sport Lubrication Chart