

GROUP 9-D

DELCO MORAINE POWER BRAKES

CONTENTS IN SECTION 9-D

Paragraph	Subject	Page	Paragraph	Subject	Page
9-14	Description of Power Brake Unit . .	9-23	9-18	Cleaning, Inspection and Replacement of Parts	9-32
9-15	Power Brake Unit Trouble Diagnosis	9-28	9-19	Assembly of Power Brake Unit . . .	9-34
9-16	Removal of Power Brake Unit	9-29	9-20	Installation of Power Brake Unit . .	9-36
9-17	Disassembly of Power Brake Unit .	9-30	9-21	Testing of Power Brake Unit	9-37

9-14 DESCRIPTION OF POWER BRAKE MECHANISM

a. General Description of Power Brake Unit

The Delco Moraine Power Brake Unit is a combined vacuum and hydraulic unit which utilizes engine intake-manifold vacuum and atmospheric pressure to provide power-assisted application of vehicle brakes. The Unit takes the place of the master cylinder in a conventional brake system. From the master cylinder connection outward to the wheel units, there is no other change in the brake system. In addition to the master cylinder connections, the unit requires a vacuum connection to the engine intake-manifold (through a vacuum check valve) and a mechanical connection to the brake pedal. As shown in Figure 9-15, & 15a the unit is self-contained with no external rods or levers exposed to dirt or moisture.

The Power Brake Unit provides lighter pedal pressures. These lighter pedal pressures are obtained in combination with reduced pedal travel, making it possible to bring the brake pedal down to the approximate height of the accelerator pedal when at closed throttle position. Thus, the driver, after closing the throttle, can shift his toe from one pedal to the other without lifting his heel from the floor.

The vacuum check valve mounted on the power brake front housing permits several applications of the Power Brake Unit with vacuum-assist after the engine has stopped or after any other loss of vacuum. When the vacuum stored in the unit has been lost, or in case of vacuum failure at the unit or its vacuum connections, the brakes can be applied in the conventional manner. Since the vacuum assist is not available, the pedal force will be greater.

b. Construction of Power Brake Unit

The Unit is composed of two main sections: The vacuum power cylinder and the hydraulic master cylinder.

The vacuum power cylinder contains the power piston assembly which houses the control valve and reaction mechanism, and the power piston return spring. The control valve is composed of the air valve and the floating control valve assembly. The reaction mechanism consists of a hydraulic piston reaction plate and a series of levers. An air filter element is assembled around the push rod and fills the cavity inside the hub of the power piston. The push rod, which operates the air valve, projects out of the end of the power cylinder housing through a boot. A vacuum check valve assembly is mounted in the

front housing assembly for connection to the vacuum source.

A fluid reservoir is integrally cast with the master cylinder and supplies fluid to the space between the primary and secondary seals through a hole in the casting.

Connection is made to the wheel cylinder through the hydraulic outlet and a conventional check valve.

c. Operation of Power Brake Unit

(1) Released Position

A line from the engine intake manifold is connected to the vacuum check valve in the front housing of the power brake. This check valve prevents loss of vacuum when manifold vacuum falls below that in the power brake system.

At the released position the air valve is seated on the floating control valve. See Figure 9-16. The air under atmospheric pressure, which enters through the filter element in the tube extension of the power piston, is shut off at the air valve. The floating control valve is held away from the valve seat in the power piston. Vacuum, which is present at all times in the space to the left of the power piston, is free to evacuate any existing air on the right side of the power piston.

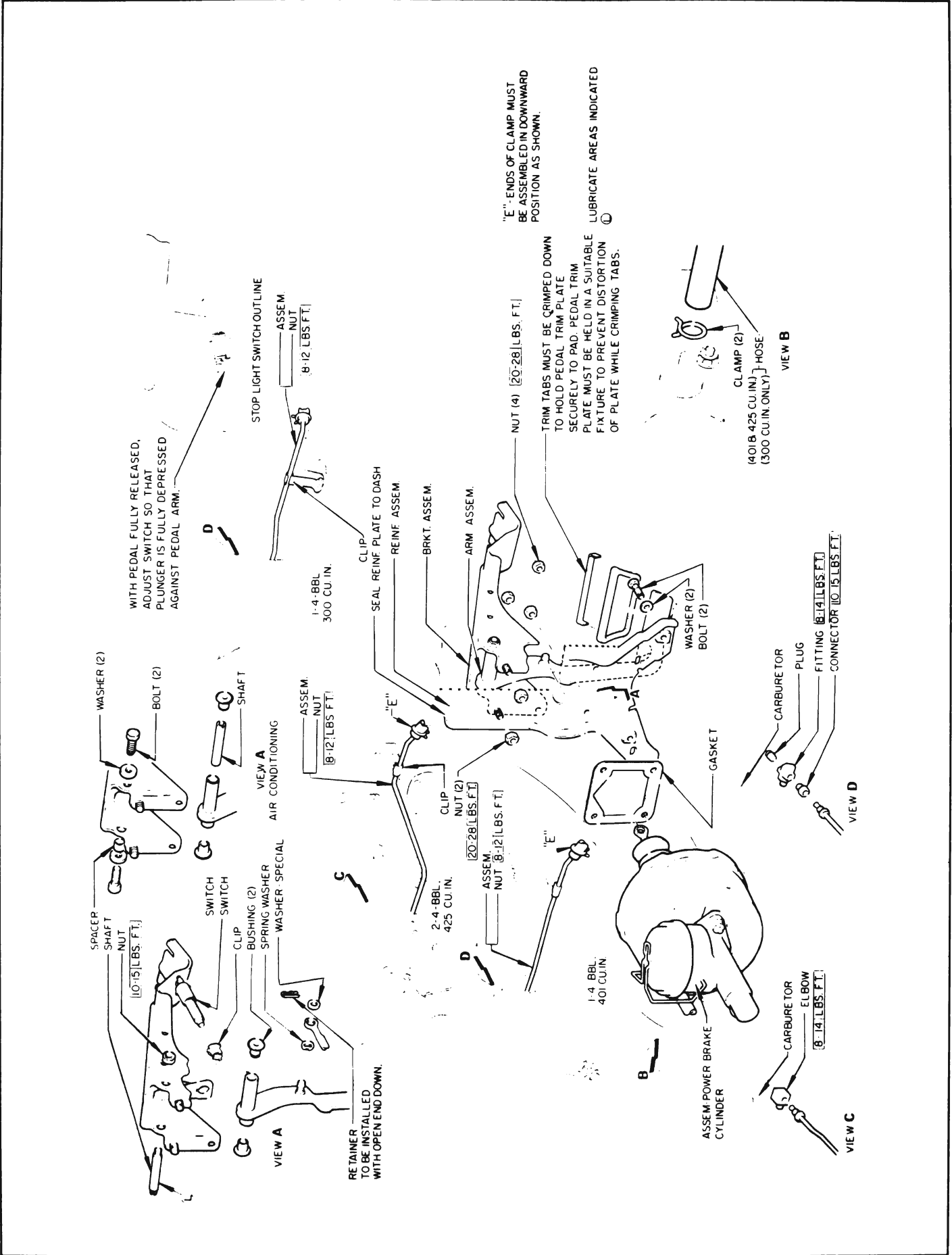

Figure 9-15—Power Brake Installation - 45, 46, 48000 Series

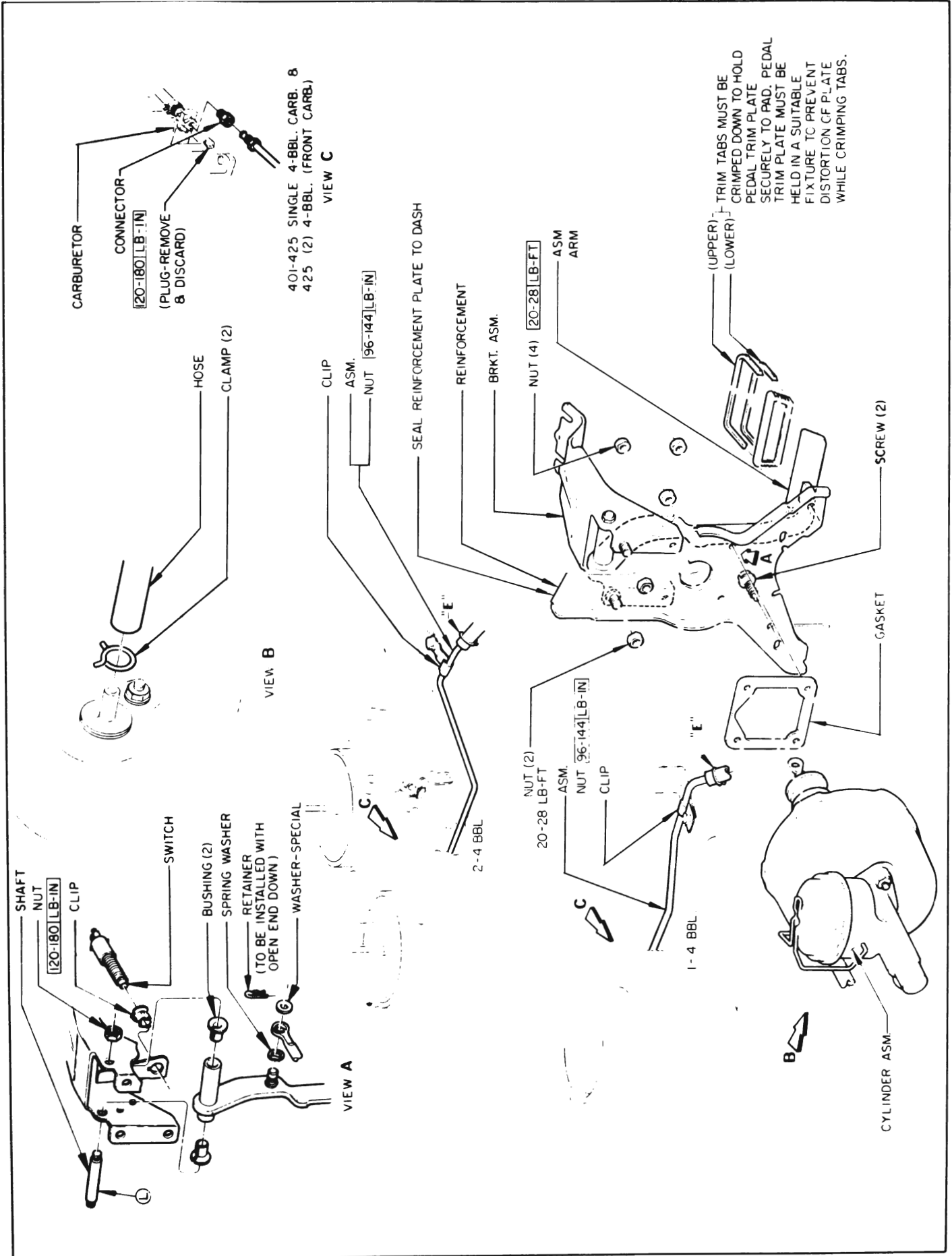

Figure 9-15a—Power Brake Installation - 49000 Series

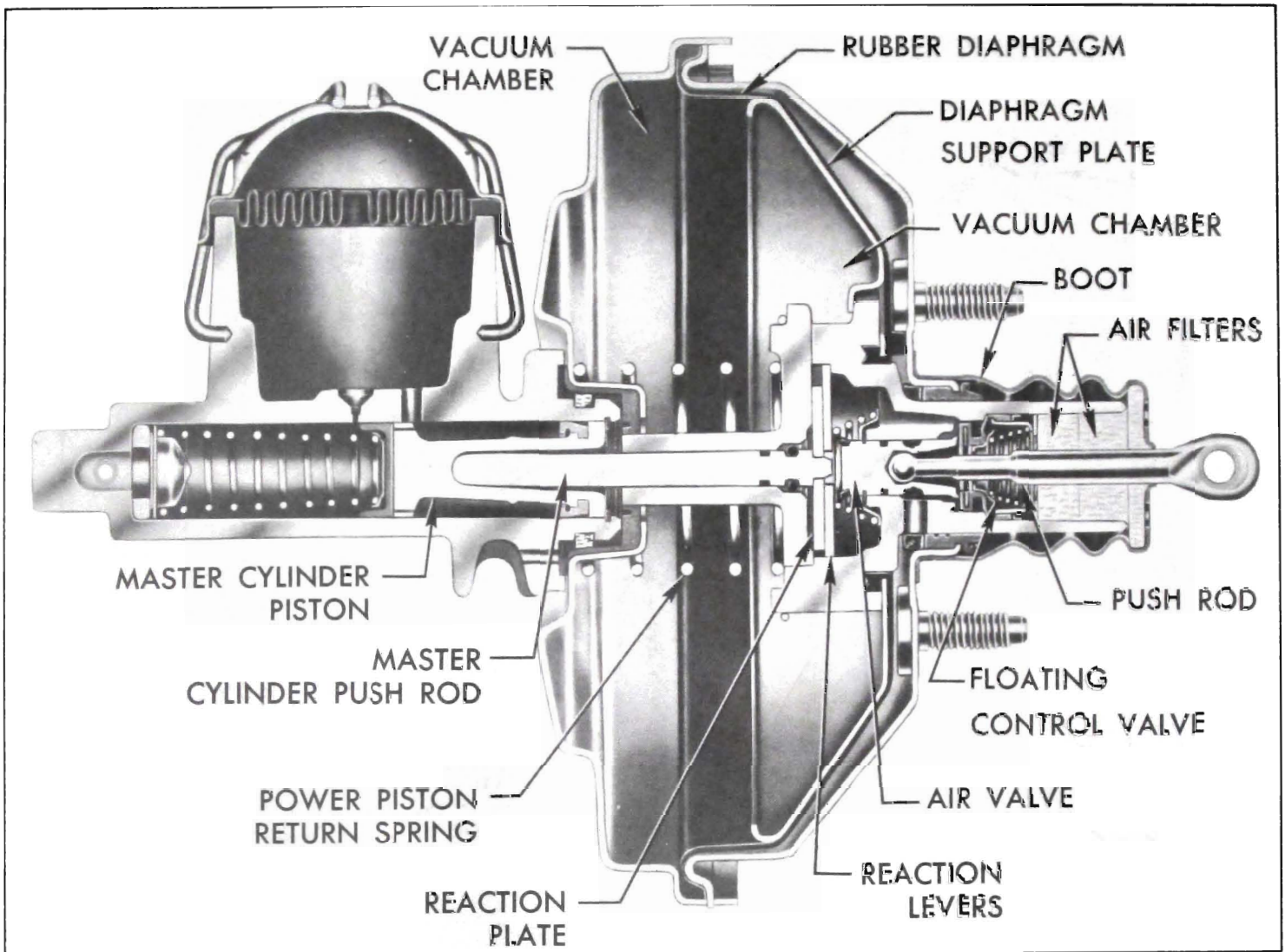

Figure 9-16—Power Brake Unit - Released Position

This air is drawn through two small passages in the power piston, over the valve seat in the power piston and then through the power piston into the space at the left of the power piston. It is then drawn through the check valve and thence to the vacuum source.

In this position there is vacuum on both sides of the power piston, and the power piston is held against the rear housing by the power piston return spring. At rest, the hydraulic reaction plate is held against the reaction retainer. The reaction levers are held back against the hydraulic reaction plate by the air valve spring. The air valve spring holds

the air valve back so that its retaining ring rests against the power piston.

The floating control valve assembly is held against the air valve seat by the floating control valve spring. In this position, the by-pass hole in the hydraulic master cylinder is open to the reservoir and fluid can flow freely in either direction between the hydraulic cylinder and the fluid reservoir.

A residual pressure is maintained in the brake lines by the check valve and its spring.

(2) Applying Position

As the pedal is depressed, the push rod carries the air valve

away from the floating control valve. See Figure 9-17. The floating control valve will follow until it is in contact with the raised seat in the power piston. When this occurs, the vacuum is shut off to the right hand side of the power piston, and air under atmospheric pressure rushes through the air filter and travels past the seat of the air valve and through two passageways into the housing on the right of the power piston.

Since there is still vacuum on the left side of the power piston, the force of the air at atmospheric pressure on the right of the piston will force the power piston to travel to the left.

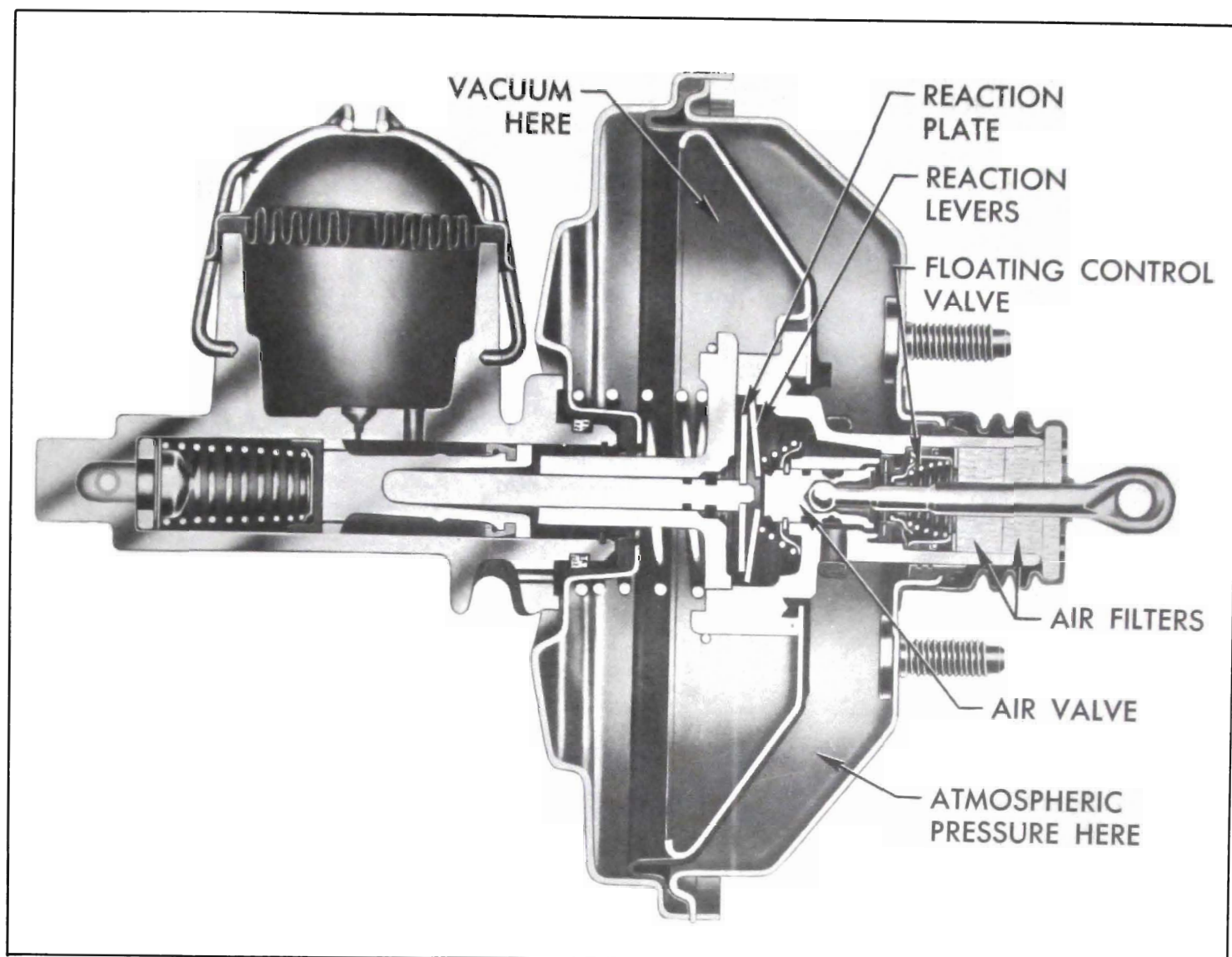

Figure 9-17—Power Brake Unit - Applying

As the power piston travels to the left, the piston rod carries the master cylinder piston into the bore of the master cylinder. After the master cylinder piston cup passes the by-pass hole, hydraulic pressure starts to build up in the hydraulic system. As the pressure builds up on the end of the master cylinder piston, the hydraulic reaction plate is moved off its seat on the reaction retainer and presses against the reaction levers. The levers, in turn, swing about their pivots and bear against the end of the air valve-push rod assembly.

In this manner, approximately 30% of the load on the piston is

transferred back through the reaction system to the brake pedal. This gives the operator a feel, which is proportional to the degree of brake application.

In case of vacuum source interruption, as the pedal is pushed down, the end of the air valve contacts the reaction levers and forces them, in turn, against the hydraulic reaction plate. Since the hydraulic reaction plate is fastened to the piston rod, it forces the piston rod against the master cylinder piston, which builds up the hydraulic line pressure.

The pedal pressure required for a manual application, such as de-

scribed, is considerably greater than with vacuum assist.

(3) Holding Position

When the desired pedal pressure is reached, the power piston moves to the left until the floating control valve, which is still seated on the power piston, again seats on the air valve. The power brake will now remain stationary, until either pressure is applied or released at the brake pedal. See Figure 9-18.

(4) Releasing Position

As the pressure at the pedal is released, the air valve spring forces the air valve back until

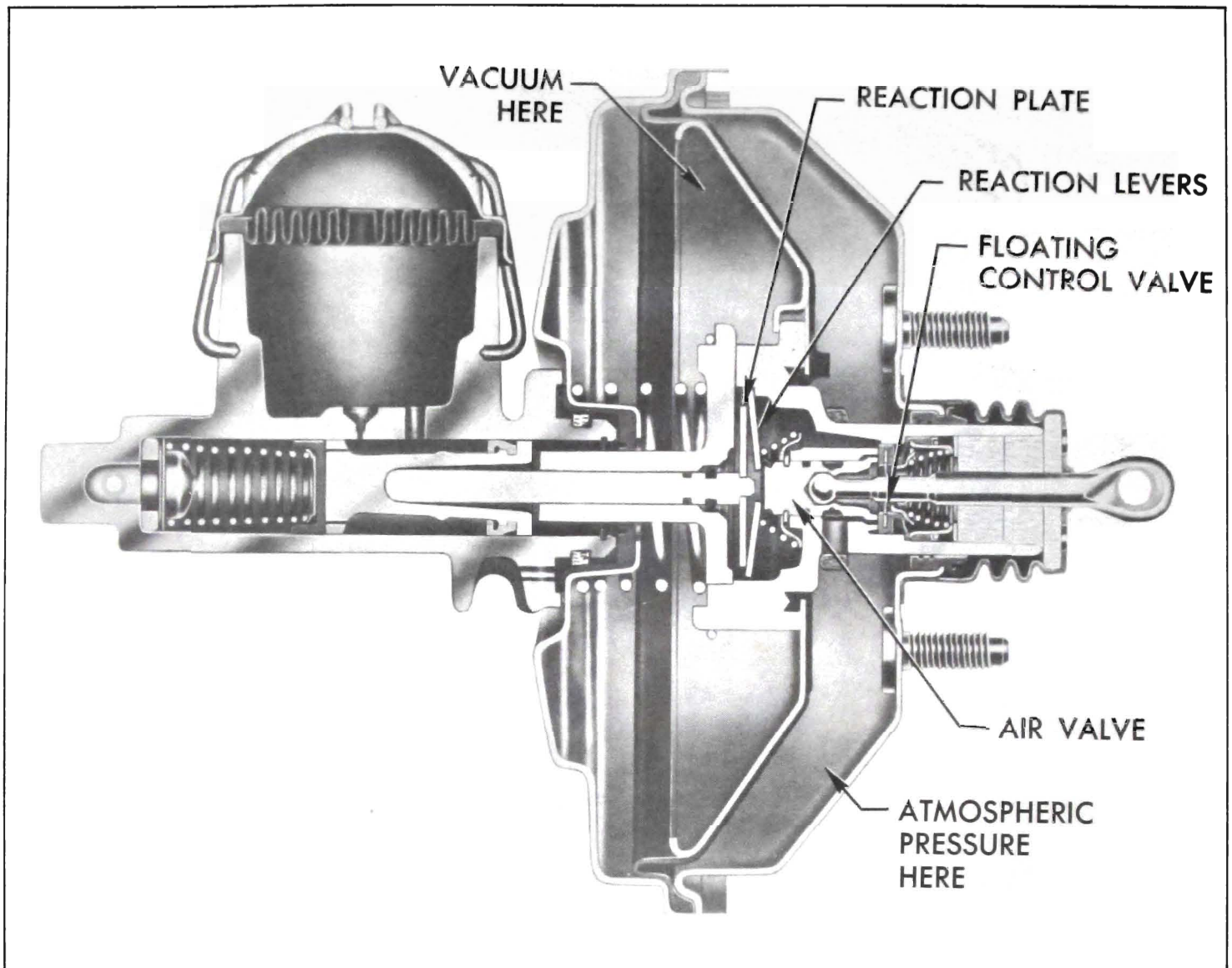

Figure 9-18—Power Brake Unit - Holding

its snap ring rests against the power piston. As it returns, the air valve pushes the floating control valve off its seat on the power piston.

The air valve seating on the floating control valve has shut off the outside air source. When it lifts the floating control valve from its seat on the power piston, it opens the space to the right of the power piston to the vacuum source.

Since both sides of the power piston are now under vacuum, the power piston return spring will return the piston to its released position against the rear housing. As the power piston is returned,

the hydraulic master cylinder piston moves back, and the fluid from the wheel cylinders flows back into the master cylinder through the check valve.

If the brake pedal is released quickly, the master cylinder piston immediately returns to the released position. If the fluid in the lines cannot return as quickly as the piston, compensation is provided for by the flow of fluid from the space between the primary cup and the secondary seal through the holes in the piston. The excess fluid in the system can flow back to the fluid reservoir through the small by-pass

hole in the master cylinder bore after the brake is released.

9-15 POWER BRAKE UNIT TROUBLE DIAGNOSIS

The same types of brake trouble are encountered with power brakes as with standard brakes. Before checking the power brake system for the source of trouble, refer to the trouble diagnosis of standard brakes in Section 9-B. After these possible causes have been eliminated, check for the cause as outlined below:

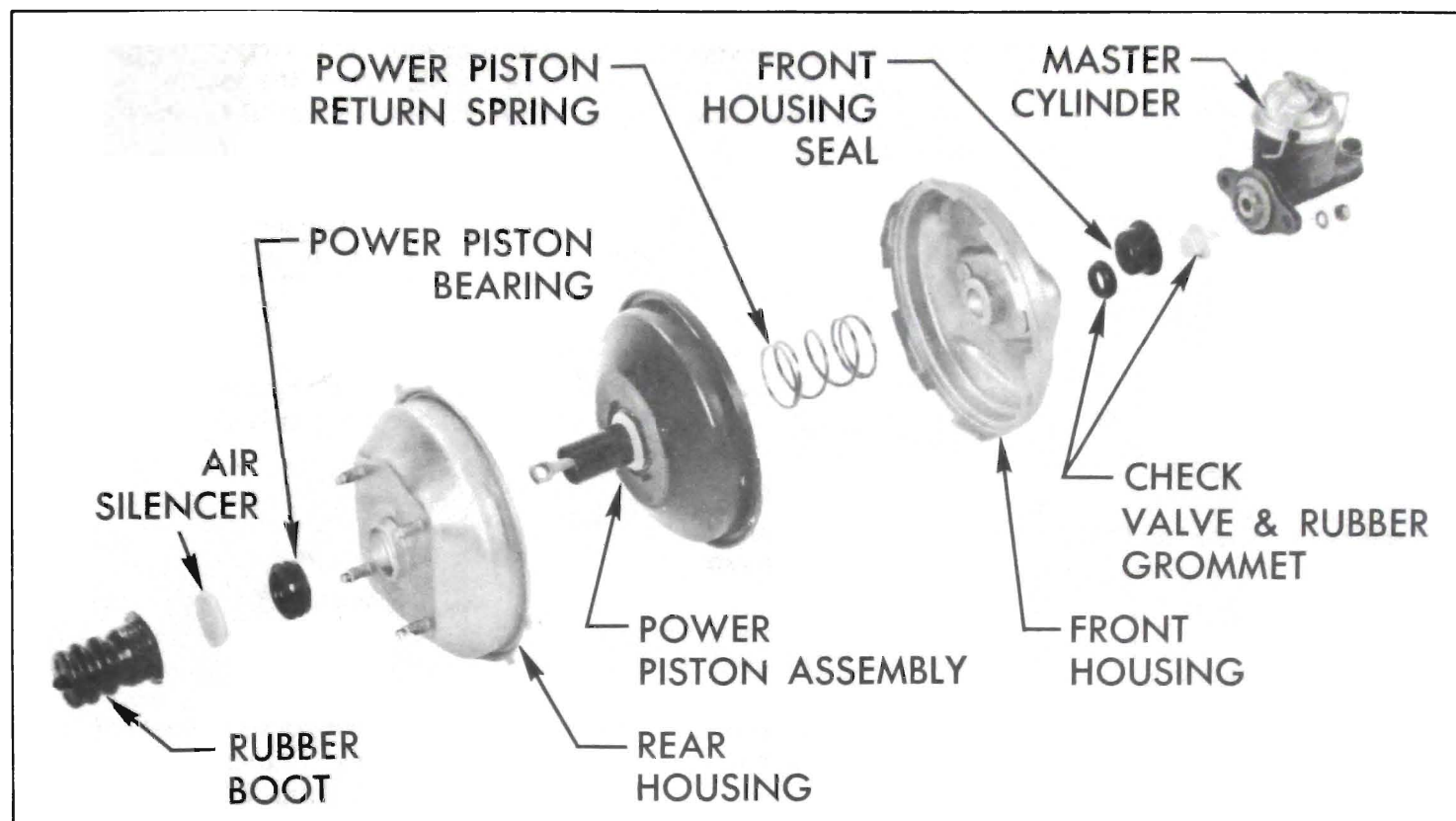

Figure 9-19—Power Brake Unit - Exploded View

a. Hard Pedal

(1) Vacuum failure due to:

- (a) Faulty vacuum check valve
- (b) Collapsed vacuum hose to manifold
- (c) Plugged or loose vacuum fittings

(2) Boundup pedal mechanism

(3) Power brake unit trouble

(a) Jammed air valve

(b) Vacuum leaks in unit caused by faulty air valve seal or support plate seal. Also, a damaged, floating control valve, bad seal of master cylinder, or power cylinder mounting studs in housings, bad seal on master cylinder push rod or a bad seal of the diaphragm bead between the housings, or at power piston. It is possible to have faulty vacuum check valve grommet.

(c) Defective rolling diaphragm

(d) Restricted air filter elements

(e) Worn or badly-distorted reaction plate or levers

(f) Cracked or broken power piston or reaction retainer.

b. Grabby Brakes (Apparent Off-and-On Condition)

(1) Power brake unit valve trouble

(a) Sticking air valve

(b) Restricted diaphragm passage

(2) Reaction system

(a) Dislodged reaction levers

(b) Broken air valve spring

(c) Worn or distorted levers or plates.

c. Pedal goes either to the Floor (or almost to Floor)

(1) Fluid reservoir needs replenishing

(2) Power brake hydraulic leakage

(a) Defective primary or secondary cups

(b) Cracked master cylinder casting

(c) Leaks at wheel cylinder in pipes or connections

(3) Faulty master cylinder check valve has permitted air to enter system, causing spongy pedal.

d. Brakes Fail to Release

(1) Faulty hydraulic check valve

(2) Blocked passage in power piston

(3) Air valve sticking shut

(4) Broken piston return spring

(5) Broken air valve spring

(6) Tight pedal linkage

9-16 REMOVAL OF POWER BRAKE UNIT

1. Disconnect brake pipe from hydraulic master cylinder and tape end of pipe to prevent entrance of dirt.

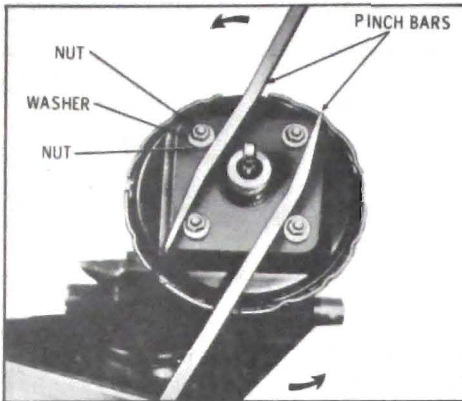

Figure 9-20—Power Brake Unit
Positioned in a Vise

2. Remove retainer and special washer from brake pedal pin and disengage push rod eye.
3. Remove four nuts holding power brake unit to dash.
4. Disconnect vacuum hose from power brake unit.
5. Remove power brake unit from car, while being careful not to drip brake fluid on exterior paint.
6. Remove filler cap and position unit so that brake fluid will drain

out. Pump push rod by hand for full interior drainage. Discard old fluid. Install filler cap and cover master cylinder outlet with tape to exclude dirt. Clean all loose dirt from outside of unit before disassembling.

9-17 DISASSEMBLY OF POWER BRAKE UNIT

a. Disassembly of Overall Unit & Front Housing Group

1. Place the power brake assembly in a vise or fixture with the push rod up. Pump the push rod three or four times to empty the master cylinder of fluid.

NOTE: Scribe a mark on the top center of the front and rear housings in line with master cylinder reservoir cover to facilitate re-assembly.

2. With the master cylinder reservoir unit firmly clamped in a vise, rotate the housings counterclockwise into the unlocked position. Use pry bars to assist removal as shown in Figure 9-20.

NOTE: Loosen housing carefully as it is heavily spring-loaded.

3. Lift the power piston assembly and rear housing from the unit.
4. Remove rubber boot and silencer from push rod.
5. Remove the power piston return spring from the front housing.

6. Reposition the master cylinder assembly in the vise to facilitate removal of the front housing from the master cylinder. Remove the two nuts and lock washers from the studs. Remove the master cylinder from the studs and lay aside.

NOTE: For master cylinder disassembly and reassembly, see Section 9-C.

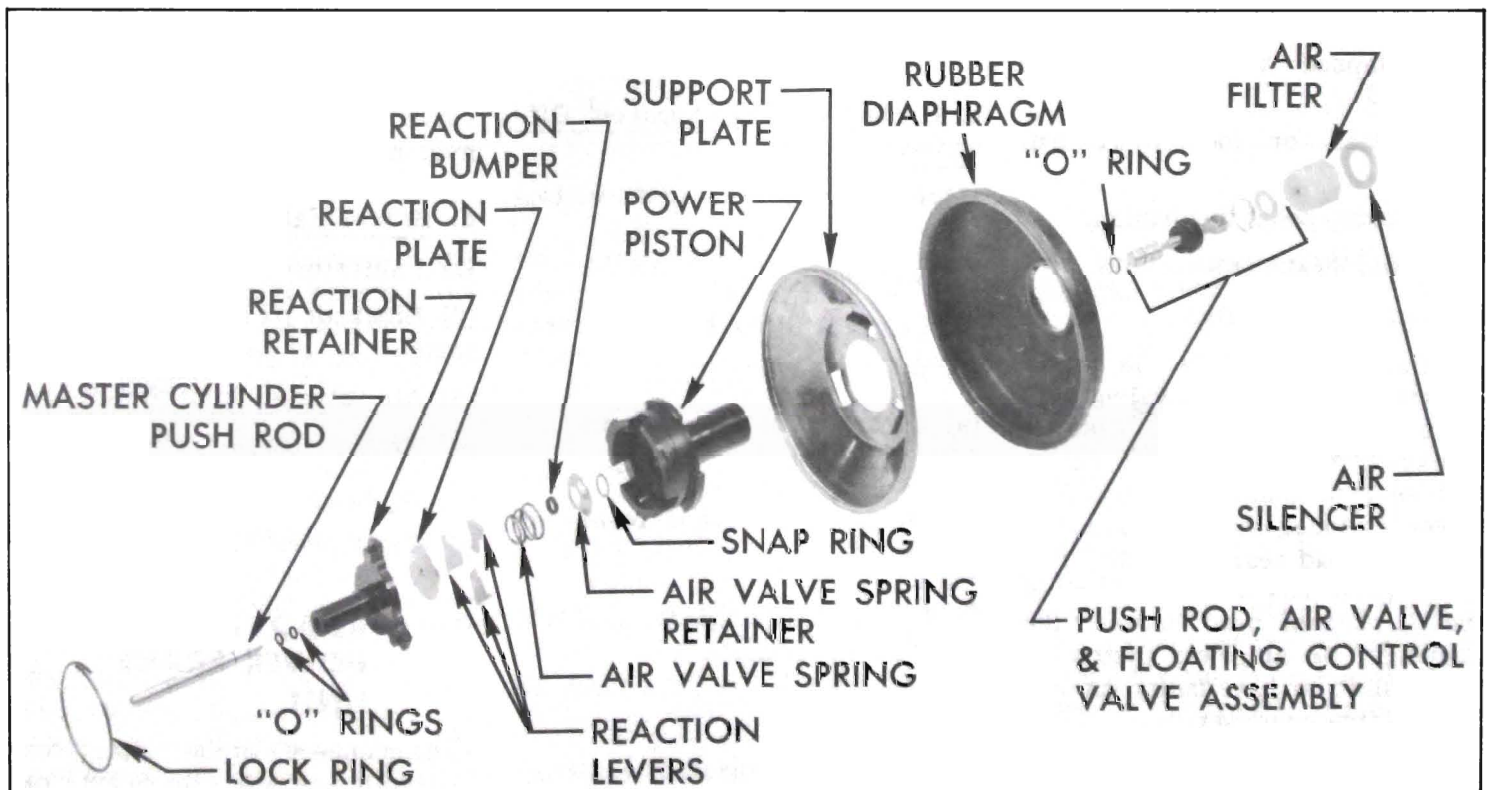

Figure 9-21—Power Piston Assembly - Exploded View

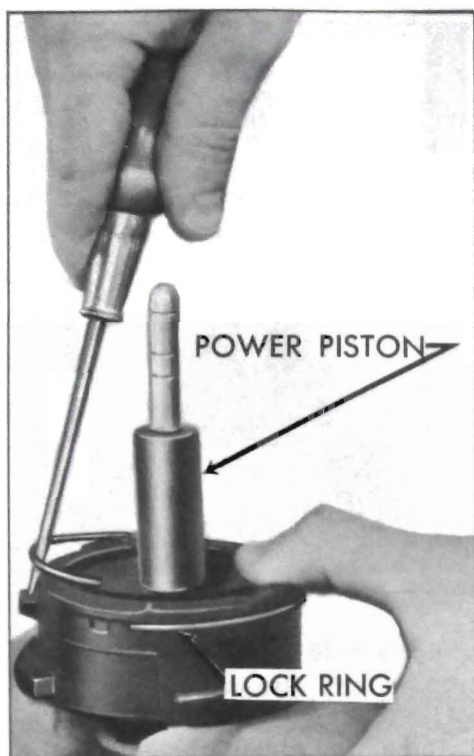

Figure 9-22—Removing Locking Ring from Power Piston

7. Remove the front housing seal from the center of the front housing. From the front housing, remove the vacuum check valve and grommet.

b. Disassembly of Power Piston Group

Caution must be taken in handling the diaphragm of the power piston group. Guard the diaphragm against grease, oil, foreign matter and nicks or cuts.

1. Remove the lock ring from the power piston by prying one of the ends out from under the large divided locking lug, and then proceed to pull it from under the other two small locking lugs on the power piston. See Figure 9-22.

2. Remove the reaction retainer, piston rod, reaction plate, three (3) reaction levers and air valve spring. Also remove the small reaction bumper and the air valve spring retainer from the air valve. See Figure 9-23.

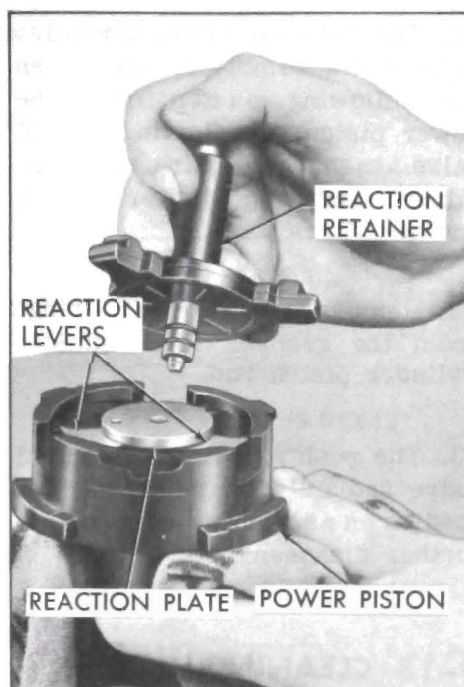

Figure 9-23—Removing Reaction Retainer

3. Place Power Piston Wrench J-21524 in vise with square shank in vise. Hold support plate and power piston with the tube of the power piston up. See Figure 9-24.

4. Pull the diaphragm edges away from the support plate, so that the hands can grip on the steel

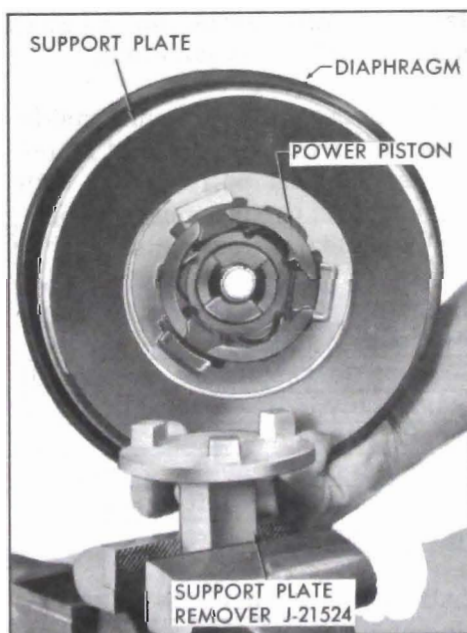

Figure 9-24—Positioning Support Plate Remover in a Vise



Figure 9-25—Positioning Power Piston on Support Plate Remover

support plate. Position the assembly down on the Power Piston Wrench J-21524 so that the three lugs on the tool fit into the three notches in the power piston. See Figure 9-25.

5. Press down on the support plate and rotate counterclockwise until the support plate separates from the power piston. See Figure 9-26.



Figure 9-26—Removing Support Plate

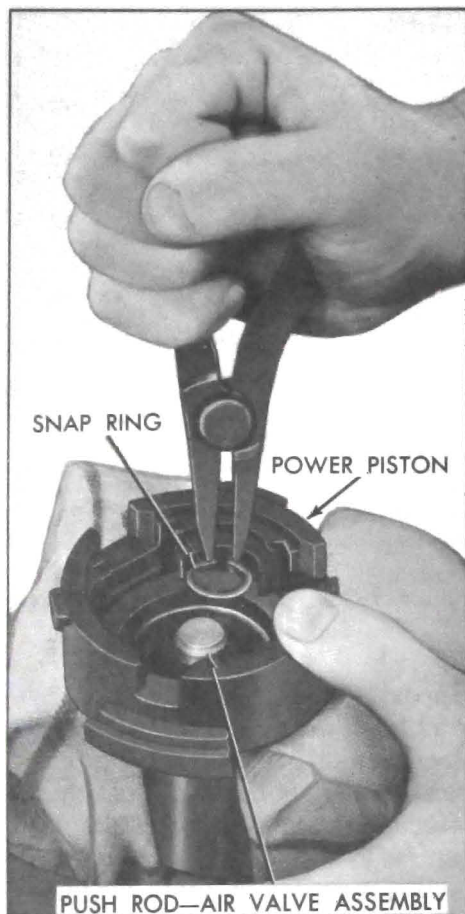

Figure 9-27—Removing Power Piston Snap Ring

6. Remove the rolling diaphragm from the support plate and lay both parts aside.

7. Remove the silencer from the neck of the power piston tube.

8. Position the power piston in a vise padded with shop towels, with the tube down (Do Not Clamp on Tube). The outside surface of the tube acts as a bearing surface.

9. Use Truarc Pliers #2, or KM J-4880, to remove the snap ring on the air valve. See Figure 9-27.

10. Set up J-6180-01 Power Ram and J-6207 Hydraulic Pump with J-8609 Press Plate. Insert power piston, tube down, in press plate, and remove air valve assembly using a 3/8" drive extension as a remover. See Figure 9-28.

11. The removal of the air valve push rod assembly disassembles the following parts from the power piston; the floating control valve assembly, floating valve retainer, push rod limiter washer and air filters.

12. Remove the two "O" rings from the grooves in the master cylinder piston rod.

13. The push rod, floating control valve and air valve must be serviced as an assembly and cannot be further disassembled.

9-18 CLEANING, INSPECTION AND REPLACEMENT OF PARTS

a. Cleaning of Parts

1. Use Del-clean or clean brake fluid to clean all metal brake parts thoroughly. Immerse in the cleaning fluid and brush with hair brush to remove foreign matter. Blow out all passages, orifices, and valve holes. Air dry and place cleaned parts on clean paper or lintfree clean cloth.

2. If slight rust is found inside either the front or rear half housing assemblies, polish clean with crocus cloth or fine emery paper, washing clean afterwards.

NOTICE: Dirt is the major cause of trouble and wear in service. Be sure to keep parts clean until reassembly. Re-wash at reassembly, if there is any occasion to doubt cleanliness -- such as parts dropped or left exposed for eight hours or longer.

CAUTION: If there is any suspicion of contamination or any evidence of corrosion, completely flush the hydraulic brake system in accordance with paragraph 9-7.

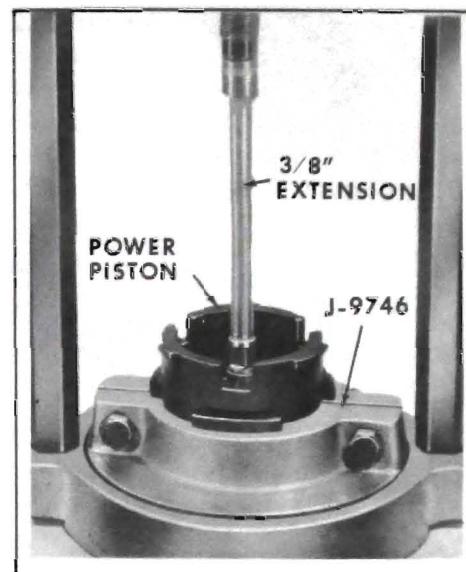

Figure 9-28—Removing Air Valve Assembly

Failure to clean the hydraulic brake system can result in early repetition of trouble. Use of gasoline, kerosene, anti-freeze alcohol or any other cleaner, with even a trace of mineral oil, will damage rubber parts.

b. Inspection & Replacement of Parts

1. Inspect all rubber parts. Wipe free of fluid and carefully inspect each rubber part for cuts, nicks, or other damage. These parts are the key to the control of fluid or air flow, and should account for the majority of troubles traceable to leakage. Re-use rubber parts only if a fairly new Unit is dismantled for some particular trouble, and only then if there is no doubt that the parts are in equal-to-new condition. Badly damaged items, or those which would take extensive work or time to repair, should be replaced. In case of doubt, install new parts for safety and for ultimate lower cost.

2. Inspect in accordance with the following table: (The table is organized by power brake unit groups.)

a. Master Cylinder Group - see Section 9-C

b. Power Piston Group

PART	INSPECT FOR	CORRECTIVE ACTION
Power Piston & support plate & Reaction Retainer.	Cracks, distortion, chipping, damaged lever seats, pitted or rough holes.	Cleanup or replace.
	Worn seal surfaces (tubes).	
	Rough or uneven floating valve seat.	Replace.
	Open passages and flow holes.	Clean.
Reaction Levers or Plates	Cracks, deformation, tears, and heavy wear.	Replace.
Floating Control Valve.	Deterioration of rubber or warped valve face.	Replace.
Air Valve-Push Rod Assembly.	Air valve: scratches, dents, distortion, or corrosion of I.D. or O.D. All seats to be smooth and free of nicks and dents.	Do not repair; replace.
	Push rod must move freely in air valve, but must not pull out.	If worn, replace air valve- push rod assembly.

c. Over-All Unit

PART	INSPECT FOR	CORRECTIVE ACTION
Front & Rear Half Housing.	Scratches, scores, pits, dents or other damage affecting rolling or sealing of diaphragm or other seals.	Replace unless easily repaired.
	Cracks, damage at ears, dam- aged threads on studs.	Replace unless easily repaired.
	Bent or nicked locking lugs.	Replace unless easily repaired.
	Loose studs.	Replace or repair.
Air Filters & Silencer	Dirty.	Replace.

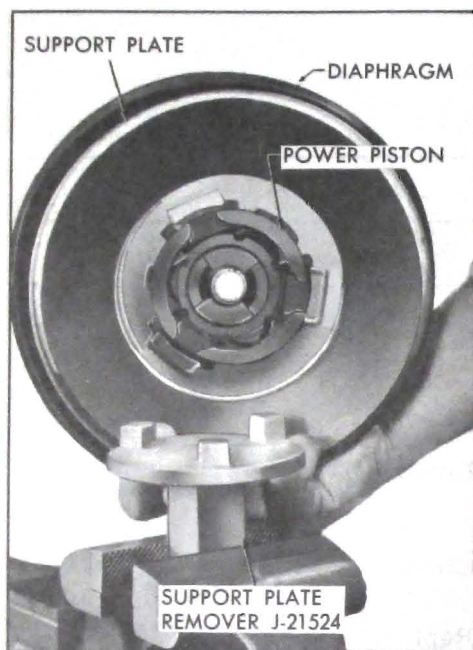

Figure 9-29—Positioning Power Piston in Wrench

9-19 ASSEMBLY OF POWER BRAKE UNIT

Be certain that all rubber parts are clean at reassembly. Re-wash in Del-clean or clean brake fluid, if there is any doubt of cleanliness. Be careful during the rebuild process that no grease or mineral oil comes in contact with the rubber parts of the power brake unit. Lubricate rubber parts with Delco Moraine approved lubricant or equivalent.

a. Assembly of Front Housing Group

1. Replace the vacuum check valve, using a new grommet, if old one is cracked or damaged.
2. Place new front housing seal in the center of the front housing so that the flat surface of the cup lies against the bottom of depression in the housing.

b. Assembly of Power Piston Group

On reassembly of the power piston, if the push rod, air valve,

and floating control valve have been removed, they must be replaced as an assembly with new parts. Removing the push rod distorts component parts in the floating control valve mechanism.

1. Place two new "O" rings in the grooves on the master cylinder piston rod. Wipe a thin film of #5459912 Power Brake Lube or equivalent on the "O" rings.

2. The master cylinder piston rod is now inserted through the reaction retainer so that the round end of the piston rod protrudes from the end of the tube on the reaction retainer.

3. Place the Power Piston Wrench, J-21542 in a vise. Position the power piston on the wrench with the three lugs fitting into the notches in the power piston. See Figure 9-29.



Figure 9-30—Seating Floating Control Valve Assembly

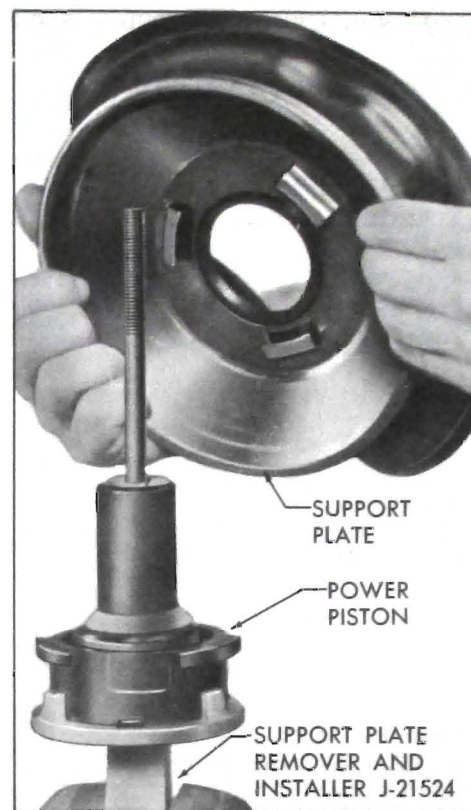

Figure 9-31—Installing Power Piston into Support Plate

4. Wipe a thin film of power brake lube on the large O.D. of the floating control valve and on the "O" ring on the air valve.

5. Start the air valve-push rod-floating control valve assembly into the tube of the power piston.

6. Use J-21601 Floating Control Valve Retainer Installer to manually press assembly and retainer to seat in tube. See Figure 9-30.

7. Install filter elements by stretching over end of push rod and pressing into tube.

8. Assemble the power piston diaphragm to the diaphragm support plate from the side of the support plate opposite the locking tangs. The raised flange of the diaphragm is pressed through the hole in the center of the support plate. Be sure that the edge of the center hole fits into the groove in the flange of the diaphragm.

9. Pull the diaphragm away from the O.D. of the support plate so

that the metal of the support plate can be gripped with the hands.

10. With power piston still positioned on the holding tool in vise, coat bead of diaphragm that contacts power piston with Power Brake Lube.

11. Holding the support plate on the bare metal, with the locking tangs down, place the support plate and diaphragm assembly down over the tube of the power piston. The flange of the diaphragm will fit into the groove on the power piston. See Figure 9-31.

12. Press down and rotate the support plate counterclockwise, until the lugs on the power piston come against the stops on the support plate.

13. This assembly can now be turned over and placed, tube down, in a padded vise (Do Not Clamp).

14. With a pair of #2 Truarc or #J-4880 Pliers, assemble the snap ring into the groove in the air valve.

15. Place the air valve spring retainer to seat on the snap ring. Assemble the reaction bumper into the groove in the end of the air valve.

16. Position the air valve return spring, large end down, on the spring retainer.

17. The three reaction levers are now placed into position with the ears on the wide end, in the slots provided for them in the power piston. The narrow ends will rest on the top of the air valve return spring.

18. Position the reaction plate (with numbered side up) on top of the reaction levers. Press down on the plate until the large ends of the reaction levers pop up so that the plate rests flat on the levers. Be sure the reaction plate is centered.

19. The master cylinder piston rod and reaction retainer assembly is now assembled to the power piston.

20. With the round end of the piston rod up, and with the reaction retainer held toward the top of the piston rod, place the small end of the piston rod in the hole in the center of the reaction plate. Line up the ears on the reaction retainer with the notches in the power piston and push the reaction retainer down until the ears seat in these notches.

21. Maintain pressure on the reaction retainer and position the large lock ring down over the master cylinder push rod.

22. There is a lug on the power piston which has a raised divider in the center. One end of the lock ring goes under the lug and on one side of the divider. See Figure 9-32.

23. As you work your way around the power piston (either way) the lock ring goes over the ear of the reaction retainer, under a lug on

the power piston, and so forth, until the other end of the lock ring is seated under the lug with the raised divider.

Be sure both ends of the lock ring are securely under the large lug.

c. Assembly of Rear Housing Group

1. Place a new power piston bearing in center of rear housing so that the flange on the center hole of housing fits into the groove of the power piston bearing. The large flange on the power piston bearing will be on the stud side of the housing.

2. Coat the inside of the power piston bearing with Power Brake Lube.

d. Final Assembly of Power Brake Unit

1. Place the air silencer over the holes on the tube of the power piston. Wipe the tube of the power piston with Power Brake Lube.

2. Assemble the power piston to the rear housing by pushing the tube of the power piston through the rear housing from the side opposite the studs.

3. Wipe tube of the reaction retainer with Power Brake Lube and lay the assembly aside.

4. Place the front housing in a vise with the master cylinder down. Position power piston return spring over the inset in the front housing. Lubricate the I.D. of the support plate seal with Power Brake Lube.

5. Lubricate lightly with talcum powder the beaded edge of the diaphragm. Hold the rear housing and power piston assembly over the front housing with the master cylinder push rod down. Position the rear housing so that when it is rotated into the locked position, the scribe marks on the housings will be in line.

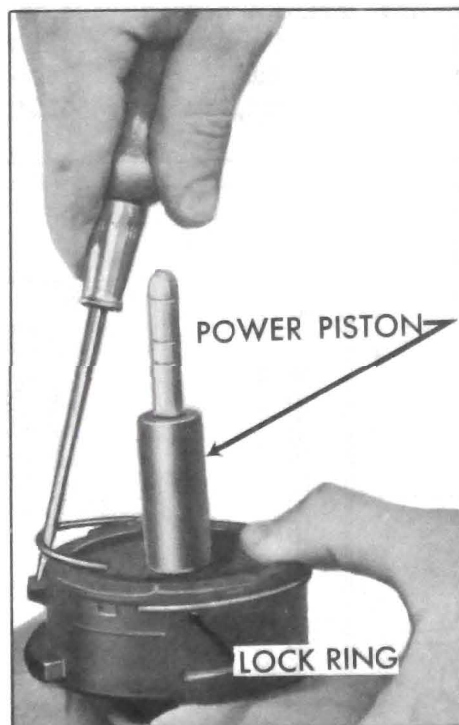

Figure 9-32—Installing Power Piston Lock Ring

6. Using pry bars as shown in Figure 9-20, rotate housing into the locked position.

CAUTION: Make certain nuts are installed on studs so that threads do not become damaged and be extremely careful not to break the studs loose in the rear housing. Also, do not put pressure on the power piston tube when locking the housings.

7. Push the felt silencer over the push rod to seat against the end of the power piston tube. The snap ring retainer is now placed on the push rod so that it can hold the silencer against the power piston tube. The plastic boot is now pushed to seat against the rear housing. The raised tabs on the side of the boot will locate in the large holes in the center of the brackets. The jam nut and clevis can now be re-assembled to the push rod.

e. Gauging Power Brake Piston

The following gauging operation is necessary only when a major structural part such as the front or rear housing, the power piston assembly, the master cylinder

piston, or the master cylinder assembly is replaced with a new part. The gauge measures how far the master cylinder push rod projects from the front housing. This dimension must be correct to insure the proper clearance in the master cylinder between the primary cup and the compensating port.

Make check as follows:

1. Place the power brake assembly in a vise so that the master cylinder is up. Remove the master cylinder from the front housing. The master cylinder push rod is now exposed.

2. Place Gauge J-7723-01 over the piston rod so that it fits between the two studs on the front housing. It should be parallel to the studs and resting on the surface of the housing. The cutout portion of the gauge should never be lower than the end of the piston rod, and the gap between the cutout in the gauge and the end of the piston rod should never be more than .010 inch. See Figure 9-33.

3. Any variation beyond these two limits must be compensated for by obtaining the service adjustable piston rod, Part #5464521,

and adjusting the screw in the end to match the height of the gauge.

4. Replace the master cylinder on the studs on the front housing. Install nuts and lock washers on the studs and torque to 15-20 ft. lbs.

CAUTION: When replacing the unit on the vehicle, start the engine and allow vacuum to build up before applying the brake.

9-20 INSTALLATION OF POWER BRAKE UNIT

1. Place power brake unit in position on cowl and install four nuts on studs. Torque nuts to 20-28 ft. lbs.

2. Using retainer and special washer, connect push rod clevis to brake pedal pin. Adjust pedal height as indicated in paragraph 9-8.

3. Connect brake pipe to master cylinder.

4. Connect vacuum hose to check valve on power brake housing.

5. Bleed hydraulic system according to procedure in paragraph 9-7.

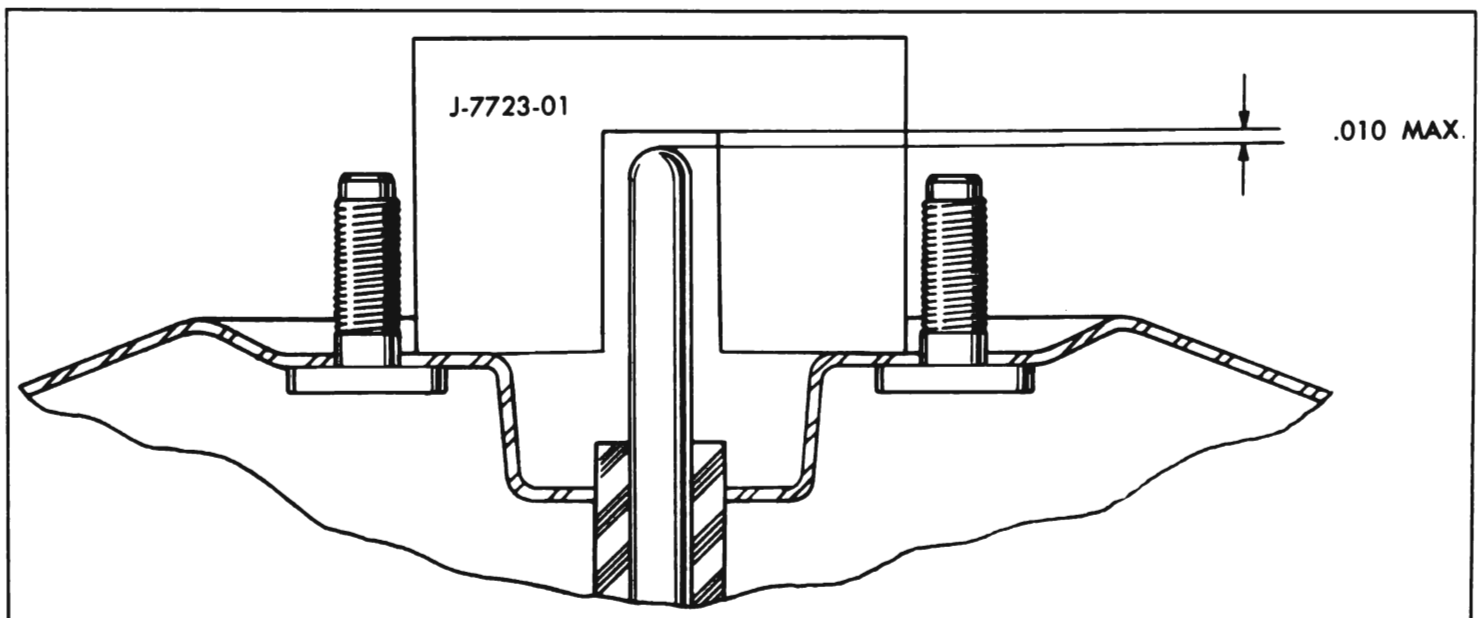

Figure 9-33—Gauging Master Cylinder Push Rod

6. After bleeding, bring fluid level to 1/8" below reservoir lid. Install rubber diaphragm and master cylinder lid.

NOTE: When pressure bleeding equipment is not available, do not use any vacuum assist. The engine should not be running and the vacuum reserve should be used up by repeatedly applying the brake before starting the bleeding procedure.

9-21 TESTING OF POWER BRAKE UNIT

1. Road test the brakes by making a brake application at about 20

MPH to determine if the vehicle stops evenly and quickly. If the pedal has a spongy feel when applying the brakes, air may be present in the hydraulic system. Bleed system as described in paragraph 9-7.

2. When the engine is stopped and the transmission is in neutral, apply brakes several times to deplete all vacuum reserve in the system. Depress brake pedal, hold light-foot pressure on the pedal, and start the engine. If the vacuum system is operating, the pedal will tend to fall away under foot pressure, and less pressure will be required to hold pedal in applied position. If no action is felt, the vacuum system is not functioning.

3. Stop engine. Again deplete all vacuum reserve in the system. Depress the brake pedal and hold foot pressure on the pedal. If the pedal gradually falls away under foot pressure, the hydraulic system is leaking.

4. If the brake pedal travels to within one inch of the toeboard, the brake shoes require adjustment or relining.

5. Start engine. With brakes off, run to medium speed and turn off the ignition. Immediately close the throttle. This builds up vacuum. Wait no less than 90 seconds, then try brake action. If not vacuum-assisted for two or more applications, vacuum check valve is faulty or there is a leak in the vacuum system.