

# GROUP 9 BRAKES

## SECTIONS IN GROUP 9

Section	Subject	Page	Section	Subject	Page
9-A	Brake Specifications, Description, Operation . . . . .	9-1	9-C	Brake Service, Adjustment Repair Procedures . . . . .	9-14
9-B	Brake Trouble Diagnosis . . . . .	9-10	9-D	Delco Moraine Power Brakes . . . . .	9-23
			9-E	Bendix Power Brakes . . . . .	9-38

## SECTION 9-A

### BRAKE SPECIFICATIONS, DESCRIPTION, OPERATION

#### CONTENTS OF SECTION 9-A

Paragraph	Subject	Page	Paragraph	Subject	Page
9-1	Brake Specifications . . . . .	9-1	9-3	Operation of Hydraulic Service Brakes . . . . .	9-8
9-2	Description of Brake Mechanism . . . . .	9-2			

## 9-1 BRAKE SPECIFICATIONS

### a. Tightening Specifications

Use a reliable torque wrench to tighten the parts listed, to insure proper tightness without straining or distorting parts. These specifications are for clean and lightly lubricated threads only; dry or dirty threads produce increased friction which prevents accurate measurement of tightness.

Name	Thread Size	Torque-Ft. Lbs.
Nut Brake Pedal Pivot Shaft to Mounting Bracket . . . . .	5/16-24	10-15
Screw Wheel Cylinder to Brake Backing Plate . . . . .	5/16-18	10-15
Nut Brake Cylinder and Pedal Mounting Bracket to Dash (Standard and Power). . . . .	3/8-16	20-28
Bolt & Nut Brake Assembly and Steering Arm to Knuckle, Front - 49000 . . . . .	7/16-14	60-85
Bolt & Nut Brake Assembly and Steering Arm to Knuckle, Rear - 49000 . . . . .	1/2-13	90-120
Bolt & Nut Brake Assembly and Steering Arm to Knuckle, Front - 45, 46, 48000 . . . . .	1/2-13	90-120
Nut Rear Brake Assembly to Axle Housing . . . . .	3/8-16	40-55
Bolt Brake Assembly through Anchor Pin to Knuckle . . . . .	9/16-18	130-150
Nut Front Wheel to Hub . . . . .	1/2-20	65-85
Nut Rear Wheel and Brake Drum to Axle Shaft . . . . .	1/2-20	65-85

### b. General Specifications

Items	
Operating Mechanism, Service Brakes . . . . .	Hydraulic
Parking Brakes . . . . .	Lever and Cables
Operation of Service Brakes Independent of Parking Brakes . . . . .	Yes
Wheels Braked, Service . . . . .	Front and Rear
Parking . . . . .	Rear Only
Approx. % of Total Braking Power on—Front Wheel Brakes . . . . .	56
Rear Wheel Brakes . . . . .	44

**b. General Specifications (Cont'd)**

Items	
Brake Pedal Height Adjustment, Standard and Power . . . . .	None
Static Pressure in Hydraulic System when Brakes are Released . . . . .	8 to 16 lbs.
Number of Brake Shoes at Each Wheel . . . . .	2
Brake Type . . . . .	Self Energizing-Servo
Brake Shoe Lining Type . . . . .	1 pc. Molded-Riveted
Front Shoe Lining Width x Minimum Thickness . . . . .	2.25" x .220" Primary: 2.25" x .254 Secondary
Rear Shoe Lining Width x Minimum Thickness . . . . .	2.00" x .220" Primary: 2.25" x .254 Secondary
Front Brake Drum, All Series Except 45000 . . . . .	Finned Aluminum with C.I. Liner
Front Brake Drum, 45000 . . . . .	Finned Cast Iron
Master Cylinder Piston Dia., Standard and Power . . . . .	1"
Wheel Cylinder Size, Front . . . . .	1 1/8"
Rear . . . . .	1"
Approved Hydraulic Brake Fluid . . . . .	GM or Delco Super No. 11 or equiv.
Fluid Level, Below Lip of Reservoir Opening . . . . .	1/8"
Shoe Adjusting Screw Setting, from Point where Wheels can just be turned by hand . . . . .	Back Off 30 Notches
Brake Drum Inside Diameter, New . . . . .	11.997" to 12.022"
Brake Drum Rebore, Max. Allowable Inside Diameter . . . . .	12.080"
Max. Allowable Taper, Before Rebore . . . . .	.005"
Max. Allowable Out-of-Round, Before Rebore . . . . .	.010"
Max. Allowable Out-of-Balance of Drum . . . . .	3 in. oz.
Max. Allowable Space Between Lining and Shoe Rim after Riveting . . . . .	.005"

**9-2 DESCRIPTION OF BRAKE MECHANISM**

The brake mechanism includes a brake drum and a brake assembly at each wheel, and two separate and independent control systems for applying the brakes-- (1) Parking brake control system (2) Service brake control system with self-adjusting mechanism.

**a. Wheel Brake Assemblies**

All rear brake drums consist of a cast iron rim fused to a pressed steel disk. The cast iron rim provides an ideal braking surface and increases brake lining life. External ribs and fins aid in dissipation of heat.

Front brake drums on the 46, 48, 49000 Series are cast aluminum alloy with a cast iron liner. The aluminum section has ribs and fins for better heat dissipation while the cast iron liner provides the best braking surface. The lighter 45000 Series has finned all-cast iron drums.

The brake assembly at each wheel uses a primary (front) and secondary (rear) brake shoe of welded steel construction, with one-piece lining attached by tu-

bular rivets. The primary shoe lining is shorter and thinner, than the secondary shoe lining and is of different composition; therefore the two shoes are not interchangeable. See Figure 9-1.

Each brake shoe is held against the backing plate by a hold-down spring, pin, and cup which allow free movement of the shoe. The notched upper end of each shoe is held against the single fixed anchor pin by a heavy coil spring. An adjusting screw and lock spring connects the lower ends of both shoes together and provides adjustment for clearance with the brake drum.

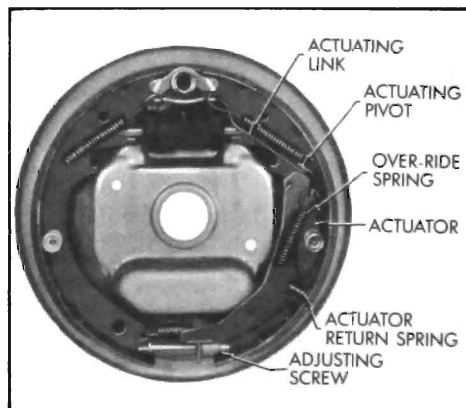

Figure 9-1—Right Rear Wheel Brake Assembly

A hydraulic wheel cylinder mounted on the backing plate between the upper ends of the brake shoes forces the shoes against the brake drum when the service brakes are applied. On rear wheels only, a lever mounted on each secondary shoe and connected to the primary shoe by a strut is used for applying the shoes when used as parking brakes. See Figure 9-1.

When the brake shoes contact the rotating drum, in either direction of car travel, they move with the drum until the rearward shoe is stopped by the anchor pin and the forward shoe is stopped by the rearward shoe through the connecting adjusting screw. Frictional force between drum and shoe lining tries to rotate each shoe outward around its anchor point but the drum itself prevents this rotation; consequently the shoes are forced more strongly against the drum than the applying force is pushing them. See Figure 9-2. It is also evident that the force applied by the drum to the forward shoe is imparted to the rearward shoe through the connecting adjusting screw.

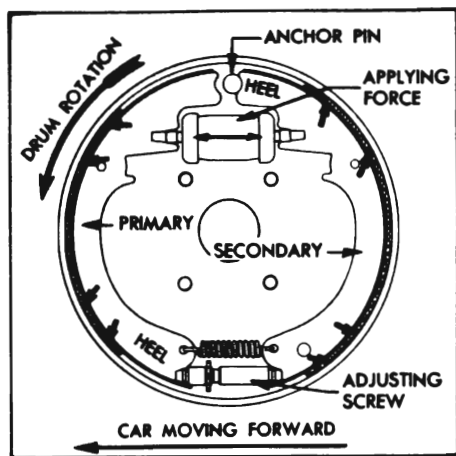

Figure 9-2—Brake Shoe Action

Utilization of the frictional force to increase the pressure of shoes against the drum is called self-energizing action. Utilization of force in one shoe to apply the opposite shoe is called servo action.

**b. Parking Brake Control System**

On the 49000 Series, the foot-operated parking brake is connected by a parking brake lever connected by a parking brake lever cable to an idler lever located between the frame rails just forward of the frame tunnel. An adjustable clevis at the rear end of this cable is used to properly position the idler lever. A return spring returns the idler lever to its rearward position and, at the same time, returns the cable and parking brake lever to the released position. An equalizer is connected to the center of the idler lever and a ball on the forward end of each rear cable engages a slot in this equalizer. See Figure 9-3 and 9-4.

On the 45, 46, and 48000 Series the parking brake control system

uses a foot-operated lever, conduit enclosed front cable, non enclosed connecting cables, and brake shoe levers and struts. By means of an equalizer, the front parking brake cable is connected to the forward portion of a center cable. This center cable is routed rearward from the equalizer through retaining guides which attach to right and left side frame rails. The center cable attaches at either end to a rear cable assembly.

On all Series, the rear end of each rear brake cable is attached to the free lower end of a brake shoe lever pivoted on each secondary (rear) brake shoe. A strut is mounted between each brake shoe lever and the primary (front) brake shoe. See Figure 9-1.

When the foot-operated brake lever is pushed forward the

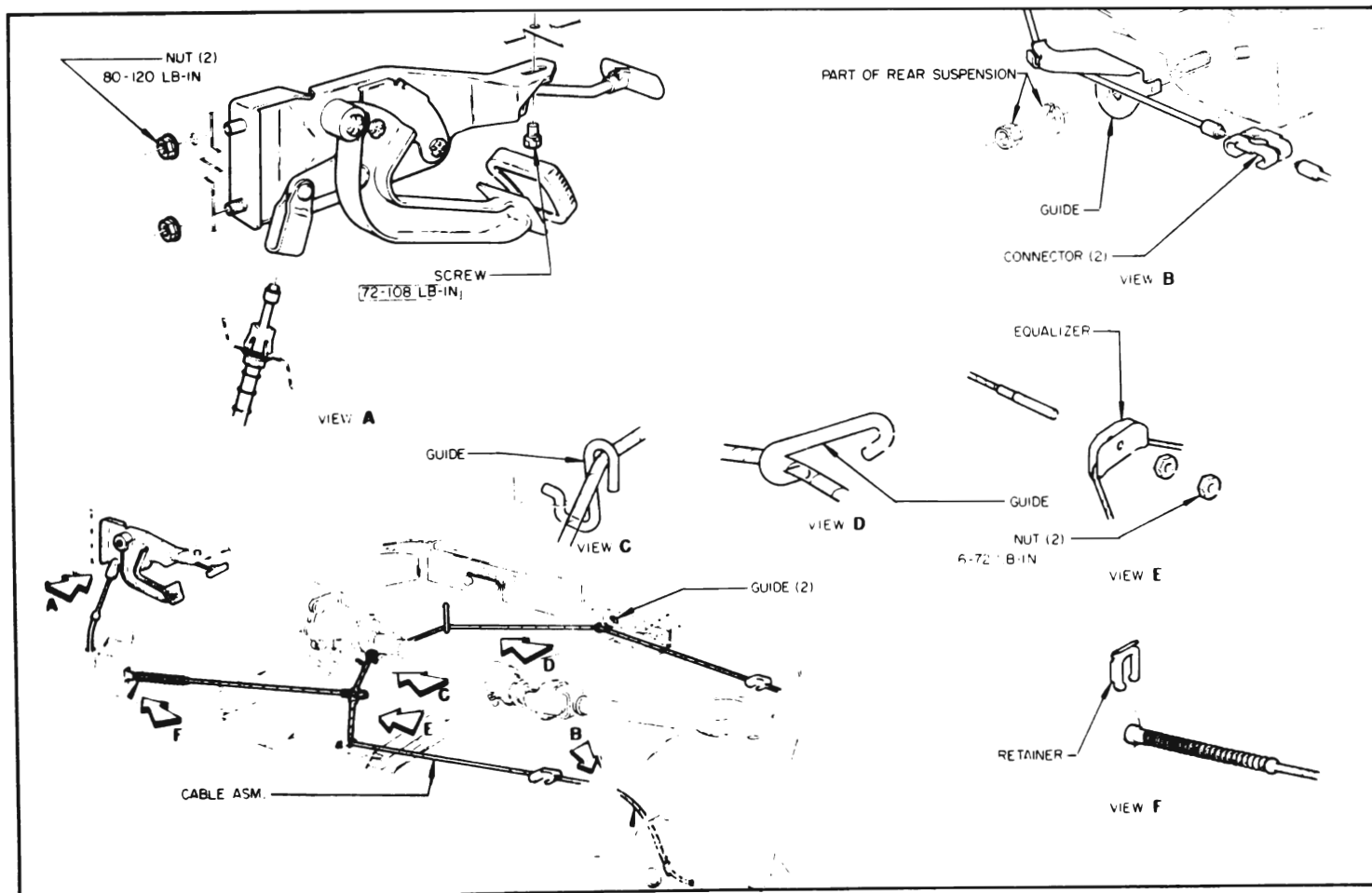

Figure 9-3—Parking Brake Mechanism - 45, 46, 48000 Series

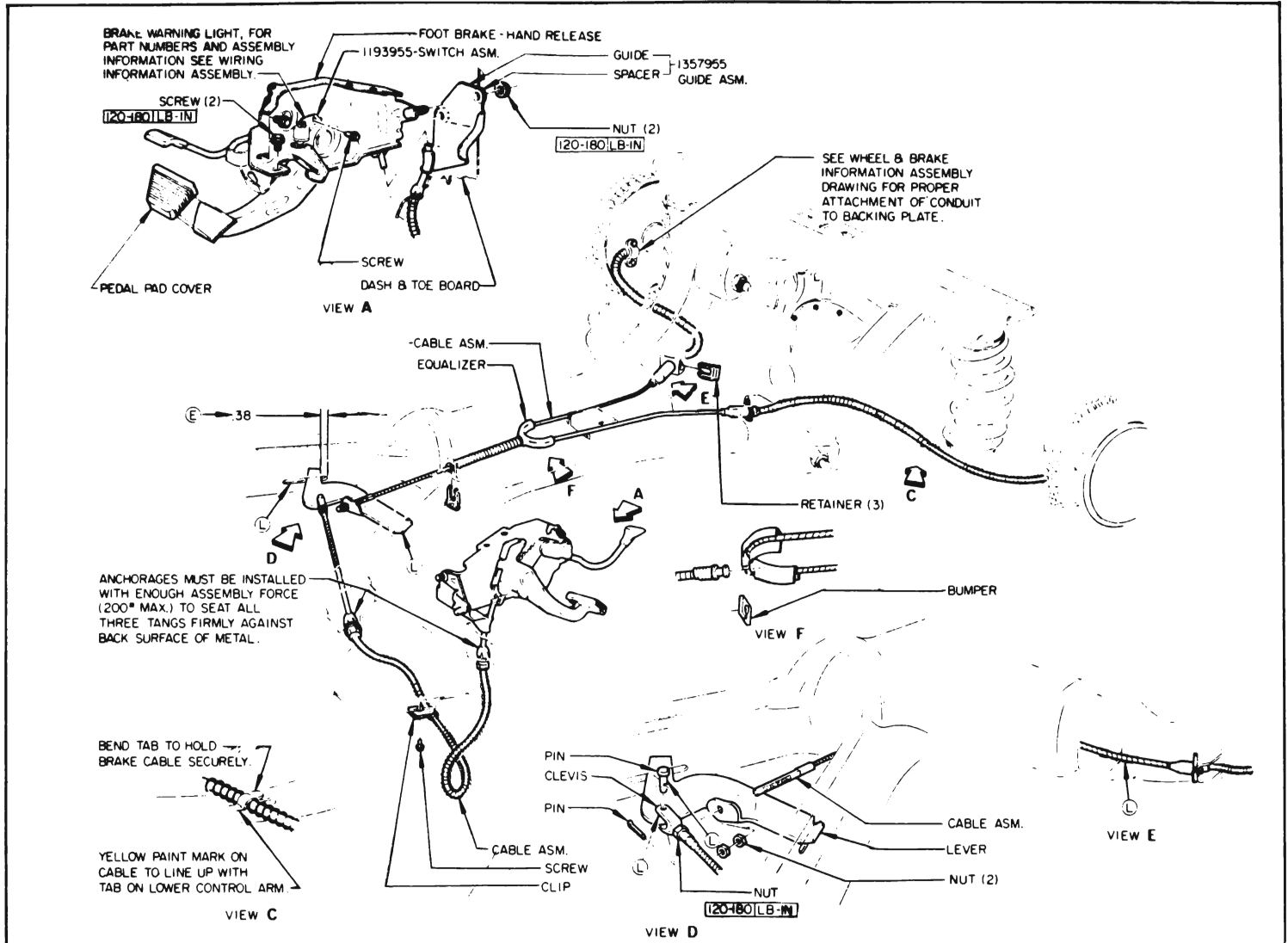

Figure 9-4—Parking Brake Mechanism - 49000 Series

cables apply an equal pull to each brake shoe lever, and the levers and struts force all rear brake shoes into firm contact with the brake drums. A spring-loaded latch automatically locks the brake lever to keep the parking brakes applied. The brake lever is released by pushing down (49000), pulling (45, 46, 48) on the release knob. A warning signal, which is standard on 48, 49000 Series and optional on Series 45, 46000, will show a red light on instrument panel if the car is operated with the parking brakes applied.

### c. Service Brake Control System—Standard Brakes

NOTE: See Sections 9-D and 9-E

for power brakes.

The regular foot-powered service brake control system is a pedal operated hydraulic system which applies the brakes at all four wheels with equalizer pressure.

The hydraulic system consists of one master cylinder connected by pipes and flexible hoses to a wheel cylinder mounted between the brake shoes at each wheel. The master cylinder, pipes, hoses and four wheel cylinders are filled with brake fluid. The stop light switch is mounted on a bracket just rearward of the brake pedal shank. With the brakes fully released, the switch plunger is fully depressed against an operating plate on the pedal

shank. See Figures 9-7 and 9-8. A coiled brake pipe extends downward from the master cylinder to a distributor located on the left frame rail. A brake pipe extends rearward from the distributor to a hose located inside the left frame rail, on 49000 Series, and located near center of spring cross member on the 45-46-48000 Series. This hose is connected to a tee located on the axle housing. Two pipes lead off from the tee, one to the left rear wheel cylinder and the other to the right rear wheel cylinder. See Figures 9-5 and 9-6.

The brake pedal is suspended from a pivot shaft in the pedal bracket. The master cylinder

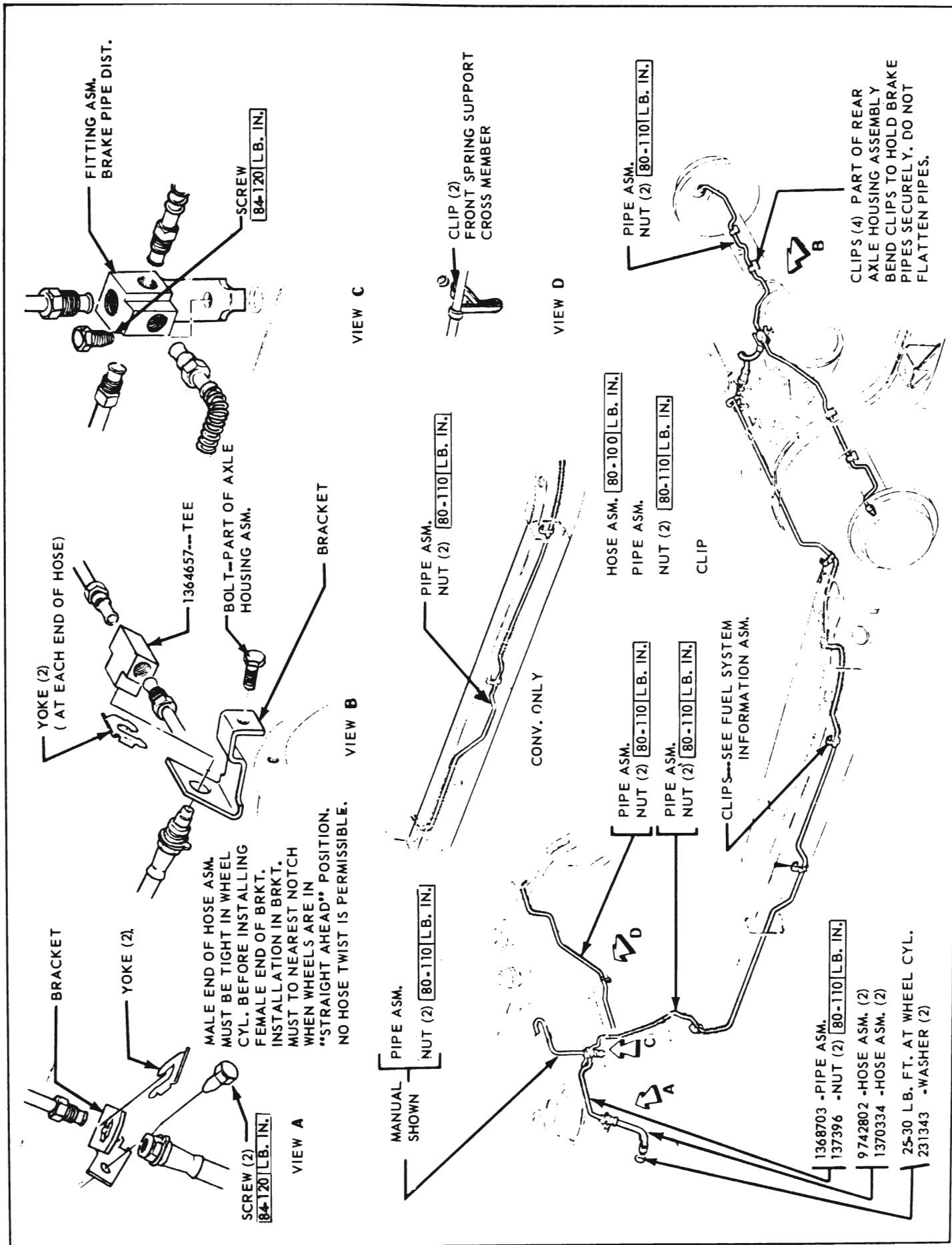

Figure 9-5—Service Brake Control System - 45, 46, 48000 Series



push rod eye attaches to a pin on the shank of the pedal. The overall mechanical advantage in the standard brake linkage is 6 to 1. See Figures 9-7, and 9-8.

The pivot shaft in the brake pedal has nylon bushings which are lubricated during installation but do not require periodic lubrication. Whenever the linkage is disassembled, however, all friction

surfaces should be lightly coated with Lubriplate. Because there is no pedal stop, the pedal is stopped in the "off" position by contact of the push rod with the stop plate in the master cylinder. No linkage adjustment is possible; therefore pedal height cannot be changed. The master cylinder contains a fluid reservoir and a cylindrical pressure chamber in which force

applied to the brake pedal is transmitted to the fluid which actuates the brake shoes. Between the pressure chamber and the fluid reservoir, a breather port and compensating port permit passage of fluid during certain operating conditions. A vented cover and flexible rubber diaphragm, at the top of the master cylinder reservoir, seal the hydraulic system from possible entrance of contamination, while at the same time permitting expansion or contraction of fluid within the reservoir without direct venting. In the pressure chamber, a coil spring holds a rubber primary cup against the inner end of the piston. This cup and a rubber secondary seal on the outer end of the piston prevent escape of fluid past the piston. The piston is retained in the cylinder by a stop plate, and a rubber boot is installed over this end of the cylinder to exclude foreign matter.

Each wheel cylinder contains two pistons and two rubber cups which are held in contact with the pistons by a central coil spring with cup expanders to provide a fluid-tight seal. The wheel cylinder cups are of a special heat resisting rubber. Cups of this material must have an expander to hold the lips of the cup out against the wheel cylinder bore. These cup expanders are crimped on each end of the wheel cylinder spring. The inlet port for brake fluid is located between the pistons so that when fluid pressure is applied both pistons move outward towards the ends of wheel cylinders. The pistons impart movement to the brake shoes by means of connecting links which seat in pistons and bear against webs of shoes. Rubber boots enclose both ends of cylinder to exclude foreign matter. A valve for bleeding the brake pipes and wheel cylinder is located above the inlet port.

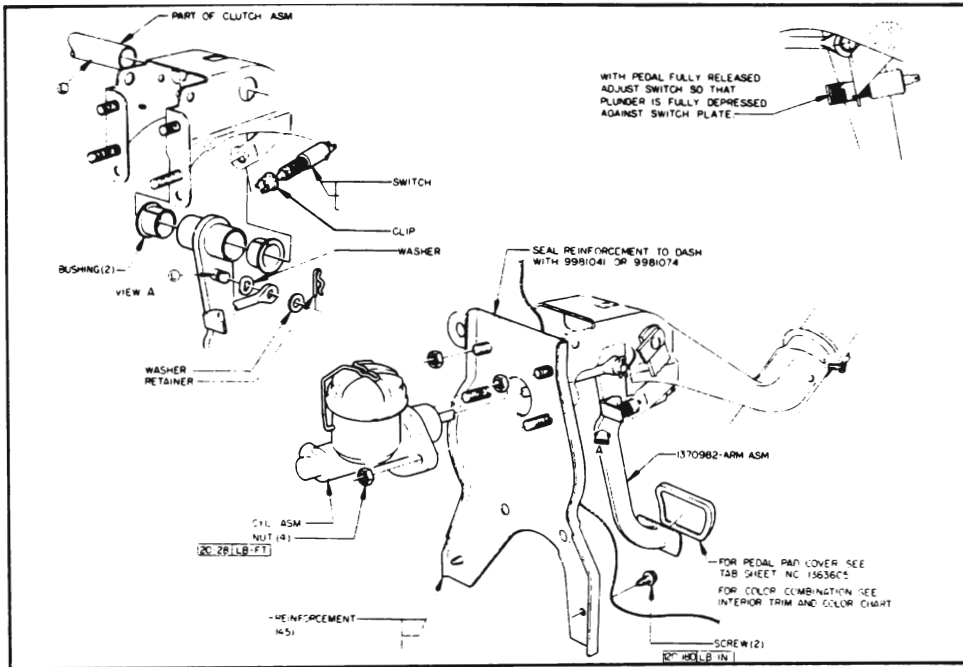

**Figure 9-7—Standard Brake Pedal and Master Cylinder Installation (Synchromesh)**

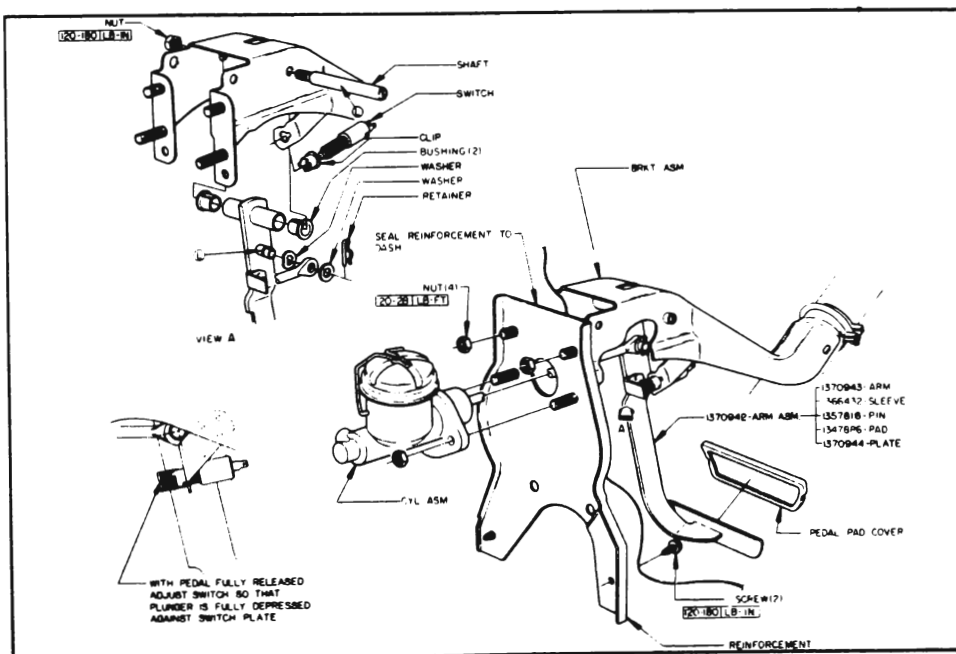

**Figure 9-8—Standard Brake Pedal and Master Cylinder Installation (Automatic)**

#### d. Self Adjusting Brake

The self adjusting brake mechanism consists of an actuator, actuator pivot, actuator return spring, override spring and an actuating link. See Figure 9-13. The self-adjusting brake mechanism is mounted on the secondary shoes and operates only when the brakes are applied while the car is moving in a rearward direction and only when the secondary shoe moves a predetermined distance toward the brake drum.

When the car is moved in a rearward direction and the brakes are applied, friction between the primary shoe and the drum forces the primary shoe against the anchor pin. Hydraulic pressure in the wheel cylinder forces the upper end of the secondary shoe away from the anchor pin, the upper end of the actuator is prevented from moving by the actuating link. This will cause the actuator to pivot on the secondary shoe forcing the actuator lever against the adjusting screw star wheel. If the brake linings are worn enough to allow the secondary shoe to move the predetermined distance, the actuator will turn the adjusting screw one tooth. If the secondary shoe does not move the predetermined distance, movement of the actuator will not be great enough to rotate the adjusting screw.

When the brakes are released, the actuator return spring will return the actuator into adjusting position on the adjusting screw.

### 9-3 OPERATION OF HYDRAULIC SERVICE BRAKES

**NOTE:** See Sections 9-D and 9-E for power brakes.

When the brakes are fully released, the master cylinder piston is held against the stop plate and the primary cup is held just clear of the compensating port by the master cylinder spring, which also holds the check valve against

its seat on the valve seat washer. The pressure chamber is filled with fluid at atmospheric pressure due to the open compensating port and reservoir rubber diaphragm. All pipes and wheel cylinders are filled with fluid under a "static" pressure of 8-16 pounds per square inch, which helps to hold the lips of the wheel cylinder cups in firm contact with cylinder walls to prevent loss of fluid or entrance of air. See Figure 9-9, View A.

When the brake pedal is depressed to apply the brakes, the push rod forces the master cylinder piston and primary cup forward. As this movement starts, the lip of the primary cup covers the compensating port to prevent escape of fluid into the reservoir. Continued movement of the piston builds pressure in the pressure chamber and fluid is then forced through holes in the check valve and out into the pipes leading to all wheel cylinders. Fluid forced into the wheel cylinders between the pistons and cups causes the pistons and connecting links to move outward and force the brake shoes into contact with the drums. See Figure 9-9, View B.

Movement of all brake shoes into contact with drums is accomplished with very light pedal pressure. Since pressure is equal in all parts of the hydraulic system, effective braking pressure cannot be applied to any one drum until all of the shoes are in contact with their respective drums; therefore the system is self-equalizing. After all shoes are contacting the drums, further force on brake pedal builds up additional pressure in the hydraulic system, thereby increasing the pressure of shoes against drums.

On rapid stops some car weight is transferred from the rear to the front wheels, consequently greater braking power is required at front wheels in order to equalize the braking effect at front and rear wheels. Greater force is applied

to front brake shoes by using larger wheel cylinders, so that distribution of braking power is approximately 56% at front wheels and 44% at rear wheels.

When the brake pedal is released, the master cylinder spring forces the pedal back until the push rod contacts the stop plate in master cylinder. This spring also forces the piston and primary cup to follow the push rod and presses the check valve firmly against its seat.

At start of a fast release the piston moves faster than fluid can follow it in returning from the pipes and wheel cylinders, therefore, a partial vacuum is momentarily created in the pressure chamber. Fluid supplied through the breather port is then drawn through the bleeder holes in piston head and past the primary cup to keep the pressure chamber filled. See Figure 9-9, View C.

As pressure drops in master cylinder, the shoe springs retract all brake shoes and the connecting links push the wheel cylinder pistons inward, forcing fluid back to master cylinder. Pressure of returning fluid causes a rubber disc to close all holes in the check valve and forces the check valve off its seat against the tension of master cylinder spring; fluid then flows around the check valve into the pressure chamber. With the piston bearing against the stop plate and the lip of the primary cup just clear of the compensating port, excess fluid which entered through the bleeder holes, or was created by expansion due to increased temperature, now returns to reservoir through the uncovered compensating port. See Figure 9-9, View D. When pressure in wheel cylinders and pipes becomes slightly less than the tension of master cylinder spring, the check valve returns to its seat on head nut to hold 8 to 16 pounds per square inch of "static" pressure in the pipes and cylinders.



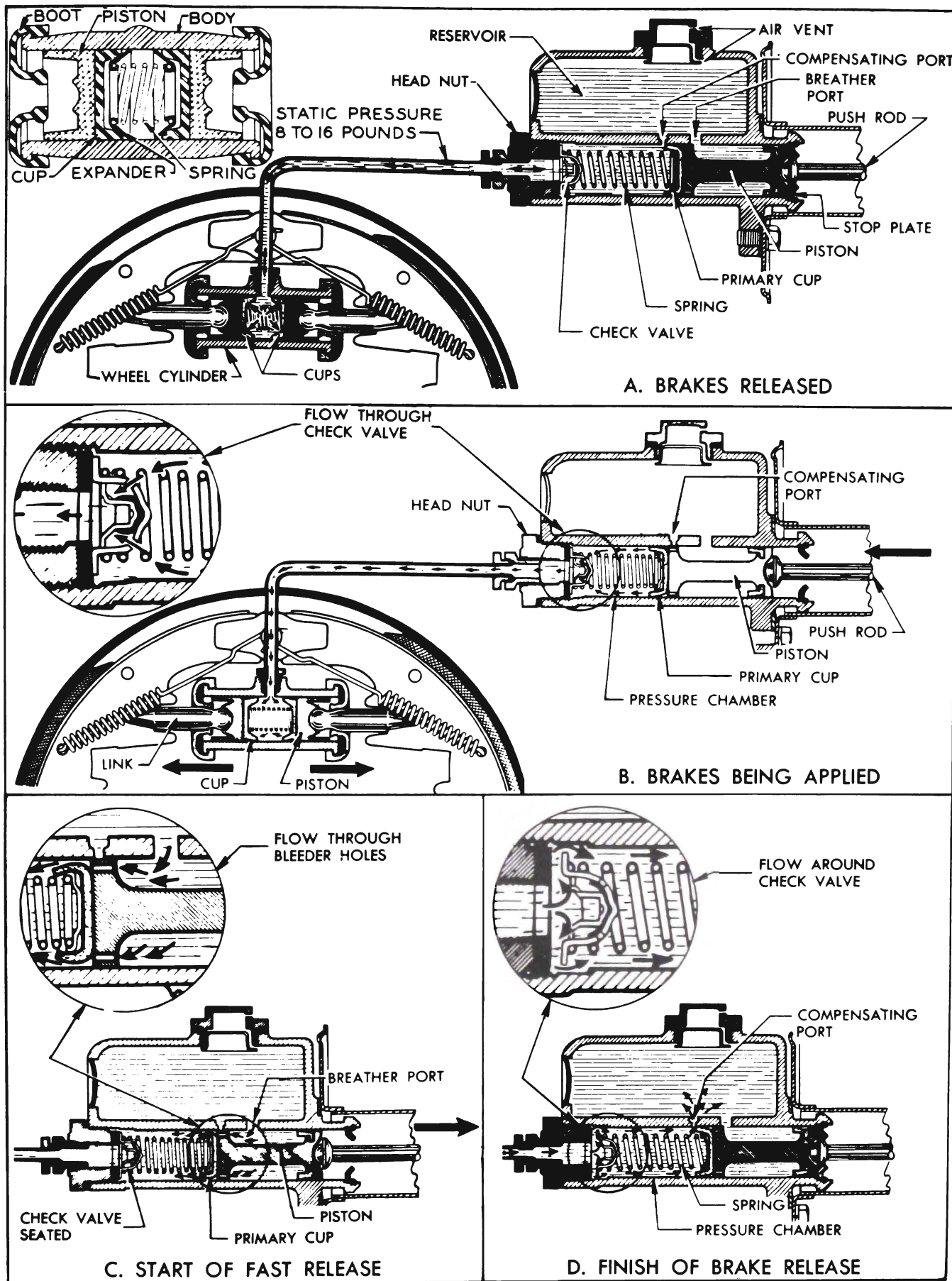

Figure 9-9—Operation of Brake Hydraulic System