

SECTION 6-C

PROPELLER SHAFT, 45, 46, 48, & 49000 SERIES

CONTENTS OF SECTION 6-C

Paragraph	Subject	Page	Paragraph	Subject	Page
6-21	Description of Propeller Shaft— 45, 46, 48000	6-42	6-27	Installation of Propeller Shaft	6-54
6-22	Description of Propeller Shaft— 49000	6-46	6-28	Adjustment of Rear Universal Joint Angle—45, 46, 48000	6-55
6-23	Propeller Shaft Trouble Diagnosis	6-46	6-29	Adjustment of Rear Universal Joint Angle—49000	6-58
6-24	Removal of Propeller Shaft	6-48	6-30	Propeller Shaft Balancing Procedure	6-58
6-25	Disassembly of Propeller Shaft	6-49			
6-26	Assembly of Propeller Shaft	6-51			

6-21 DESCRIPTION OF PROPELLER SHAFT—45, 46, 48000

The propeller shaft assembly consists of a front propeller shaft, a rear propeller shaft, a standard universal joint at each end, and a double constant velocity type universal joint in the center. See Figure 6-87. A center support bearing attaches the rear end of the front propeller shaft to a center bearing support assembly which is mounted on a cross member between the right and left sides of the perimeter frame. A

splined front yoke on the front end of the rear propeller shaft extends into a splined coupling in the rear end of the front propeller shaft. This slip spline permits the slight lengthening and shortening of the propeller shaft required by the up and down movement of the rear axle assembly. See Figure 6-88.

The constant velocity universal joint is composed of two single joints connected with a special link yoke. A center ball and socket between the joints maintains the relative position of the two units. See Figure 6-88. This

center ball causes each of the two joints to operate through exactly one half of the complete angle between the front and rear propeller shafts. Because the two joint angles are the same, even though the usual universal joint fluctuation is present within the unit, the acceleration of the front joint is always neutralized by the deceleration of the rear joint, or vice versa. The end result is, the front and rear propeller shafts always turn at a constant velocity.

The center support bearing consists of a sealed bearing, the inner race of which is held

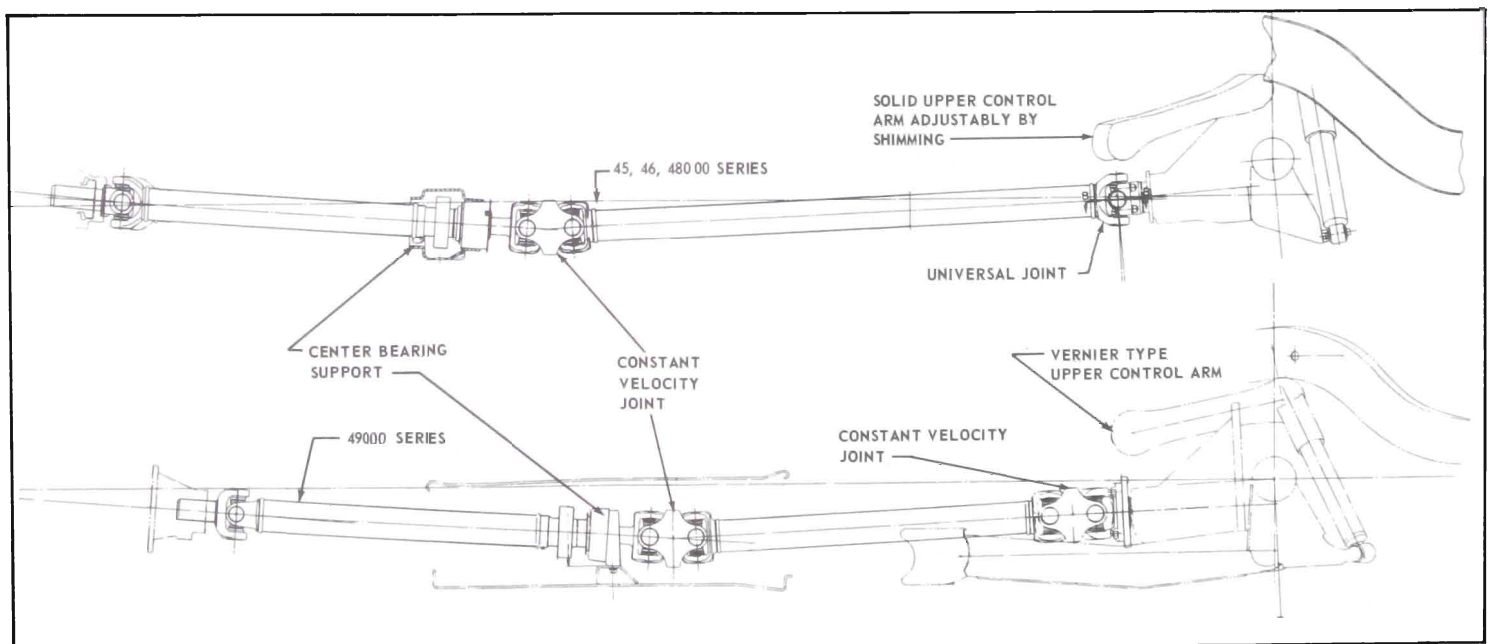

Figure 6-87—Propeller Shaft and Rear Axle Assembly

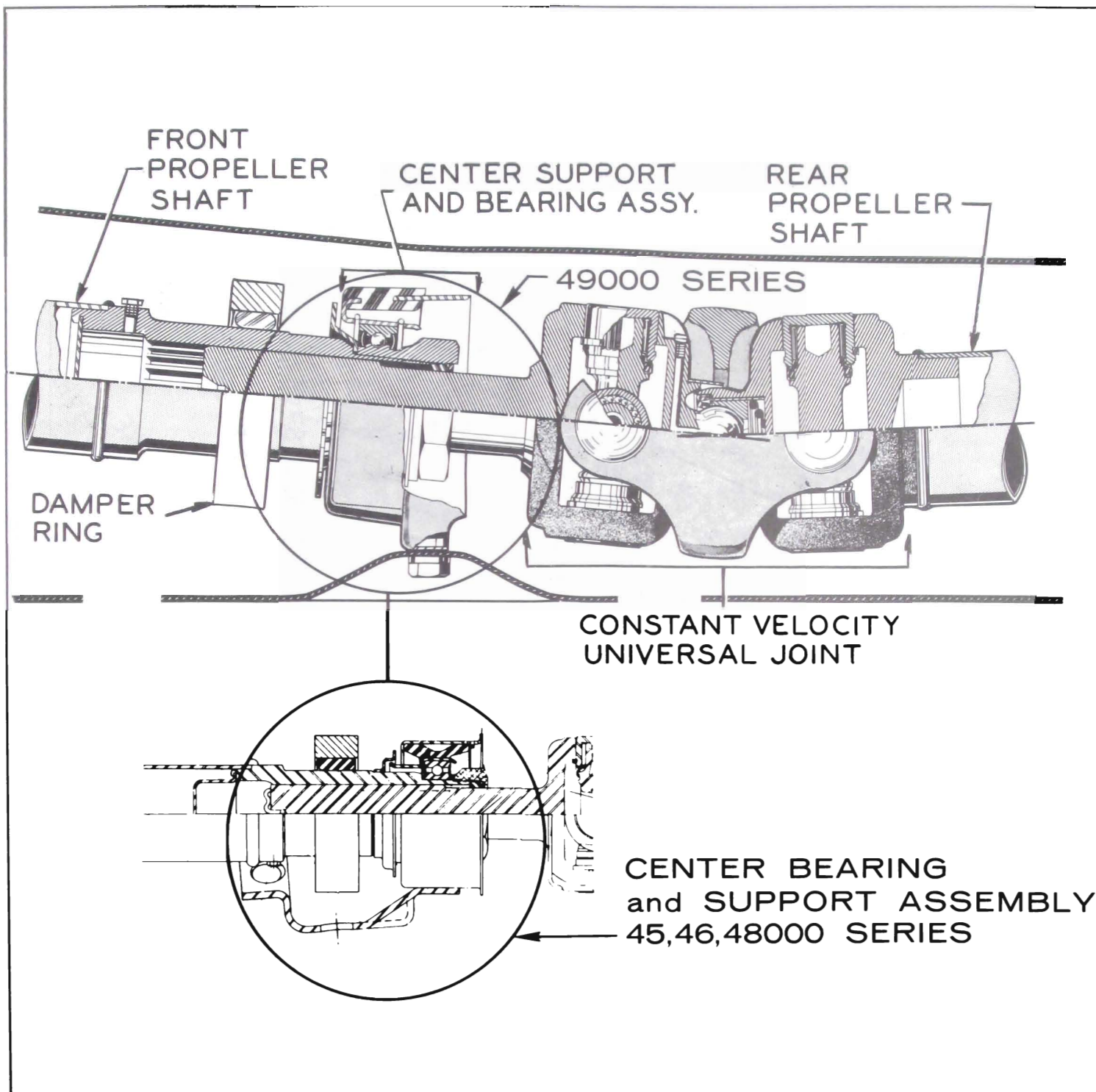

Figure 6-88—Center Support, Bearing and Constant Velocity Joint

against a shoulder at the rear end of the front propeller shaft by a locknut. The center bearing outer race sets in a metal retainer which has a rubber support cushion bonded to it. The rubber cushion in turn is held in a round open cup by a flat washer and a wire snap ring. The locknut which

retains the center bearing in place also prevents the slip joint from separating. The seal which retains the lubricant in the slip spline is located inside the locknut. See Figures 6-88 and 89.

The propeller shaft assembly requires very little periodic serv-

ice. The center support bearing is lubricated for life and requires no additional lubrication. The universal joints are all lubricated for life and cannot be lubricated while in the car. If a joint becomes worn or noisy, a service kit must be installed which consists of a spider complete with

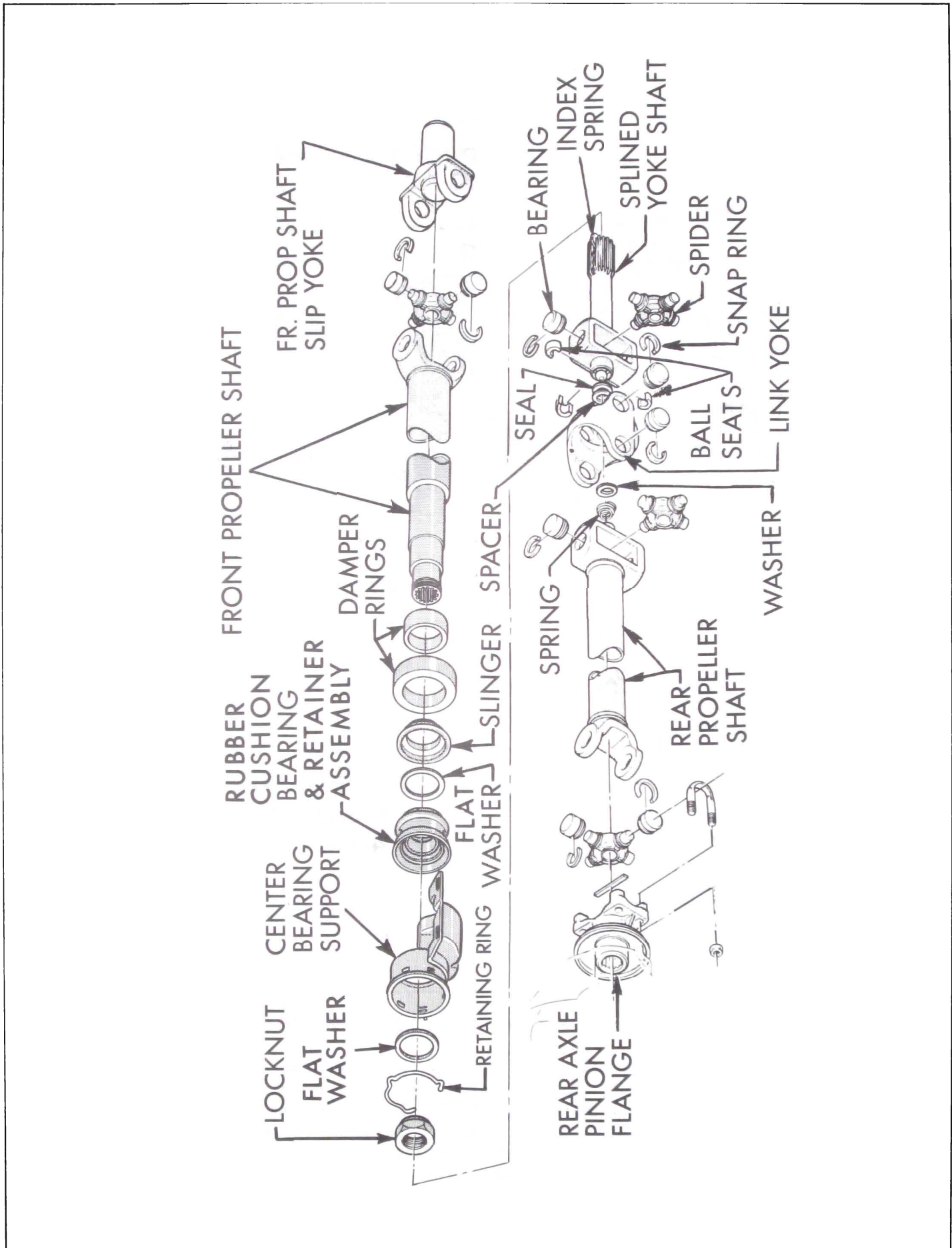

Figure 6-89—Exploded View—Propeller Shaft—45, 46, 48000 Series

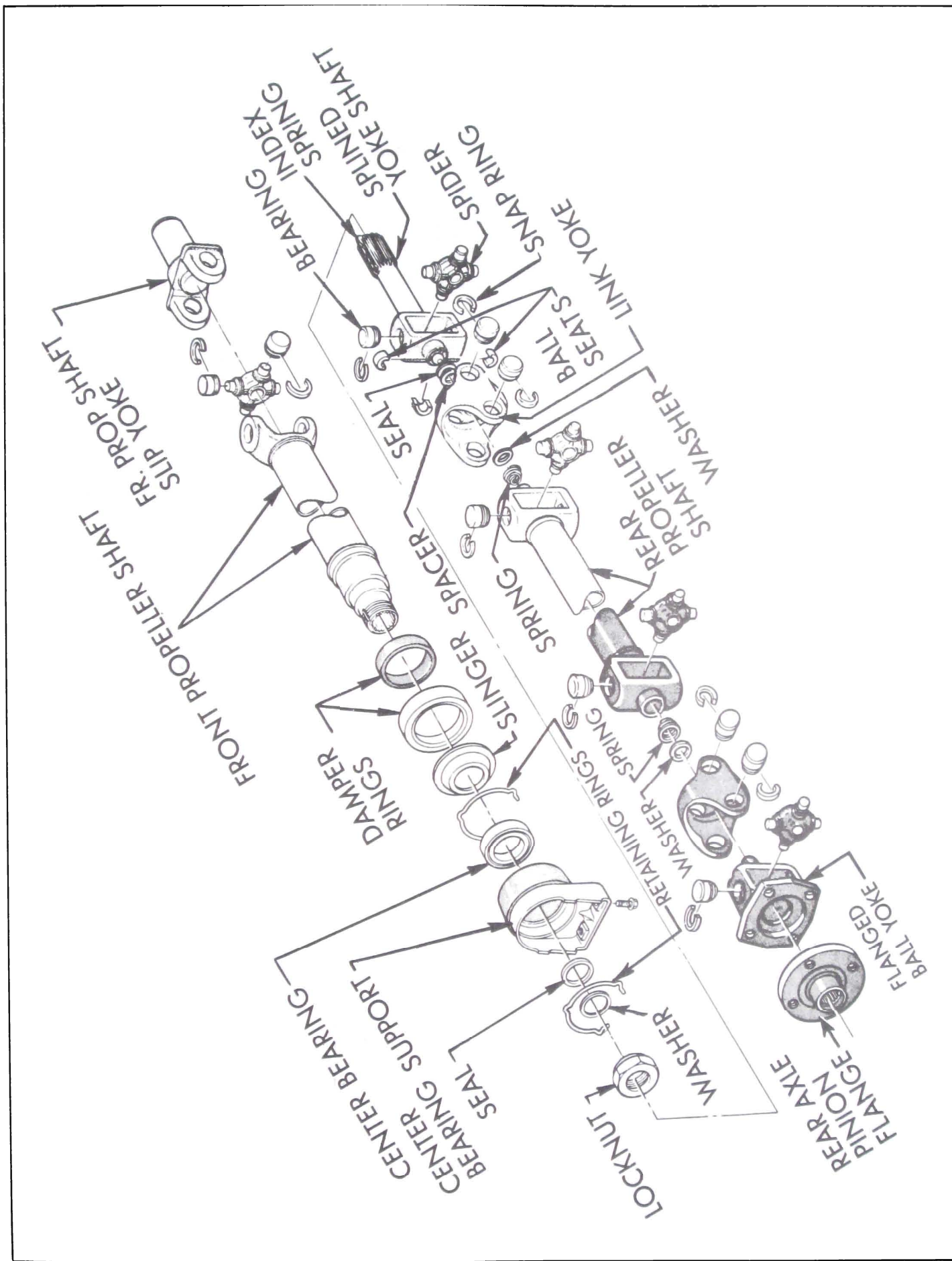

Figure 6-90—Exploded View—Propeller Shaft—49000 Series

bearing assemblies and snap rings.

Front and rear propeller shafts will not be available separately, but only as a complete propeller shaft assembly; this is because the complete assembly must be given a careful rotating balance and this type of balancing equipment is not available in the field.

If any part of the propeller shaft requires repair, it is necessary to remove the complete propeller shaft assembly from the car. The assembly must be handled very carefully to avoid jamming or bending any of the parts.

If the car is to be undercoated, care must be taken to keep the propeller shaft completely free of undercoating material. Undercoating or any other material would upset the balance and might cause a serious vibration.

The center ball stud and seat should be lubricated every 6,000

miles with Multi-Purpose Grease EP No. 1 Grade. Refer to paragraph 1-3.

The slip spline should also be lubricated with Multi-Purpose Grease EP No. 1 Grade every 12,000 miles, or after disconnecting the slip joint for any reason. To lubricate the spline, remove the plug and install a grease fitting. When grease appears at the slip joint nut, remove the fitting and reinstall the plug. The plug must be in place as lubricant would be thrown out through the fitting by centrifugal force at high speeds. Refer to paragraph 1-4.

6-22 DESCRIPTION OF PROPELLER SHAFT—49000

The propeller shaft used on 49000 Series utilizes a front universal joint and two constant velocity

joints, one at the center of the shaft and the other at the rear. All components other than the center bearing support and the rear constant velocity joint are similar in appearance and function to the 45, 46 and 48000 propeller shaft. See Figure 6-90.

The center and rear constant velocity joint ball stud seats should be lubricated every 6,000 miles with Multi-Purpose Grease EP No. 1 Grade. The center slip spline should also be lubricated every 12,000 miles with Multi-Purpose Grease EP No. 1 Grade.

Removal, installation and overhaul procedures are similar to the 45, 46, 48000 propeller shafts with the exception of the additional rear constant velocity joint and the center bearing. The CV joint assembly is disassembled and reassembled in the same manner as the center constant velocity joint.

6-23 PROPELLER SHAFT TROUBLE DIAGNOSIS

COMPLAINT	POSSIBLE CAUSE	REMEDY
Shudder on acceleration, low speed.	Loose or missing bolts at center bearing support to frame cross member.	Tighten bolts.
	Improperly adjusted rear joint angle.	Check and adjust using Kent-Moore alignment gauge.
	Incorrectly set front joint angle.	Shim under transmission support mount to decrease front joint angle.
	Incorrect plan view joint angles.	Use Kent-Moore alignment gauge cable and weighted strings from engine pulleys and propeller shaft to align shaft in plan view.
	Improper yoke phasing.	Check for correct yoke phasing and correct if necessary. See Figure 6-110.

6-23 PROPELLER SHAFT TROUBLE DIAGNOSIS (Cont'd)

COMPLAINT	POSSIBLE CAUSE	REMEDY
Roughness or vibration, any speed.	<p>Cut center bearing support rubber.</p> <p>Improper yoke phasing.</p> <p>Bent shaft.</p> <p>Dented shaft.</p> <p>Improperly aligned support.</p> <p>Tight universal joints.</p> <p>Worn universal joints.</p> <p>U-joint retainer bent against bearing cup.</p> <p>Undercoating on shaft.</p> <p>Incorrect U-bolt torque.</p> <p>Burrs or gouges on companion flange snap ring location surfaces.</p> <p>Incorrect rear joint angle (usually too large an angle).</p> <p>Tire unbalance.</p> <p>Shaft or companion flange unbalance combination.</p>	<p>Replace.</p> <p>Correct as above.</p> <p>Replace.</p> <p>Replace - On 49000 check to see if sufficient clearance exists between rear frame tunnel and propeller shaft if car is raised on a frame hoist. Grind out frame for sufficient clearance if necessary.</p> <p>Align or check for proper installation of mountings.</p> <p>Impact yokes with hammer to free up. Replace joint if unable to free up or if joint feels rough when rotated by hand.</p> <p>Replace.</p> <p>Replace.</p> <p>Clean up shaft.</p> <p>Check and correct - (15-18 ft. lbs.)</p> <p>Attempt to clean up flange. Replace companion flange if necessary.</p> <p>Check and adjust using Kent-Moore alignment gauge.</p> <p>Balance wheel and tire assembly or replace from known good car.</p> <ol style="list-style-type: none"> 1. Check for missing balance weights. 2. Remove and reassemble shaft to companion flange 180° from initial location. 3. Remove and replace companion flange at rear axle pinion 180° from initial location. 4. Rebalance.

6-23 PROPELLER SHAFT TROUBLE DIAGNOSIS (Cont'd)

COMPLAINT	POSSIBLE CAUSE	REMEDY
Roughness on heavy acceleration (short duration).	CV joint ball seats worn. Seat spring set or broken.	Replace with ball seat repair kit. Replace with ball seat repair kit.
Roughness usually at low speeds, light load, 15-35 MPH.	Improperly adjusted joint angles.	Check and adjust rear joint angle, decrease front angle by shimming transmission support.
Whine or whistle.	Center support bearing.	Place car on hoist with rear wheels free to rotate and diagnose for source of noise. Replace center support bearing if found to be noisy.
Squeak.	Lack of lubricant or worn CV joint centering ball.	1. Lube. 2. Replace with ball socket kit if lube does not correct.
Knock or click.	Joint hitting frame tunnel, 49000 only. Worn CV joint centering ball. Loose upper or lower control arm bushing bolts. Broken or cut center bearing support rubber. Stones - gravel in frame tunnel, 49000 only.	Shim up or replace center bearing mount. Replace with splined yoke or ball seat replacement kit. Tighten bolts. Replace center bearing support. Remove stones and gravel.
Scraping noise.	Parking brake cable interference in frame tunnel, 49000 only. Slinger on companion flange rubbing on rear axle carrier.	Correctly route cable. Straighten out slinger to remove interference.
Boom period 30 - 40 MPH carrying heavyloads or hauling trailer.	Excessive rear joint angle.	Reduce angle.

6-24 REMOVAL OF PROPELLER SHAFT

Whenever service is required, the propeller shaft must be removed from the car as a complete assembly. During handling out of the car, the assembly must be

supported in a straight line as nearly as possible to avoid jamming or bending any of the parts.

1. Remove four center bearing attaching bolts (two bolts on 49000).
2. At rear pinion flange, remove

U-bolt clamps from rear universal joint. (On 49000, remove four rear CV joint to pinion flange bolts.) Mark both flange and shaft to assemble in same position. **CAUTION: If rear universal joint bearings are not retained on the spider by a connecting strap, use**

tape or wire to secure bearings.

3. Support rear end of propeller shaft to avoid damage to constant velocity universal joint and slide complete assembly rearward until front yoke slips from transmission shaft splines.

4. Protect the oil seal surface on the front slip yoke by taping or wiring a cloth over the complete front universal joint.

5. Slide complete propeller shaft assembly rearward through frame tunnel (49000 only). Do not bend constant velocity joint to its extreme angle at any time.

6-25 DISASSEMBLY OF PROPELLER SHAFT ASSEMBLY

For ease in handling, and to help prevent damage to the constant velocity universal joint, the front and rear propeller shafts should be separated at the slip joint before any service operations are attempted. **CAUTION: Never clamp propeller shaft tubing in a vise as the tube is easily dented. Always clamp on one of the yokes. Be careful not to damage the front propeller shaft slip yoke sealing surface. Any nicks can damage the bushing or cut the seal.**

a. Disassembly of Slip Joint

1. Loosen locknut until free of threads and slide locknut and seal against the constant velocity joint.
2. Slide the rear propeller shaft from the front.

b. Removal & Disassembly of Center Bearing Assembly

1. Mount propeller shaft assembly in a vise by the yoke to keep it from turning while using the puller.
2. Place the smaller O.D. end of adapter J-2241-8 (Differential

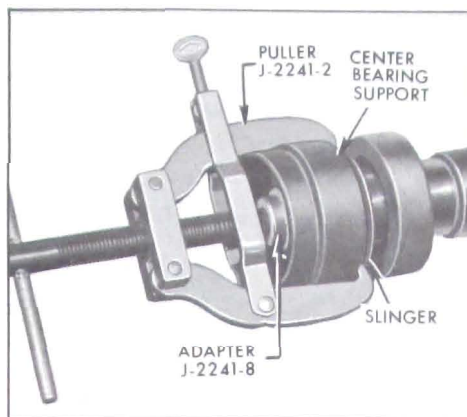

Figure 6-91—Removing Center Support and Bearing—49000 Series

side carrier bearing puller adapter, 1955 and previous) into the splines of the propeller shaft. Position Differential Side Bearing Puller J-2241-2 as shown in Figures 6-91 and 6-91b. Pull the center support and bearing assembly from the propeller shaft. Leave the slinger (shield) in position on the shaft.

3. Remove center bearing from support as follows:

- a. On 45, 46, 48000 Series, remove snap ring and flat washer. Remove center bearing assembly with assistance of Remover J-7273-22 and Handle J-7013-1 (Flight Pitch tools).

NOTE: On 45, 46, 48000 Series, replacement bearing must be serviced as an assembly including bearing rubber cushion and inner

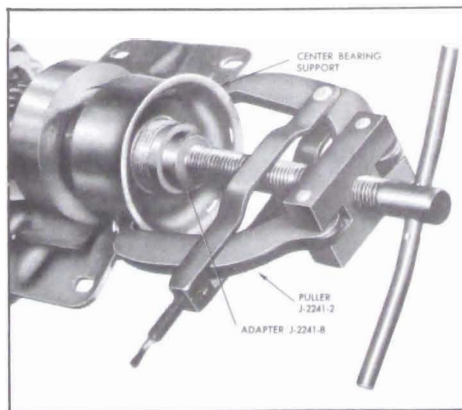

Figure 6-91b—Removing Center Support and Bearing—45, 46, 48000 Series

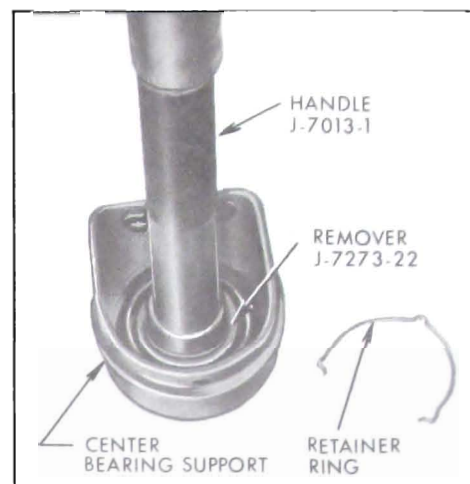

Figure 6-92—Removing Center Bearing From Support

retainer. Order from Parts Department under Group 5.441.

b. On 49000, remove retainer rings from bearing assembly and remove center bearing with assistance of Remover J-7273-22 and Handle J-7013-1. See Figure 6-92.

c. Disassembly of Constant Velocity Universal Joint

All yokes must be marked before disassembly for reassembly in their original positions to maintain proper balance. For ease of disassembly remove the bearings from the link yoke first. See Figure 6-93. **NOTE:** On 49000, the following procedure applies

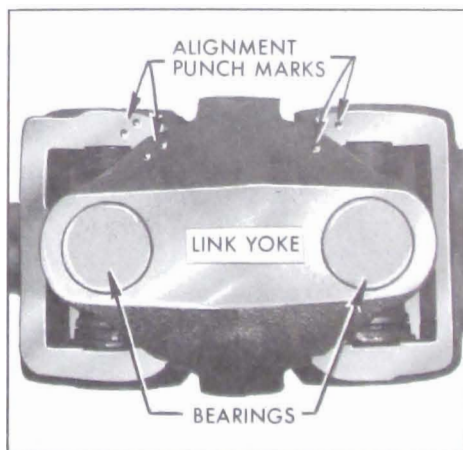

Figure 6-93—Link Yoke Showing Alignment Punch Marks

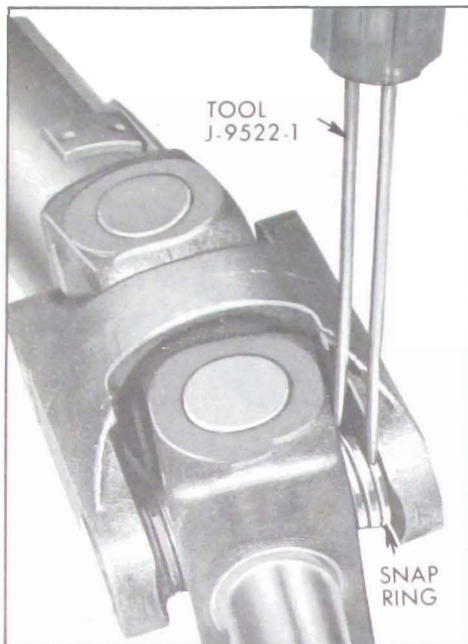

Figure 6-94—Removing Snap Rings From Propeller Shaft

to either center or rear constant velocity joints.

1. Remove snap rings from the bearings. The snap rings are on the inside of the link yoke and can be removed with the assistance of Tool J-9522-1. See Figure 6-94.

2. Set up J-6180-01 Power Ram and J-6207 Hydraulic Pump in

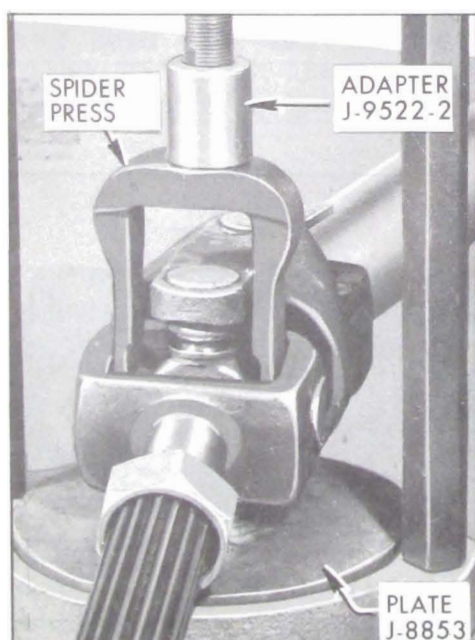

Figure 6-95—Pressing Out Bearing

preparation for removing the propeller shaft bearings. With this use Axle Bearing and Retainer Replacer J-8853 as a base plate. Attach Adapter J-9522-2 onto the ram screw. See Figure 6-95.

3. Position propeller shaft constant velocity joint into the fixture as set up in Step 2 with the link yoke bearing over the hole in J-8853 Replacer Plate. Install Spider Press J-9522-3 on spider. See Figure 6-95. The notches in the spider press are offset so that this press can be positioned on the spider without interference from the link yoke casting.

With tools in position, actuate the pump and force the spider against the lower bearing, pushing the bearing as far out of the yoke and through the hole in Tool J-8853 as possible.

4. Release the pump and remove the propeller shaft. Install Spacer J-9522-5 over the spider journal at the space provided with the bearing forced partially through the link yoke. See Figure 6-96. Reposition propeller shaft in fixture as before and force with the added assistance of the Spacer.

5. Release the pump and the propeller shaft. Install Guide J-9522-8 through the bearing hole in the link yoke and over the journal end of the spider. See Figure 6-97. This guide assures alignment of the spider while removing the opposite bearing.

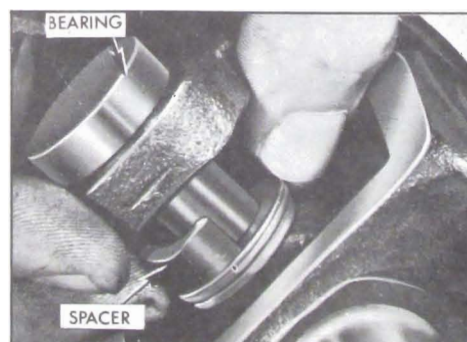

Figure 6-96—Installing Spacer

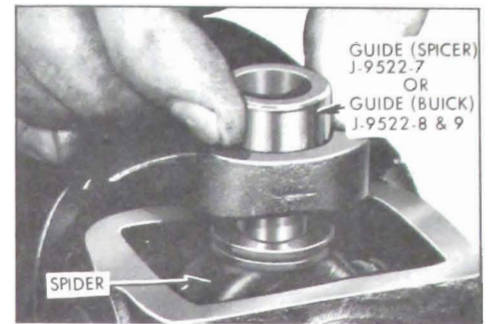

Figure 6-97—Installing Guide

6. Install Spacer J-9522-5 adjacent to the bearing as in Step 4 and remove the bearing. See Figure 6-98.

7. Repeat Steps 3, 4, 5 and 6 to remove other bearings until the propeller shaft is disassembled to a point desired or until the spider can be slipped out of the link yoke.

d. Disassembly of Ball Stud Seat

1. Position the propeller shaft yoke in a vise so that the ball stud seat is accessible for removal.

2. With a screwdriver pry out the seal, remove seal washer, ball seats, seat washer, and ball seat spring.

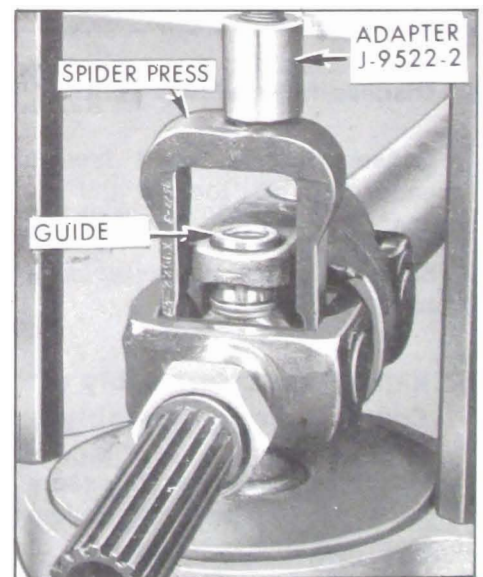

Figure 6-98—Removing Bearing with Guide and Spacer in Place

e. Disassembly of the Front and Rear Universal Joints

CAUTION: Do not damage front propeller shaft slip yoke sealing surface. Any nicks can damage bushing or cut seal.

1. Remove snap rings from the bearings. The snap rings are on the inside of the yoke and can be removed with the aid of Tool J-9522-1. See Figure 6-94.

2. Set up J-6180-01 Power Ram and J-6207 Hydraulic Pump in preparation for removing the propeller shaft bearings. With this use Axle Bearing and Retainer Replacer J-8853 as a base plate. Attach Adapter J-9522-2 onto the ram screw. See Figure 6-99.

3. Position the propeller shaft universal joint into the fixture as set up in Step 2 with a bearing over the hole in Replacer J-8853. Install Spider Press J-9522-3 on spider. See Figure 6-99.

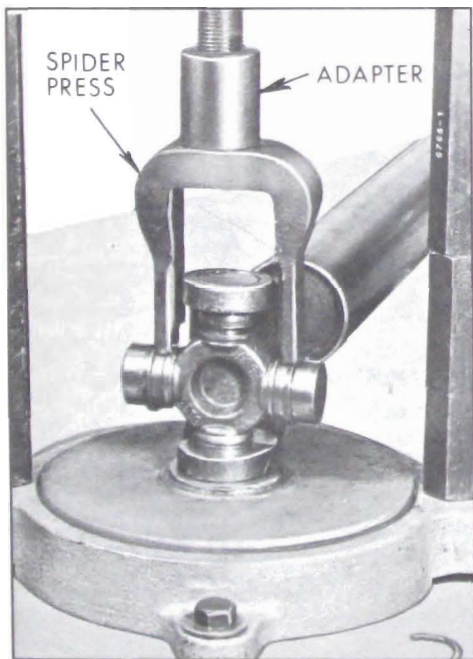

Figure 6-99—Pressing Out U-Joint Bearing

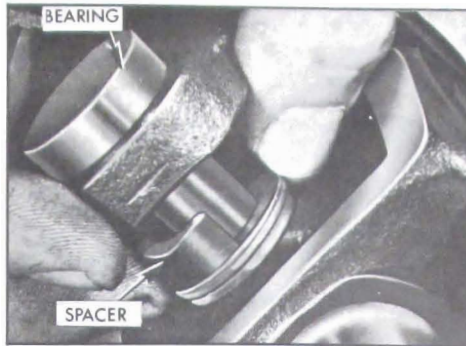

Figure 6-100—Installing Spacer

With tools in position actuate the pump and force the spider against the lower bearing, pushing the bearing as far out of the universal joint and through the hole in Tool J-8853 as possible.

4. Release the pump and remove the propeller shaft. Install Spacer J-9522-5 over the spider journal at the space provided with bearing forced partially through the yoke. See Figure 6-100. Reposition the propeller shaft in the fixture as before and force the bearing completely out of the yoke with the added assistance of the Spacer.

5. Release pump and propeller shaft. Install Guide J-9522-8 through the bearing hole in the yoke and over the journal end of the spider. See Figure 6-101. This guide assures alignment of the spider while removing the opposite bearing.

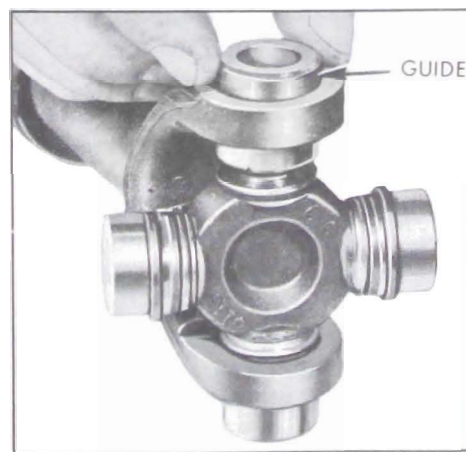

Figure 6-101—Installing Guide on U-Joint

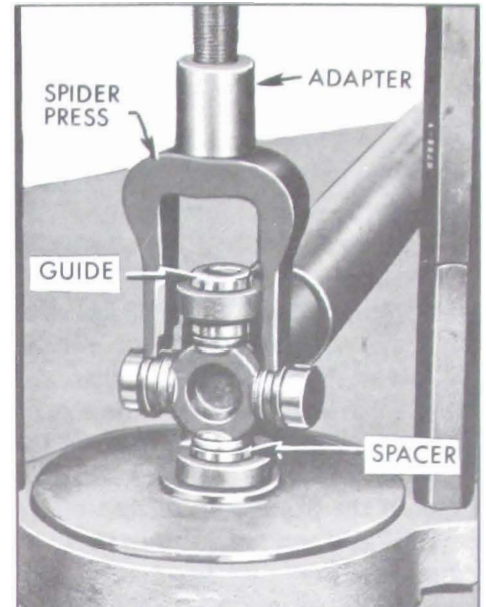

Figure 6-102—Removing Bearing with Guide and Spacer in Place

6. Install Spacer J-9522-5 adjacent to the bearing as in Step 4 and remove the bearing. See Figure 6-102.

7. Repeat Steps 3, 4, 5 and 6 to remove other bearings until the propeller shaft is disassembled to a point desired.

6-26 ASSEMBLY OF PROPELLER SHAFT

a. Assembly of Front and Rear Universal Joints

When inspection indicates any worn or damaged universal joint parts, always install a complete universal joint repair kit. Repair kits are listed in the Buick Parts Book under Gr. 5.442 and include a spider, four bearings, and four snap rings.

1. Position the new spider inside the yoke; it may face either direction. Make certain that the spider dust shields are not damaged upon installation.

2. Make certain that the bearings have a full set of rollers, are packed with lubricant, and that the seals are in position. Multi-Purpose Universal Joint bearing

grease No. 2 grade should be added to bearings if they are dry, although new bearings are normally pre-lubricated as received from the source.

Place the assembly in position with Power Ram J-6180 and Pump J-6207 as shown in Figure 6-103. Position the bearing straight over the hole in the yoke. Carefully pull up the spider so that the spider journal enters the loose bearing. With the pump, force the bearing into the yoke continuing to hold the spider up in this bearing. Failure to do this could cause the bearing needles to become dislodged if the journal is engaged incorrectly.

When the bearing is correctly positioned in the yoke, turn the assembly over. Again place the bearing over the hole in the yoke. Carefully slide the spider partially out of the previously seated bearing and start it carefully into the bearing being installed. This is to prevent the needles from the bearing from burring the edge of the spider journal if forced over this journal other than straight. Even slight burring of the journal can cause premature failure.

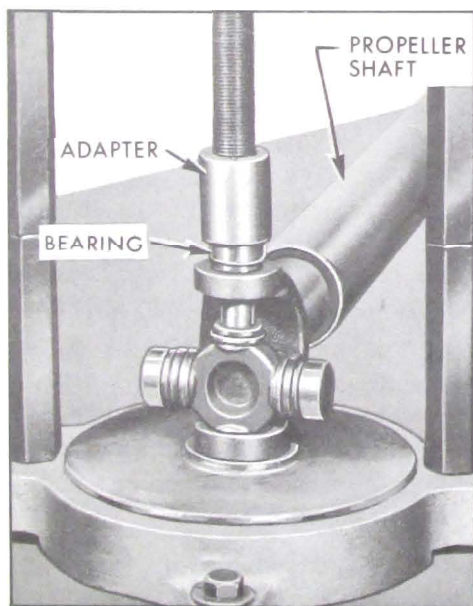

Figure 6-103—Pressing Bearing Into Place

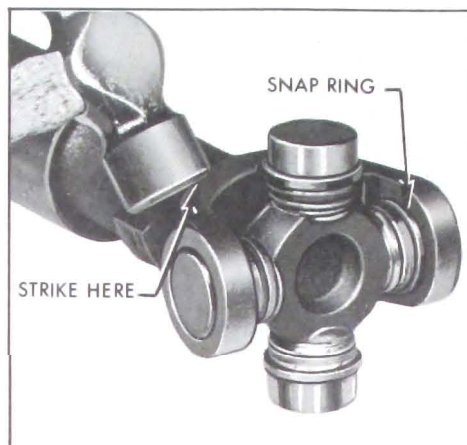

Figure 6-104—Seating U-Joint Snap Rings

While pressing bearings into position, move the spider back and forth to make certain that the spider journals engage the bearings squarely to avoid damage and binding. If binding exists, remove the bearings and spider and examine for dislodged rollers or damaged journals.

3. Observing the previous precautions, install the balance of the bearings necessary to complete the assembly, and install snap rings.

4. Strike the yoke with a hammer to fully seat the snap rings against the yoke. Turn the spider to make certain that it is free. See Figure 6-104.

b. Assembly of the Ball Stud Seat

Examine the ball stud and ball stud seats for scores or wear. Worn seats can be replaced by using a replacement kit, Gr. 5.442. Since the ball stud is an integral part of the splined yoke, any scoring of this part requires the replacement of this splined yoke. This assembly is also available in kit form, Gr. 5.442.

1. Clean out the seat cavity thoroughly, then pack with Multi-Purpose Grease EP No. 1 Grade.

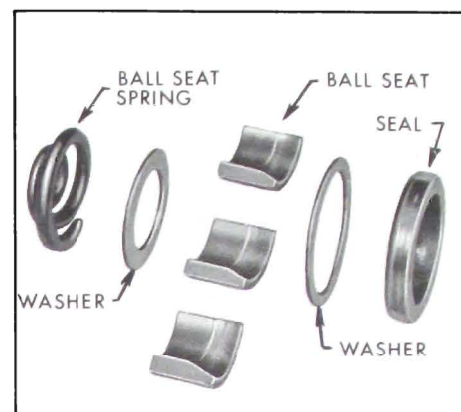

Figure 6-105—Ball Seat Assembly

2. Install spring, small end first. Install seat washer, ball stud seats, and seal washer. See Figure 6-105.

Apply Permatex on the outer diameter of the seal to insure adequate sealing and install seal with its lip towards the seat using Tool J-9732. See Figure 6-106.

3. Stake the seal lightly and evenly in four places. Be careful not to over stake so as to damage or distort the seal.

4. Pack the cavity around the ball stud with Multi-Purpose Grease, EP No. 1 Grade.

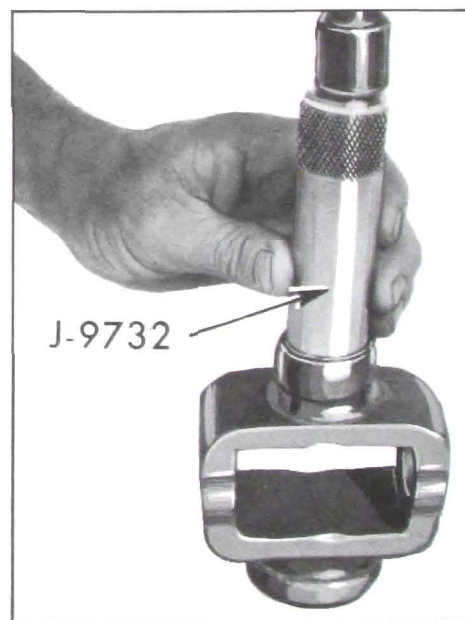

Figure 6-106—Installing Ball Seat Seal

c. Assembly of Constant Velocity Universal Joints

All yokes must be carefully assembled using the marks made before disassembly to assure balance maintenance of the complete propeller shaft assembly.

When inspection indicates any worn or damaged CV Universal Joint parts, always install a complete repair kit. Repair kits are listed in the Buick Parts Book under Gr. 5.442 and include a spider, 4 bearings and 4 snap rings.

1. Make certain that the bearings have a full set of rollers, are packed with lubricant, and that the seals are in position. Multi-Purpose Universal Joint bearing grease, No. 2 grade should be added to bearings if they are dry, although new bearings are normally pre-lubricated as received from the source.

2. For ease of assembly use the following sequence:

a. Connect the link yoke to the rear propeller shaft as outlined in Step 3 below.

b. Insert a new spider without

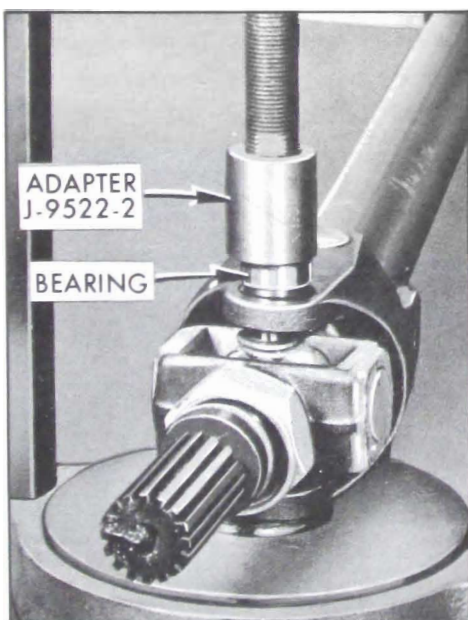

Figure 6-107—Pressing Bearing Into Position

bearings into the splined shaft yoke.

c. Position the ball stud into the ball stud seat while working the spider journals into the holes in the link yoke. Make certain that the spider dust shields are not damaged upon installation.

3. Place the assembly in position with Power Ram J-6180 and Pump J-6207 as shown in Figure 6-107.

Position the bearing straight over the hole in the yoke. Carefully pull up the spider so that the spider journal enters the loose bearing. With the pump, force the bearing into the yoke, continuing to hold the spider up in this bearing. Failure to do this could cause the bearing needles to become dislodged if engaged incorrectly.

When the bearing is correctly positioned in the yoke, turn the assembly over. Again place the bearing over the hole in the yoke. Carefully slide the spider partially out of the previously seated bearing and start it carefully into the bearing being installed. This is to prevent the needles from the bearing from burring the edge of the spider journal if forced over journal other than straight. Even slight burring of the journal can cause premature failure.

While pressing bearings into position, move the spider back and forth to make certain that the spider journals engage the bearings squarely to avoid damage and binding. If binding exists, remove the bearings and spider and examine for dislodged rollers or damaged journals.

4. Install the balance of the bearings necessary to complete the assembly and install snap rings.

5. Strike the yoke with a hammer to fully seat the snap rings against the yoke. Turn the spider to make certain that it is free. See Figure 6-108.



Figure 6-108—Seating Snap Rings

NOTE: If a new splined yoke assembly was used, the car should be carefully roadtested for possible vibration caused by out-of-balanced propeller shaft. If propeller shaft vibration is encountered see the procedure for balancing this assembly in paragraph 6-30.

d. Installation of Center Bearing

1. On 49000 Series, install new bearing into center bearing support with the aid of Installer J-7013-24 and Handle J-7013-1 (Flight Pitch Tools). See Figure 6-109.

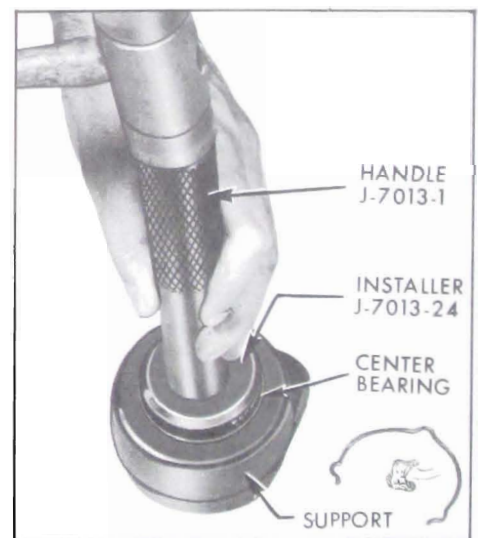

Figure 6-109—Installing Center Bearing into Support

NOTE: On 45, 46, 48000 Series, bearing must be serviced as an assembly including bearing, rubber cushion, and inner retainer. Order replacement from Parts Department under Group 5.441. Install bearing and related parts into cup-shaped support as in preceding step.

2. On 49000 install retainer ring to secure bearing. On 45, 46, 48000 install flat washer and retainer ring.

3. On 49000 make certain that the slinger is in place on the propeller shaft. Install the center bearing support assembly onto the propeller shaft with Installer J-21007. On 45, 46, 48000 make certain that slinger is in place and then install flat washer on shaft. With slinger and washer in place, install center bearing assembly using Installer J-21007.

e. Assembly of Slip Joint

1. Make certain that the locknut, split washer and seal are in place on the smooth part of the spline shaft. Make certain that the index spring wire is in place in the splines.

2. Align the index spring with the missing internal spline in the rear end of the front propeller shaft, and slide the slip joint together. See Figure 6-110 for proper phasing of the propeller shaft.

3. Install the locknut and tighten securely to 65 ft. lbs. using locknut Wrench J-21009.

6-27 INSTALLATION OF PROPELLER SHAFT

The propeller shaft must be supported carefully during handling to avoid jamming or bending any of the parts.

1. Protect the oil seal diameter on the front slip yoke by taping or wiring a cloth over the complete front universal joint.

2. Slide complete propeller shaft assembly forward (through frame tunnel 49000 only).

3. Remove protecting cover from front universal joint. Fill space between lips of transmission seal with wheel bearing grease and apply a thin coat of the same grease to the seal surface of the front universal joint.

4. Slide front universal joint yoke forward over splines of transmission shaft.

5. Compress two loose bearings of rear universal joint toward each other using a 4 inch C-clamp. See Figure 6-111. This allows the bearings to seat in the pinion flange without the snap rings gouging the locating surfaces of the pinion flange while entering.

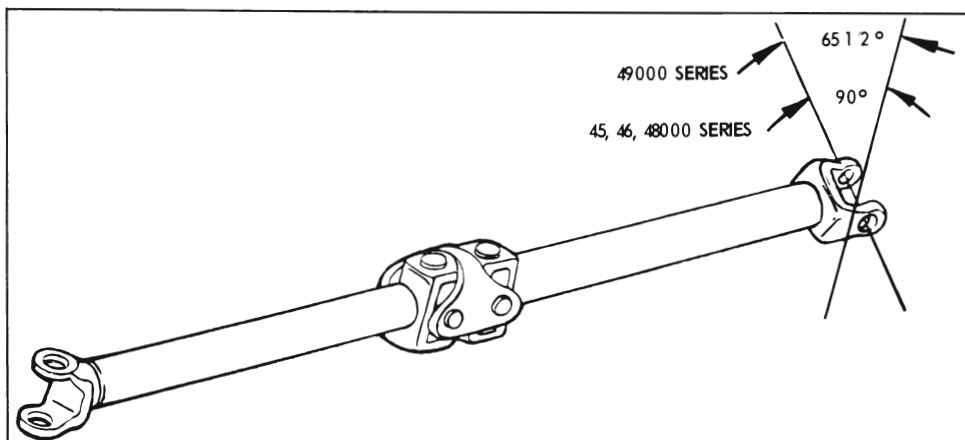

Figure 6-110—Propeller Shaft Phasing

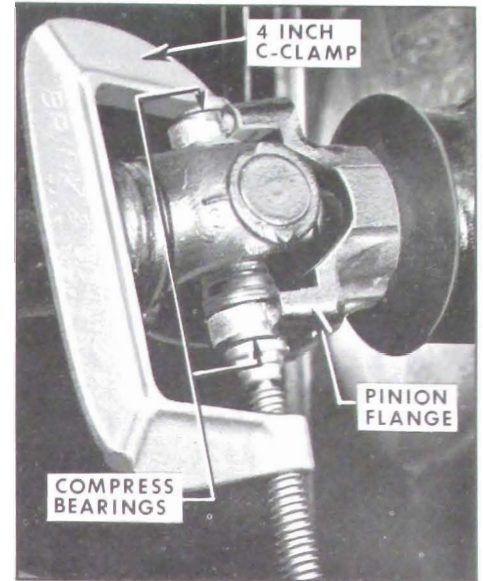

Figure 6-111—Using C-Clamp to Install a Universal Joint

6. Install U-bolt clamps and nuts. Draw nuts up evenly and torque to 15-18 ft. lbs. using a 1/2 inch extension such as J-9113. (On 49000, install four pinion flange bolts and torque evenly to 75-95 ft. lbs.). See Figure 6-112. **CAUTION:** Overtightening U-bolt nuts distorts the bearings, causing a binding on the spider which can cause drive line shudder and also reduce the life of the bearings and spider.

7. Install two bolts in center bearing support. Torque to 15-25

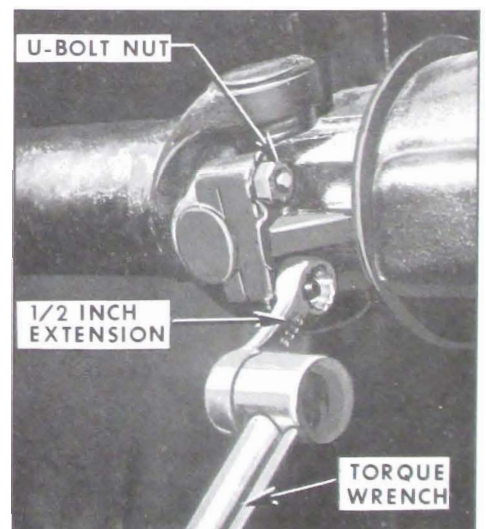

Figure 6-112—Using Extension to Torque U-Bolt Nuts

ft. lbs., 49000 only. On 45, 46, 48000 install four bolts at center bearing support to frame cross member and torque to 17-23 ft. lbs.

NOTE: Before torquing bolts, position propeller shaft rearward to provide approximately 1/2" space between the end of the transmission case extension and the shoulder of the propeller shaft slip yoke.

8. Make certain propeller shaft slip spline and center ball stud seat are fully lubricated with Multi-Purpose Grease EP No. 1 Grade. See paragraphs 1-3 and 1-4 for lubricating procedure.

6-28 ADJUSTMENT OF REAR UNIVERSAL JOINT ANGLE—45, 46, 48000

When torque is transmitted through any ordinary universal joint, the driven yoke fluctuates slightly in speed. In other words, although the driving yoke rotates at a constant speed, the driven yoke speeds-up and slows-down twice per revolution. This fluctuation of the driven yoke is in direct proportion to the angle through which the universal joint is operating; the greater the angle, the greater the fluctuation. Whenever two universal joints are used, this fluctuation effect can be eliminated by staggering the joints so that the two driving yokes are 90° apart providing the two joints are transmitting torque through the same angle.

Therefore, when two universal joints are used, the angles through which they operate must be very nearly the same. This allows the alternate acceleration and deceleration of one joint to be offset by the alternate deceleration and acceleration of the second joint. When the two joints do not run at approximately the same angle, operation is rough

and an objectionable vibration is produced.

In addition, universal joints are designed to operate safely and efficiently within certain angles. If the designed angle is exceeded, the joint may be broken or otherwise damaged.

The front universal joint angle is actually the angle between the engine-transmission centerline and the front propeller shaft. This angle is determined by the design of the body assembly. Since this angle is not liable to change with use, there is normally no need to change this angle. The center constant velocity universal joint, just as the name implies, transmits at a constant velocity regardless of the angle through which it is operating. Therefore, no means is provided or needed for adjusting the constant velocity joint.

However, the rear universal joint angle can vary and must be adjusted. It is adjusted by rotating the rear axle housing; this is accomplished by lengthening or shortening the upper control arms by means of shimming at the frame bracket ends. See Figure 6-113.

If drive line shudder, roughness, vibration, or rumble is experienced, it may be due to incorrect rear universal joint angle and this angle should be checked. Also if there is a severe rear end collision, or if the axle housing

or any control arms are replaced, the rear universal joint angle should be checked and corrected if necessary.

A simple method has been developed for measuring rear universal joint angle using a spring-loaded steel cable stretched between the front of the chassis and the rear axle carrier. When the rear universal joint angle is adjusted correctly, this steel cable will clear the underside of the pinion flange by a definite amount. Therefore, if this single direct measurement is within specified limits, the rear universal joint angle is correct; if this measurement is out of limits, the joint angle is not correct. See Figure 6-114.

Rear universal joint angle is checked using Alignment Set J-8973. The Alignment Height Tubes J-8973-19 in this set are designed to raise the rear of the car slightly above normal trim height. Use of these tubes makes sure that the rear universal joint angle will be checked at a predetermined trim height.

The front end of the cable is equipped with two attaching brackets so that the cable may be used on all series 1965 Buicks. The rear end of the cable has stops attached at various points to allow the cable to be placed in tension on all wheelbase Buicks.

a. Checking Rear Universal Joint Angle

Check rear universal joint angle using the following procedure:

1. Raise car, preferably on a drive-on hoist. Install Alignment Height Tubes J-8973-19 by raising the rear of the body slightly while inserting tubes vertically between frame and axle housing. See Figure 6-114. If the body does not come down firmly on the tubes, add weight in the trunk until the tubes are held tightly.

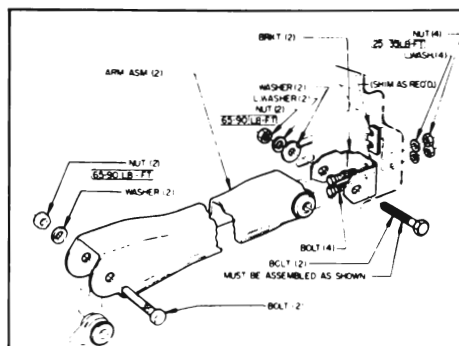

Figure 6-113—Shimming Upper Control Arm for Pinion Angle Adjustment

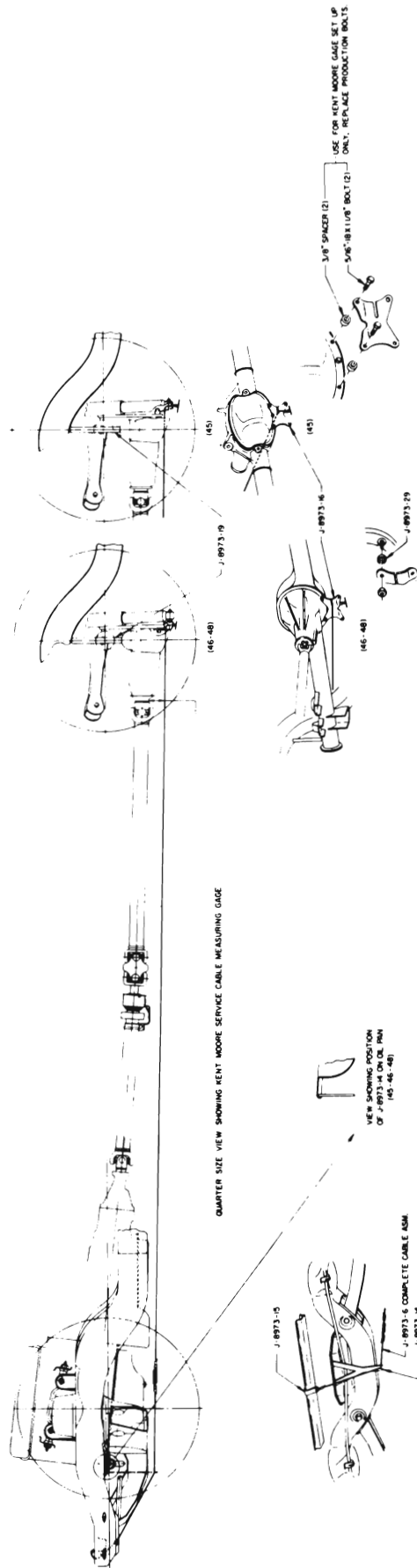

Figure 6-114—Checking Rear Universal Joint Angle—45, 46, 48000 Series

2. On 46, 48000 remove two differential carrier mounting nuts, one on each side of the lowest nut. Install two special flat washers over studs, then install Rear Bracket J-8973-16 with bent edge toward front and slot to the right, using nuts just removed. On 45000 install bracket as shown in Figure 6-114.

3. Take cable assembly and hook Front Attaching Bracket J-8973-15 over center of front frame cross member. Pull cable tight and position cable all-the-way in slot of rear bracket so one of the stops is to the rear of the bracket.

4. Position Engine Height Plate J-8973-14 vertically with wide end centered against front flange of engine pan. Pull cable down and place in lower notch of plate. See Figure 6-114.

5. Measure perpendicular distance from machined surface immediately in front of slinger on rear pinion flange to top of cable. This distance is given for 45-46-48000 models in Figure 6-114.

b. Adjusting Rear Universal Joint Angle

If the distance measured in Step 5 above was not correct, the pinion nose must be moved up or down as required. This is done by shimming the upper control arms.

Adjust rear universal joint angle using the following procedure:

1. Place a jack under pinion nose. Because of the geometry of the rear suspension, the pinion nose will tend to move downward when released and must be held upward.

2. Loosen nuts and bolts retaining upper control arm brackets to frame. See Figure 6-113.

3. Using jack, raise or lower pinion nose as required to get correct measurement from pinion flange to top of cable.

4. Install shims as required between brackets and frame. See Figure 6-113.

5. Lower jack from under pinion nose and retorque bracket to frame attaching nuts and bolts to 25-35 ft. lbs. Recheck measurement on Kentmore set-up. If dimension is off, loosen bracket to frame nuts and bolts and repeat preceding steps to obtain correct reading.

6. Remove all parts of the alignment set, being careful to avoid kinking cable in handling and storing.

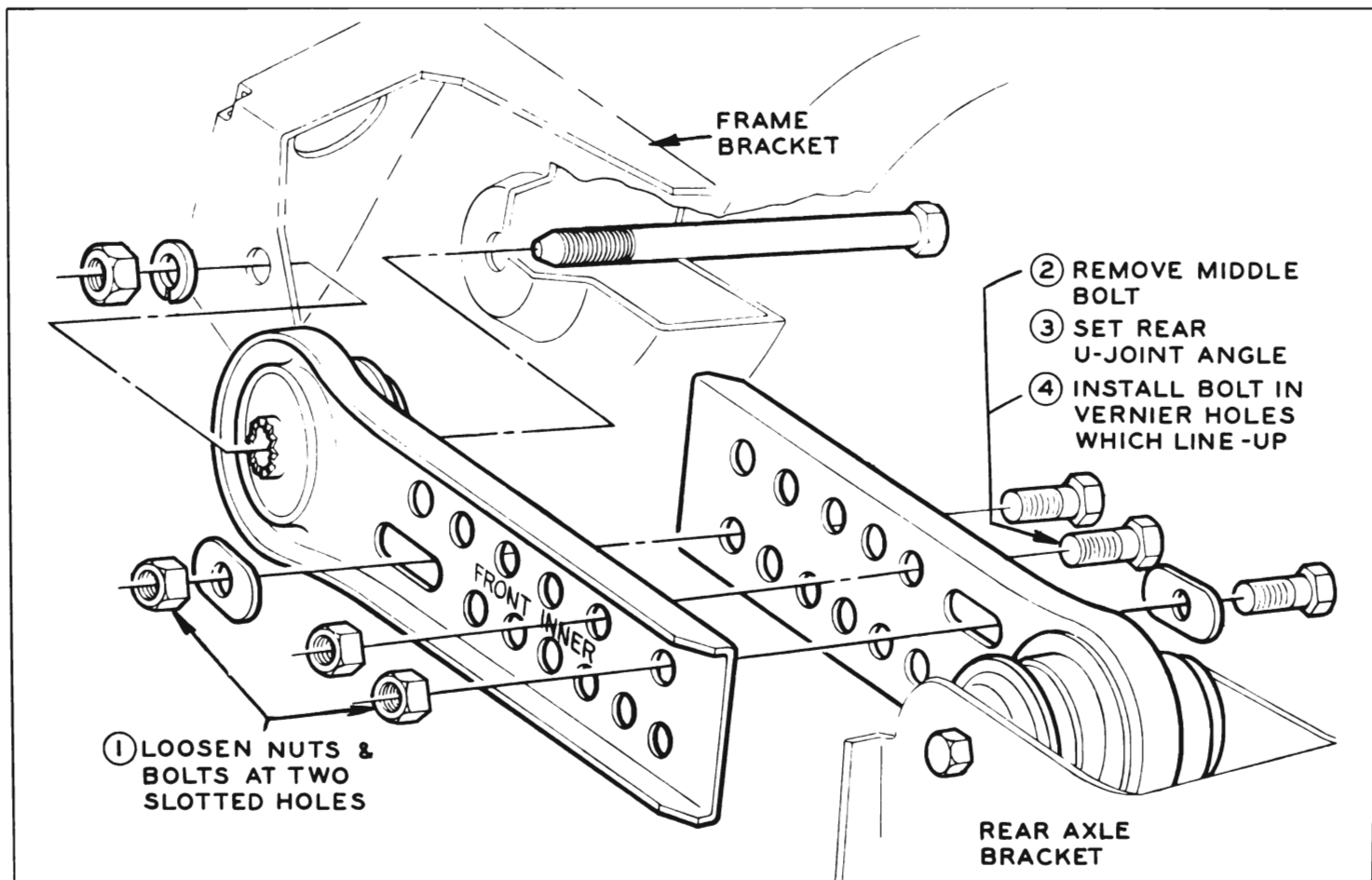

Figure 6-115—Adjusting Rear Universal Joint Angle—49000 Series

7. Reinstall differential carrier nuts and torque to 50 ft. lbs.

6-29 ADJUSTMENT OF UNIVERSAL JOINT ANGLES—49000

Because of the constant velocity joints at the center and rear of the 49000 propeller shaft, the car is not sensitive to pinion angle adjustment. Therefore, no adjustment is necessary. However, if rear CV joint bottoms on underbody, or if propeller shaft is rubbing on the frame tunnel, adjustment must be made to provide sufficient clearance. Adjustment can be made using tools and procedure as described in preceding paragraph differing only in adjustment of vernier upper control arm. Adjust vernier arm as shown in Figure 6-115.

6-30 PROPELLER SHAFT BALANCING PROCEDURE

1. Place the car on a twin post hoist so that the rear of the car is supported on the rear axle housing and the rear wheels are free to rotate.

2. Balancing at the center of the propeller shaft just rearward of the CV Joint is all that is normally required. It is often possible to locate the heavy side of the shaft by holding a crayon or colored pencil close to the shaft while the shaft is rotating (speedometer indicating 40-50 MPH.) and carefully bringing the crayon upwards until it just contacts this rotating shaft. If carefully done, the heavy side (point of maximum runout) only will be marked by the crayon. This normally gives a good indication of which side of the shaft is heavy for unbalance, and serves as a starting point for initial location of the hose clamps.

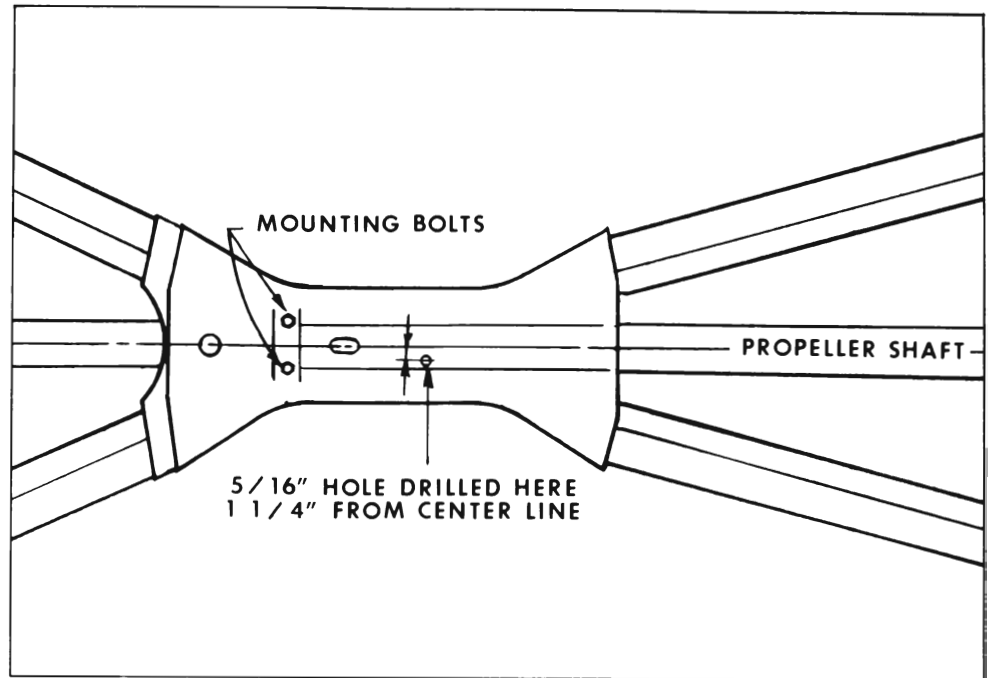

Figure 6-116—Locating Access Hole in Frame—49000 Series

3. Install two (2) Wittek #28 hose clamps (Gr. 1.166, Part #1351813) on the rear propeller shaft and slide them forward until the clamps stop at the nearest balance weight welded to the tube. This involves working the clamps into the frame tunnel with the fingers.

4. On 49000 only, to provide an access hole in the frame tunnel

for inserting a screwdriver to tighten the hose clamps, drill a 5/16" hole located as follows: Measure from the rear of the frame tunnel forward to the first welded-on balance weight. Subtract 1/2" from this measurement; then using this distance, measure from the rear of the frame tunnel forward and mark this distance on the bottom outside frame tunnel. This locates

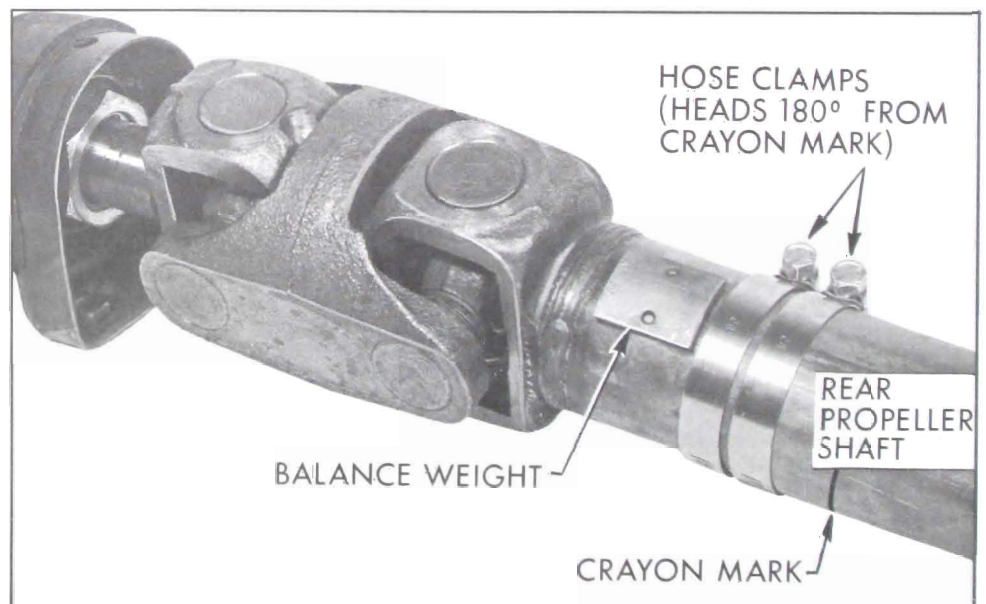

Figure 6-117—Hose Clamps in Place Opposite Crayon Mark

the hole between the clamp screws so both can be reached. Offset the hole approximately 1-1/4" from the car centerline and drill the 5/16" hole. See Figure 6-116.

5. Place the two hose clamps side by side with the heads together and 180° from the crayon marking. See Figure 6-117. Tighten the clamps.

6. Run the car through the speed range to 65 - 70 MPH. If no unbalance is felt, nothing further need be done on the hoist. However, if unbalance still exists, rotate both clamps to the opposite side of the shaft and retighten. Run car again and notice if the unbalance feel is better or worse; if worse, return the clamps to the original position. Apparently the combined weight of the two hose clamp heads was excessive, so to reduce this excess rotate the clamp heads away from each other 45° (one each way from the original position). See Figure

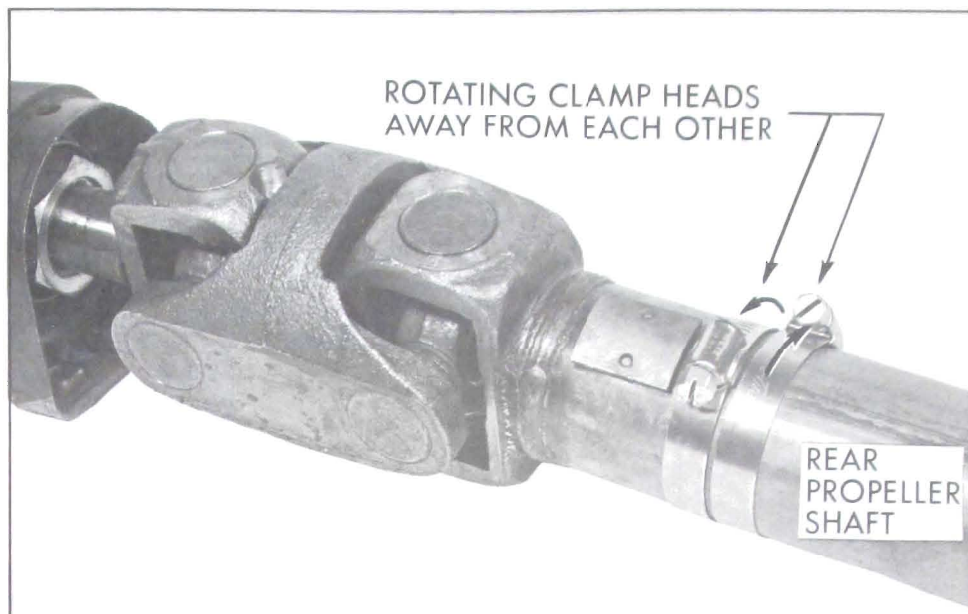

Figure 6-118—Rotating Hose Clamp Heads from Each Other

6-118. Run car and note if unbalance has improved.

7. Continue to rotate the clamps apart in smaller angular increments until the car feel for unbalance is best.

CAUTION: Do not run car on hoist for extended periods due to

danger of overheating the transmission or engine.

8. Roadtest the car again for final check of balance.

NOTE: Vibration felt in the car on the hoist may not show up in a roadtest which is after all the final determining factor.

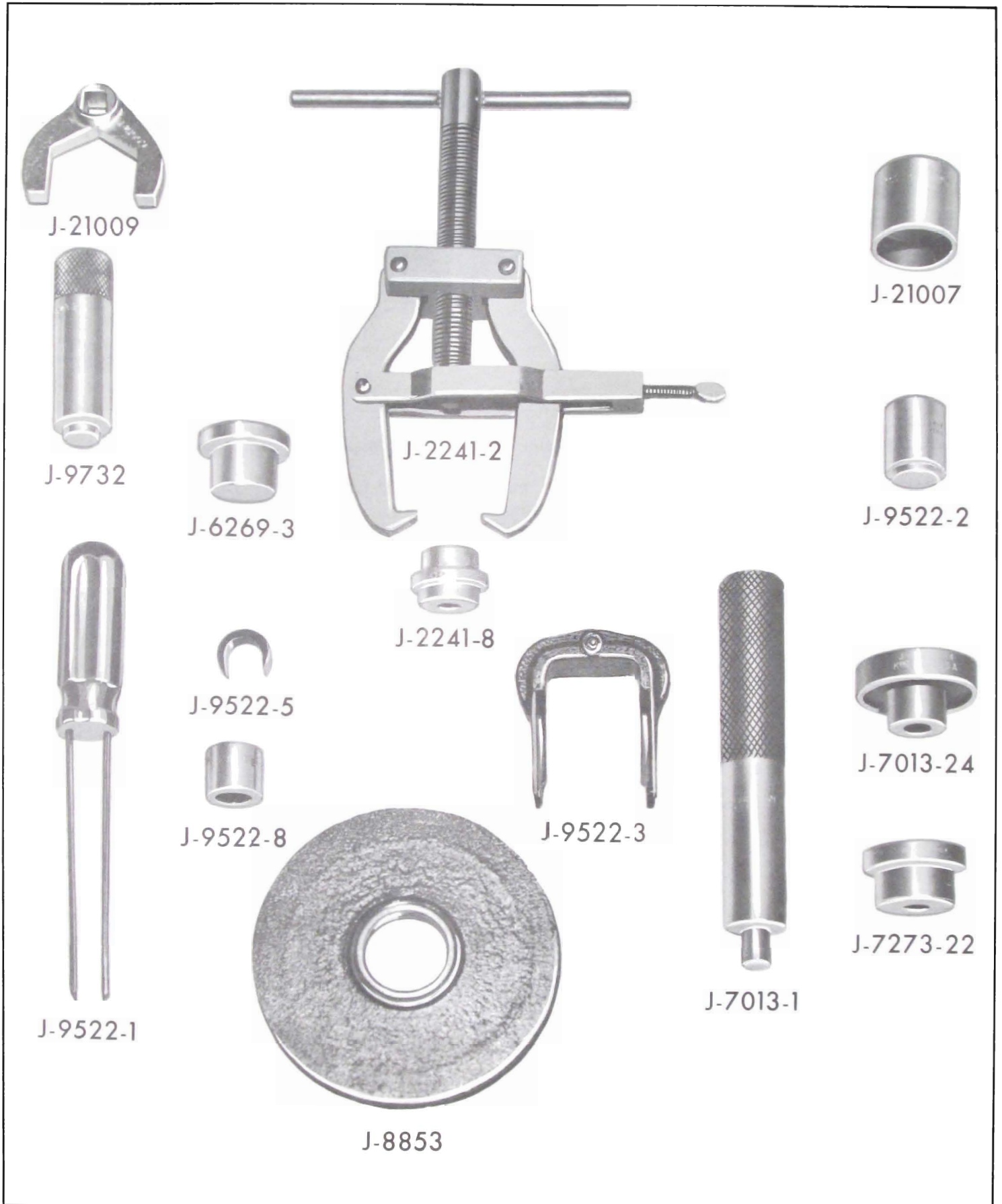

Figure 6-119—Propeller Shaft Tools

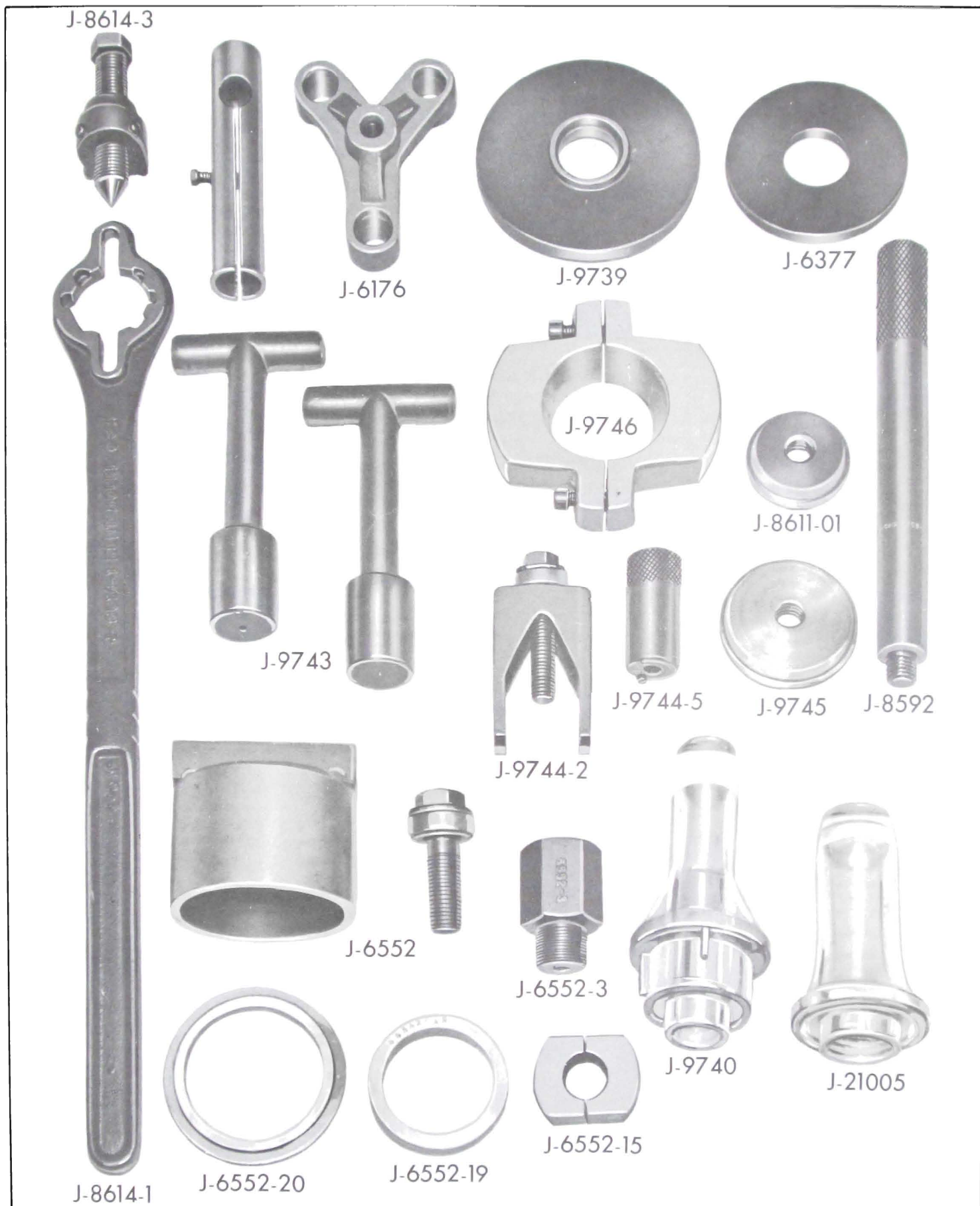

Figure 6-120—Rear Axle Tools