

**SECTION 11-C
OPTIONAL HEATER-AIR CONDITIONER SYSTEM**

CONTENTS OF SECTION 11-C

Paragraph	Subject	Page	Paragraph	Subject	Page
11-10	Specifications	11-36	11-15	Service Procedures	11-77
11-11	Description and Operation of Optional Heater - Air Conditioner System	11-37	11-16	Compressor Clutch, Coil and Shaft Seal, Removal and Installation	11-87
11-12	Description and Operation of Air Conditioner Compressor	11-47	11-17	Disassembly, Inspection and Assembly of Compressor Internal Parts	11-95
11-13	Heater - Air Conditioner Controls and Air Distribution System - 45000, 46000 and 48000 Series	11-57	11-18	Evacuation, Leak Testing and Charging of Air Conditioner	11-103
11-14	Air Distribution System Operation and Trouble Diagnosis - 49000 Series	11-68	11-19	Air Conditioner Functional Test	11-105
			11-20	Air Conditioner Trouble Diagnosis	11-105

11-10 SPECIFICATIONS

a. Tightening Specifications

Part	Location	Ft. Lbs.
Nut	Drive Plate Nut to Compressor Shaft	14-16
Nut	Compressor Rear Head to Shell	19-23
Cap	Schrader Service Valve	4-5

For compressor mounting bracket bolts see Figures 11-92 and 11-93.

Metal Tube Outside Diameter	Thread and Fitting Size	Steel Tubing Torque Lb.-Ft.	Aluminum or Copper Tubing Torque Lb.-Ft.	Nominal Torque Wrench Span
1/4	7/16	10-15	5-7	5/8
3/8	5/8	30-35	11-13	3/4
1/2	3/4	30-35	11-13	7/8
5/8	7/8	30-35	18-21	1 1/16
3/4	1 1/16	30-35	23-28	1 1/4

If a connection is made with steel to aluminum or copper, use torques for aluminum. In other words, use the lower torque specification.

Use steel torques only when both ends of connection are steel.

Figure 11-47—Pipe and Hose Connection Torque Chart

b. Compressor Specifications

Type	Six Cylinder Axial
Make	Frigidaire
Displacement - (cu. in.)	12.6

b. Compressor Specifications (Cont'd.)

Oil	Frigidaire 525 Viscosity
Oil Content (New)	10-1/2 oz. Fluid
Internal Clearances	See Figure 11-102
Air Gap Between Clutch Drive Plate and Pulley022" to .057"
Clutch Type	Magnetic
Belt Tension	See Figures 2-50 and 2-51

c. Miscellaneous Specifications

Refrigerant	Freon 12, Ucon 12, Genetron 12, Isotron 12
System Capacity (Fully Charged)	45000, 46000 and 48000 - 4-1/4 lbs. 49000 - 3-3/4 lbs.
Blower Motor Fuse	30 Amp. Located on Fuse Block
Type of Temperature Control	Suction Throttle Valve

11-11 DESCRIPTION AND OPERATION OF OPTIONAL HEATER-AIR CONDITIONER SYSTEM

a. 45000, 46000 and 48000 Series

The heater-air conditioner system for the 45000, 46000 and 48000 Series cars is a series type, air mix system. The air flows thru the evaporator core, and then may either flow thru, around, or both thru and around the heater core. This arrangement affords the driver with the advantage of being able to cool the air (to dehumidify) and then reheat the air as may be required on cool, damp days. The temperature of the air is controlled by regulation of the mixture between hot and cold air. A vacuum operated water valve is provided to control the flow of coolant to the heater core.

b. 49000 Series

The 49000 Series heater-air conditioner system is an air mix type system; however, the air ducts are situated such that the air flow for air conditioning and the air flow for heating are entirely separate. The temperature of the heated air is controlled by regulation of the mixture of hot

and cold air. The heater portion of the heater-air conditioner system for 49000 Series cars is the same heater used for non-air conditioned cars. For further information pertaining to the heater system refer to Section 11-B.

c. Both Systems, 45000, 46000, 48000, and 49000 Series

Both the 45000, 46000 and 48000 Series system and the 49000 Series system are similar in that the components of the refrigerating circuit are basically identical except for variations in mounting of the components in the engine compartment, adjustment valves and capacities. Both systems use the following components in their refrigeration circuit: (1) compressor, (2) condenser, (3) receiver-dehydrator, (4) evaporator, (5) suction throttle valve, (6) expansion valve, and (7) muffler (see Figures 11-48 and 11-49).

A larger capacity radiator and fan to increase cooling system efficiently are included on all factory equipped cars with air conditioner. Also, a fan clutch is used.

Air conditioner equipped cars have the fuel vapor by-pass sys-

tem. This consists of a special fuel filter and fuel return lines which allow a constant flow of fuel from gas tank to filter and back to tank. This reduces the possibility of vapor lock when operating in extremely hot weather.

Any service work that requires loosening a refrigerant line connection should be performed only by qualified service personnel who have attended either Buick or other automotive air conditioner training schools. Whenever a hose or pipe is disconnected from any unit, refrigerant will escape. Any work involving the handling of refrigerants requires special equipment and a knowledge of its proper use.

The air conditioner uses Schrader valve fittings instead of shut-off service valves; therefore, whenever a part is removed that is in the refrigeration circuit or a line disconnected, the refrigerant must be discharged from system as described in paragraph 11-15, "c".

d. Description of Components

NOTE: See paragraph 11-12 for description of compressor.

1. Hoses. The connecting elements are made from a high temperature, high pressure synthetic

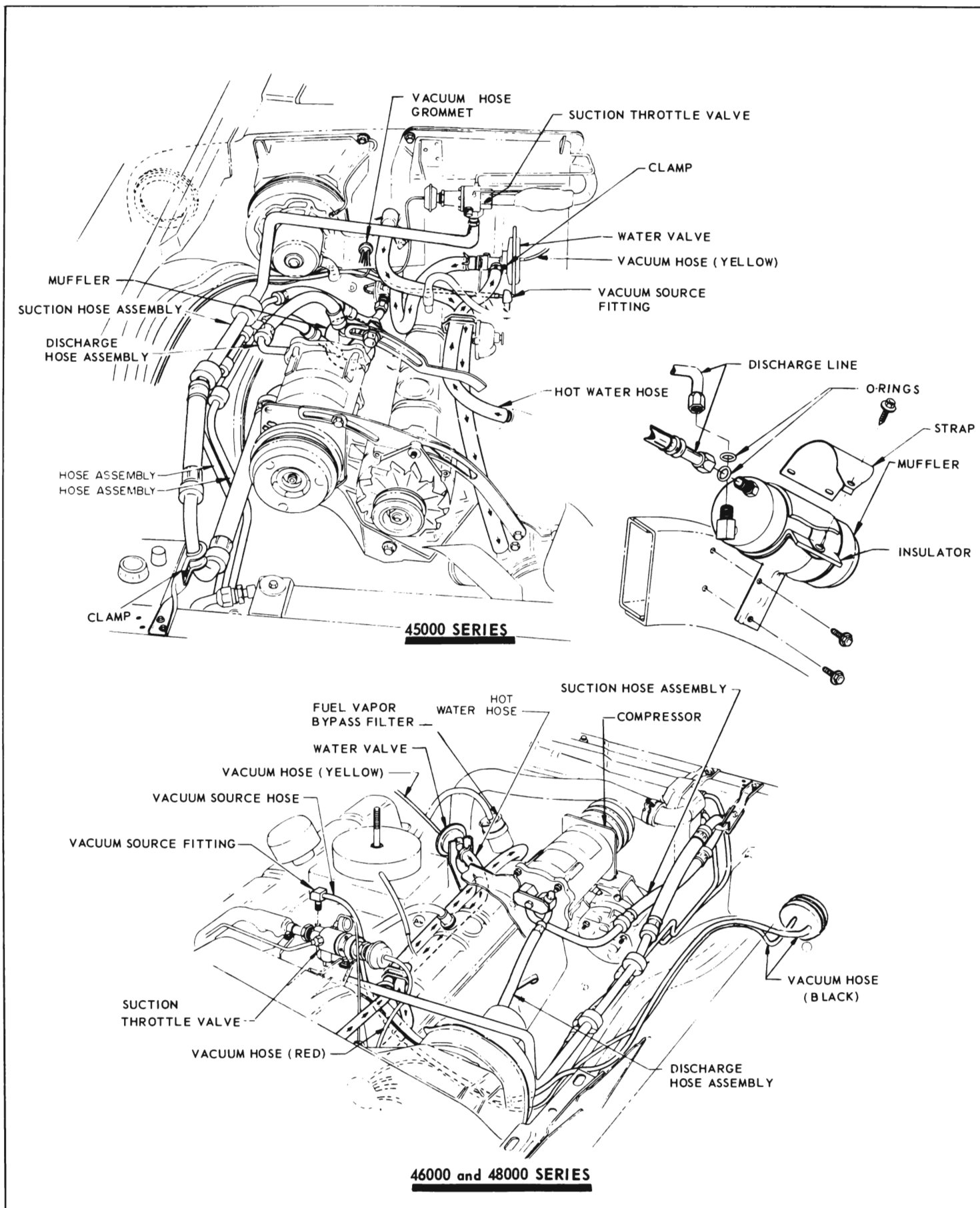
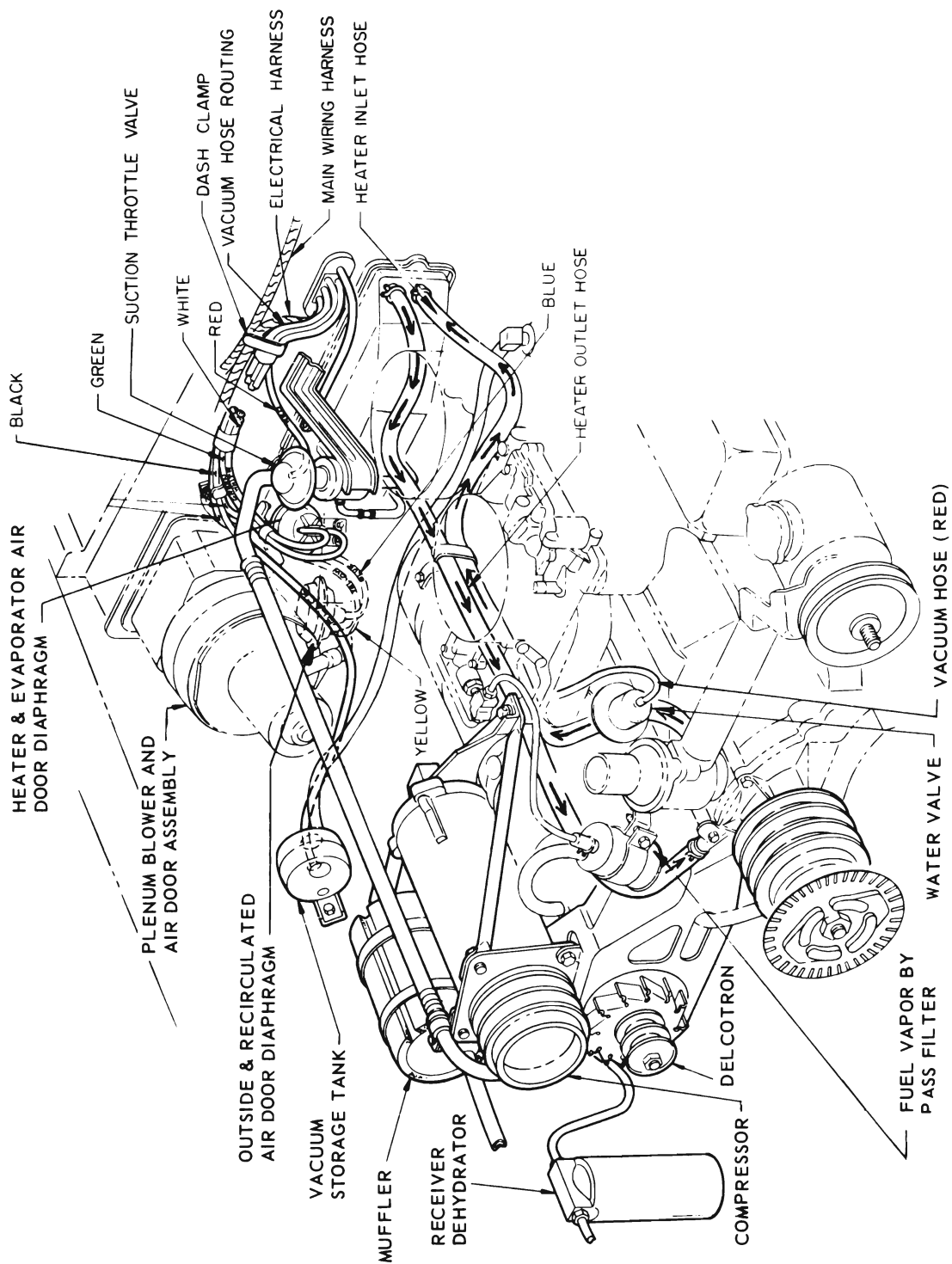

Figure 11-48—Air Conditioner Installation - 45000, 46000 and 48000 Series



49000 SERIES

Figure 11-49—Air Conditioner Installation - 49000 Series

rubber hose with double cord reinforcements. The hose ends are fitted with O-ring fittings.

2. Schrader Service Valves. Two Schrader service valves are used on the air conditioner for evacuating and charging the system. The valve located on the compressor discharge line at rear of compressor, also is used for checking compressor head or discharge pressures. The low pressure valve located on the suction throttle valve is also used for checking evaporator pressure when functional testing system or adjusting suction throttle valve.

3. Condenser. The condenser is similar to the ordinary car radiator but is designed to withstand much higher pressures. The condenser used on all series is of aluminum construction. The condenser is mounted in front of the radiator so that it receives a high volume of air. Air passing over the condenser cools the hot high pressure refrigerant gas, causing it to condense into high pressure liquid refrigerant.

4. Receiver-Dehydrator. The receiver-dehydrator is located at the right front of engine compartment. A liquid indicator or sight glass is an integral part of the outlet pipe of the receiver-dehydrator. The sight glass serves as an aid to diagnosis. The appearance of bubbles or foam beneath the sight glass when ambient temperature is higher than 70°F indicates air or a shortage of refrigerant in the system.

CAUTION: Continuous bubbles may appear in a properly charged system on a cool day. This may be considered normal if temperature of surrounding air is low.

The purpose of the receiver part of assembly is to insure a solid column of liquid refrigerant to the expansion valve at all times, provided the system is properly charged. The dehydrator part of

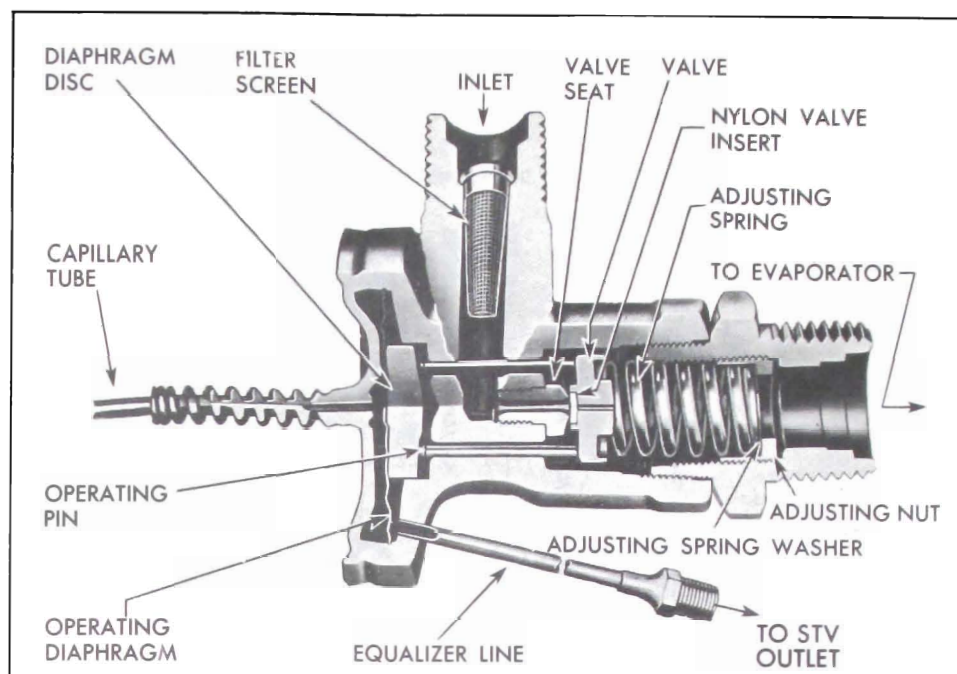

Figure 11-50—Expansion Valve

assembly functions to absorb any moisture that might be present in system after assembly. Also, it traps foreign material which may have entered system during assembly.

NOTE: IN and OUT are stamped on receiver. IN attaches to condenser and OUT to liquid line.

5. Expansion Valve. The expansion valve is located at the inlet to the evaporator core.

The expansion valve consists of a capillary bulb and tube which is connected to an operating diaphragm sealed within the valve itself, and an equalizer line which connects the valve with the suction throttling valve outlet pressure. See Figure 11-50.

The valve contains three operating pins, valve stationary seat, valve, valve carriage, adjusting spring and screw, an inlet which has a fine mesh screen, and an outlet connection (which attaches to the evaporator). The fine mesh screen at the inlet of the valve provides protection to the valve by preventing dirt and other foreign material from entering the valve.

While this valve is located at the inlet of the evaporator, the thermo bulb is attached to the evaporator outlet pipe.

The equalizer line joins the expansion valve to the suction throttle valve outlet so that this pressure will register in the expansion valve.

The purpose of the expansion valve is to regulate the flow of liquid refrigerant into the evaporator automatically in accordance to the requirements of the evaporator.

This valve is the dividing point in the system between high pressure liquid refrigerant supplied from the receiver and relatively low pressure liquid and gaseous refrigerant in the evaporator. It is so designed that the temperature of the refrigerant at the evaporator outlet must have 6°F of superheat before more refrigerant is allowed to enter the evaporator. Superheat is an increase in temperature of the gaseous refrigerant above the temperature at which the refrigerant vaporized.

NOTE: The superheat setting on the 49000 expansion valve is 10°F. For explanation purposes, the 6°F setting of the 45000, 46000 and 48000 will be used.

A capillary tube filled with carbon dioxide and the equalizer line provide the temperature regulation of the expansion valve. This capillary tube is fastened to the low pressure refrigerant pipe coming out of the evaporator so that it communicates the temperature of the refrigerant at this point to the expansion valve. If the temperature differential between the inlet and outlet decreases below 6°F., the expansion valve will automatically reduce the amount of refrigerant entering the evaporator.

If the temperature differential increases, the expansion valve will automatically allow more refrigerant to enter the evaporator.

It is the temperature of the air passing over the evaporator core that determines the amount of refrigerant that will enter and pass through the evaporator. When the air is very warm, the heat transfer from the air to the refrigerant is great and a greater quantity of refrigerant is required to cool the air and to achieve the proper superheat on the refrigerant gas leaving the evaporator. When the air passing over the evaporator is cool, the heat transfer is small and a lesser quantity of refrigerant is required to cool the air and to achieve the proper superheat on the refrigerant gas leaving the evaporator.

A mechanical adjusting nut located within the valve is provided to regulate the amount of refrigerant flow through the valve; when turned, move the spring seat to increase or decrease the tension on the needle valve carriage spring. By varying the tension on this spring, it is possible to regulate the point at which the needle valve begins to open or

close, thereby regulating refrigerant flow into the evaporator. As this adjustment feature is inside the valve, no external adjustment is possible. All expansion valves are preset at the time of manufacture.

When the air conditioning system has not been operating, all pressure within the expansion valve assembly will have equalized at the ambient (surrounding air) temperature, thus the pressure above and below the operating diaphragm and at the inlet and outlet side of the valve will be equal. (Pressure under the diaphragm is evaporator pressure. It reaches this area by means of clearance around the operating pins which connects the area under the diaphragm with the evaporator pressure area.) While pressures in the expansion valve are almost equal, the addition of the valve adjusting spring pressure behind the needle will hold the needle valve over to close the needle valve orifice.

When the air conditioning system first begins to operate, the compressor will immediately begin to draw refrigerant from the evaporator and in the area under the operating diaphragm. As the pressure in this area decreases, the pressure above the diaphragm exerted by the carbon dioxide in the capillary tube will overcome spring pressure and push the diaphragm against the operating pins, which in turn will force the needle off its seat.

Refrigerant will then pass through the expansion valve into the evaporator where it will boil at a temperature corresponding to the pressure in the evaporator. This will begin cooling the air passing over the evaporator, and, also it will begin to cool the evaporator outlet pipe.

The valve adjusting spring is calibrated so that the pressure of the refrigerant in the evaporator

outlet pipe and equalizer line to the valve, plus the spring force, will equal the force above the operating diaphragm when the temperature of the refrigerant in the evaporator outlet is 6°F. above the temperature of the refrigerant entering the evaporator. In other words, the refrigerant should remain in the evaporator long enough to completely vaporize and then warm (superheat) 6°F.

If the temperature differential begins to go below 6°F. (outlet pipe becoming too cold) carbon dioxide pressure in the capillary tube and area above the diaphragm decreases, allowing the valve adjusting spring to move the needle valve towards its seat closing off the flow of refrigerant past the needle valve.

If the temperature differential begins to go above 6°F. (outlet pipe too warm), the pressure in the capillary tube and area above the operation diaphragm will increase, pushing this diaphragm against the operating pins to open the needle valve further, admitting the needle valve further, admitting more refrigerant to the evaporator.

The equalizer line permits the STV outlet pressure to be imposed on the expansion valve diaphragm, thus, over-riding its normal control of liquid refrigerant. As the compressor capacity becomes greater than the evaporator load, the drop in compressor suction line pressure forces the expansion valve to flood liquid through the evaporator and STV, thus preventing the suction pressure from dropping below a predetermined pressure.

The equalizer line is used primarily to prevent prolonged and constant operation of the compressor in vacuum conditions. This operation is considered undesirable both from a noise angle and from possibility of subjecting

the compressor to reduced oil return. Additional considerations for having the external equalized expansion valve are to maintain a full evaporator during throttling, and also guard against non-condensibles entering the system, especially through loosened fittings.

6. Evaporator. The evaporator core on the 45000, 46000 and 48000 Series is of plate type design and is located near the center of the cowl in the engine compartment. The 49000 Series evaporator is of the tube and fin (Series) design and is located under the right side of the instrument panel.

The purpose of the evaporator core is to cool and dehumidify the air that is flowing through it when the system air conditioner is in operation. High pressure liquid refrigerant flows through the orifice in the expansion valve into the low pressure area of the evaporator. This regulated flow of refrigerant boils immediately.

Heat from the core surface is lost thru boiling and vaporizing of the refrigerant which is cooler than the core, thereby cooling the core. The air passing over the evaporator loses its heat to the cooler surface of the core. As the process of heat loss from the air to the evaporator core surface is taking place, moisture in the air condenses on the outside surface of the evaporator core and is drained off.

Since Refrigerant-12 will boil at 21.7° F. below zero at atmospheric pressure (see Figure 11-51) while water freezes at 32° F., it becomes obvious that the temperature in the evaporator must be controlled so that the water collecting on the core surface will not freeze in the fins of the core and block off the air passages. In order to control the temperature, it is necessary to control the amount of refrigerant entering the core and the pressure inside the evaporator.

To obtain maximum cooling, the refrigerant must remain in the core long enough to completely vaporize and then superheat a minimum of 6° F. If too much or too little refrigerant is present in the core, then maximum cooling efficiency is lost. The expansion valve in conjunction with the suction throttling valve is used to provide this necessary refrigerant volume control.

An oil bleed line is connected from the bottom of the evaporator to the outlet side (compressor suction) of the suction throttle valve. This bleed line is connected to a check valve on the suction throttle valve. The check valve is a special low force spring valve core.

The bleed line is in the system as an insurance measure to provide increased compressor life during times of low refrigerant charge. During normal-charge conditions this line is of no particular benefit as the compressor runs on an adequate oil supply. With partially depleted refrigerant charge, oil and refrigerant mixture will flow from the bottom tank of the evaporator through the oil bleed line to the compressor. This oil flow helps to prevent oil deficiencies in the compressor that could arise under these conditions. During times of zero-charge no refrigerant will be available to carry oil back to the compressor. It is therefore important that completely discharged systems be kept to a minimum of operation, thus preventing seizure.

The bleed line's check valve in the STV opens at 5 psi differential pressure between the evaporator inlet pressure and the STV outlet pressure. This check valve is fully open when these two pressures exceed 12 psi differential. Below the 5 psi differential, the check valve will be closed to prevent refrigerant and oil from flowing out the bottom of the evaporator. This feature prevents

REFRIGERANT-12 PRESSURE-TEMPERATURE RELATIONSHIP			
The table below indicates the pressure of Refrigerant-12 at various temperatures. For instance, a drum of Refrigerant at a temperature of 80° F. will have a pressure of 84.1 psi. If it is heated to 125° F. the pressure will increase to 167.5 psi. It also can be used conversely to determine the temperature at which Refrigerant-12 boils under various pressures. For example, at a pressure of 30.1 psi, Refrigerant boils at 32° F.			
TEMP. (°F.)	PRESSURE (PSIG)	TEMP. (°F.)	PRESSURE (PSIG)
-21.7	0 (atmospheric pressure)	55	52.0
-20	2.4	60	57.7
-10	4.5	70	70.1
-5	6.8	75	76.9
0	9.2	80	84.1
5	11.8	85	91.7
10	14.7	90	99.6
15	17.7	95	108.1
20	21.1	100	116.9
25	24.6	105	126.2
30	28.5	110	136.0
32	30.1	115	146.5
35	32.6	120	157.1
40	37.0	125	167.5
45	41.7	130	179.0
50	46.7	140	204.5

Figure 11-51—Pressure and Temperature Relationship of Refrigerant-12

refrigerant cooling capacity losses within the evaporator as may occur when driving thru heavy traffic when cooling demands are greatest on the system due to low rpm of the engine.

At all times when the compressor capacity (evaporator inlet pressure) exceeds the evaporator load demands by 5 psi or greater, this valve starts to open. It then permits refrigerant and oil to flow from the evaporator bottom tank to the inlet of the compressor.

7. Suction Throttle Valve. Two different suction throttle valves are used. One for the 45000, 46000 and 48000 air conditioner and one for the 49000 air conditioner. The difference between these two valves is the method of controlling the setting of the valve for less cooling.

The 45000, 46000 and 48000 has a two position suction throttle valve which obtains the maximum cooling setting by applying vacuum to its vacuum diaphragm. For setting this valve for less cooling, the vacuum is exhausted from the diaphragm.

The 49000 suction throttle valve has a vacuum diaphragm of different construction. Maximum

cooling is obtained when vacuum is not applied to the diaphragm. A vacuum modulator is used with the 49000 suction throttle valve to vary the vacuum to the diaphragm from 0 to 6-1/2 inches and set it at a higher setting (less cooling). The greater the vacuum present in the diaphragm (up to 6-1/2 inches) the higher the air conditioner outlet temperature.

The suction throttle valve (STV) controls the evaporator pressure and in turn the evaporator air outlet temperature. Also the STV prevents freezing of the condensation on the evaporator core surface. The STV consists of a valve body, piston, piston diaphragm, control spring, diaphragm cover, diaphragm cap and vacuum diaphragm. See Figures 11-52 and 11-53.

The inside of the piston is hollow and is open to the piston diaphragm by small holes in the end of the piston. Located in the lower extremity of the piston is a fine mesh screen, held in place by a retainer. The purpose of this screen is to prevent any foreign particle of any substance entering the piston and lodging in the holes drilled in the piston wall and possibly scoring the surface of the body, thus interfering with its proper operation.

The piston diaphragm retains the piston to it by a tab on the front side and has the cup held against it by the spring on the rear side. The vacuum diaphragm actuating pin fits in the end of the cup. The body of the vacuum diaphragm threads into the valve cover and determines the amount of spring tension on the cup. The vacuum diaphragm is locked in position by a locknut.

On the 49000 Series, the suction throttling valve vacuum diaphragm is connected to the vacuum modulator on the instrument panel by a small hose. When vacuum is present on the diaphragm, it is pulled toward the

piston and its pin adds to the spring pressure on the piston diaphragm.

The vacuum diaphragm on the 45000, 46000 and 48000 suction throttle valve is connected to a vacuum disc switch which is operated by the WARMER lever. The vacuum diaphragm has a spring inside of it. See Figure 11-52. This spring adds to the pressure of the large spring located in the cover when vacuum is not present in diaphragm. When vacuum is applied, the vacuum diaphragm compresses the spring inside it and the spring tension is reduced on the piston diaphragm.

The STV inlet is connected to the evaporator outlet and its outlet is connected to the compressor suction port. See Figure 11-52.

The flow of the low pressure vapor from the evaporator to the compressor is determined and controlled by the position of the piston in the valve body of the STV. The position of the piston in the body is determined by the balance of the forces that are applied to the piston diaphragm. These forces consist of the refrigerant vapor pressure returning from the evaporator on one side and the spring tension, plus the force of the actuating pin on the other side. (The actuating pin adds or subtracts to the spring pressure.) Movement of the piston permits vapor to pass around piston and then on to the compressor inlet.

During the time that maximum cooling is being produced, the STV vacuum diaphragm on the 49000 does not have vacuum applied to it, while the 45000, 46000 and 48000 vacuum diaphragm has at least 4-1/2 inches of vacuum applied to it. The full flow of low pressure refrigerant vapor is being returned to the compressor to permit it to exert its full capacity on the evaporator and produce

maximum cooling. Under most operating conditions, STV inlet and outlet pressures will not be the same as there will be some throttling to prevent evaporator icing.

When the operator desires to raise the temperature within the car, the controls are changed to apply engine vacuum to the 49000 Series STV vacuum diaphragm. On the 45000, 46000 and 48000 the vacuum is exhausted from the vacuum diaphragm. This checks or throttles the flow of the low pressure vapor returning to the compressor. This results in a higher pressure to be maintained in the evaporator assembly. The STV outlet pressure will also increase, but the differential between STV inlet and outlet will be greater than when STV is at maximum cooling.

(a) Maximum cooling setting of 49000 STV -- The maximum cooling setting of the 49000 STV is obtained when there is no vacuum present at its vacuum diaphragm and the spring tension is the only controlling factor. When at the maximum cool position, evaporating pressure is allowed to go to a minimum of 20 to 22 psi. If pressure is allowed to go any lower, icing of the evaporator core will occur.

(b) Minimum cooling setting of 49000 STV -- The minimum cooling setting of the 49000 STV is obtained when 6-1/2" ($\pm 1/2$ ") of vacuum is applied to STV vacuum diaphragm. To move the piston in the STV, the evaporator pressure must overcome spring tension plus the force applied by the actuating pin to the piston diaphragm. This force on the piston's diaphragm maintains an evaporator pressure of approximately 50 psi minimum.

(c) Maximum cooling setting of the 45000, 46000 and 48000 STV. The maximum cooling setting of the 45000, 46000 and 48000 STV

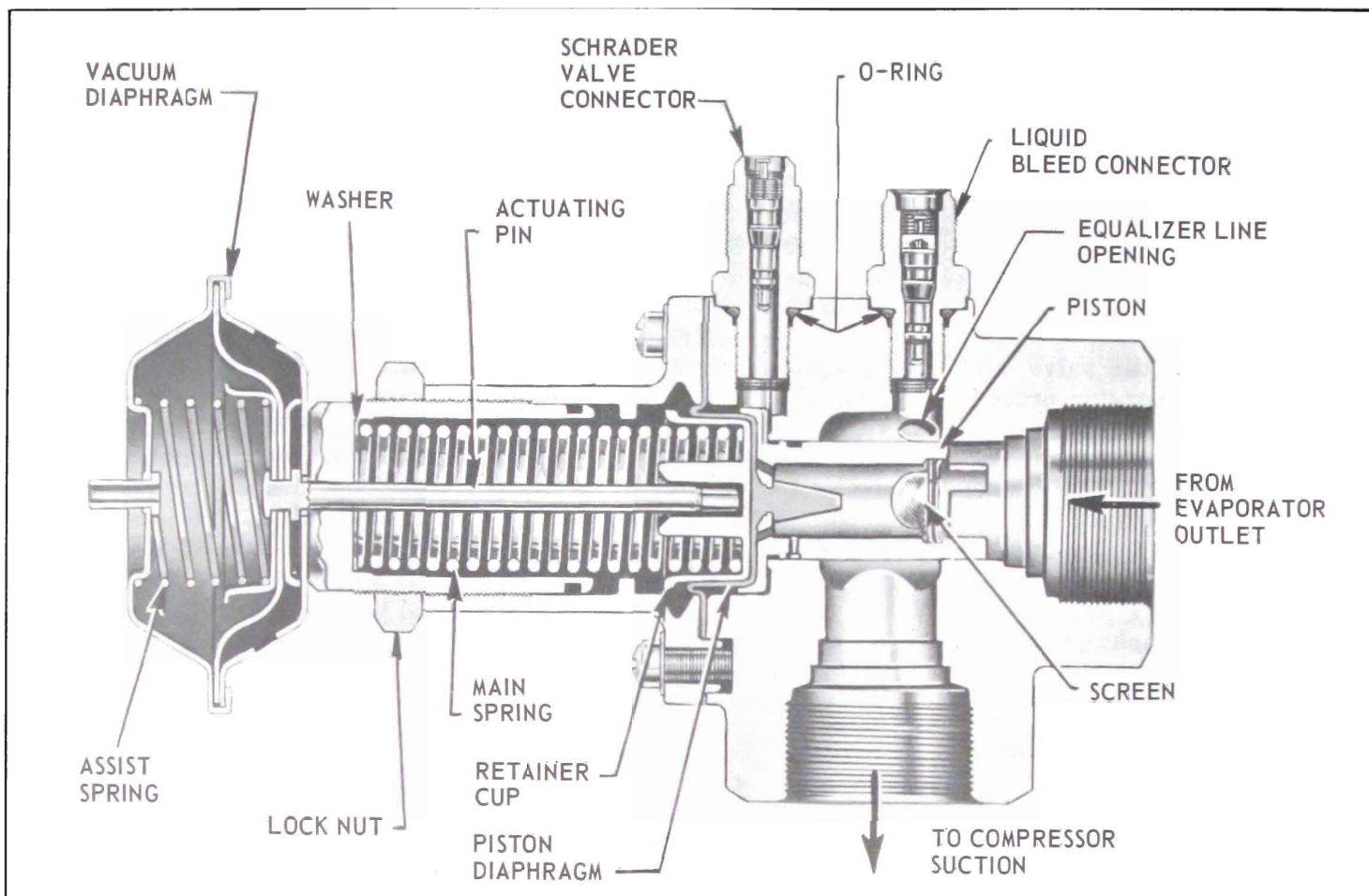

Figure 11-52—Suction Throttling Valve - 45000, 46000 and 48000 Series

is obtained when 4-1/2 inches of vacuum is applied to the STV vacuum diaphragm. The internal spring in the diaphragm is compressed, thus the spring in the cover is the only controlling factor. When at the maximum cooling position, evaporator pressure is allowed to go to a minimum of 29-31 psi. If pressure is allowed to go lower, icing of the evaporator will occur.

(d) Minimum cooling setting of the 45000, 46000 and 48000 STV. The minimum cooling setting is obtained when vacuum is not applied to the vacuum diaphragm. The diaphragm spring tension is added to the tension of the spring in the cover. The evaporator pressure then must overcome both springs to move the piston.

The evaporator pressure will be maintained at approximately 32 to 34 psi.

NOTE: At 60 mph it will not be unusual for the compressor inlet pressure to be from 10 to 15 psi, while the evaporator is controlled at 30 psi. Frost accumulates on the compressor inlet line after prolonged operation at these conditions. At minimum, or further reduced-load conditions, when the throttling demands on the STV are again increased, the compressor inlet pressure may drop to zero psi, or even 6" — 8" of vacuum. Compressor inlet temperatures at these reduced load conditions may approach minus 30° F. so that even frosting of the compressor rear head is possible.

8. Vacuum Modulator - 49000.

The vacuum modulator which controls the amount of vacuum to the 49000 suction throttle valve vacuum diaphragm, is mounted on the air conditioner control assembly on the center console. It is activated by the air conditioner temperature control lever and the FAN switch control lever.

Engine intake manifold vacuum is present at the vacuum modulator when the air conditioner control system is energized. The vacuum modulator controls the output vacuum to the suction throttling valve from 6-7 inches vacuum at minimum cooling, to 0 inches vacuum at maximum cooling. When air conditioner temperature control lever is moved from left to right, the vacuum is gradually decreased from 6-7 inches to a minimum of 2 1/2 inches when the

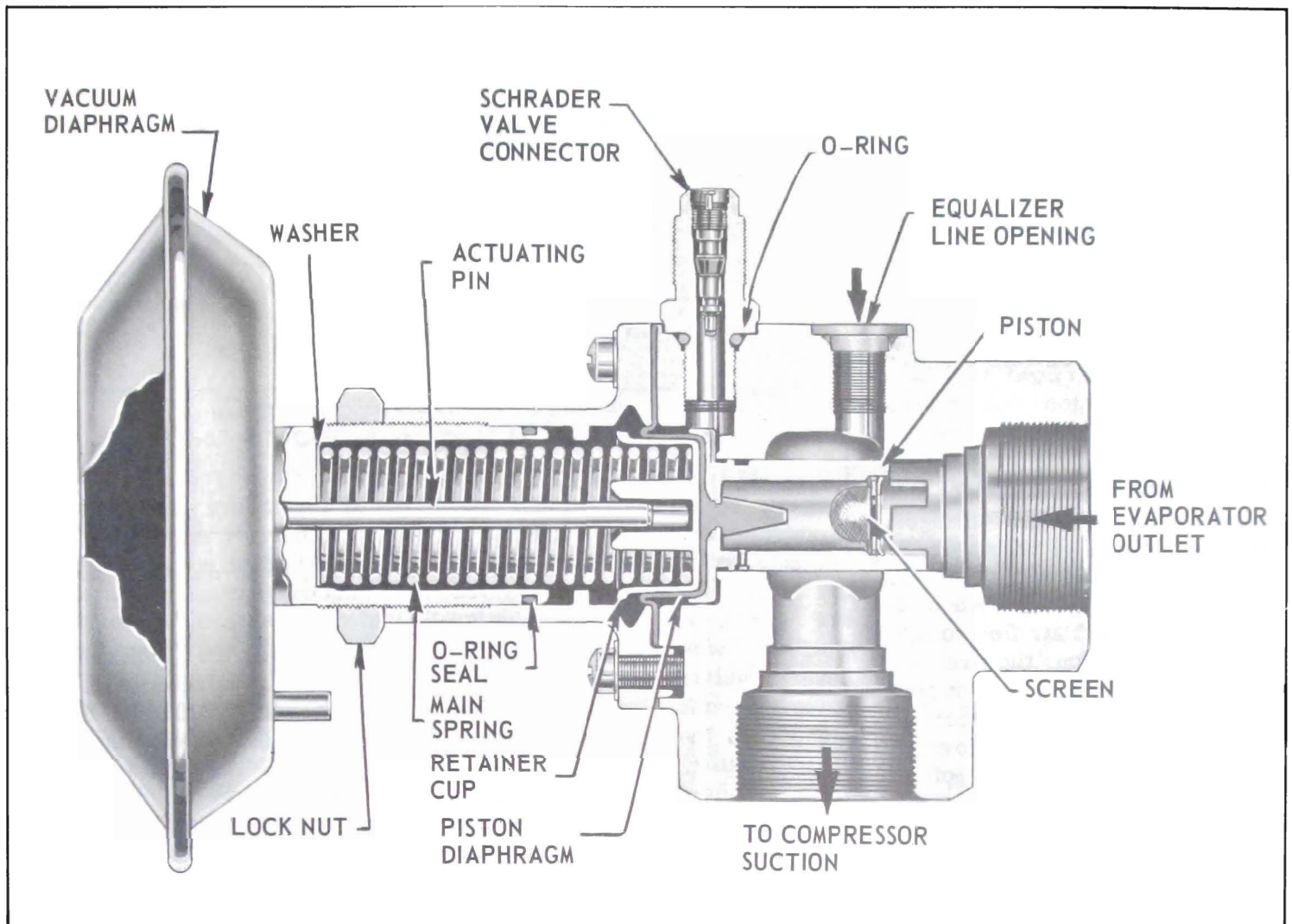

Figure 11-53—Suction Throttling Valve - 49000 Series

lever is full on. When the air conditioning temperature lever is full on and the FAN switch control is on HIGH position, the modulator shuts off the vacuum supply to the suction throttle valve vacuum diaphragm.

9. Air Outlets. The air conditioner air outlets are entirely separate from the heater outlets and are located as shown in Figures 11-54 and 11-55.

Air is introduced into the car through three outlets, two at each end of the instrument panel and one at the upper center of the instrument panel.

The outer outlets have a rotating ball to control air flow direction. See Figure 11-56.

e. Air Conditioner Controls— 49000 Series

NOTE: See paragraph 11-13 for 45000, 46000 and 48000 controls.

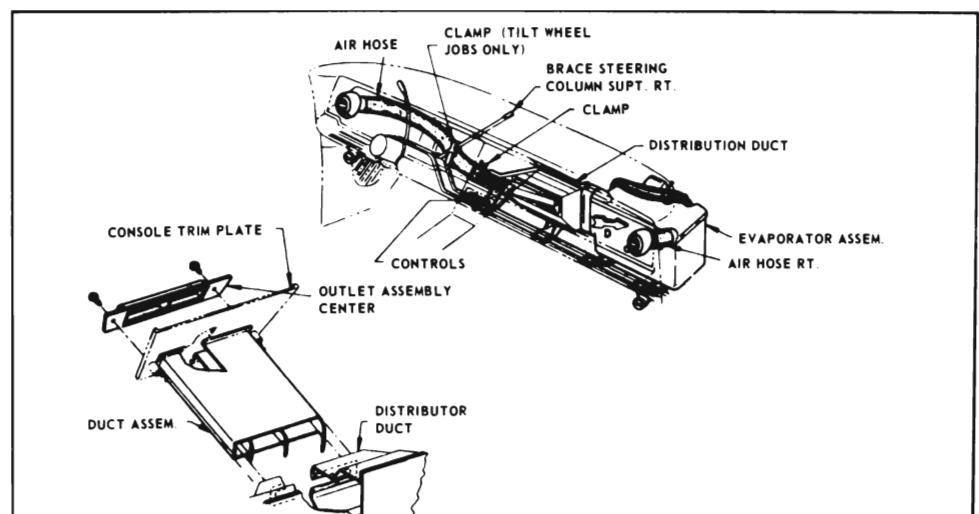

Figure 11-54—Air Conditioner Outlets - 49000 Series

The air conditioner control levers for the 49000 are located directly under the heater control levers. See Figure 11-57. The vent control knobs are attached to the bottom of the instrument panel.

Control of the air conditioner is accomplished by use of three control levers; the air conditioner temperature control lever, the air control lever, and the FAN switch control. These controls function as follows:

1. Air Control Lever - Movement of the lever to VENT position performs three system changes. The outside and recirculated air door is fully opened, and the heater and evaporator air door is positioned to duct air flow to A/C outlets. In addition, the first half of the double contact circuit control switch closes and operates the blower motor at low-low speed. Further movement of the control lever to NORMAL position closes the second half of the circuit switch, thereby causing the compressor magnetic clutch to engage. At this point the air conditioner system begins to operate and the air flow is cooled. RECIRC position of the lever partially closes the outside and recirculated air door so that a portion of the air from inside the car recirculates thru the system.

2. Air Conditioner Temperature Control Lever - Movement of the lever from LOW to COOLER positions progressively decreases vacuum to the suction throttling valve by closing of the vacuum modulator situated on the control assembly.

Positioning of the control lever from LOW to COOLER positions progressively reduces the vacuum to the vacuum diaphragm of the STV. As vacuum is reduced, the temperature of the air flow is proportionately reduced.

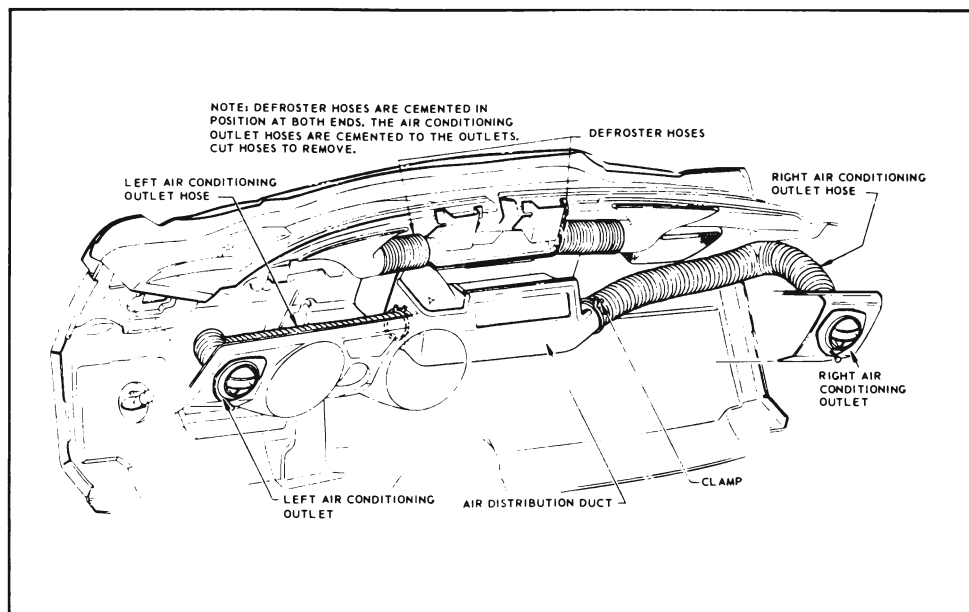

Figure 11-55—Air Conditioner Outlets - 45000, 46000 and 48000 Series

3. FAN Switch Control - This lever regulates the blower speeds to low, medium, or high. In addition, when the lever is moved to HIGH position, the vacuum modulator is permitted to be completely shut off and all vacuum is removed from the vacuum diaphragm of the suction throttling valve, provided the air conditioner temperature lever is in COOLER position. When the FAN lever is in HIGH position, the air lever in RECIRC, and the air conditioner temperature lever in COOLER position — maximum cooling will result.

outside air as the air passes over the cooling surfaces of the condenser. The cooling of the gas causes it to condense into liquid refrigerant. The liquid refrigerant, still under high pressure, passes from the bottom of the condenser into the receiver-dehydrator. The receiver acts as a reservoir for the liquid.

The liquid refrigerant flows from receiver-dehydrator to the expansion valve. The valve meters the high pressure refrigerant flow into the evaporator. Since the

f. Operation of Air Conditioner Refrigeration Circuit

Cool refrigerant gas is drawn into the compressor from the evaporator and pumped from the compressor to the condenser under high pressure. See Figures 11-58 and 11-59. This high pressure gas will also have a high temperature as a result of being subjected to compression. As this gas passes through the condenser, the high pressure, high temperature gas rejects its heat to the

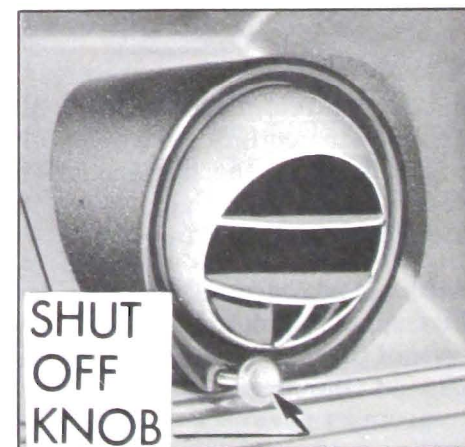

Figure 11-56—Air Conditioner Outer Outlet - 49000 Series

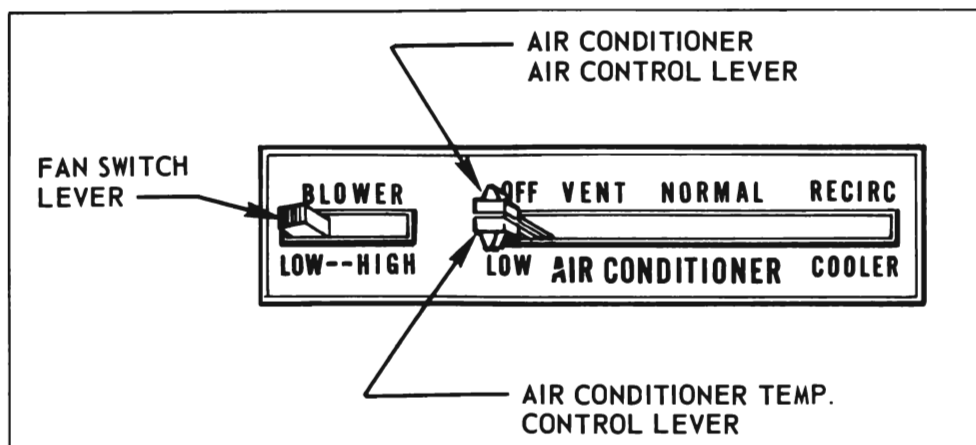

Figure 11-57—Air Conditioner Control Assembly - 49000 Series

pressure in the evaporator is relatively low, the refrigerant immediately begins to boil. As the refrigerant passes through the evaporator, it continues to boil, drawing heat from the surface of the evaporator core. The warm air passing over the evaporator rejects its heat to the cooler surfaces of the evaporator core. Any moisture in the air condenses on the cool surface of the core, resulting in cool dehumidified air entering inside the car. By the time the gas leaves the evaporator it has completely vaporized and is slightly super-heated. Super-heat is an increase in temperature of the gaseous refrigerant above the temperature at which the refrigerant vaporized.

The pressure in the evaporator is controlled by the suction throttle valve as described in subparagraph "d", item 7.

Refrigerant vapor passing through the evaporator, flows through the suction throttle valve and is returned to the compressor where the refrigeration cycle is repeated.

11-12 DESCRIPTION AND OPERATION OF AIR CONDITIONER COMPRESSOR

The compressor is mounted on the right front of the engine over

the generator. The compressor is of basic double action piston design. Three horizontal double acting pistons make up a six cylinder compressor, and are mounted axially around the compressor shaft to operate in a front and rear cylinder assembly.

These pistons operate in a 1-1/2 inch bore, have a 1-1/8 inch stroke and are actuated by a swash plate pressed on the compressor shaft. See Figures 11-60 and 11-61.

Reed type suction and discharge valves are mounted in a valve plate between the cylinder assembly and the head at each end of the compressor. The heads are connected with each other by gas-tight passage ways which direct refrigerant gas to a common output.

a. Suction Reed Valves and Discharge Valve Plates

A three-reed suction valve disc is assembled to both the front and rear cylinder heads. See Figure 11-62. These reeds open when the pistons are on the intake portion of their stroke to allow the low pressure vapor to flow into the cylinders.

When the pistons reverse and are on the compression portion of

their stroke, the reed valves close against their seats to prevent the high pressure vapor being forced back into the low side of the system.

There are two discharge valve plate assemblies, each having three reeds and retainers positioned to direct the high pressure vapor from the cylinders into the outer annular cavities of the front and rear head castings. When the piston has completed its compression stroke and reverses to the suction stroke, the high pressure vapor in the discharge cavity causes the reeds to close, thus maintaining the differential of pressure between the high and low pressure areas.

b. Cylinder Heads

Each cylinder head contains suction and discharge cavities. In addition, the rear head contains an oil pump cavity in the center of the suction cavity to house the oil pump gears (which are driven by the compressor mainshaft). The suction cavity is in the center and indexes with the suction reeds. The discharge cavity is around the outside and indexes with the discharge reeds.

These cavities are sealed from each other with a teflon seal molded into the cylinder heads. The discharge cavity is sealed from the outside of the compressor by an "O" ring seal which rests in a chamfered relief in the cylinder head and compresses against the compressor body.

Both cylinder heads are connected with each other; the suction cavities by a flat suction pass cover, the discharge cavity by a discharge tube pressed into each head. (Service discharge tube assemblies are sealed with "O" rings and bushings.)

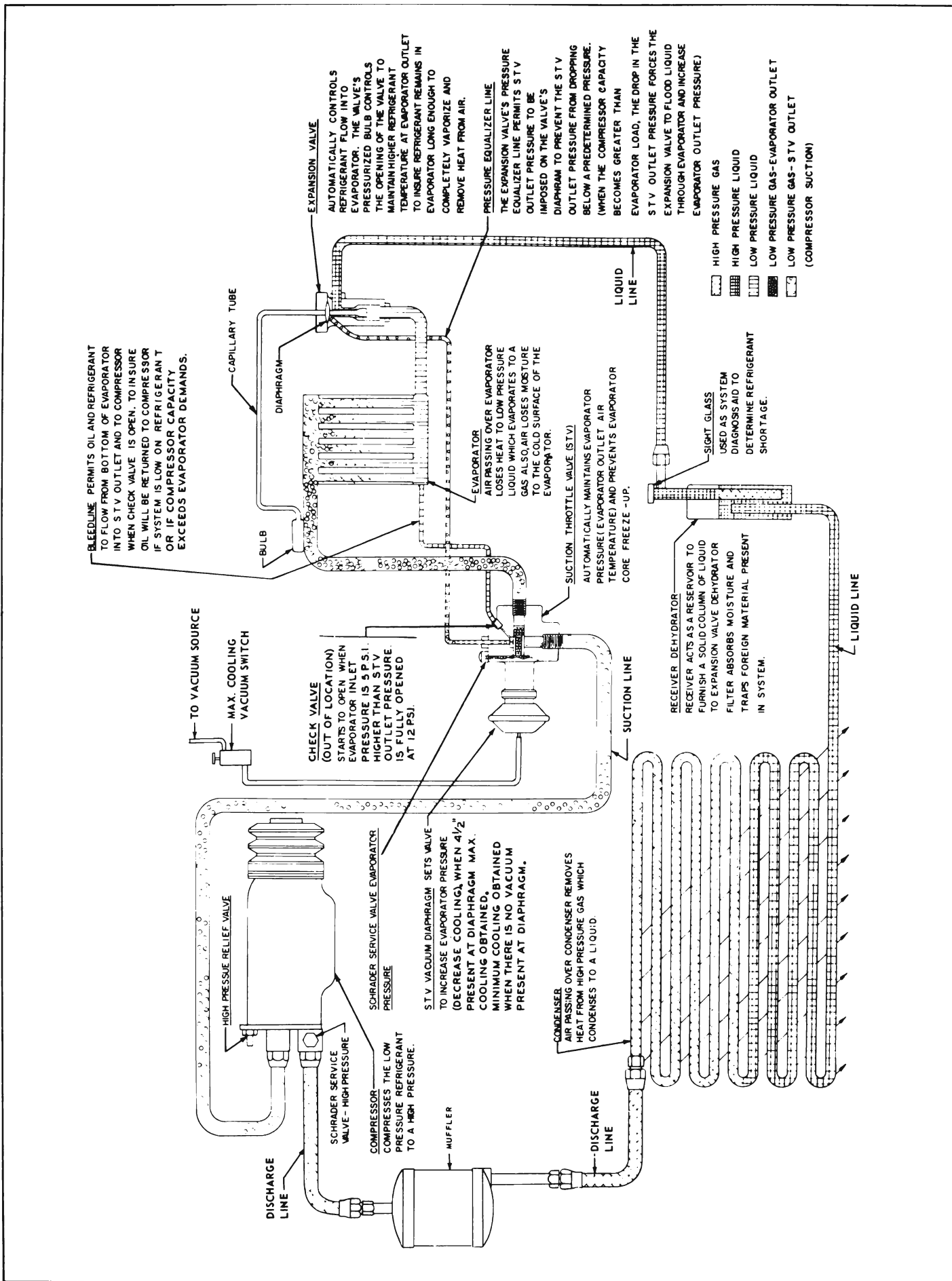

Figure 11-58—Air Conditioner Refrigerant Circuit - 45000, 46000 and 48000 Series

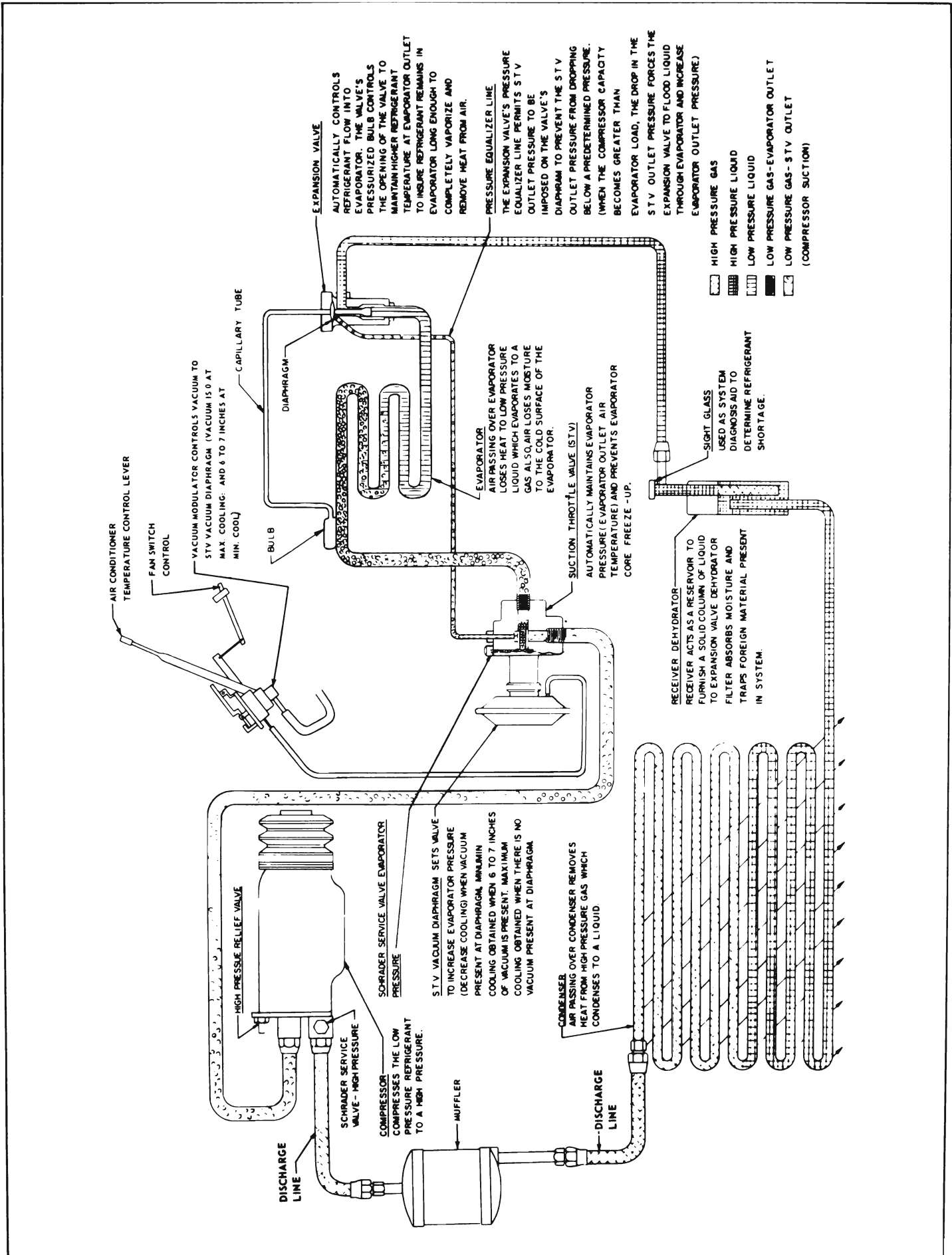

Figure 11-59—Air Conditioner Refrigerant Circuit - 49000 Series

c. Oil Pump

An oil pump mounted at the rear of the compressor picks up oil from the bottom of the compressor and pumps it to the internal parts. The inner gear has a "D" shaped hole in the center which fits over a matching "D" flat on the rear of the main shaft. The outer driven gear has internal gear teeth which mesh with the external teeth on the inner (drive) gear.

d. Main Shaft

The compressor main shaft is driven by the pulley when the magnetic clutch is energized. The shaft extends through the compressor front head, to the compressor rear head and drives the oil pump in the rear head. The shaft is supported by a needle roller bearing located in the front half of the cylinder and a similar needle roller bearing in the rear half of the cylinder.

A 3/16 inch diameter oil passage extends from the rear oil pump cavity to the shaft seal cavity. Four 5/64 inch diameter holes are drilled at 90 degrees to the main oil passage. These drilled passages direct oil, under pump pressure, to the shaft seal surfaces, thrust bearings, and shaft

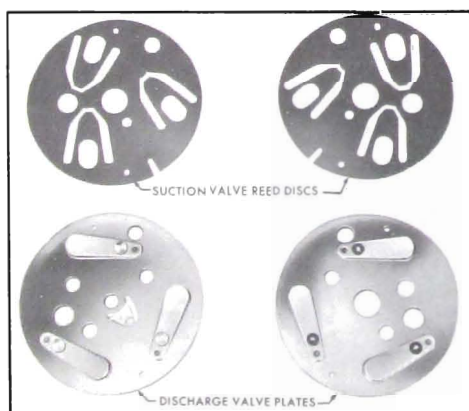

Figure 11-62—Suction Valve Reed Discs and Discharge Valve Plates

cylinder bearings. See Figure 11-63.

e. Thrust Bearings and Races

Two needle thrust bearings are seated around the shaft and are located near the center of the compressor. These bearings have rollers placed radially in their housing. Each bearing is "sandwiched" between two steel thrust races, and this combination of three pieces is placed between the shoulders of the swash plate and the shoulders of the cylinder hubs on the front and rear halves of the cylinder. See Figure 11-64.

The front end combination, consisting of a needle bearing with a selected thrust race on each side, provides the proper head clearance below the top of cylinder and the underside of the suction and discharge valve plates. See Figure 11-65.

The rear end combination, consisting of a needle bearing with a selected thrust race on each side, obtains a .005 to .0015 running clearance between the hub surfaces of the swash plate and the front and rear hubs of the cylinder.

f. Cylinder Block and Piston

The cylinder assembly consists of two halves, front and rear.

Alignment and register of the two halves are maintained by two locator (roll) pins. Cylinder block assemblies are only serviced in matched sets (front and rear halves).

The double end pistons are made of cast aluminum. Each piston has a notch cast in one end for identification purposes. This notched end of the piston is to be positioned toward the front end (pulley end) of the compressor.

Both ends of the pistons have a groove to receive a piston ring. Two oil return holes are drilled behind the ring groove and extend toward the center area of the piston to allow oil to drain to the compressor oil sump. The piston rings have an oil scraper groove at one edge to wipe any excess oil back into the oil sump (reservoir) through the oil return holes.

A spherical cavity is located in the inside center on each side of the pistons to receive the drive balls (see Figure 11-64).

g. Shoe Discs

Shoe discs are made of bronze and one side is a flat surface which contacts the surface of the swash plate. The opposite side has a coined concave surface into which is assembled the drive ball.

These shoes are provided in .005 inch increments and ten sizes are available for servicing these parts. Also, a basic zero shoe size is available for use during compressor rebuilding operations.

All service shoes will be marked with the shoe size, which will also correspond to the last three digits of the part number.

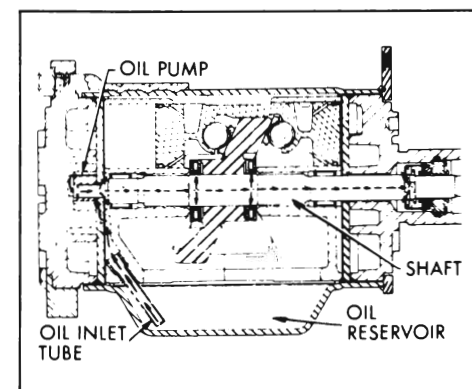

Figure 11-63—Oil Flow in Compressor

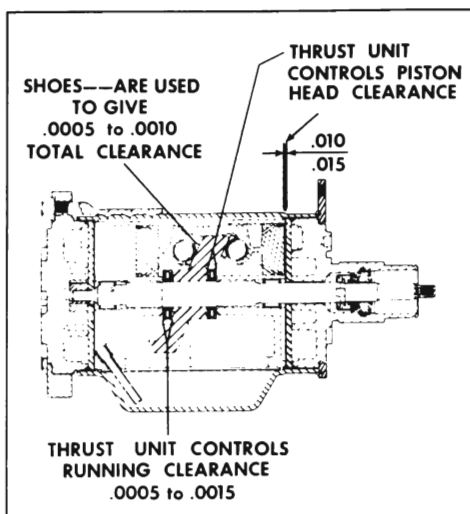

Figure 11-65—Compressor Internal Clearances

h. Swash Plate

An angular shaped member (swash plate) is located near the center of the compressor. The swash plate changes the rotating action of the shaft to provide a reciprocating driving force to each of the three pistons. This driving force is applied, through the shoes and balls, to the mid-point of each of the double end pistons. The swash plate has two angular faces ground smooth and parallel to permit smooth sliding of the shoe discs.

The plate is a press fit on to the drive shaft and is positioned by a Woodruff key. The swash plate and shaft are serviced only as an assembly.

i. Suction Pass Cover

Since the pistons are double-acting, low pressure vapor from the suction throttle valve must be supplied to both ends of the compressor and pistons.

The inlet (suction) port on the rear head of the compressor is connected by a hose to the outlet side of the suction throttle valve.

A fine mesh suction screen is located in the low pressure inlet cavity of the rear head. Its purpose is to trap any material that could damage the compressor mechanism. See Figure 11-66.

A flat rectangular cavity is cast into the outer face of the front and rear cylinders. The edges of this cavity are machined into a "dove-tail" shape to retain a rectangular suction pass cover with a neuphrene seal around its edges. This cover and seal form a passage for the low pressure vapor to flow from the rear head of the compressor to the front head and thus supply suction refrigerant to the pistons and cylinders at the front of the compressor.

j. Production Type Discharge Tube

The double-acting pistons produce a high pressure vapor at both ends of the compressor. The outlet (discharge) port for the high pressure vapor is located in the rear head of the compressor. See Figure 11-66.

A discharge vapor tube is used to connect the front head discharge cavity to the rear head discharge cavity. This tube has cylindrical ends that are spun into a hole in the front and rear cylinder head casting to provide a vapor tight joint. The center of this tube has a flattened mid-section to provide clearance between the swash plate and tube.

When the pistons in the front end of the cylinder are on their compression stroke, the high pressure vapor is caused to flow into the discharge cavity in the front head, through the discharge cavity. This vapor combines with the high pressure vapor produced by the pistons in the rear cylinder head during their compression

stroke and flows out the compressor discharge port.

k. Service Type Discharge Tube

The function and design of the service discharge tube are the same as that for the production type tube with the exception of shouldered sleeves located in both ends of the service tube. See Figure 11-67. These shoulders provide a surface for the "O"-rings and compression bushings. Since the production discharge tube is vapor sealed to the front and rear cylinder heads by "spinning in" the ends of the tube, equipment to perform this "spin in" operation during service operation would not be economical. Therefore, if it should be necessary to separate the cylinder halves during a service operation, a service type discharge tube should be used when reassembling the mechanism.

l. Pressure Relief Valve

The compressor is fitted with a high pressure relief valve. See

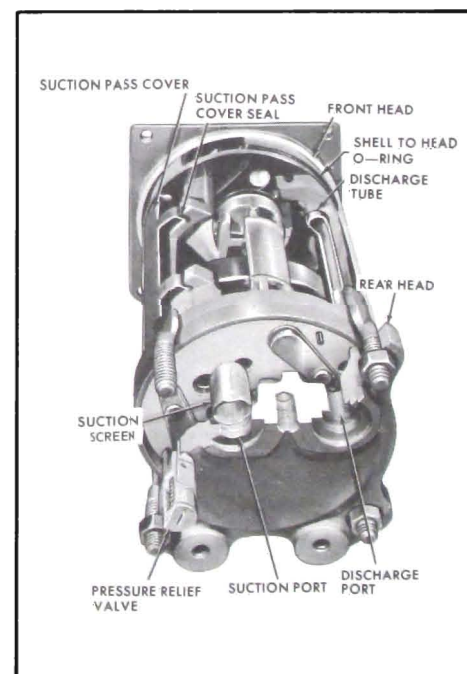

Figure 11-66—Compressor (Rear Cutaway View)

Figure 11-66. If the discharge pressure exceeds approximately 440 psi, the relief valve opens automatically to relieve the pressure and closes again when the pressure decreases.

Opening of the relief valve will be accompanied by a loud popping noise, and perhaps the ejection of some oil with the refrigerant. Any condition that causes this valve to open should be corrected immediately.

m. Oil Drain Screw

An oil drain screw is located on the under side of the compressor shell. This screw is used just for draining and adding oil. It is not an oil test outlet as the oil level cannot be checked while the compressor is installed on the engine due to the design of the compressor. It is not necessary to check compressor oil unless a large amount of oil has been lost. This could happen only with a sudden breaking of a line or some other serious break in system. If there has been a major loss of oil, the compressor should be removed and drained and oil added as outlined under Checking Compressor Oil and Adding Oil, paragraph 11-15, subparagraph "j".

n. Shell

The shell of the compressor has a mounting flange on the front end and four threaded screws welded to the outside at the rear. An oil sump is formed into the bottom of the shell with a baffle plate over the sump on the inside of the shell.

The compressor serial number is located on a plate on top of the compressor. This number should be included in all Product Information Reports, claims or correspondence concerning the

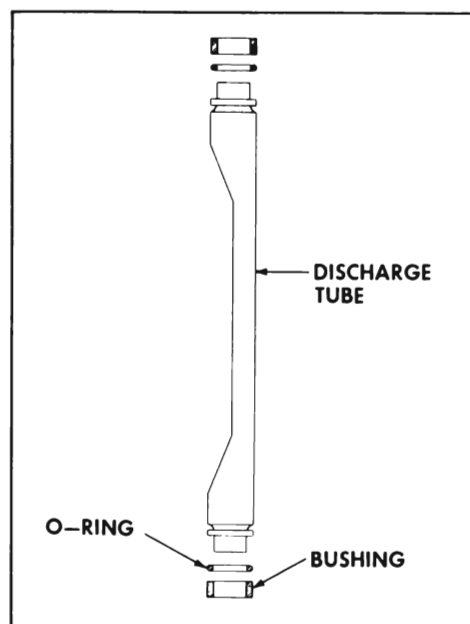

Figure 11-67—Service Type Discharge Tube

compressor. The compressor part number is also shown on the serial number plate.

o. Magnetic Clutch and Pulley Assembly

The pulley assembly contains an electrically controlled magnetic clutch, permitting the compressor to operate only when refrigerated air is desired.

When the compressor clutch is not engaged, the compressor shaft does not turn, although the pulley is still being turned by the compressor belts.

The clutch armature plate, which is the movable member of the clutch drive plate assembly, is attached to the assembly by means of flat springs. The hub of this assembly is pressed over the compressor shaft and is aligned with a square drive key located in the keyway of the compressor shaft. This clutch drive plate assembly is held in place with a nut. See Figures 11-68 and 11-69.

A two-row ball bearing is pressed into the hub of the pulley assembly and held in place by a bearing-to-pulley retainer wire. The pulley assembly and bearing is pressed over the front head of the compressor and held in place by a bearing-to-head retainer ring.

The coil and housing assembly has 3.85 ohms resistance at 80° F. (surrounding temperature) and should not demand more than 3.2 amperes at 12 volts D.C.

Three protrusions on the rear of the coil housing fit into alignment holes in the front head of the compressor. When the coil and housing assembly is aligned and engaged with the front head, it is secured in place by the coil and housing retainer ring. If removed, it is important that the coil and housing be reassembled in their original position so that the wiring harness connector may be plugged on the coil terminals.

When the air conditioner controls are set for cooling, current flowing through the coil creates a magnetic force which flows through the pulley to draw the armature plate rearward toward the pulley. As the armature plate moves toward the pulley, it contacts the pulley face.

The design of the clutch and coil is such that magnetic force locks the armature plate and pulley together as one unit. Since the armature plate hub is pressed on, and keyed to the compressor shaft, the shaft will then turn with the pulley.

When the air conditioner controls are turned off, the electric circuit to the compressor clutch is open and the magnetic pull on the clutch no longer exists.

The springs of the clutch drive plate assembly will then pull the

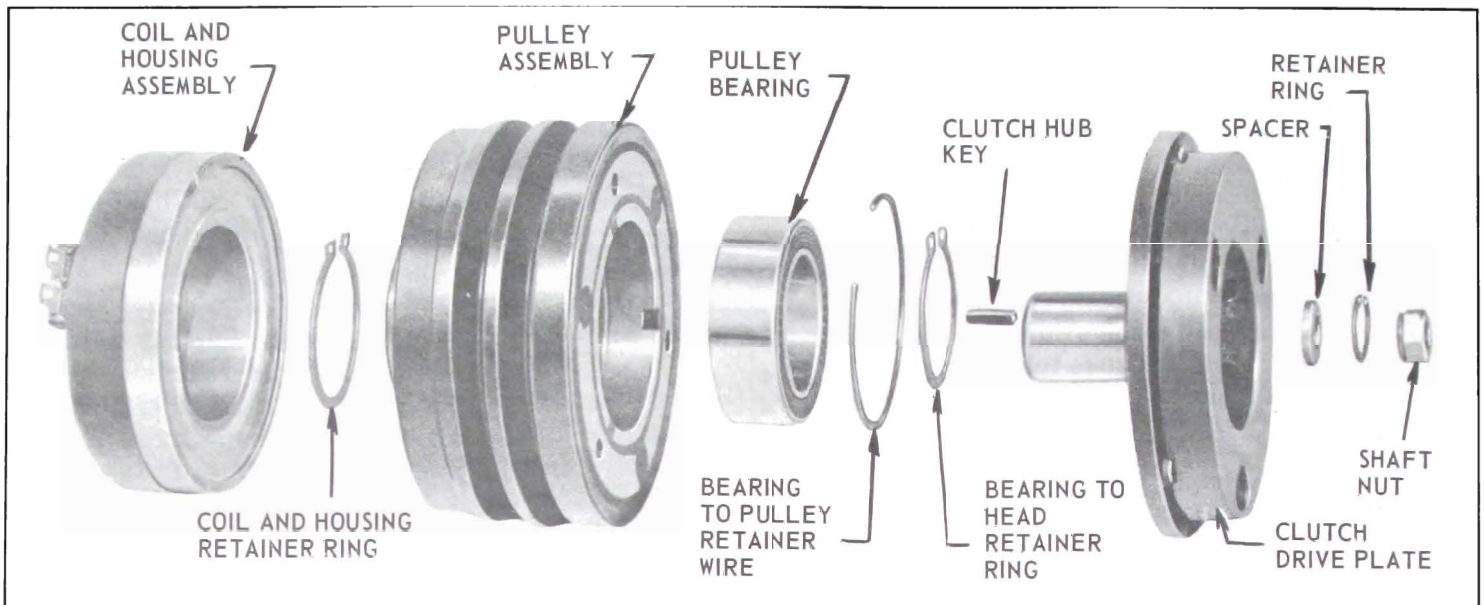

Figure 11-68—Compressor Magnetic Clutch Assembly - 46000, 48000 and 49000 Series

armature plate away from the pulley, and the plate loses contact with the pulley. With the clutch released, the pulley rotates freely on its bearing. In this condition, the compressor shaft does not rotate.

It may be noted that if the air

conditioning system was in use when the engine was turned off, the armature plate may remain in contact with the pulley assembly, due to residual magnetism. This will cause no trouble, as the armature plate and pulley will separate as soon as the engine is started.

p. Compressor Shaft Seal

A replaceable shaft seal is used at the front of the compressor to seal the air conditioning system from atmosphere when the compressor is operating or at rest, regardless of pressures in the compressor.

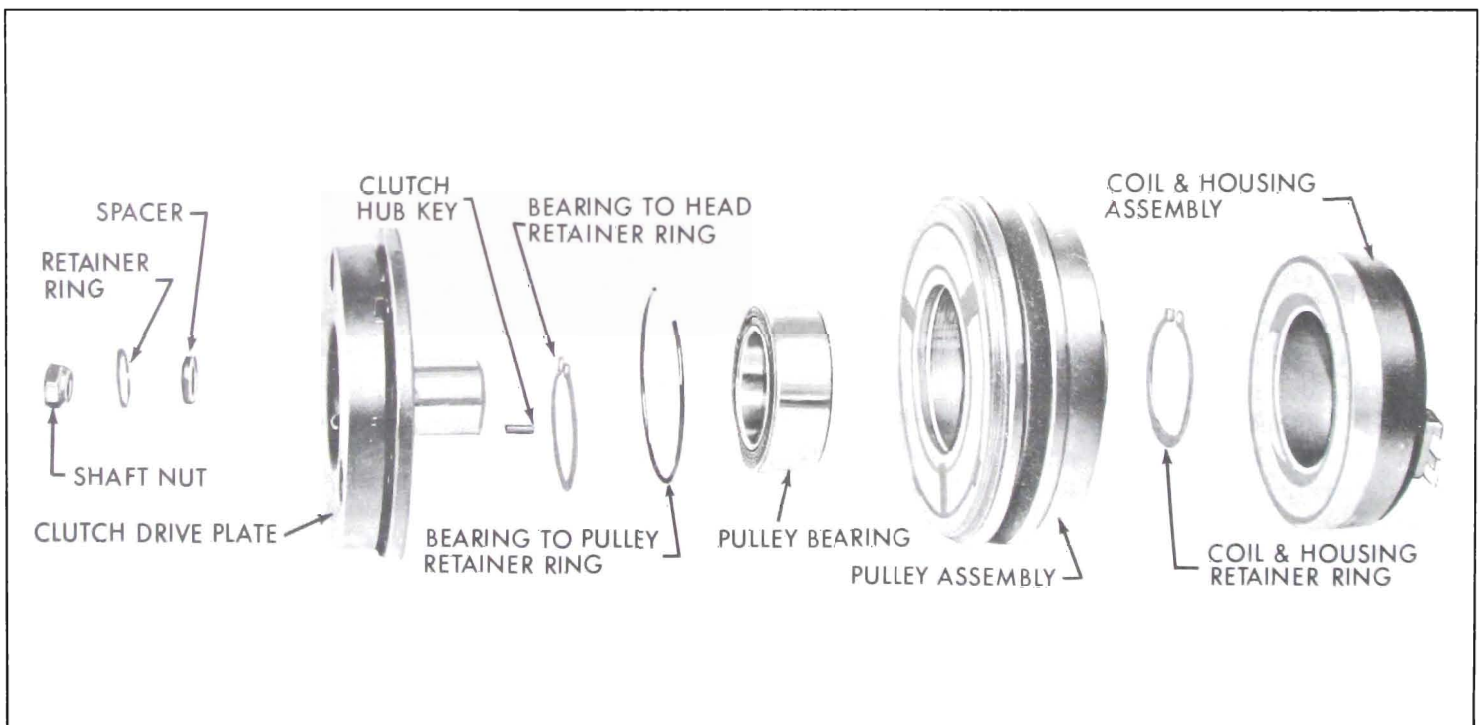

Figure 11-69—Compressor Magnetic Clutch Assembly - 45000 Series

Components of the seal located in the neck of the front head of the compressor are the seal seat retaining ring, the seal seat "O"-ring, the spring-loaded shaft seal and the cast iron shaft seal seat. The seal indexes with two flats machined on the compressor shaft and turns with the compressor shaft.

A spring in the shaft seal holds the seal against the seal seat which is held stationary in the neck of the compressor front head by the seal seat retainer ring.

Because of the constant pressures inside the compressor, this surface must be protected against damage, such as scratches and nicks (even finger markings may cause surface damage) to prevent oil and/or refrigerant leaks past this seal.

Shaft seal service parts are supplied in a complete kit containing all necessary replacement parts.

11-13 HEATER-AIR CONDITIONER CONTROLS AND AIR DISTRIBUTION SYSTEM—45000, 46000 AND 48000 SERIES

a. Heater-Air Conditioner Controls—45000, 46000 and 48000 Series

The controls for the 45000, 46000 and 48000 Series heater-air con-

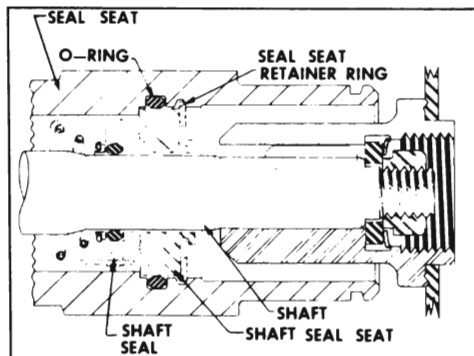

Figure 11-70—Shaft Seal Assembly

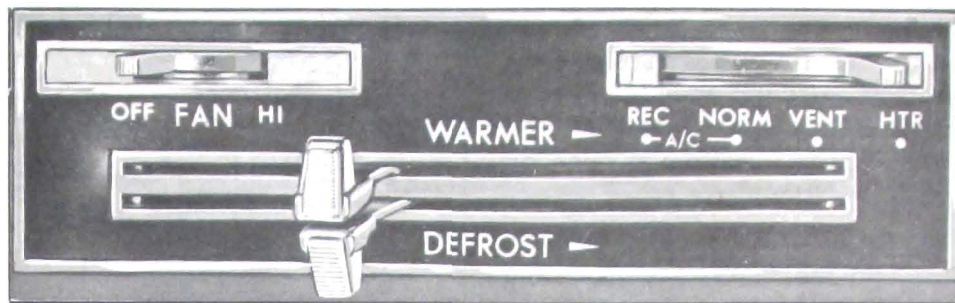

Figure 11-71—Air Conditioner-Heater Controls - 45000, 46000 and 48000 Series

ditioner consist of two switch levers and two slide levers (See Figure 11-81). These controls function as follows:

1. Climate Control Lever--This lever operates the Outside-Rec. and the Htr.-A/C vacuum disc switch. This switch in turn applies vacuum to the outside--recirculated air door vacuum diaphragm and the heater-air conditioner air door vacuum diaphragm. In addition the lever is mechanically linked to the compressor clutch control switch.

Movement of the lever actuates these components in the following sequence (refer to Figure 11-73). REC--At this position of the lever, the compressor clutch control switch is closed completing half the circuit of the compressor clutch (the FAN switch must also be closed before the compressor clutch will be energized). Vacuum is supplied to #2 port of outside-recirculated air door vacuum diaphragm. This causes the door to partially open thereby permitting the system to draw out and recirculate air inside the passenger compartment (see Figure 11-77).

NORM-- This position maintains the clutch compressor switch closed and applies vacuum to #1 port as well as #2 port of the outside-recirculated air door vacuum diaphragm. With vacuum applied to both ports of this vacuum diaphragm, the door opens completely thereby drawing on only outside air and blocking off

the recirculated air supply (see Figure 11-76).

VENT--In this position the compressing clutch control switch is open thereby disrupting half the electrical circuit of the compressor clutch. If the FAN switch was closed and the air conditioning system operating, the compressor would thus be shut off. Vacuum is maintained at #1 and #2 ports of the outside-recirculated air door vacuum diaphragm. The VENT position is provided so that the driver may have uncooled outside air from the air conditioner outlets.

HTR--In this position the clutch control switch remains de-energized and vacuum remains applied to #1 and #2 ports of the outside-recirculated air door vacuum diaphragm. In addition vacuum is applied to #1 port of the heater-air conditioner air door vacuum diaphragm. The door changes position and blocks off air flow to air conditioner outlets and directs air flow to heater floor outlets (see Figure 11-75).

2. FAN Lever. This lever operates the Heater & A/C Blower switch (see Figure 11-72). When this lever is moved from one extreme to the other, four stops will be felt. Moving from left to right, the 1st stop will provide low-low blower speed (provided the clutch control switch is closed). If the clutch control switch is open the blower will not

operate. The second, third and fourth detents respectively provide low, medium and high blower speeds regardless of whether the clutch control switch is open or closed.

The FAN lever is mechanically linked to the main vacuum switch (see Figure 11-78).

Whenever the FAN lever is away from OFF position vacuum is applied to #2 port of outside recirculated air door diaphragm and door is partially opened.

3. WARMER Lever --When this lever is positioned fully to the left vacuum is applied to the diaphragm of the suction throttling valve and the diaphragm of the water valve is vented. Under these conditions, when the air conditioner is operating, maximum refrigeration is provided. Initial movement of the lever to the right, vents the STV and thereby reduces the temperature of air conditioned air. When the system is not operating as an air conditioner, no effect is had. Simultaneously as the STV is vented, vacuum is applied to the diaphragm of the water valve and coolant from the engine is circulated thru the heater core. Further movement of the lever to the right opens the temperature door via a control cable attached to the lever. Regardless of the position of the Climate Control lever (REC, NORM, VENT or HTR) the air flow will be warmed proportionate with the travel of the lever to the right.

4. DEFROST Lever--This lever is connected to the defroster door

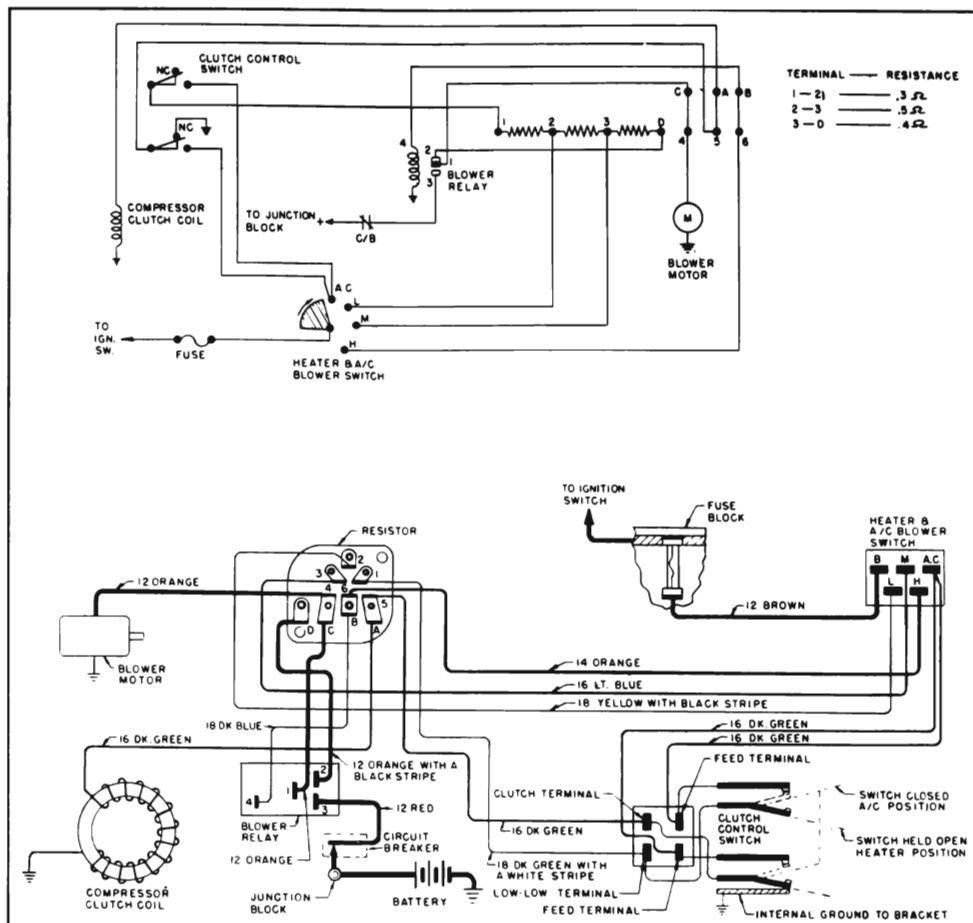

Figure 11-72—Heater-Air Conditioner Schematic - 45000, 46000 and 48000 Series

(see Figure 11-74) via a control cable. As the lever is moved to the right more and more air will be directed to the defroster outlets provided the system is operating in HTR mode of operation.

b. Trouble Diagnosis—45000, 46000 and 48000 Series

If the air conditioner-heater air

distribution system does not function properly, first check the vacuum hose connections and control wire adjustments. See Figure 11-78. If this does not correct, check for vacuum at vacuum diaphragms, for proper operation of vacuum switches and climate control. See Figures 11-74 through 11-77. Refer to following chart for other possible causes.

ACCESSORIES

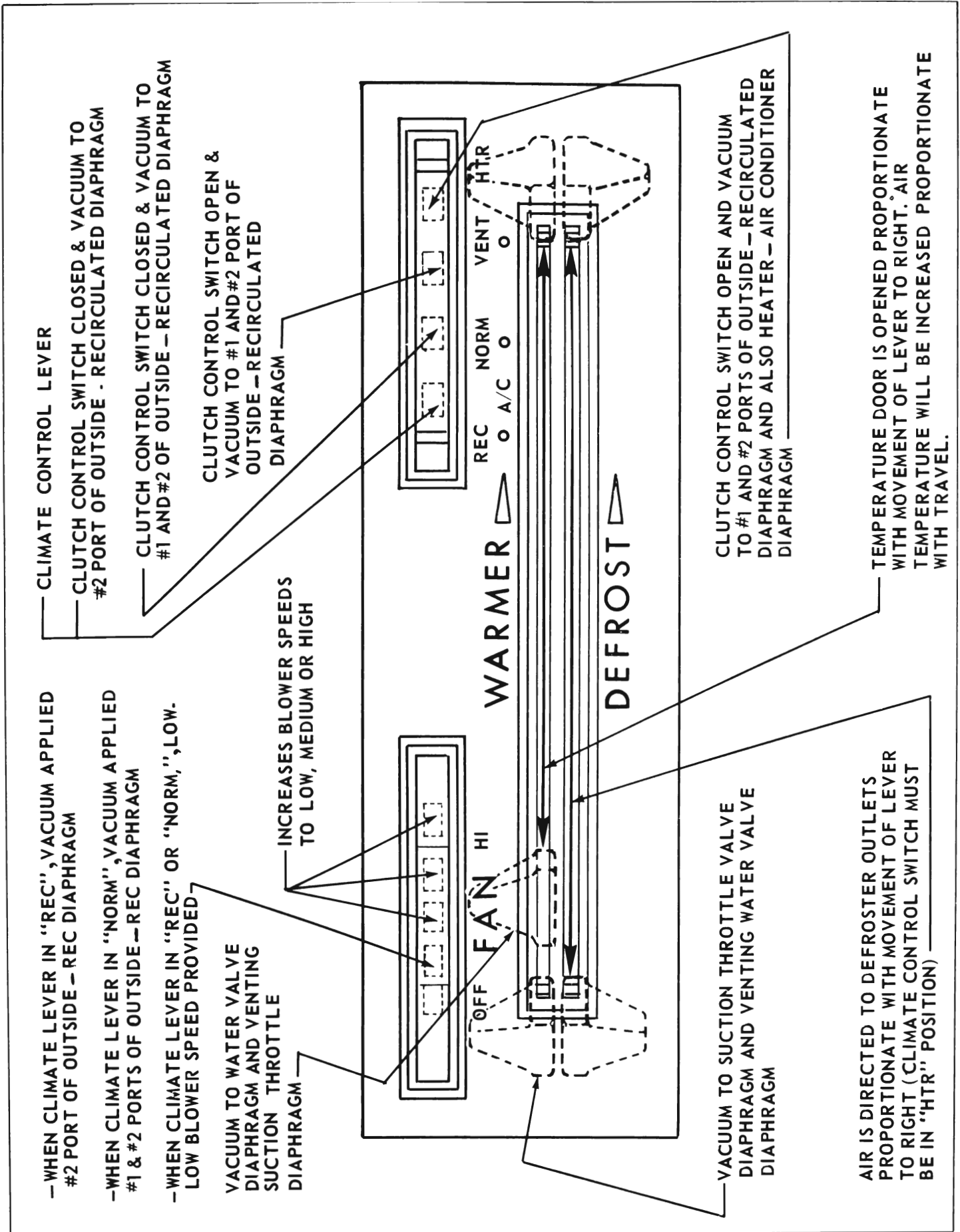

Figure 11-73—Sequence of Operation of Air Conditioning Control Assembly

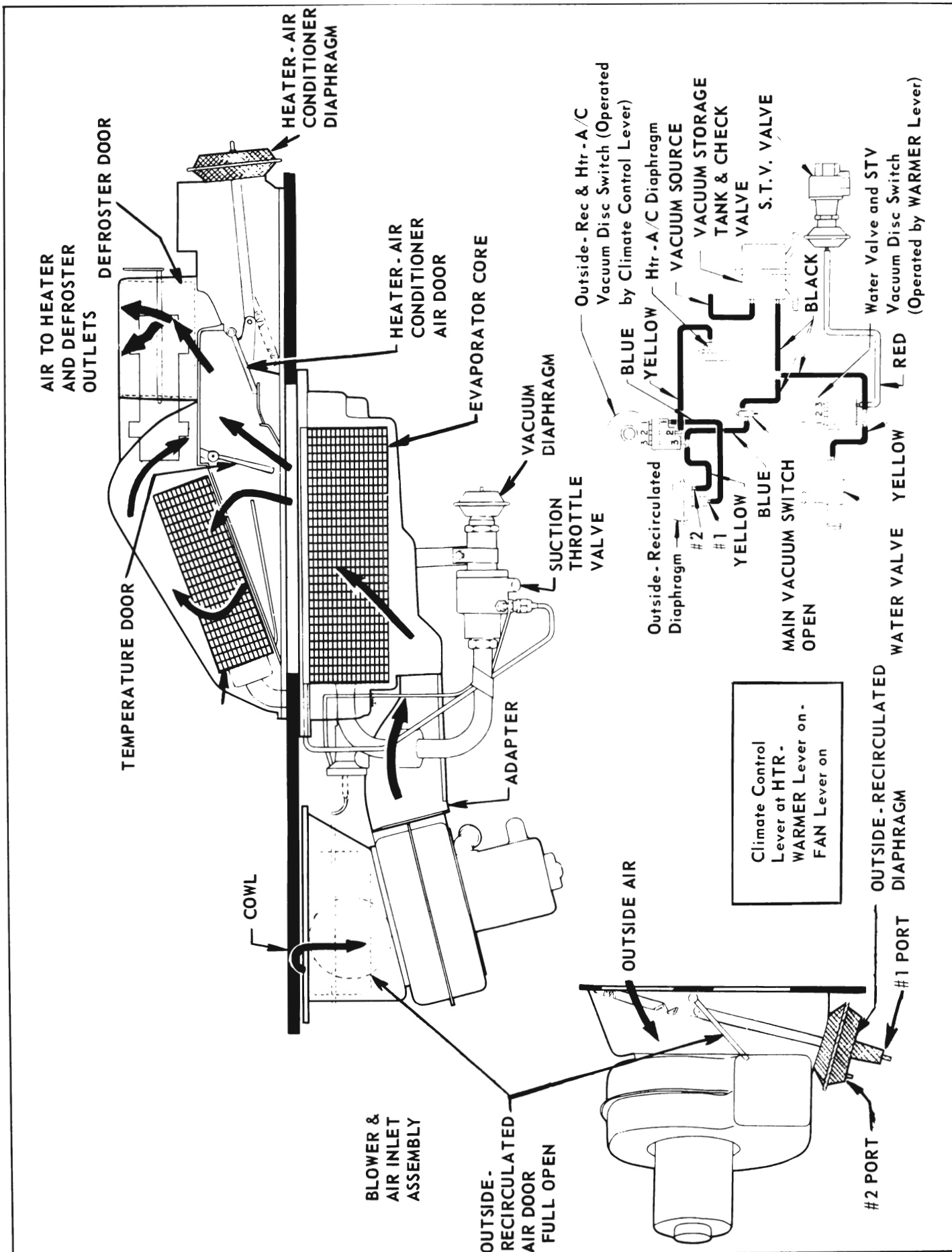

Figure 11-75—Air Conditioner Off, Heater On - 45000, 46000 and 48000 Series

ACCESSORIES

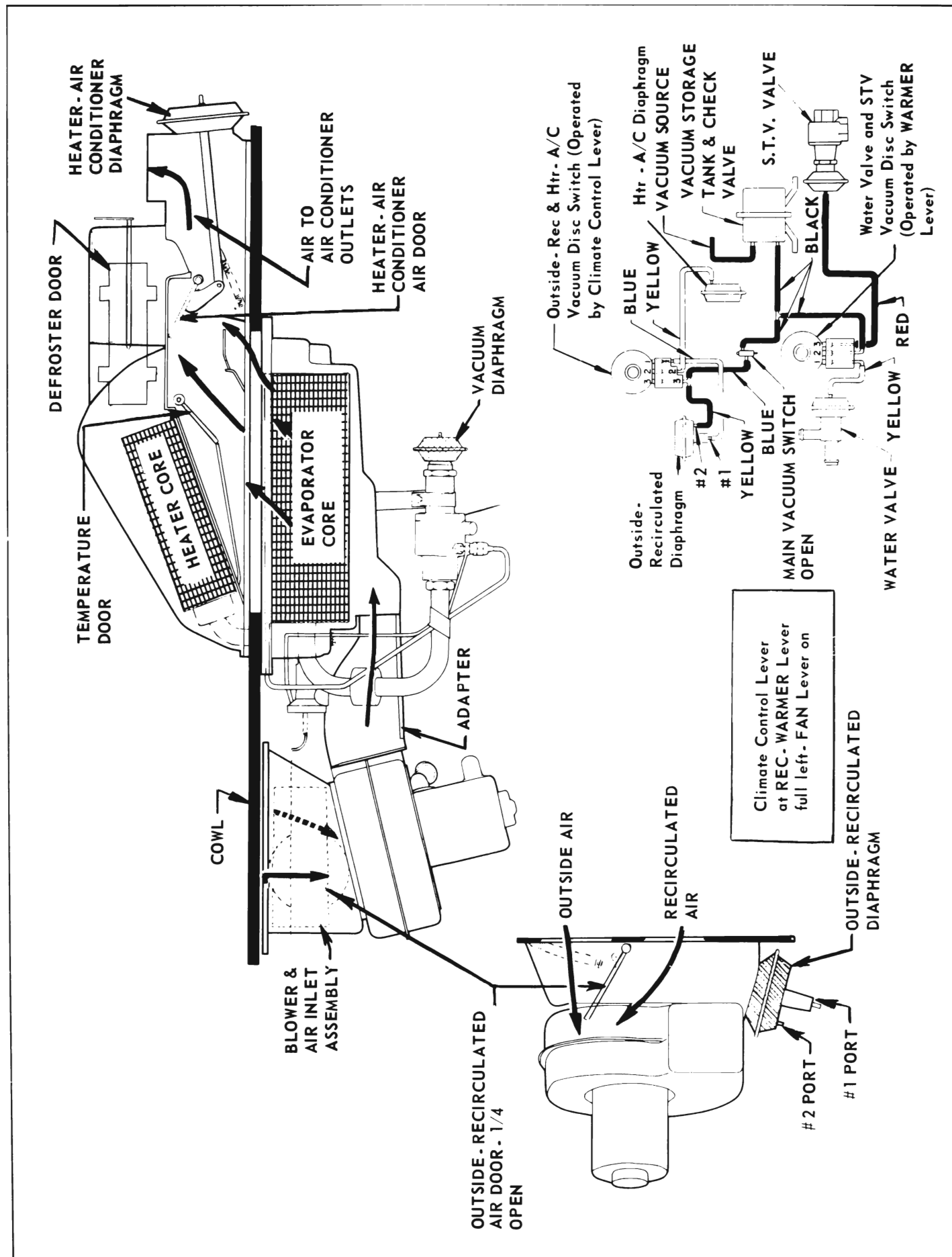

Figure 11-77—Air Conditioner Recirculate (Maximum) Heater Off - 45000, 46000 and 48000 Series

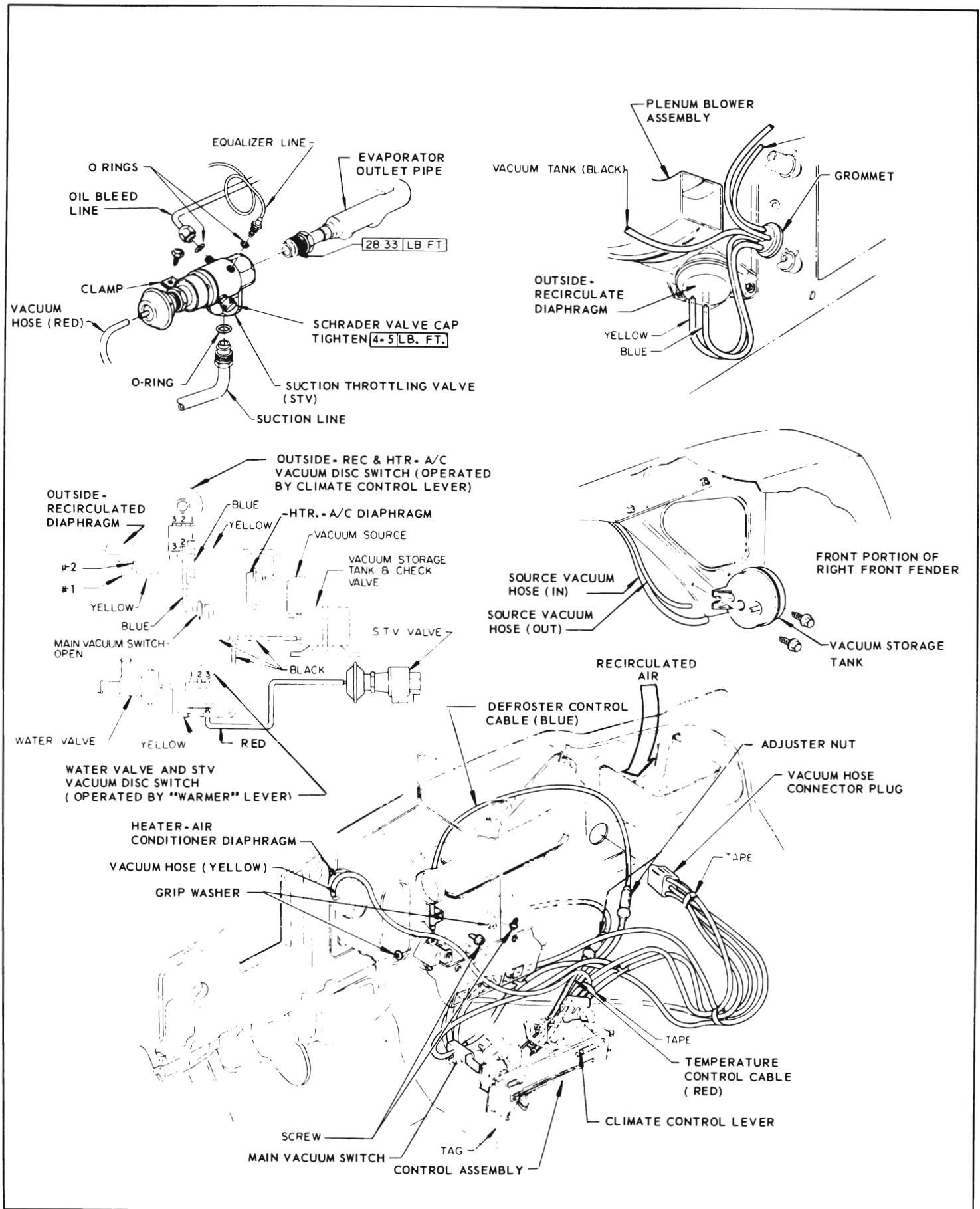

Figure 11-78—Vacuum Hose Installation - 45000, 46000 and 48000 Series

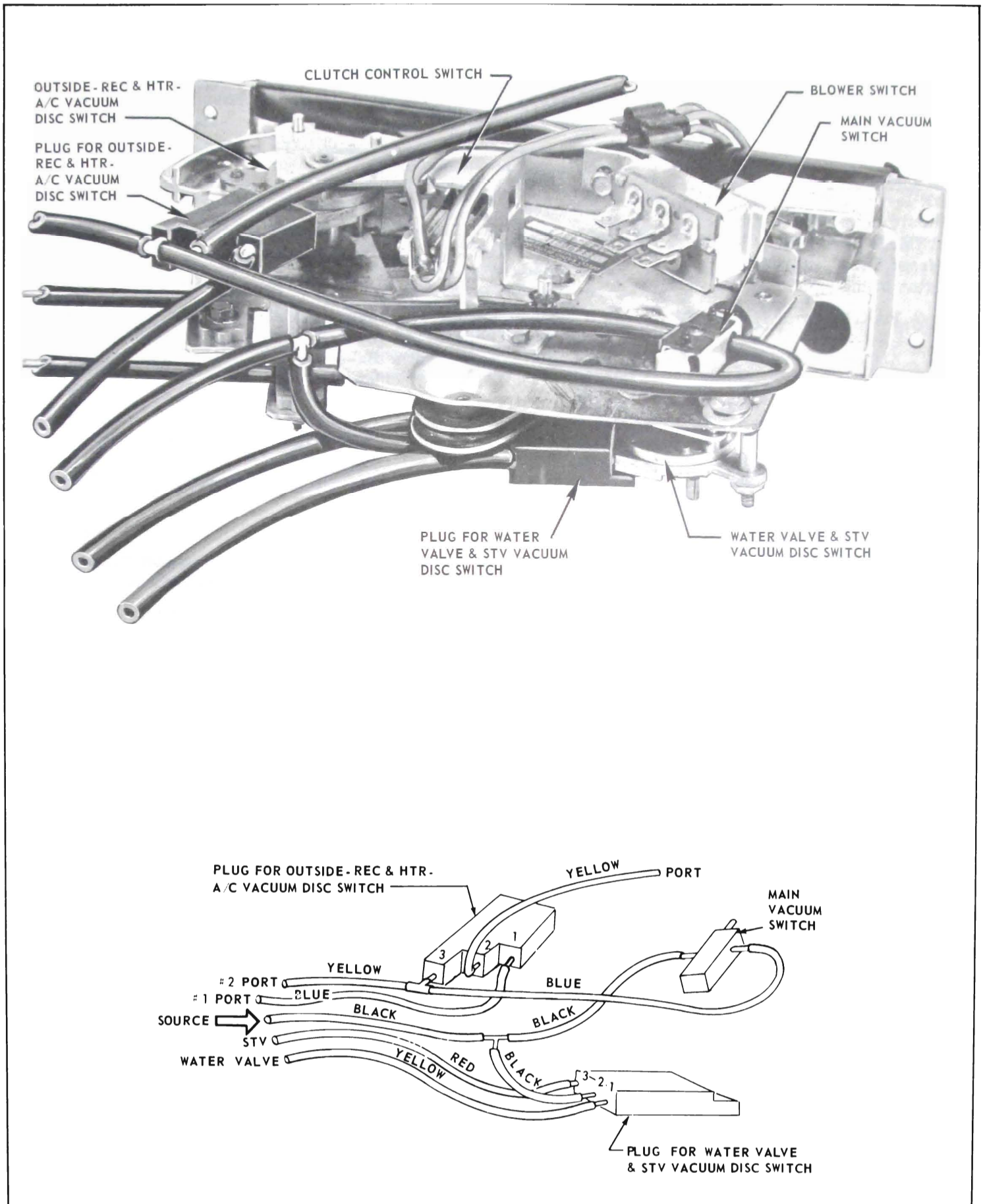

Figure 11-79—Vacuum Hose Installation at Rear of Control Assembly

c. Air Conditioning Checkout Sequence and Trouble
Diagnosis—45000, 46000 and 48000 Series

Sequence of Operation of Controls	Changes That Should Take Place in the System	Possible Cause of Malfunctions
<p>Pre Conditions— FAN lever—OFF Climate Control Lever-REC. WARMER Lever—fully left Defrost Lever—fully left Engine idling</p> <p>Move FAN lever to 1st detent.</p>	<p>Main vacuum switch will open and apply vacuum to #2 port of Outside-Recirculate diaphragm. Outside—Recirculate air door will open 1/4 of complete travel.</p> <p>Vacuum will be applied to diaphragm of STV.</p> <p>The blower will operate at low blower speed and air will flow from air conditioner outlets.</p>	<p>Kinked, plugged or disconnected hose.</p> <p>Outside - Rec. Diaphragm defective.</p> <p>Outside — Rec. Air Door sticking.</p> <p>Main vacuum switch defective or misadjusted.</p> <p>Defective vacuum storage tank.</p> <p>Vacuum hoses on wrong ports on vacuum diaphragm.</p> <p>Vacuum hoses incorrectly assembled to connector plug on cowl.</p> <p>Kinked vacuum hoses.</p> <p>Defective water valve and STV vacuum disc switch.</p> <p>Defective or misadjusted clutch control switch.</p> <p>Defective resistor assembly.</p> <p>Defective blower motor.</p> <p>Defective wire.</p> <p>Fuse</p> <p>Defective blower switch.</p> <p><u>NOTE: If only one blower available regardless of switch position, it is likely resistor assembly coils are touching.</u></p> <p><u>NOTE: If air flows from the heater outlets, or flows from both the heater and the A/C outlets it is possible that the spring which holds the door in position is broken.</u></p>

**c. Air Conditioning Checkout Sequence and Trouble
Diagnosis—45000, 46000 and 48000 Series (Cont'd)**

Sequence of Operation of Controls	Changes That Should Take Place in the System	Possible Cause of Malfunctions
<p>Move FAN lever to 1st detent. (Con't.)</p>	<p>The compressor clutch will engage.</p>	<p>Defective or misadjusted clutch control switch.</p> <p>Loose or broken wire.</p> <p>Defective compressor clutch coil.</p> <p>Compressor clutch ground wire broken.</p> <p>Connector loose at compressor coil.</p> <p><u>NOTE: If neither the blower motor nor the compressor can be actuated-check the fuse and the blower switch.</u></p>
<p>Move the FAN lever thru 2nd, 3rd and 4th detents.</p>	<p>Blower will increase speed to low, medium and high.</p>	<p>Defective blower resistor assembly (coils touching).</p> <p>Defective blower switch.</p> <p><u>NOTE: If no high blower speed, check blower relay.</u></p>
<p>Move Climate Control lever to NORM.</p>	<p>Vacuum will be applied to #1 port of Outside-Rec. diaphragm thereby fully opening door.</p>	<p>Kinked hose.</p> <p>Outside - Rec. Diaphragm defective.</p> <p>Outside-Rec. door sticking.</p> <p>Outside - Rec. & Htr.-A/C vacuum disc switch defective.</p>
<p>Move Climate Control to VENT.</p>	<p>Compressor clutch will disengage.</p>	<p>Defective or misadjusted clutch control switch.</p> <p>Defective wiring.</p>
<p>Move Climate Control to HTR.</p>	<p>Vacuum will be applied to Htr.-A/C diaphragm and door will reposition directing air out of heater outlets.</p>	<p>Kinked or pinched hoses.</p> <p>Htr.-A/C diaphragm defective.</p> <p>Outside-Rec. & Htr.-A/C vacuum disc switch defective.</p> <p>Sticking Htr.-A/C door.</p> <p>Disconnected or misconnected hoses at connector plug on cowl.</p>

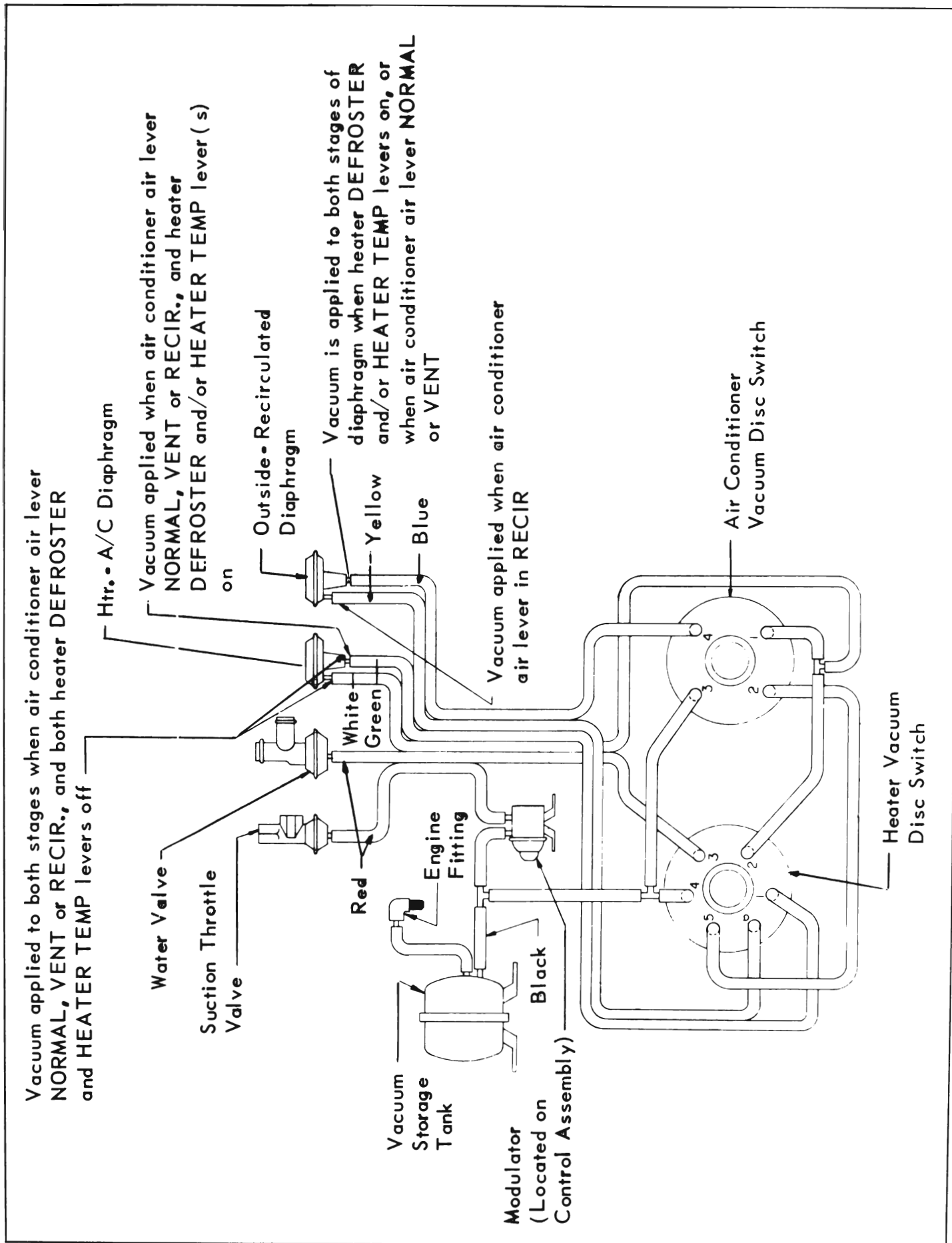

Figure 11-80—Vacuum Circuit - 49000 Series

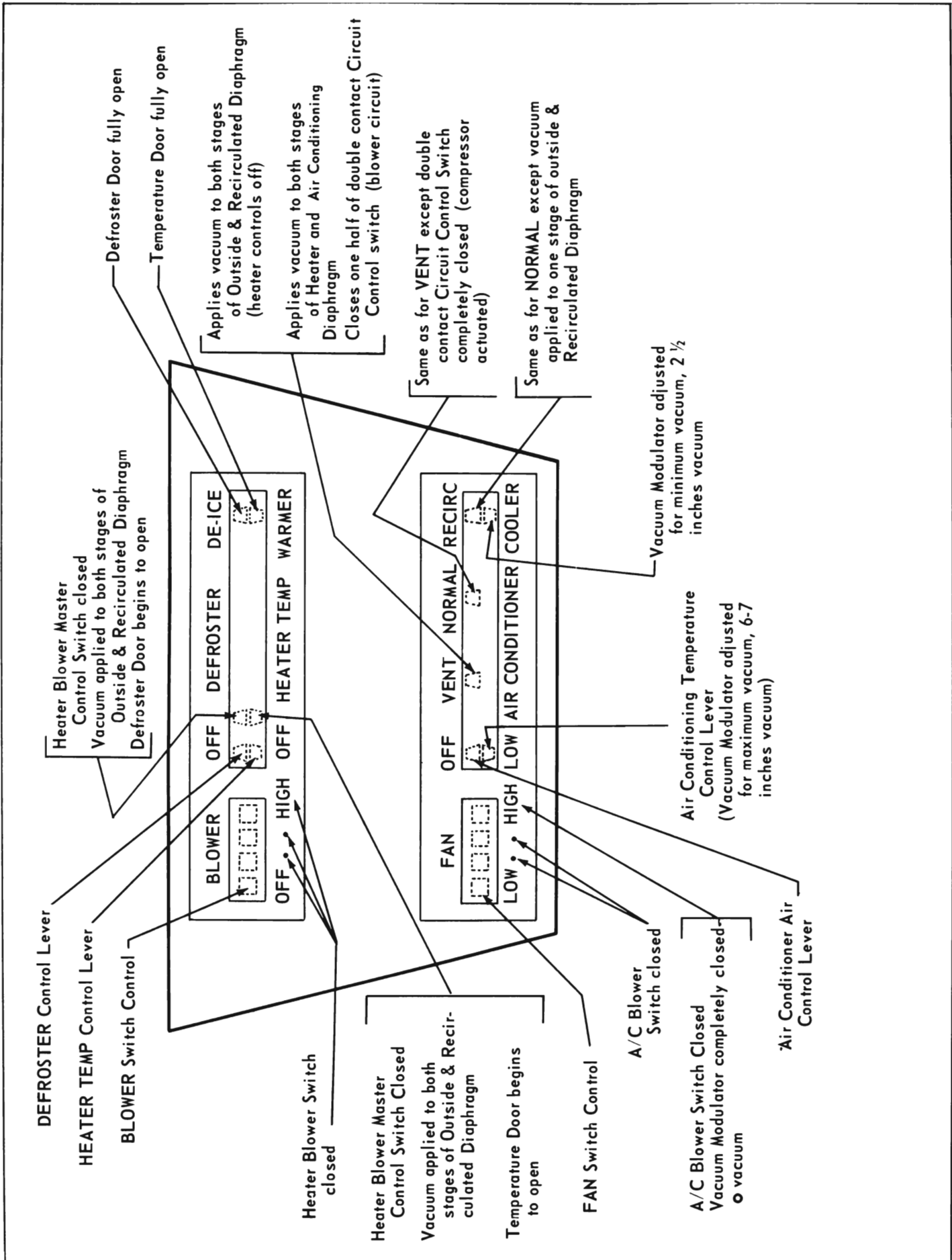

Figure 11-81—Air Conditioner Control Assembly Operation Sequence - 49000 Series

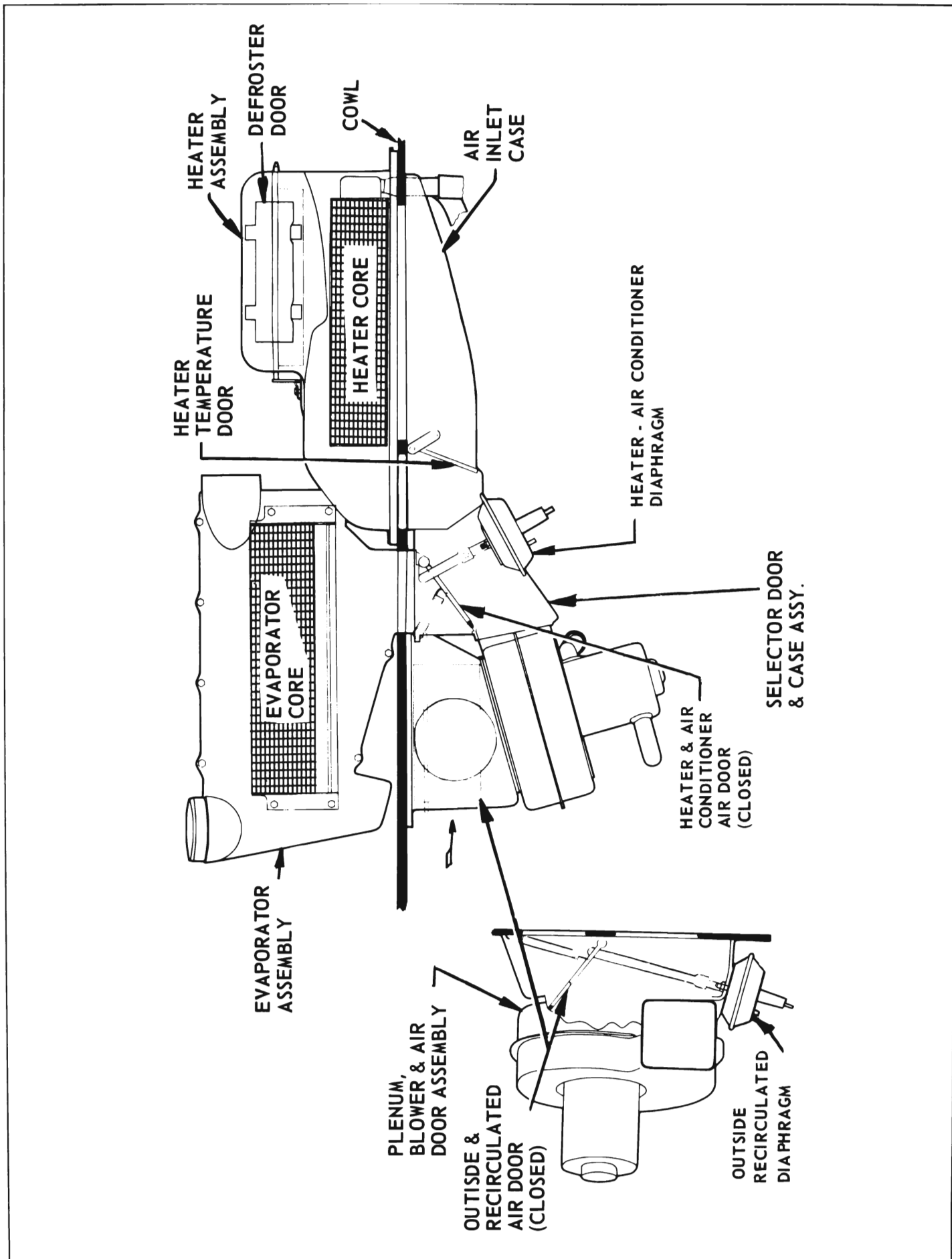

Figure 11-82—Air Conditioner and Heater Off - 49000 Series

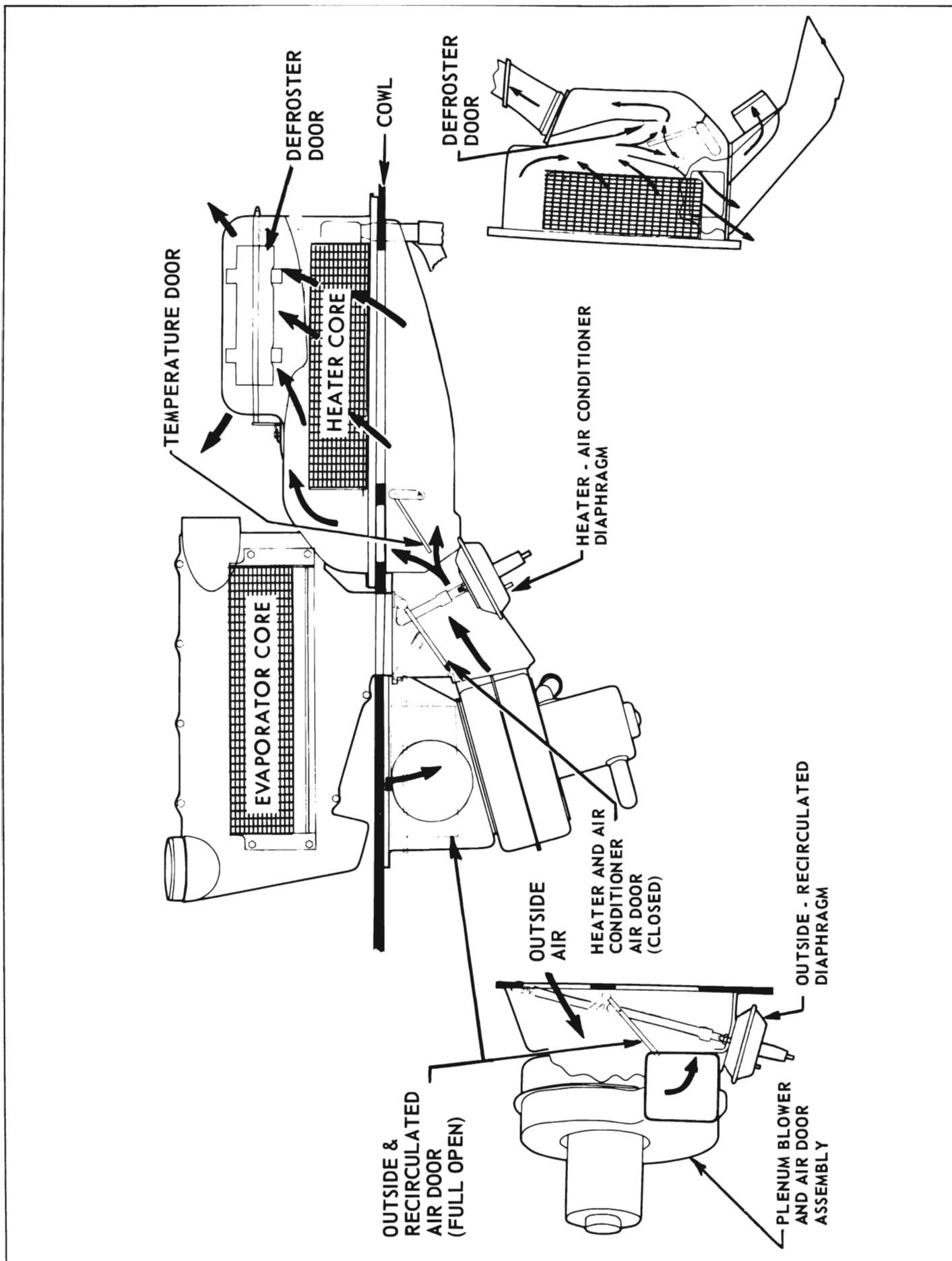

Figure 11-83—Air Conditioner Off, Heater On - 49000 Series

ACCESSORIES

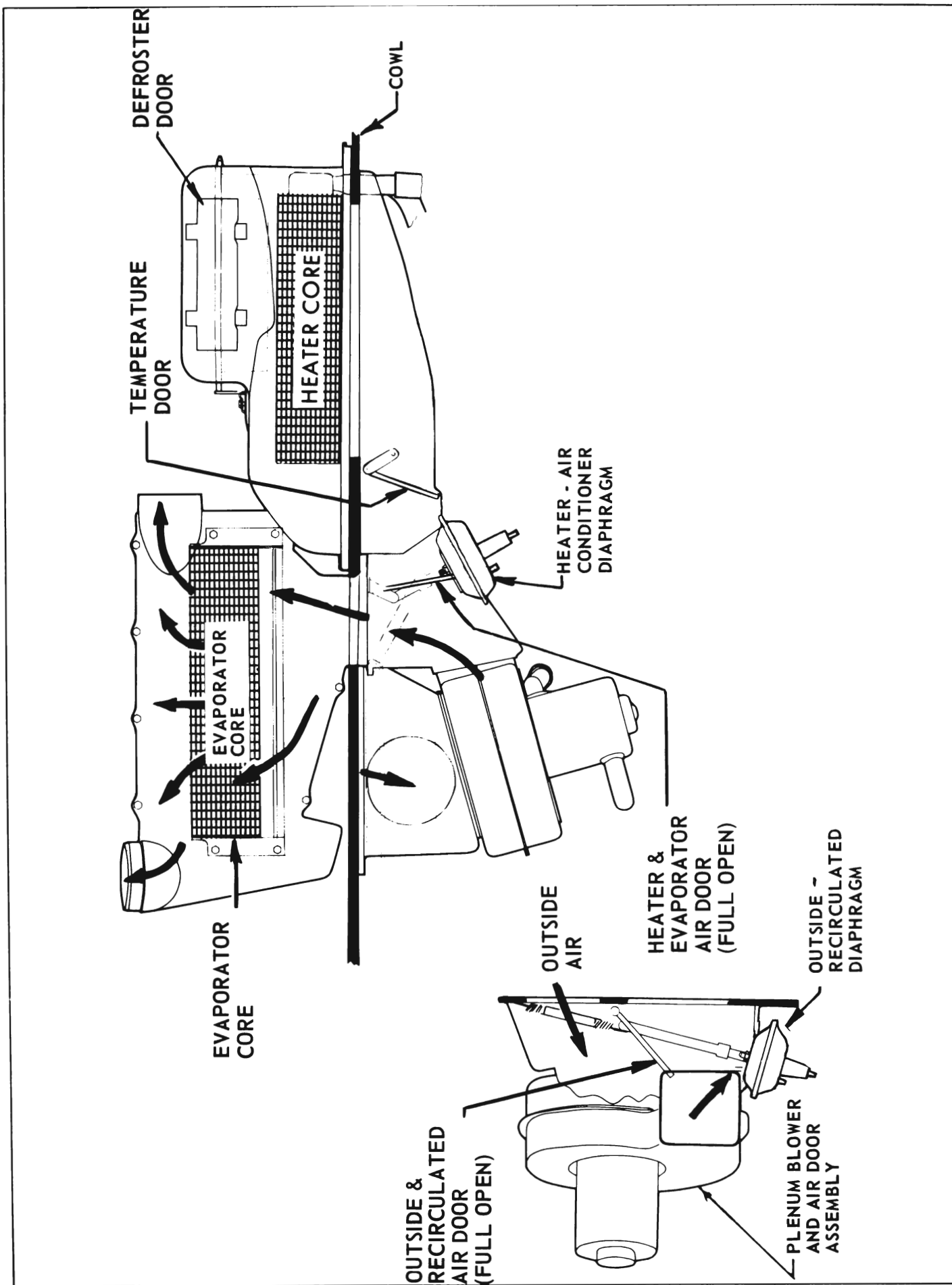

Figure 11-84—Air Conditioner Ventilation or Normal, Heater Off - 49000 Series

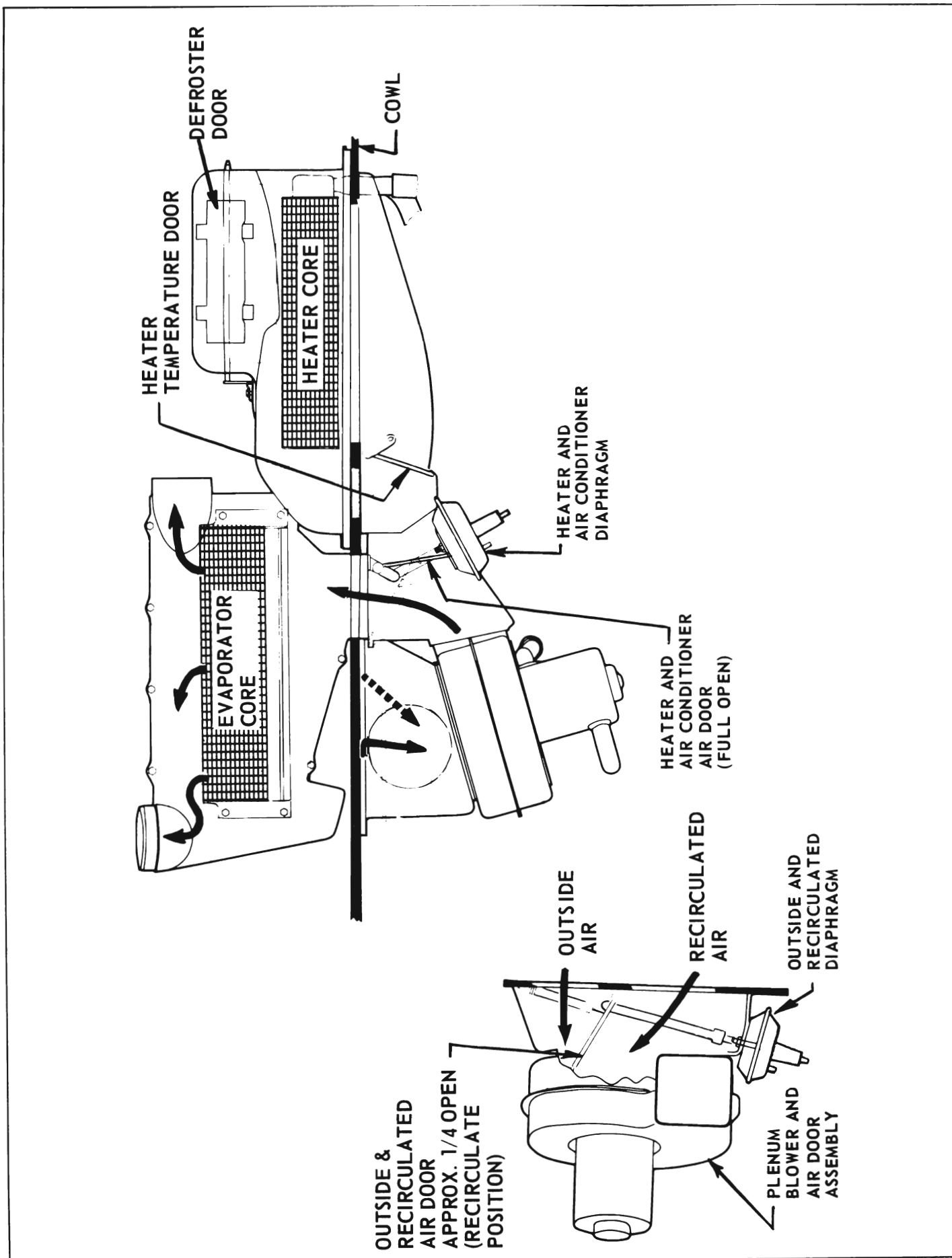

Figure 11-85—Air Conditioner Recirculate, Heater Off - 49000 Series

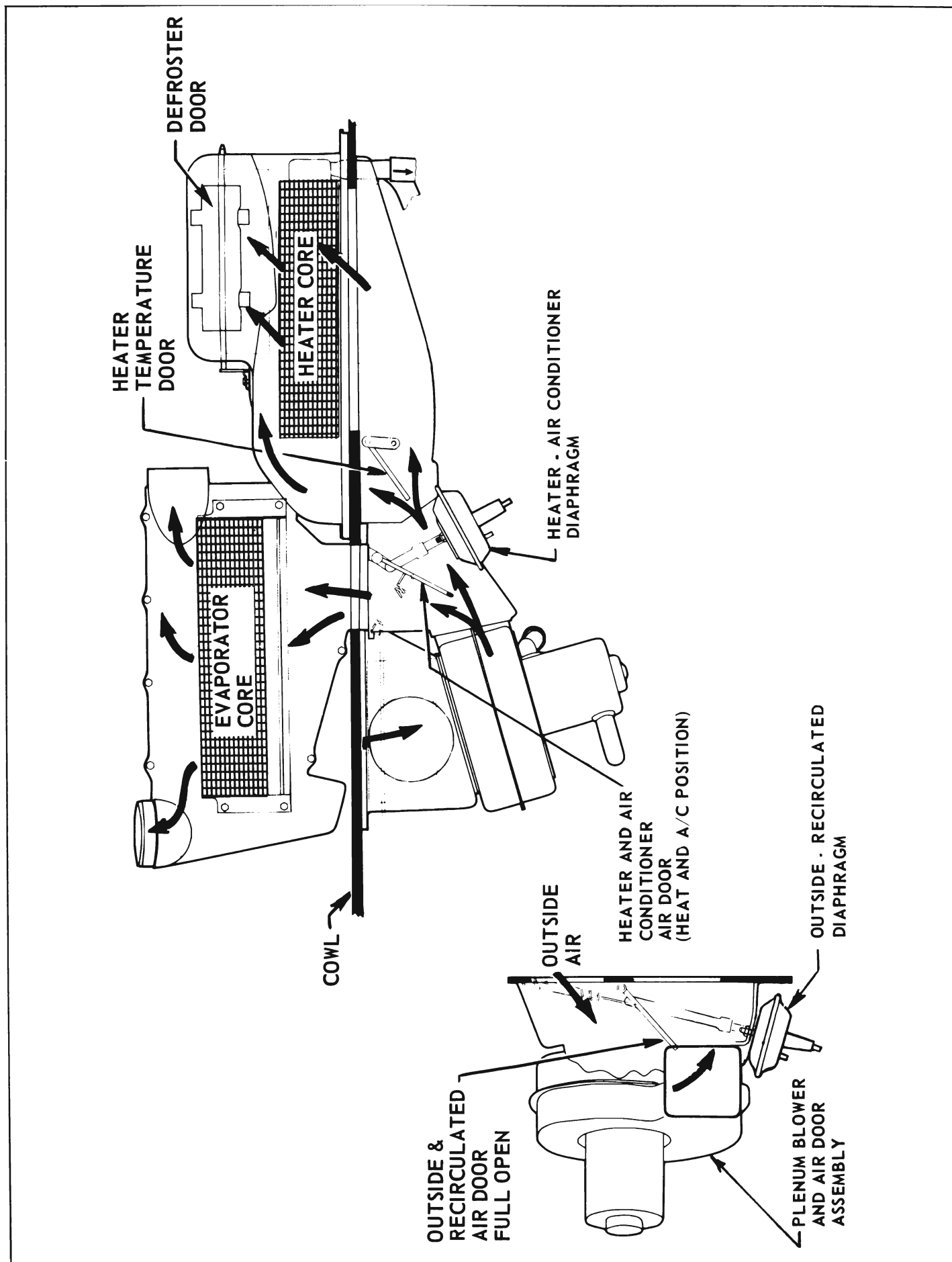

Figure 11-86—Air Conditioner Ventilation or Normal, Heater On - 49000 Series

c. Vacuum Switch Trouble Diagnosis—49000 Series

CONDITION	COMPLAINT	POSSIBLE CAUSE
All controls off.	Air out of A/C outlets. Air out of heater outlets.	Check heater and evaporator air door dual stage vacuum diaphragm. No vacuum should be present. Check outside and recirculated air door dual stage vacuum diaphragm. No vacuum should be present.
Air Conditioner Air Control Lever on.	Recirculated air only - no outside air, windows steam up, air in car stale. Air out of heater.	Check outside and recirculated air door vacuum diaphragm. Vacuum should be applied to one or both stages depending on position of lever. Check that vacuum is applied to both stages of heater and evaporator air door vacuum diaphragm.
Air Conditioner Air Control Lever on NORMAL and Air Conditioner Temperature Control Lever on DEFROSTER and HEATER TEMP levers OFF.	All air out of heater outlets. Both recirculated and outside air. Air out of A/C and heater outlets.	No vacuum applied to both stages of heater and evaporator air door vacuum diaphragm. Heater and evaporator air door stuck closed. Vacuum applied to only one stage of outside and recirculated air door vacuum diaphragm. Check for defective heater vacuum disc switch.
Air Conditioner Air Control Lever on RECIRC.	No recirculated air.	Defective air conditioner vacuum disc switch.
Air Conditioner Air Control lever RECIRC and DEFROSTER and/or HEATER TEMP Control Levers on.	All air through heater outlets. All air through A/C outlets.	Check for defective vacuum diaphragm. Check for defective heater vacuum disc switch.

11-15 SERVICE PROCEDURES

IMPORTANT: If a receiver-dehydrator is replaced, the port of the receiver-dehydrator marked "IN" must be attached to condenser outlet.

NOTE: See paragraphs 11-16 and 11-17 for service procedures on compressor assembly.

a. Safety Precautions

The following safety precautions should always be used when servicing the air conditioner refrigeration system.

1. Do not leave drum of Refrigerant-12 uncapped.
2. Do not carry drum in passenger compartment of car.
3. Do not subject drum to high temperature.
4. Do not weld or steam clean near system.
5. Do not fill drum completely.
6. Do not discharge refrigerant vapor into area where flame is exposed, or do not discharge directly into engine air intake.
7. Do not expose eyes to liquid refrigerant; always wear safety goggles.

b. Installation Precautions

1. All subassemblies are shipped sealed and dehydrated. They are to remain sealed until just prior to making connections.
2. All subassemblies should be at room temperature before uncapping. This prevents condensation of moisture from air that enters the system.
3. All precautions should be taken to prevent damage to fittings or connections. Even minute damage to a connection could cause it to leak.

4. Any fittings with grease or dirt on them should be wiped clean with a cloth dipped in alcohol. Do not clean fittings or hoses with chlorinated salts such as trichlorethylene, as they are contaminants. If dirt, grease or moisture gets inside the pipes and cannot be removed, the pipe is to be replaced.

5. Use a small amount of refrigeration oil on all tube and hose joints and lubricate the "O" ring seal in this oil before assembling the joint as this oil will help in making a leakproof joint. When tightening joints, use a second wrench to hold the stationary part of the connection to prevent twisting, and to prevent hose kinking as kinked hoses are apt to transmit noise and vibration.

CAUTION: Tighten all connections in accordance with recommended torques. See pipe and hose connection chart. See Figure 11-47. Insufficient torque when tightening can result in loose joints. Over-tightening can result in distorted joint parts, and either condition can result in refrigerant leakage.

6. Do not connect receiver-dehydrator assembly until all other seals of assemblies have been connected. This is necessary to insure optimum dehydration and maximum moisture protection of the system.

c. Discharging Refrigerant From Air Conditioner System

NOTE: When a part is removed or disconnected that is in the Air Conditioner refrigeration circuit, the refrigerant must be discharged from system using the following procedure.

1. Remove protective caps from Schrader valve gauge fittings on suction throttle valve and discharge line located at rear of compressor.

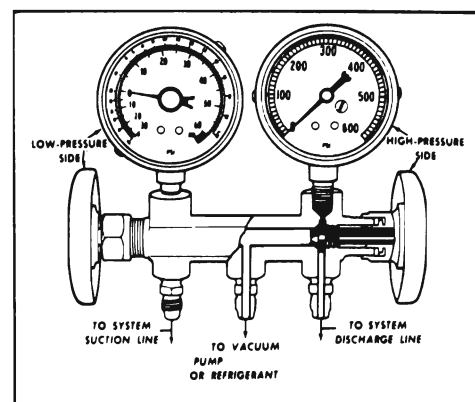

Figure 11-87—Manifold and Gauge Set, J-5725-01

2. Using Adapters J-5420, connect charging lines of pressure gauge and set Manifold and Gauge Set J-5725-01 (see Figure 11-87) to Schrader valves as shown in Figure 11-153 with both valves of manifold closed.

3. Slowly open valves on manifold and discharge all pressure from system.

CAUTION: Do not open valves too fast as excessive oil will be blown out of system. Place rag over end of discharge service line to prevent oil or liquid refrigerant from spraying on car or person.

d. Adjustments—45000, 46000 and 48000 Series

There is no service adjustment on the blower switch, the expansion valve, or the vacuum disc switches.

1. Temperature and Defroster Control Wire Adjustment - The air conditioner - heater wires are adjusted by rotating the adjuster nuts which are part of the control wire assembly.

To adjust any of the control wires, set control levers in off position. Then rotate the adjuster so that the lever on instrument panel has 1/8 to 3/16" spring-back from full off position.

IMPORTANT: Always recheck adjustment working lever back and forth thru travel.

2. Main Vacuum Switch Adjustment - Place FAN lever in off position. Loosen main vacuum switch attaching screws and push switch against control lever on circuit control assembly to fully depress plunger. Tighten mounting screws. See Figure 11-89.

3. Compressor Clutch Control Switch Adjustment -- Loosen screws securing switch to control assembly. Place Climate Control lever in VENT position and push switch against cam of lever until it clicks open. Secure in position. Move lever between NORM and VENT positions and listen for and observe both contacts of clutch control switch opening. Switch must be fully open by time lever in VENT position.

e. Adjustments—49000 Series

There is no service adjustment on the blower switches, the expansion valve vacuum modulator, vacuum diaphragms or vacuum disc switches on 49000 Series cars.

Adjustments for the control wires attached to the heater control assembly are the same as for non-air conditioned cars (ref. to par. 11-8 and see Figure 11-42).

f. Suction Throttle Valve Adjustments

IMPORTANT: The suction throttle valve adjustment is to be made only after the functional test shows evaporator pressure significantly different from the chart.

1. Have a service gauge set connected to Schrader valves as shown in Figure 11-153.

2. Set controls for maximum cooling, heater off, ventilators closed and all air conditioner outlets open.

(a) On 45000, 46000 and 48000 Series the climate control is set at

REC, the WARMER lever fully left and the FAN on HI.

(b) On 49000 Series the Air Conditioned Air Control, Temperature Control, and Fan switch levers are set full on. Heater Temp and Defroster levers are set to OFF.

3. Engine set at 2000 RPM.

4. Remove the vacuum hose from the 49000 suction throttle vacuum diaphragm. Do not remove hose from the 45000, 46000 and 48000 diaphragm.

5. Three minutes after the valve has started to control, check the gauge readings and outlet temperature against the functional test chart.

6. If necessary to adjust STV, loosen the large lock nut on sleeve of suction throttle valve vacuum diaphragm.

7. To adjust valve, rotate diaphragm assembly clockwise to increase evaporator pressure and counterclockwise to decrease pressure.

8. After adjusting the valve, observe operation of the system for a few minutes to check readings.

9. Tighten lock nut on sleeve and reinstall the vacuum hose on the 49000 vacuum diaphragm.

10. Check operation of suction throttle valve.

(a) On 45000, 46000 and 48000 Series, move the WARMER lever a short distance forward from the off position. There should be no vacuum to the vacuum diaphragm of the valve.

With the WARMER lever in this position, the evaporator pressure should raise by approximately three psi. If the evaporator pressure does not increase, check the water valve and STV vacuum disc switch, improper vacuum hose connections or kinked vacuum hoses. If these are correct, the

suction throttle valve is defective and should be repaired.

(b) On 49000 Series, move the Air Conditioner Air Control lever to normal position and the temperature control and Fan switch levers to Low.

With the levers in this position, the evaporator should raise to approximately 50 psi. Return the levers to full on and recheck setting of the suction throttle valve

If the 49000 evaporator pressure does not increase when Air Conditioning Temperature Control and Fan lever are at Low, check operation of vacuum modulator by connecting a vacuum gauge to the hose that goes to the STV. The modulator should regulate manifold vacuum from 6 to 7 inches when the temperature control lever is moved from the Low position to 0 inches when the temperature control and Fan switch levers are respectively in the cooler and high position. If modulator does not function properly, check vacuum hose connections, check for kinked hose or for defective modulator.

g. Removal and Installation of Suction Throttle Valve

1. Discharge refrigerant from system as described in subparagraph "c".

2. Disconnect lines from valve.

3. Remove valve mounting screws and remove valve.

NOTE: All of the openings to the air conditioning system should be capped or plugged during the time the STV is removed.

4. Install valve by reversing procedure for removal, paying attention to the following:

(a) Install new "O" rings on line fittings.

(b) The valve piston must be lubricated with 525 compressor oil

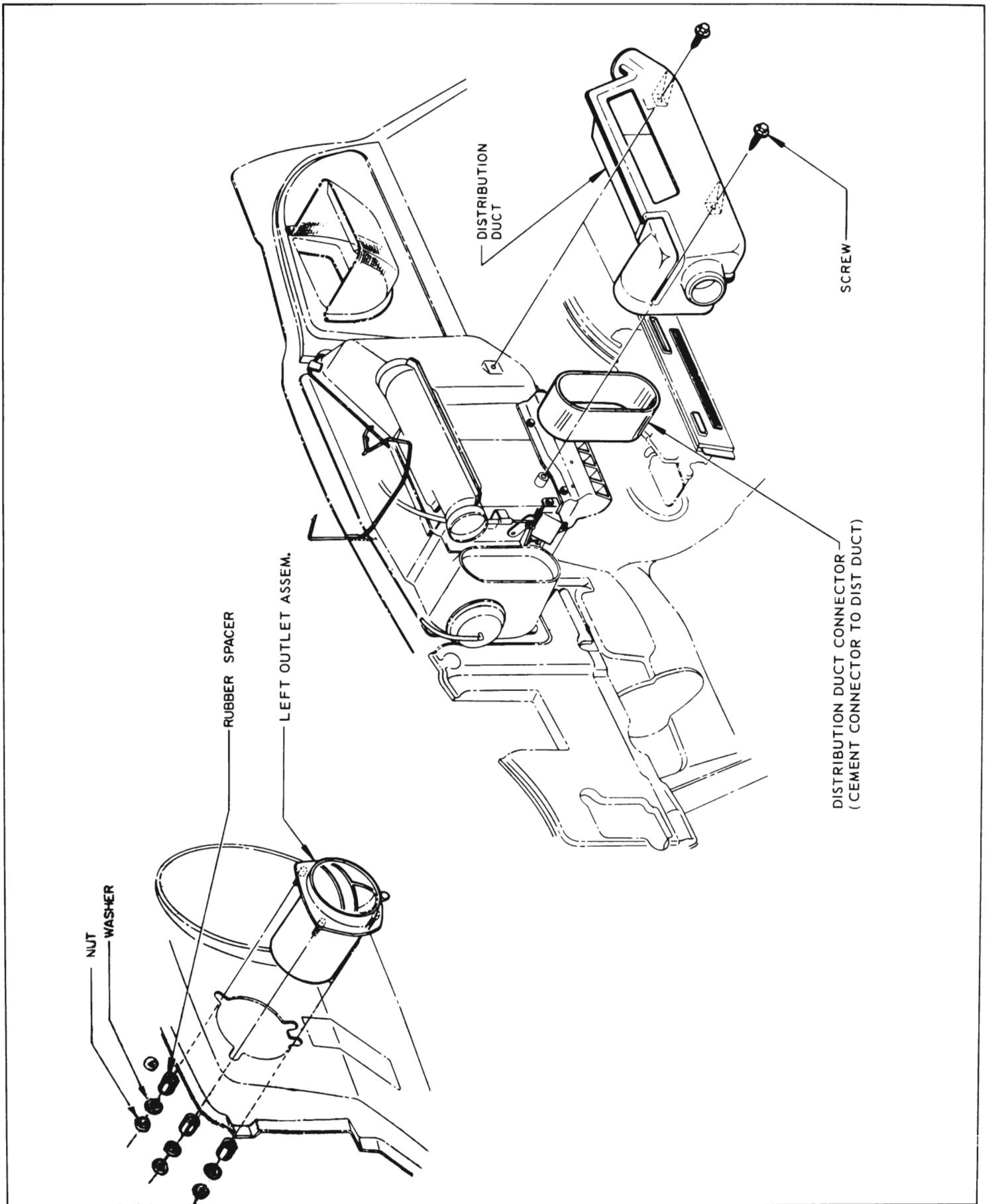

Figure 11-88—Distribution Duct Installation - 45000, 46000 and 48000 Series

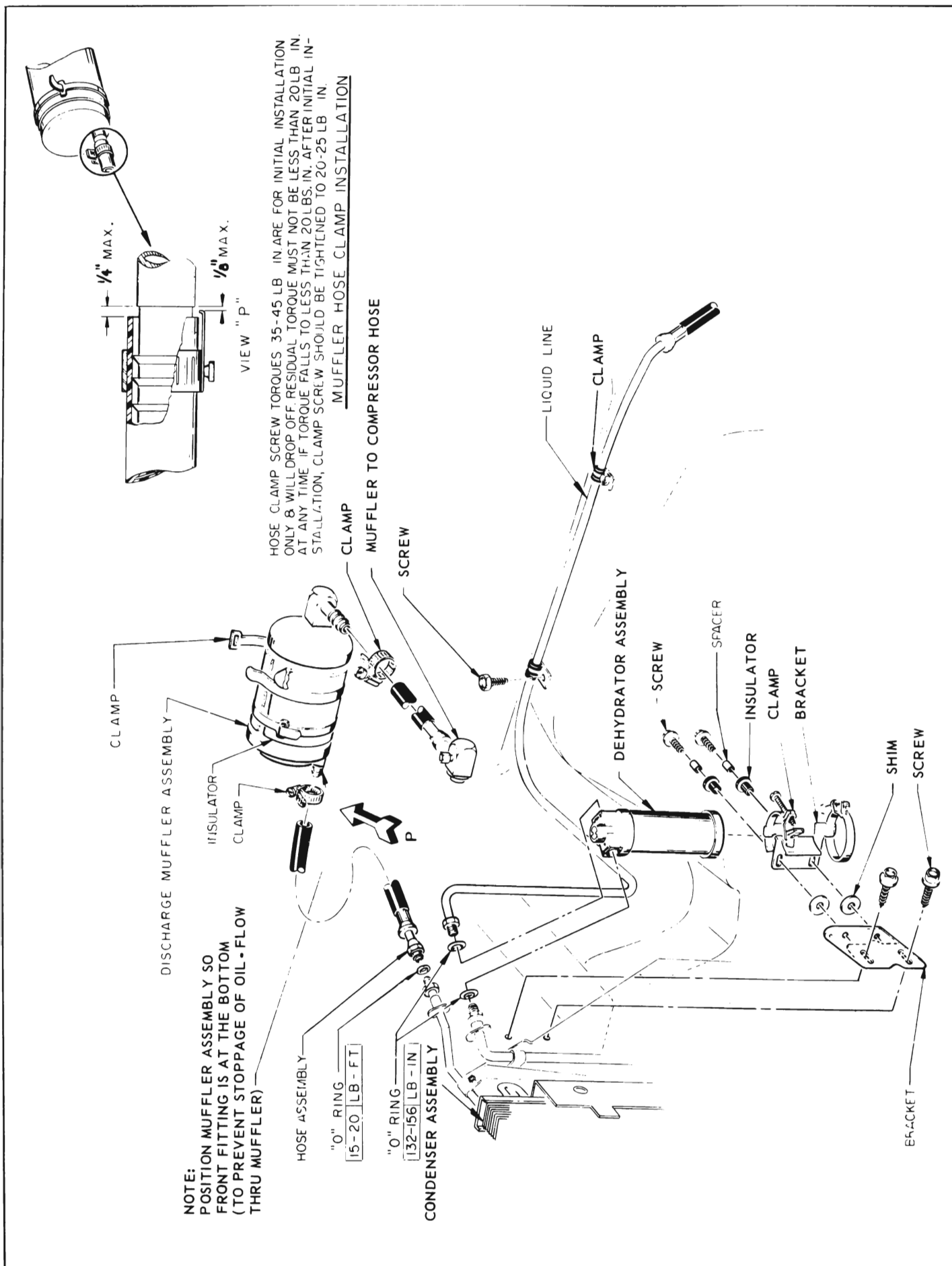

Figure 11-89—Muffler and Receiver - Dehydrator Installation - 49000 Series

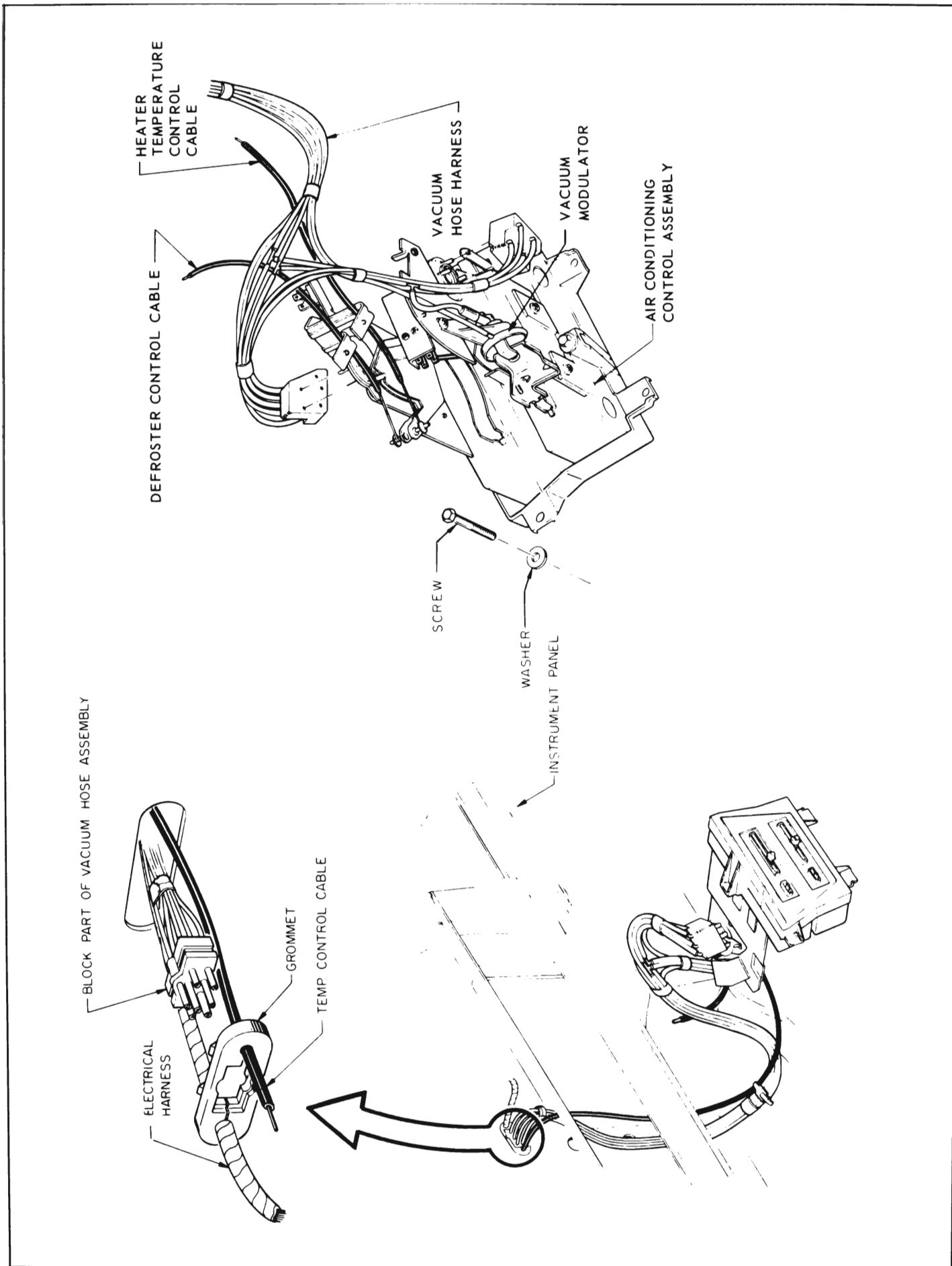

Figure 11-90—Vacuum Hose Installation at Rear of Control Assembly - 49000 Series

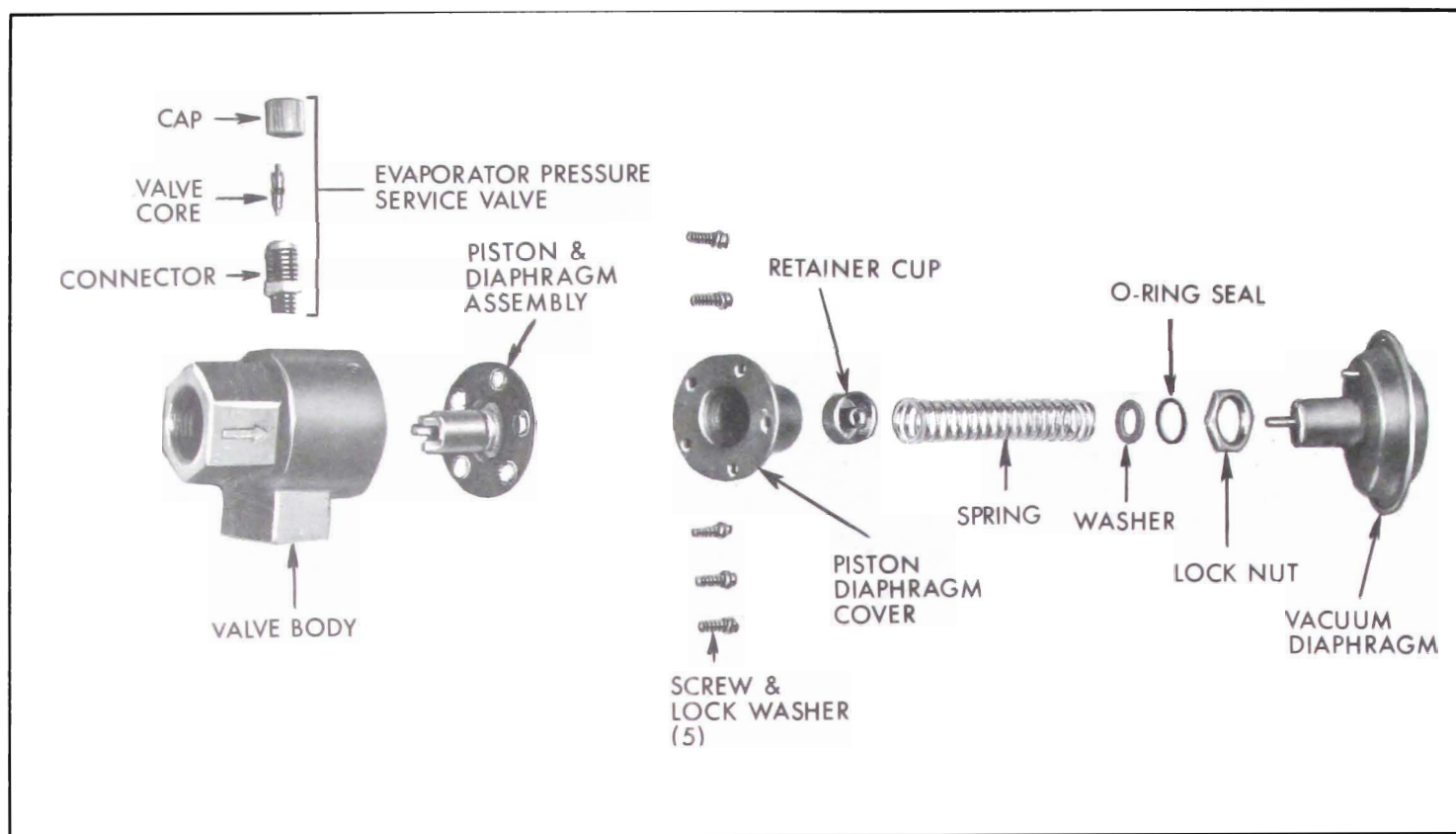

Figure 11-91—Suction Throttling Valve (Exploded View) - 49000 Series

through line connections to prevent piston from sticking on initial operation.

(c) Evacuate and charge the system. Leak test valve and connections. Correct any leaks.

(d) After system has been charged, on 49000 move air conditioning temperature control lever from one extreme to the other about 12 times with system operating to normalize the valve diaphragm.

(e) Check operation of the suction throttle valve, refer to subparagraph "f".

h. Disassembly and Assembly of Suction Throttle Valve

If test indicated suction throttle valve is defective, the valve should be overhauled as follows:

1. With valve removed from car, loosen lock nut on vacuum diaphragm and turn diaphragm as-

sembly out of cover. On 49000 valve, discard "O" ring on sleeve of diaphragm. See Figure 11-91.

NOTE: Figure 11-91 shows the 49000 Series suction throttle valve. The 45000, 46000 and 48000 suction throttle valve is basically the same except a different diaphragm is used and an "O" ring is not used on the vacuum diaphragm.

2. Remove spring from cover.
3. Remove the five screws that retain cover to body of valve and remove cover.
4. Remove diaphragm and piston assembly.
5. Remove retainer cup from diaphragm.

The diaphragm should be handled with care to avoid damage by scuffing, cutting or abrading the rubber and fabric surfaces. The piston diaphragm or the screen and retainer in the lower portion

of the piston should not be removed. The screen should, however, be examined for any foreign material or contamination. If necessary clean screen with a volatile solvent. All solvent should be removed from parts after cleaning.

In the event the exterior surface of the piston is damaged such as scored, scratched or nicked, in such a way as to cause it to bind in the bore, it should be replaced.

NOTE: It is recommended that no attempt be made to scamp, stone or crocus cloth these damaged areas due to the close tolerance that is required in the fitting of the parts for proper operation. In the event the diaphragm is found to be damaged, the piston assembly should be replaced.

Examine the body bore surfaces for any surface imperfections, foreign material and any obvious

damage that would cause the piston to not operate freely. The body should be replaced if the bore is damaged or if any cross threading or damage has been sustained around the connector parts.

6. Apply a light coat of 525 viscosity oil to the wall of the piston and insert it into the body of the valve.

7. Assemble the retainer cup to the diaphragm and place the cover in proper location over the diaphragm being sure the diaphragm holes are in line with the locating protrusions under the cover flange. Start the five screws into the body, but DO NOT TIGHTEN.

8. With the cover and body held loosely in one hand, insert a clean smooth rod, approximately 3/8" in diameter, through the inlet opening so as to contact the screen retainer in the bottom of the piston.

Carefully push the piston into the cover so that the diaphragm positions properly into the cavity of the cover and does not become pinched under the flange.

Remove the rod from the inlet opening and insert it through the upper portion of the cover. It should contact the center post of the cup. Press lightly downward so as to cause the piston to seat against the inner shoulder of the body. While the cup, diaphragm and piston are held down, tighten the five screws to 45 to 50 inch pounds torque.

9. Place locknut on vacuum diaphragm and install a new "O" ring on diaphragm.

NOTE: The 45000, 46000 and 48000 Series valve diaphragm does not use an "O" ring.

10. Insert washer and spring in vacuum diaphragm.

11. Reassemble vacuum diaphragm cover and screw in approximately ten turns.

12. Install suction throttle valve as described in subparagraph "g" and adjust as described in subparagraph "f".

i. Removal and Installation of Compressor

1. Discharge refrigerant from system as described in subparagraph "c".

2. Remove center bolt to remove Schrader valve retaining plate from rear end of compressor.

3. Cover the openings in lines and compressor with tape to exclude dirt.

4. Disconnect magnetic clutch coil wire connector, then loosen the belts and remove compressor from its mounting on engine. See Figures 11-92 and 11-93.

Do not place compressor in sun or near heat because it still contains some refrigerant.

IMPORTANT: Whenever a compressor replacement is being made the oil in the original compressor should be drained and measured. The new compressor should contain the same amount of new 525 viscosity oil as was drained from the original compressor. This step is necessary as some of the oil from the original compressor remains in the system. The addition of a complete change of oil, in addition to the oil remaining in the system, would impair the cooling ability of the unit.

CAUTION: If it is evident that the air conditioner has lost a large amount of oil, refer to subparagraph "j" for procedure for adding oil to compressor.

5. Install compressor by reversing procedure for removal, paying attention to the following points:

(a) Inspect drive belts and pulley grooves for conditions that might cause slippage. If a belt is cracked, frayed, or oil soaked,

or is worn so that it bottoms in pulley grooves, replace both belts. Belts are furnished in matched sets to insure even tension.

(b) Use new "O" rings when attaching valve assemblies to compressor.

(c) Adjust compressor belt tension (Refer to Group 2).

(d) Evacuate, leak test and charge air conditioner system (par. 11-18).

j. Checking Compressor Oil and Adding Oil

The six cylinder air conditioner compressor is initially charged with 10-1/2 fluid ounces of 525 viscosity Frigidaire Refrigerant oil. After the air conditioner system has been operated, oil circulates throughout the system with the refrigerant. Hence, while the system is running, oil is leaving the compressor with the high pressure gas and is returning to the compressor with the suction gas.

When the air conditioner is operated around 1000 to 1500 engine rpm's, in the maximum cooling position and blower on high, approximately 4 ounces of oil remains in the compressor while the rest is distributed in the various air conditioner components. At high engine rpm's, a lesser amount of oil will be retained in the compressor (as little as 2 ounces of oil which is adequate for lubrication of compressor).

The oil balance in the system has been carefully established. It is important in any servicing operations to neither add or subtract oil which would cause the total oil change in the system to vary from 10-1/2 fluid ounces. If the total oil change is less, lubrication of the compressor may not be adequate; if too much oil is in the system, this will reduce the

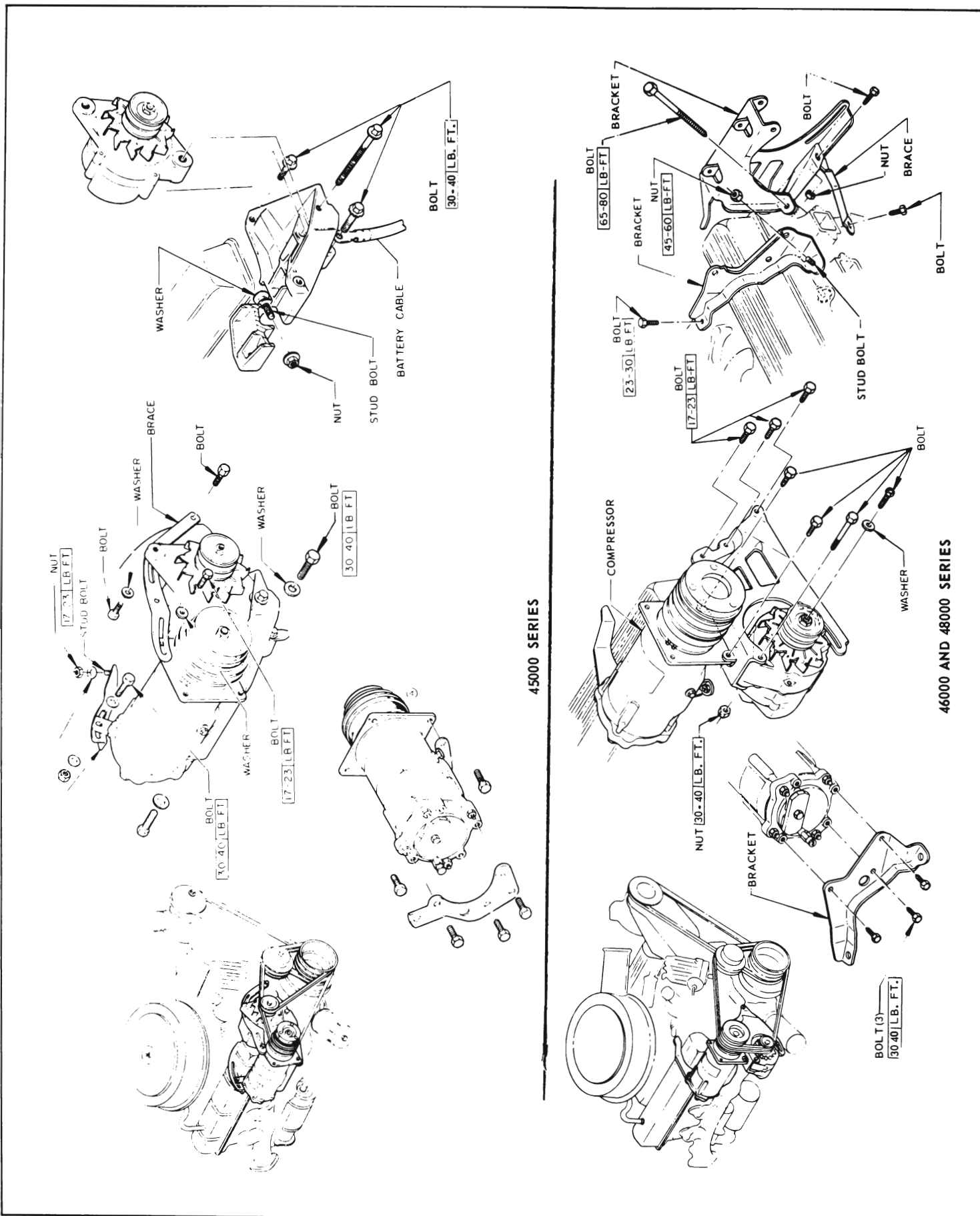

Figure 11-92—Compressor Installation - 45000, 46000 and 48000 Series

oil is involved, add oil to the new unit per item 1 on chart. The oil can be poured directly into the part being replaced.

k. Flushing Air Conditioner System

Flushing the air conditioner

system can be accomplished by connecting a refrigerant drum to the unit to be flushed, and then turning the drum upside down

CONDITION	AMOUNT OF OIL DRAINED FROM COMPRESSOR	AMOUNT OF 525 OIL TO INSTALL IN COMPRESSOR
1. Major loss of oil and a component has to be replaced.	a. More than 4 oz. b. Less than 4 oz.	a. Amount drained from compressor plus amount for component being replaced as follows: Evaporator - Add 3 oz. Condenser - Add 1 oz. Receiver Dehydrator - Add 1 oz. b. Install 6 oz. plus amount for component being replaced as shown above.
2. Compressor being replaced with a service compressor and there wasn't a major loss of oil from the air conditioner system.	a. More than 1-1/2 oz. (See Note) b. Less than 1-1/2 oz.	a. Same amount as drained from compressor being replaced. b. Install 6 oz.
3. Same as Step 2 except there has been a major loss of oil.	a. More than 4 oz. b. Less than 4 oz.	a. Same amount as drained from compressor being replaced. b. Install 6 oz.
4. Compressor has been in-operative and rebuilt and there wasn't a major loss of oil from air conditioner system.	a. More than 1-1/2 oz. (See Note) b. Less than 1-1/2 oz.	a. Same amount as drained from compressor plus 1 oz. additional. b. Install 7 oz.
5. Same as Step 4 except there has been a major loss of oil.	a. More than 4 oz. b. Less than 4 oz.	a. Same amount as drained from compressor plus 1 oz. additional. b. Install 7 oz.
<p>NOTE: If more than 1-1/2 oz. of clean oil was drained from compressor and there is little or no signs of oil being lost from system, install this amount of oil in replacement compressor (plus 1 oz. additional in repaired compressor).</p>		

and opening the drum shut-off valve to pour refrigerant through the unit. The unit should be supported so that the refrigerant passing through it will be directed into an area where a temperature of -21.7°F . will do no damage. When a unit is not removed such as a condenser, disconnect the inlet and outlet lines before flushing it out.

CAUTION: When liquid refrigerant is poured from the drum into an area where atmospheric pressure exists, its temperature will immediately drop to -21.7°F .

In order to keep the expansion valve open when flushing the evaporator with refrigerant, the expansion valve bulb must be detached from the evaporator outlet tube.

In all cases where it is necessary to flush the air conditioner system, the receiver-dehydrator should be replaced. Also, the expansion valve inlet screen should be cleaned.

Dry nitrogen which is much less expensive than refrigerant, is preferred, if available, for flushing out the air conditioner system. Nitrogen will not cause the temperature to drop as refrigerant-12 does. The cold temperatures make it difficult to remove the contaminated oil from the unit being flushed. Also, the dry nitrogen will remove moisture from the system.

I. Removal of Evaporator Assembly and Air Distribution Parts

Figures 11-94 and 11-95 show the installation of the evaporator assembly and air distribution system on the 45000, 46000 and 48000 Series.

Figures 11-96 and 11-97 show the installation of the 49000 Series evaporator and air distribution system.

To remove the evaporator assembly on the 49000, remove the brackets that retain assembly to instrument panel. Then disconnect assembly from distribution duct and right outer outlet, and lower assembly down from under instrument panel. Complete removal by disconnecting lines from evaporator assembly.

When reinstalling assembly be sure to properly install drain hoses and use new "O" rings on refrigerant lines. See Figure 11-97.

To remove distribution duct to service heater core on 49000, lower evaporator assembly from instrument panel. Then disconnect distribution duct, and remove from right side of instrument panel.

11-16 COMPRESSOR CLUTCH, COIL AND SHAFT SEAL REMOVAL AND INSTALLATION

It is not necessary to remove compressor from refrigeration system to service clutch parts. It may be necessary to loosen it on its mounting to remove clutch pulley.

CAUTION: Never stand compressor on pulley end.

a. Clutch Drive Plate Removal

1. Hold the clutch drive plate hub with J-9403 wrench and use J-9399 special thin wall $9/16''$ socket to remove shaft nut. See Figure 11-98.

2. Screw threaded Hub Puller J-9401 into the drive plate hub.

Hold body of tool with a wrench and tighten the center screw to remove clutch drive plate. See Figure 11-99.

3. Remove clutch hub key from compressor shaft or from clutch drive plate hub.

4. Remove clutch drive plate assembly retainer ring, using J-5403 No. 21 Truarc Pliers. See Figure 11-100. Remove spacer from inside hub of clutch drive plate.

b. Clutch Drive Plate Installation

1. Insert clutch hub key into hub of clutch drive plate so it projects approximately $3/16''$ out of end of keyway. See Figure 11-101.

2. Line up key in hub with keyway and position clutch drive plate on shaft.

3. Place Spacer J-9480-2 on Clutch Drive Plate Installer J-9480-1 and thread installer on end of compressor shaft. See Figure 11-102. Press the clutch drive plate on shaft until there is approximately $3/32''$ space between the friction faces of the drive plate and pulley as shown in Figure 11-102.

4. Remove installer and insert spacer inside clutch drive plate hub.

5. Install clutch drive plate retainer ring with flat side of ring facing spacer, using J-5403, No. 21 Truarc Pliers.

6. Install a new shaft nut, using J-9399, special thin wall $9/16''$ socket. Tighten to 15 lb. ft. torque. The air gap between the friction faces of the pulley and clutch drive plate should now be between $1/32''$ and $1/16''$ clearance. See Figure 11-103.

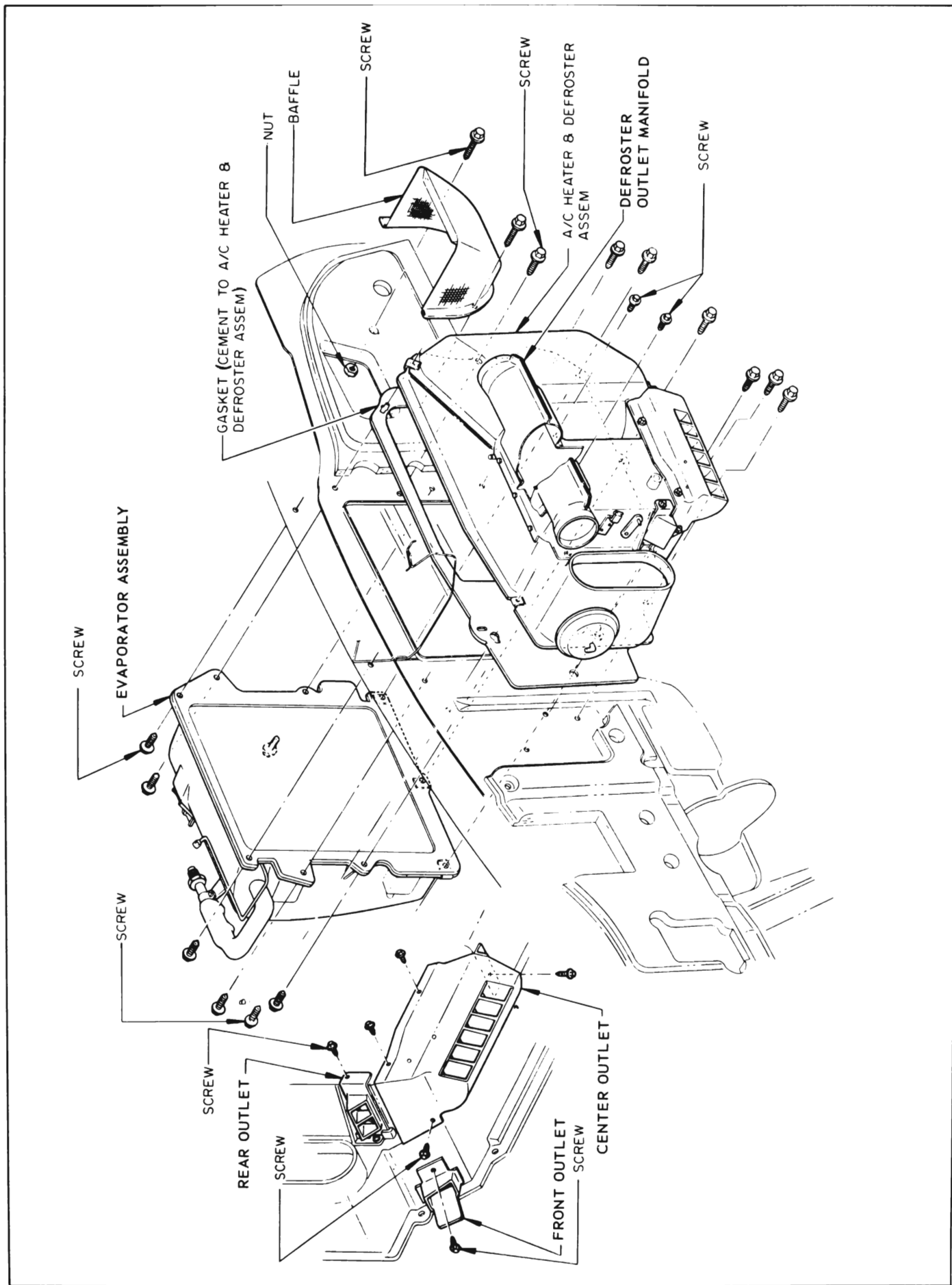

Figure 11-95—Air Conditioner - Heater and Defroster Assembly, Manifold and Attaching Outlets - 45000, 46000 and 48000 Series

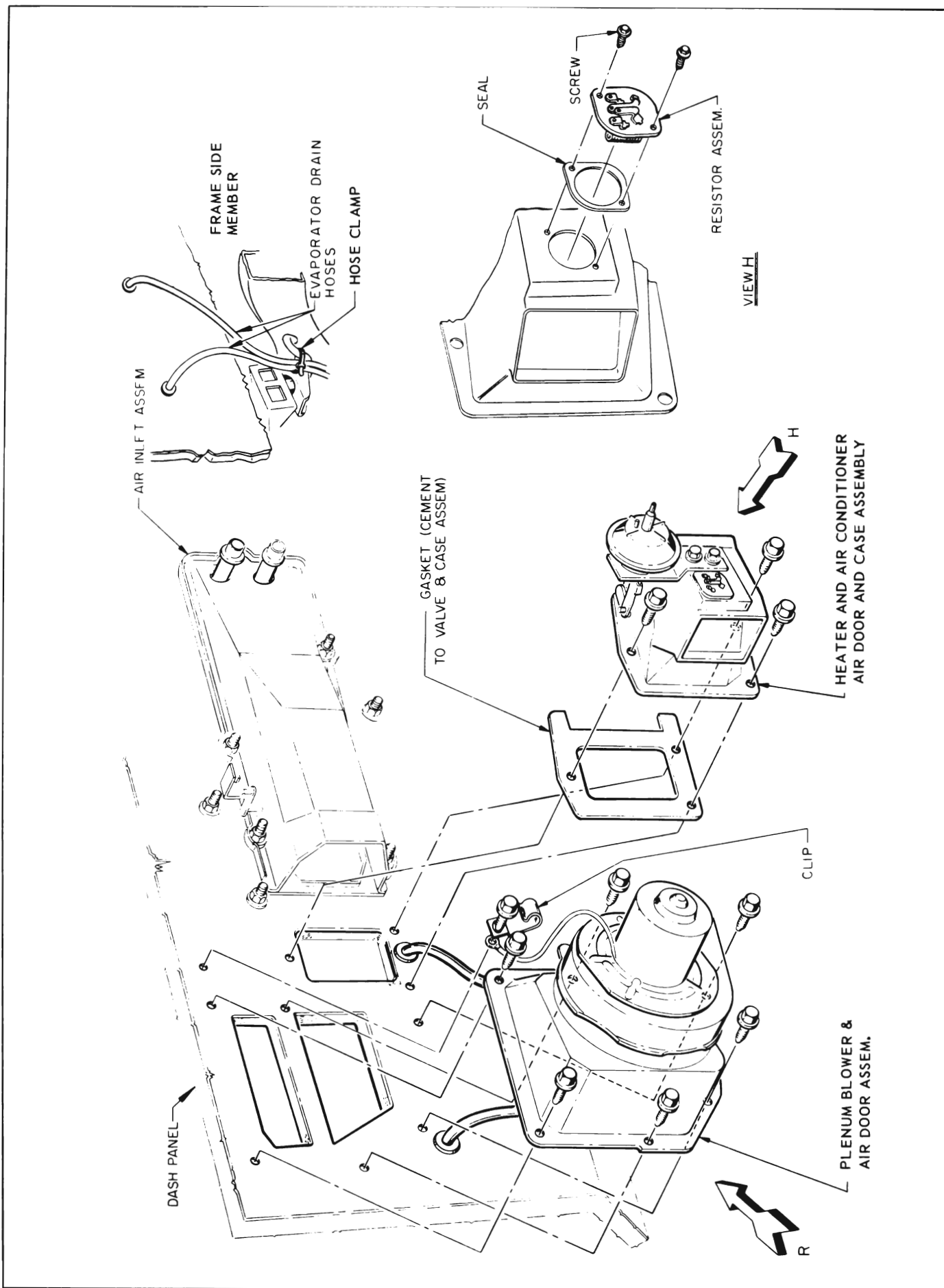

Figure 11-96—Plenum Blower and Air Door Assembly, and Heater-Air Conditioner Air Door and Case Installation - 49000 Series

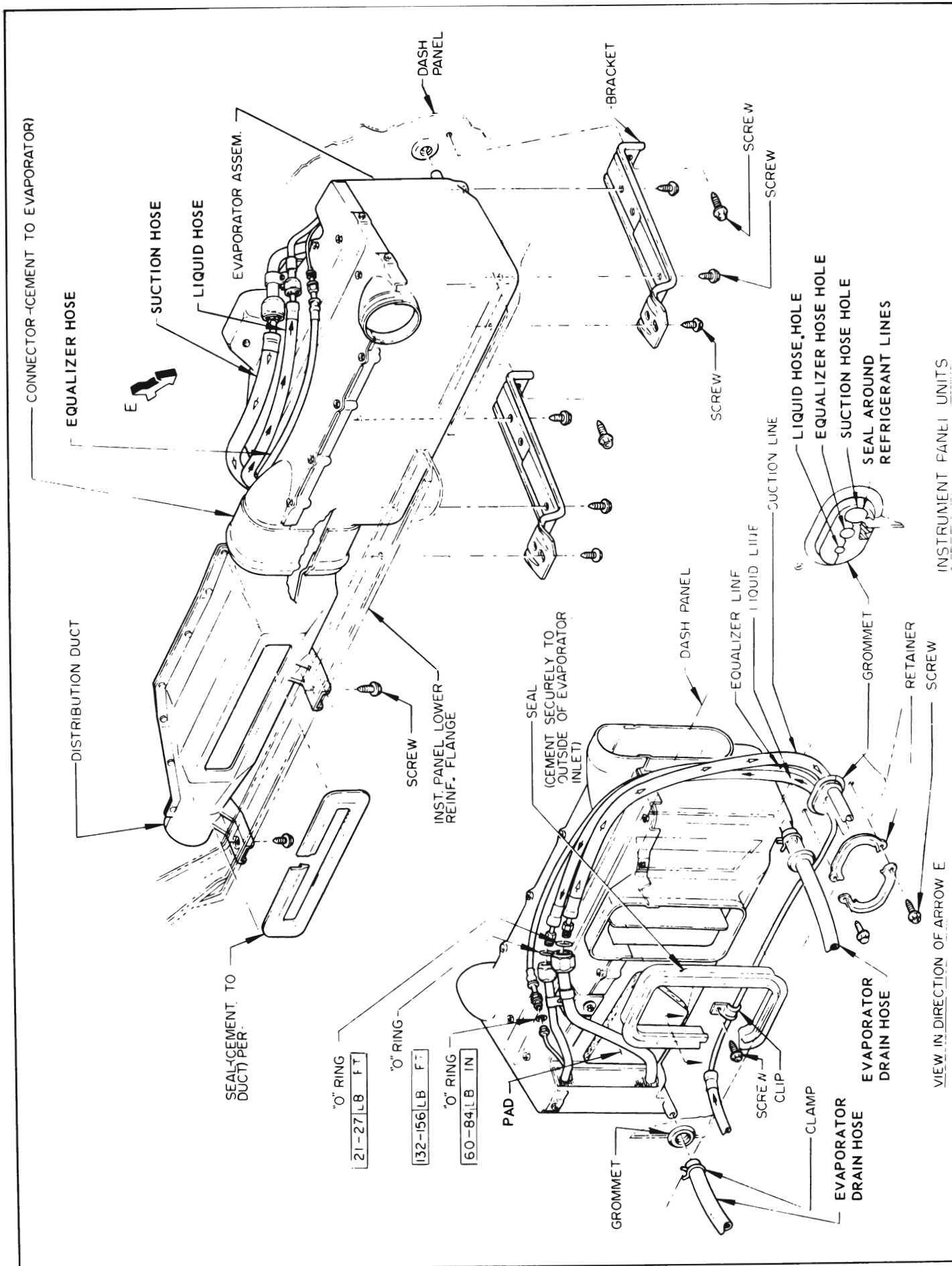

Figure 11-97—Evaporator and Distributor Duct Installation - 49000 Series

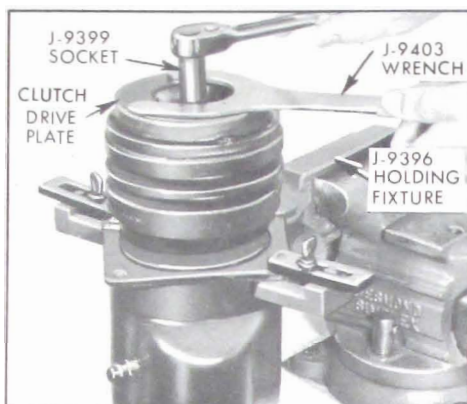

Figure 11-98—Removing Shaft Nut

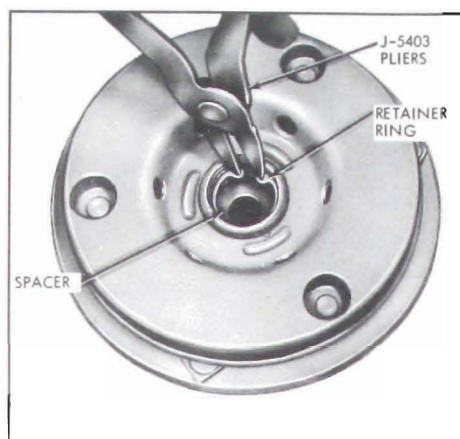

Figure 11-100—Removing Clutch Drive Plate Retainer Ring

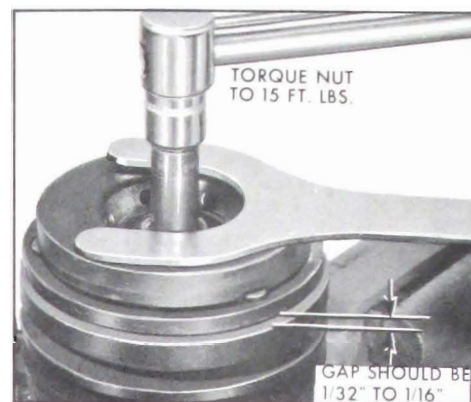

Figure 11-103—Torquing Shaft Nut

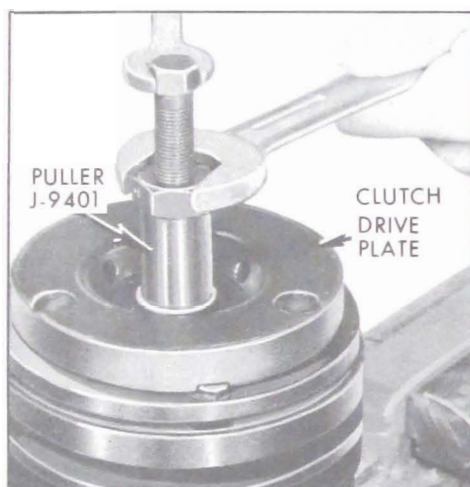

Figure 11-99—Removing Clutch Drive Plate

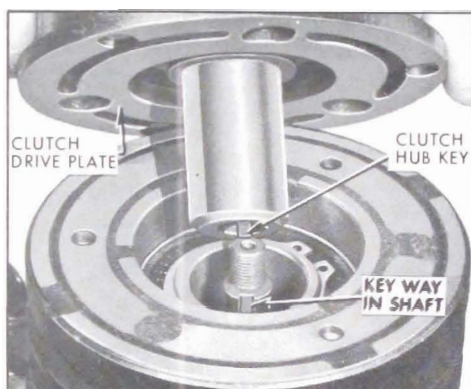

Figure 11-101—Positioning Clutch Drive Plate on Shaft

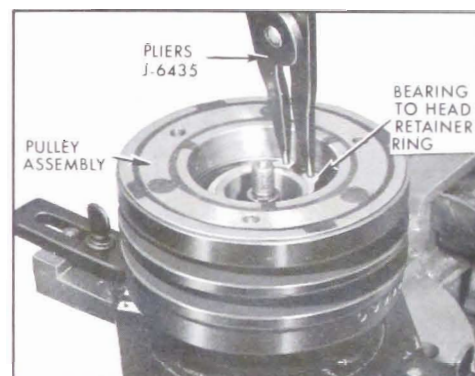

Figure 11-104—Removing or Installing Bearing to Head Retainer Ring

c. Pulley Assembly and Bearing Removal

1. Remove clutch drive plate. Subparagraph "a".

2. Remove pulley assembly retainer ring, using J-6435, No. 26 Truarc Pliers. See Figure 11-104.

3. Place J-9395 Puller Pilot over compressor shaft and remove pulley assembly, using J-8433 Puller. See Figure 11-105.

IMPORTANT: Puller Pilot J-9395 must be used, or force will cause shaft to move in swash plate, resulting in damage to the cylinder mechanism.

NOTE: Do not remove pulley bearing unless it is going to be replaced.

4. Remove bearing to pulley retainer wire with a small screwdriver. See Figure 11-106.

5. Remove bearing, using punch or a suitable socket.

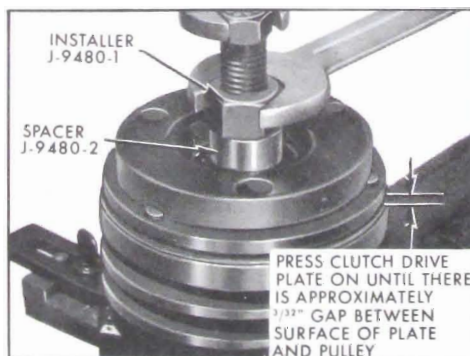

Figure 11-102—Installing Clutch Drive Plate

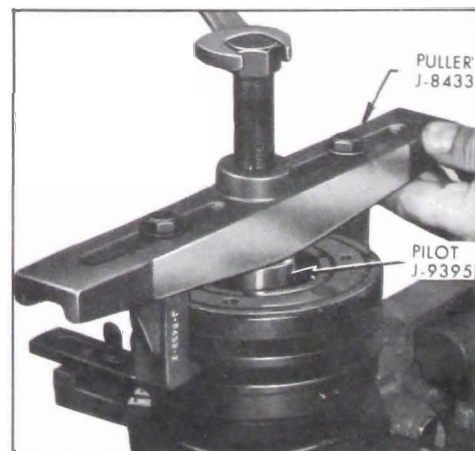

Figure 11-105—Removing Pulley Assembly

d. Pulley Assembly and Bearing Installation

If the existing pulley assembly and clutch drive plate are to be reused, clean the friction faces on each part with trichloroethylene, alcohol or similar solvent. If

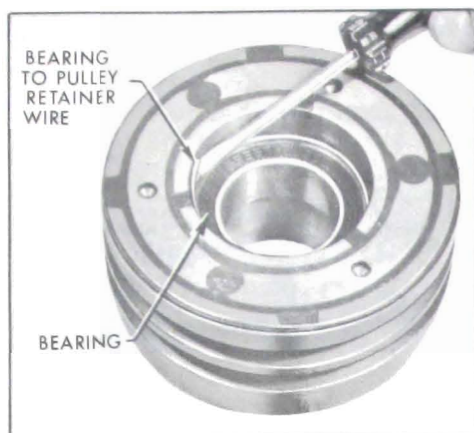

Figure 11-106—Removing Bearing to Pulley Retainer Wire

these parts show evidence of warpage, due to overheating, they should be replaced.

1. When replacing a new pulley bearing into the pulley assembly use J-9481 Pulley Bearing Installer and Drive Handle J-8092 as shown. See Figure 11-107.
2. Replace the bearing to pulley retainer wire in pulley, being sure it is properly seated in groove.
3. Support bottom of compressor and install the pulley assembly on the neck of the compressor, using J-9481 installed on J-8092

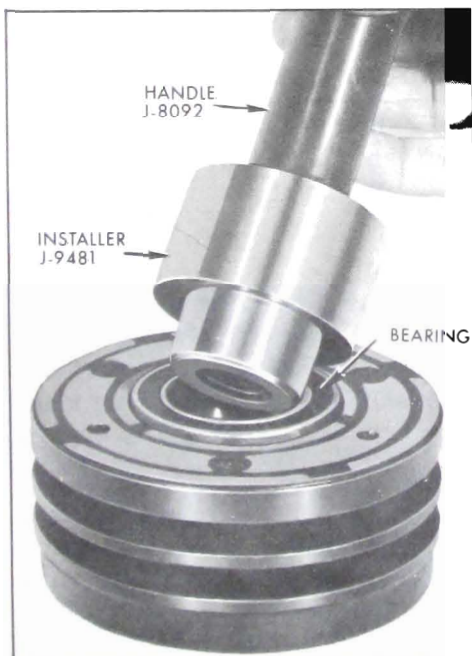

Figure 11-107—Installing Pulley Bearing

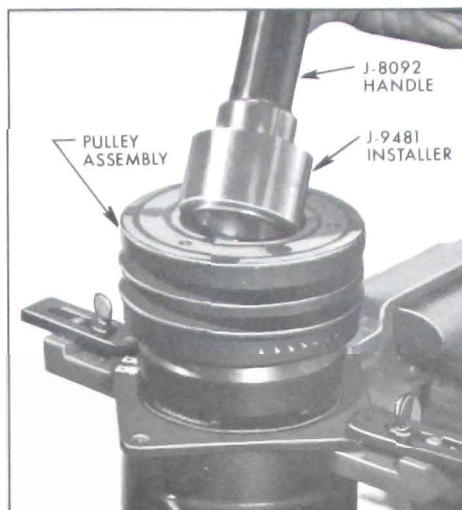

Figure 11-108—Installing Pulley Assembly

as shown. See Figure 11-108. Pulley should rotate freely.

4. Install bearing to head retainer ring with flat side of retainer toward bearing, using J-6435, No. 26 Truarc Pliers.
5. Install clutch drive plate assembly. Subparagraph "b".

e. Coil and Housing Assembly Removal

1. Remove clutch drive plate. Subparagraph "a".
2. Remove pulley assembly and bearing. Subparagraph "c".
3. Note position of electrical terminals and scribe location of coil and housing assembly terminals on compressor body to insure correct location of terminals when coil is reinstalled.

4. Use J-6435, No. 26 Truarc Pliers and remove coil and housing retainer ring, then remove coil and housing assembly. See Figure 11-109.

f. Coil and Housing Assembly Installation

1. Position coil and housing assembly on compressor front head so electrical terminals are in

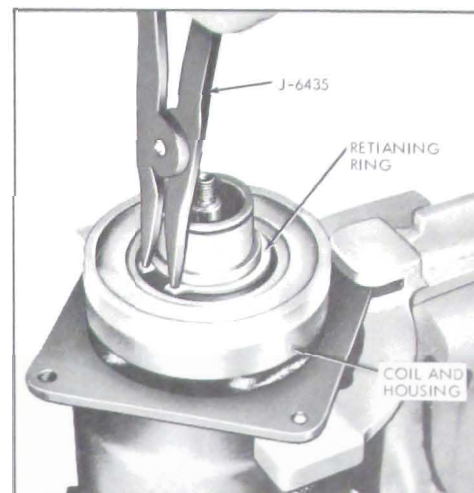

Figure 11-109—Removing or Installing Coil and Housing Retainer Ring

their original location as previously scribed on compressor body. Make certain coil and housing are properly seated in dowels.

2. Replace the coil and housing retainer ring with flat side of ring facing coil, using J-6435, No. 26 Truarc Pliers.
3. Install pulley assembly and bearing. Subparagraph "d".
4. Install clutch drive plate. Subparagraph "b".

g. Shaft Seal Removal

1. Remove clutch drive plate. Subparagraph "a".
2. Remove seal seat retaining ring from inside front head, using

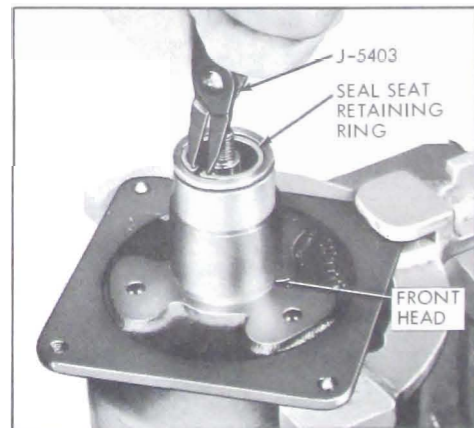

Figure 11-110—Removing or Installing Seal Seat Retainer Ring

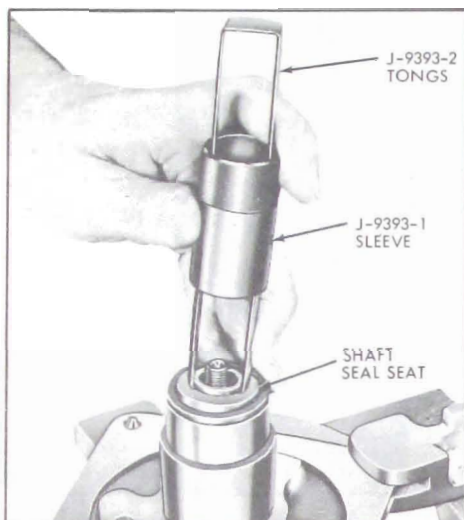

Figure 11-111—Removing or Installing Shaft Seal Seat

J-5403, No. 21 Truarc Pliers. See Figure 11-110.

3. Remove shaft seal seat, using J-9393-1 and 2 to grasp flange on seal seat. See Figure 11-111. Pull straight out on end of tool to remove.

4. Engage tabs on shaft seal assembly with locking tangs on J-9392 Seal Installer and Remover. Press down on tool and twist clockwise to engage. Remove shaft seal by pulling straight out. See Figure 11-112.

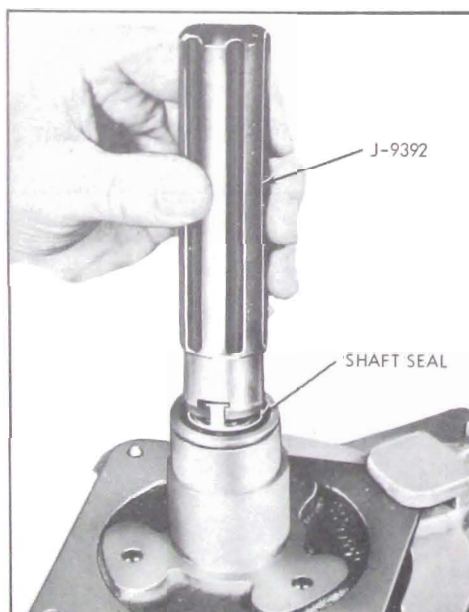

Figure 11-112—Removing or Installing Shaft Seal

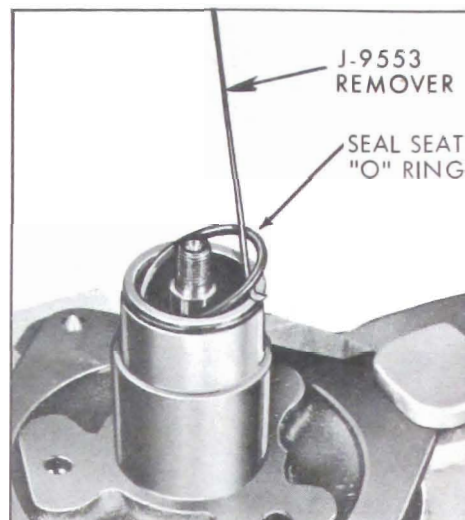

Figure 11-113—Removing Seal Seat O-Ring

5. Remove seal seat "O" ring from interior of hub of front head using J-9553 Remover. See Figure 11-113.

h. Shaft Seal Installation

NOTE: Apply 525 compressor oil to seal parts during assembly.

1. Place shaft seal on J-9392 Installer and insert shaft seal inside front head. Be sure seal is

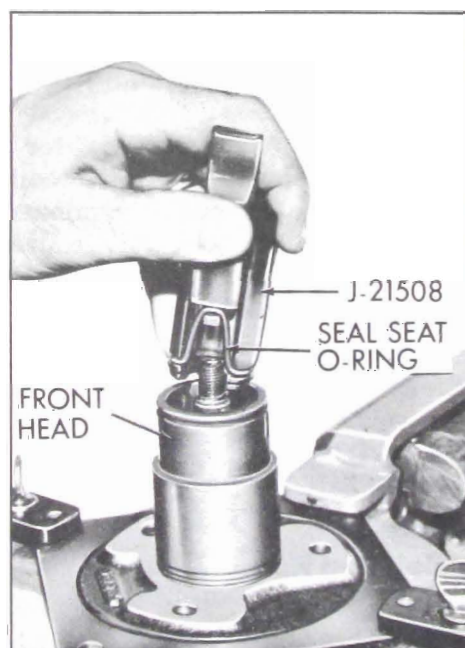

Figure 11-114—Installing Seal Seat O-Ring

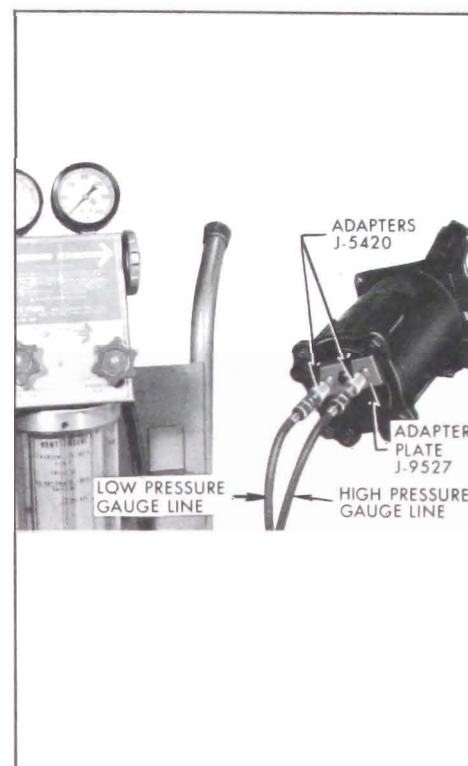

Figure 11-115—Charging Compressor to Check for Leaks

properly seated on shaft. The shaft has two flats provided for the shaft seal.

2. Install a new seal seat "O" ring in its groove inside front head using Installer J-21508. Be sure it is not in seal seat retaining ring groove. See Figures 11-70 and 11-114.

3. Position shaft seal seat on shaft and use Sleeve J-9393-1 to push seal seat down inside front head.

4. Install seal seat retainer ring with flat side of ring going inward using J-5403, No. 21 Truarc Pliers. If necessary, position Sleeve J-9393-1 on retaining ring, and push down on it to engage ring in its groove.

5. Attach charging line Adapter Plate J-9527 on rear of compressor and pressurize suction side of compressor with Refrigerant-12 at pressure corresponding to room temperature. Rotate compressor shaft several times. See Figure 11-115. Leak test with

leak detector and correct any leaks.

6. Install clutch drive plate. Subparagraph "b".

11-17 DISASSEMBLY, INSPECTION AND ASSEMBLY OF COMPRESSOR INTERNAL PARTS

IMPORTANT: A clean work bench, orderliness of the work and a place for all parts being removed and replaced are of great importance. Any attempt to use makeshift or inadequate tools may result in damage and/or improper operation of the compressor.

a. Rear Head and Oil Pump Removal

CAUTION: Under NO circumstances should compressor be placed on the pulley end.

1. Seal compressor fitting openings and openings in compressor rear head.

2. Thoroughly clean exterior of compressor assembly and blow dry with compressed air.

3. Place compressor assembly on clean, dry work bench.

NOTE: If compressor is not going to be disassembled any further than rear head or oil pump, omit Steps 4, 5, 6, 7 and 8.

4. Remove compressor oil drain plug, tilt compressor and drain oil into clean dry container. It may be possible to get only 4 to 6 ozs. of oil from the compressor.

5. Remove clutch drive plate. Paragraph 11-16, subparagraph "a".

6. Remove pulley assembly. Paragraph 11-16, subparagraph "a".

7. Remove coil and housing assembly. Paragraph 11-16, subparagraph "e".

8. Remove shaft seal. Paragraph 11-16, subparagraph "g".

9. Attach J-9396 Holding Fixture to compressor and firmly mount assembly in vise. See Figure 11-116.

10. Remove pressure relief valve and washer if head is going to be replaced.

11. Remove four lock nuts from threaded studs welded to compressor shell, and remove rear

head by tapping lightly with mallet.

12. Examine teflon surface on the rear head casting webs. If any damage is observed, the head should be replaced. See Figure 11-117.

13. Remove suction screen and examine for damage or contamination. Clean or replace as necessary.

14. Mark rear side of both oil pump inner and outer rotors with a pencil so that they can be re-installed in same position. Remove rotors and inspect for damage. Replace both rotors if one or both show damage.

15. Remove and discard rear shell to head "o" ring.

16. Carefully remove rear discharge valve plate by prying up on assembly as shown with screwdrivers and examine discharge valve reeds and seats. See Figure 11-118. Replace entire assembly if excessively scored or if any one of the three reeds are broken, or seats are damaged.

17. If rear suction valve reed disc did not come out with valve plate, carefully remove reed as shown with two small screwdrivers. See Figure 11-119. Replace valve disc if damaged.

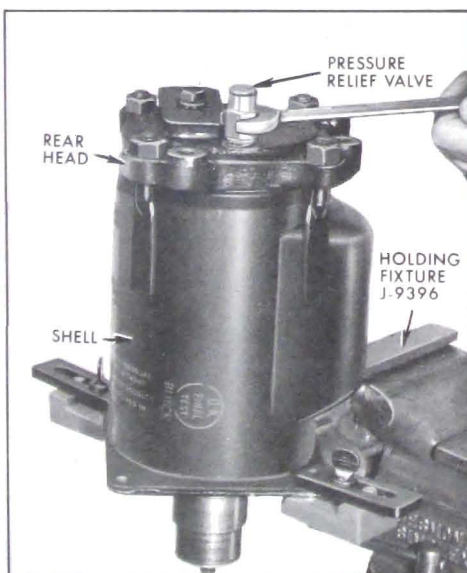

Figure 11-116—Removing or Installing Pressure Relief Valve

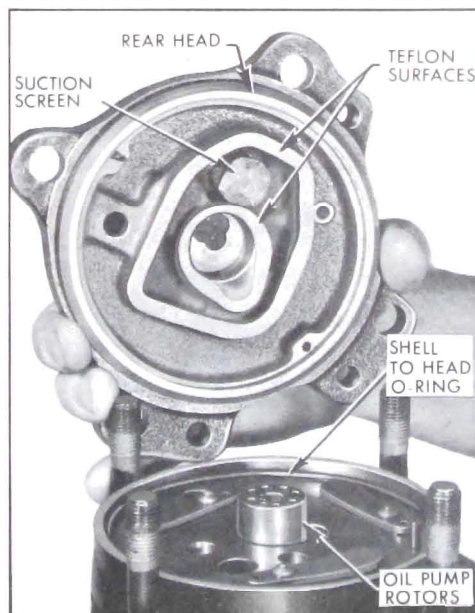

Figure 11-117—Rear Head

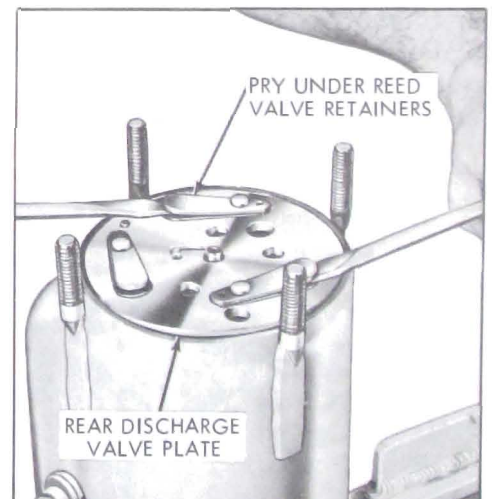

Figure 11-118—Removing Rear Discharge Valve Plate

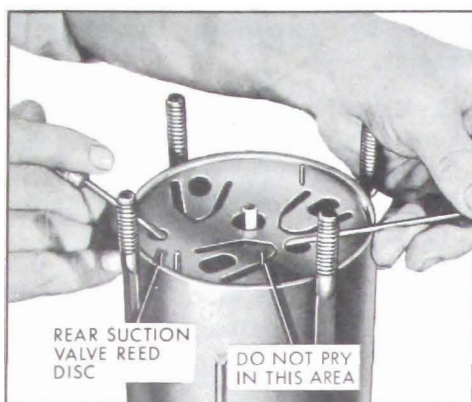

Figure 11-119—Removing Rear Suction Valve Reed Disc

NOTE: See subparagraph “g” for installation of rear head and oil pump.

b. Compressor Cylinder Assembly and Front Head Removal

1. Remove oil inlet tube, using J-6586 Remover. See Figure 11-120. If tube “O” ring did not come out with tube, remove it from cylinder with small wire.

2. Push on front of compressor shaft to remove cylinder assembly from shell. See Figure 11-121. The cylinder assembly will slide out of shell when shell is inverted.

CAUTION: Do not hammer or use force on end of shaft.

3. If the front discharge valve plate and suction valve reed disc were removed with cylinder assembly, remove these parts from

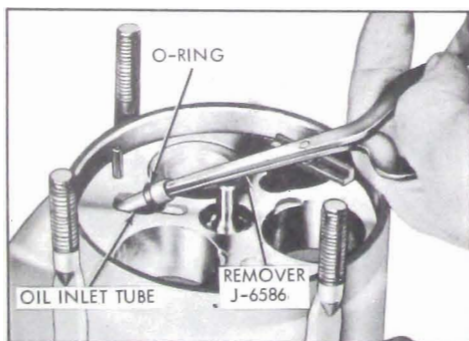

Figure 11-120—Removing Oil Inlet Tube

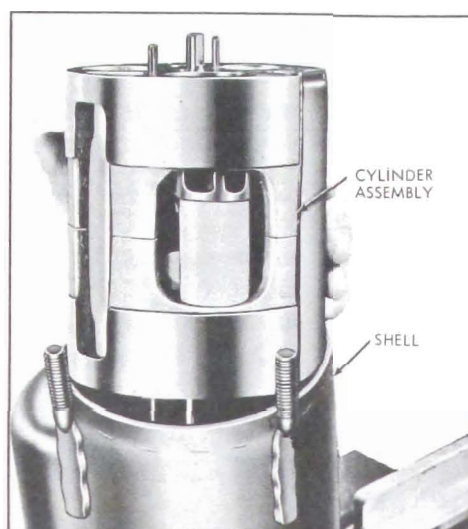

Figure 11-121—Removing Cylinder Assembly

shaft before proceeding and examine for damage.

4. Examine cylinder assembly for any obvious damage.

NOTE: If cylinder assembly has sustained major damage, due possibly to loss of refrigerant and/or oil, it may be necessary to replace unit with a service cylinder and shaft assembly rather than replace individual parts.

5. Remove compressor front head, using rubber mallet or wood block to unseat head from shell. See Figure 11-122. Care must be used to protect teflon surface on head from being damaged.

6. Remove and discard front head to shell “O” ring seal.

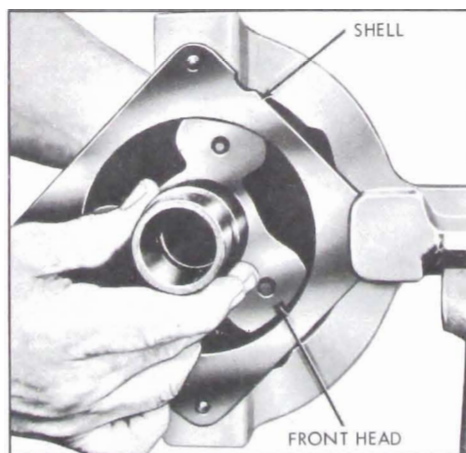

Figure 11-122—Removing Front Head

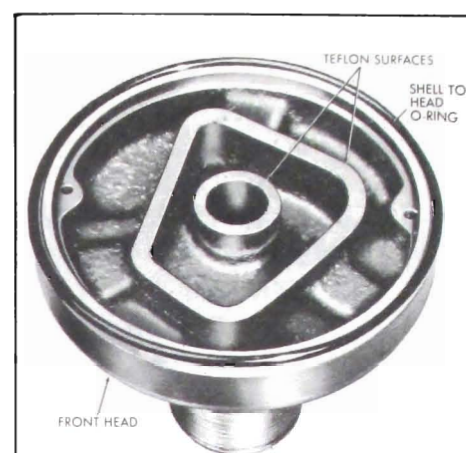

Figure 11-123—Front Head

7. Examine teflon sealing surface on front head for damage and/or deep scratches. Replace if necessary. See Figure 11-123.

NOTE: If compressor cylinder assembly is going to be replaced, omit subparagraphs “c”, “d” and “e”.

c. Disassembly of Compressor Cylinder Assembly

1. Remove suction pass cover as shown in Figure 11-124 and discard seal on cover.

2. Place cylinder assembly in fixture as shown.

3. Number pistons “1”, “2” and “3” and their cylinder bores so parts can be replaced in their original locations.

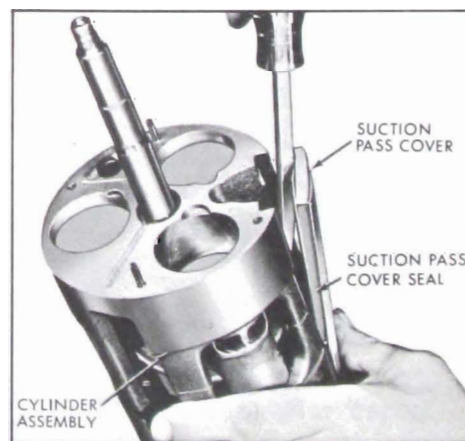

Figure 11-124—Removing Suction Pass Cover and Seal

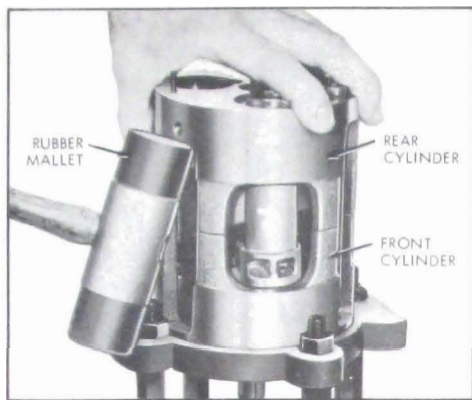

Figure 11-125—Separating Cylinder Halves

4. Obtain clean J-9402 assembly parts tray to retain compressor parts during disassembly.

5. Separate front and rear cylinder halves, using a wood block or rubber mallet. See Figure 11-125. Rotate swash plate so that discharge tube does not contact it. A 9/16" open end wrench may be used on the shaft seal area of shaft to rotate swash plate.

6. Remove rear cylinder half from pistons.

7. Rotate shaft until a piston is at its highest point. Push up on shaft and remove one piston assembly at a time. See Figure 11-126. Place parts in parts tray to keep them separated. See Figure 11-127.

8. Remove piston rings, balls and shoe discs. Discard the shoe discs. Examine piston balls, if satisfactory for reuse, place in parts tray with proper end of

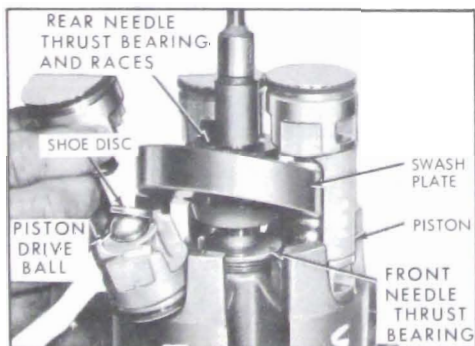

Figure 11-126—Removing Piston Assembly

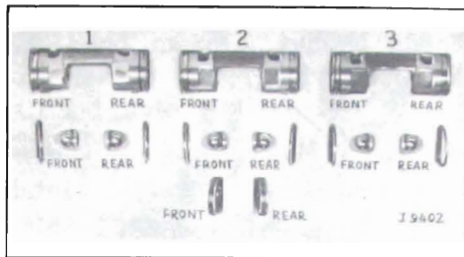

Figure 11-127—Parts Tray J-9402

piston. The front end of piston has identifying notch in casting web. See Figure 11-128.

9. Remove rear needle thrust bearing and races. Discard all three pieces.

10. Push on shaft to remove shaft and swash plate assembly front cylinder half.

11. Remove front needle thrust bearing and races. Discard all three pieces.

12. Remove discharge tube from cylinder half by twisting it out with suitable pliers or by holding on to it with pliers and tapping on pliers.

13. Examine swash plate surfaces for excessive scoring or damage. If satisfactory, reuse. If necessary, replace mainshaft and swash plate assembly.

14. Wash compressor internal parts in a tank of clean trichloroethylene, alcohol or similar solvent. Blow dry all parts, using a source of clean, dry air. If drive balls show any signs of damage, replace.

15. Examine the front and rear cylinder halves and replace if

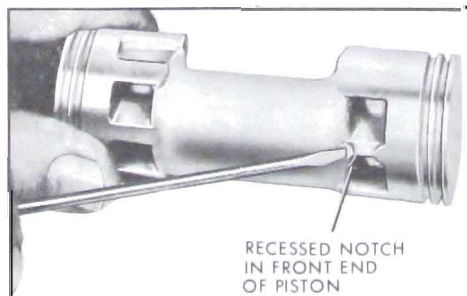

Figure 11-128—Piston Assembly

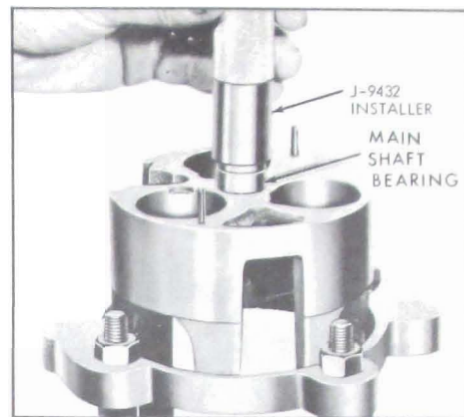

Figure 11-129—Installing Main Shaft Bearing

cylinder bores are deeply scored or damaged.

16. Examine the mainshaft bearings. There is one in each cylinder half. If a bearing is damaged, remove bearing with a suitable socket or punch. Install new bearing with J-9432 so that lettering on bearing is toward outside of cylinder half. See Figure 11-129.

d. Adjusting Compressor Shaft End Play and Piston Shoe Disc Clearance

IMPORTANT: The following operations are required when it is practical to replace an internal part or parts of the cylinder assembly. If the complete cylinder assembly is replaced, gauging of the shaft end play and shoe disc clearance is not required.

1. Secure four zero thrust races, three zero shoe discs and two new thrust bearings.

2. Apply clean petroleum jelly to a zero thrust race, a new needle thrust bearing and a second zero thrust race. Assemble this "sandwich" of parts to front end of compressor mainshaft.

3. Place FRONT half of cylinder on J-9397 Fixture. Insert threaded end of shaft (with front thrust bearing assembly) through front cylinder half and allow thrust race assembly to rest on

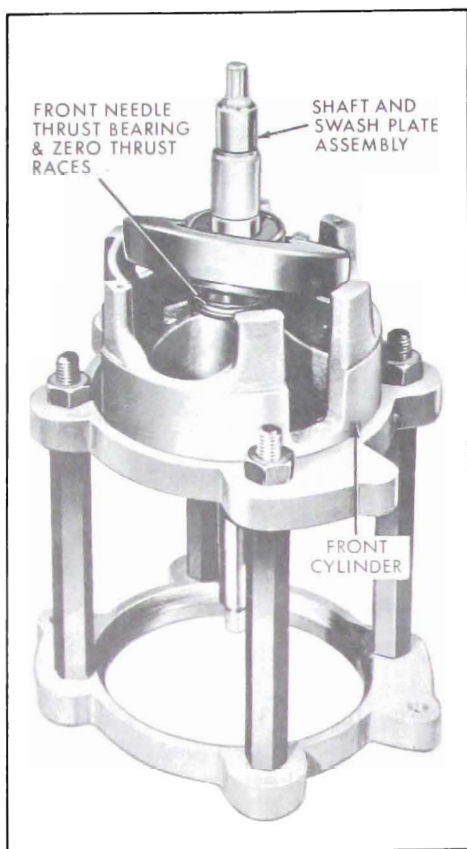

Figure 11-130—Shaft Assembly and Front Needle Thrust Bearing and Races in Front Cylinder Half

hub of cylinder. See Figure 11-130.

4. Place a zero thrust race, a new thrust bearing and a second zero thrust washer on REAR of compressor mainshaft so it rests on hub of swash plate.

5. Lightly apply clean petroleum jelly to ball pockets of each of three pistons.

6. Place balls in piston pockets.

7. Lightly apply clean petroleum jelly to cavity of three new zero shoe discs.

8. Place a zero shoe over each ball in FRONT end of piston. Do not place shoes on piston rear balls.

NOTE: Do not assemble any piston rings on pistons at this time.

9. Rotate shaft and swash plate until high point of swash plate is over piston cylinder bore, which

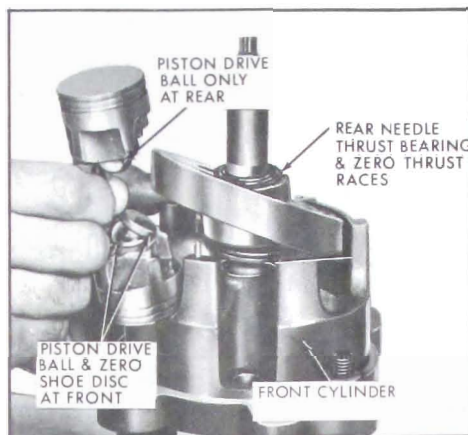

Figure 11-131—Installing Piston Assembly in Cylinder for Gauging

has been identified as No. 1. Insert front end of No. 1 piston (notched end) in cylinder bore (toward the front of compressor) and at same time, place front ball and shoe and rear ball only over swash plate.

IMPORTANT: It is necessary to lift shaft assembly when installing pistons. Hold front thrust bearing pack tightly against swash plate hub while lifting shaft.

10. Repeat this operation for No. 2 and No. 3 pistons. Balls and shoes must adhere to piston during this assembly.

11. Align rear cylinder half casting with bores, suction passage, discharge holes, dowel pins, etc. Tap into place, using a wood block and mallet. See Figure 11-132.

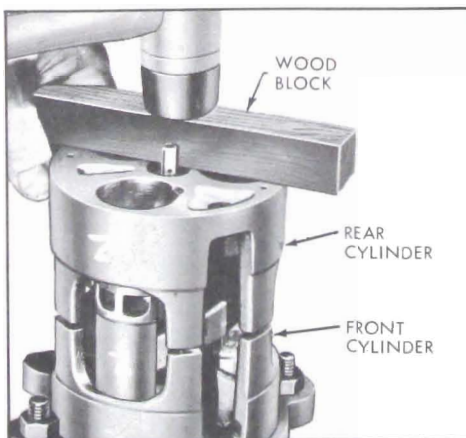

Figure 11-132—Assembling Rear Cylinder Half

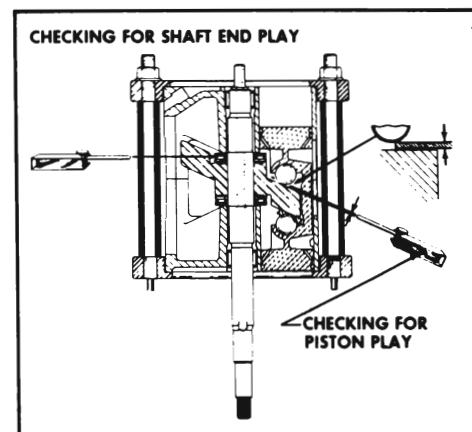

Figure 11-133—Checking Cylinder Clearances

12. Place cylinder assembly in J-9397 Compressing Fixture with front of compressor shaft pointing up, positioning discharge tube opening between fixture bolts. This will permit access for the feeler gauge. Assemble fixture head ring and nuts to the cage, tighten nuts evenly to 15 lb. ft. torque.

13. Use a leaf-type feeler gauge to check clearance between REAR ball and swash plate for each piston.

(a) Use a suitable combination of feeler gauge leaves until the combination will result in a satisfactory "feel" between ball and swash plate. See Figures 11-133 and 134.

(b) After a suitable combination of feeler gauge leaves have been

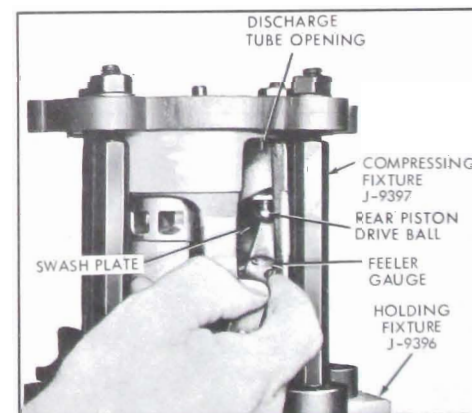

Figure 11-134—Gauging Clearance Between Rear Drive Ball and Swashplate

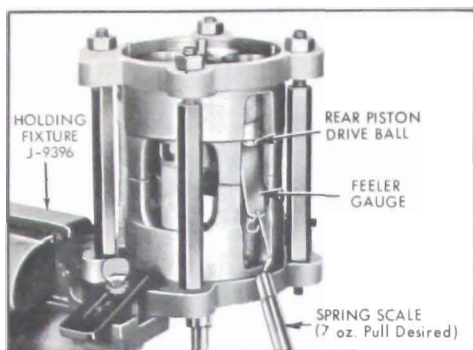

Figure 11-135—Checking Selected Feeler Gauge with Spring Scale

selected for a satisfactory “feel” between the rear ball and swash plate as instructed in Step (a), attach a spring scale to end of feeler leaf. Spring scale must be calibrated in ounces, such as Generator brush tension scale J-5164 or spring scale used for checking distributor point spring tension. Insert the selected feeler leaf between rear ball and swashplate, then pull straight out on spring scale with a steady, even pull being sure feeler does not bend or kink. See Figure 11-135. Record reading on scale. Spring scale must be read while feeler is moving. If selected feeler is correct size, spring scale will read between 4 and 8 ounces (the higher reading is desired). If reading is not within limits, select the next .0005” smaller or larger feeler leaf and repeat spring scale check until proper reading is obtained. Then proceed with Steps (c), (d), (e), (f), and (g) checking selected feeler leaf drag with spring scale at each location. The cylinder parts and feeler leaves must be very clean and coated with 525 viscosity compressor oil.

NOTE: By using the spring scale to check the selected feeler leaves, a standard may be set up as to the amount of feeler leaf drag required to properly rebuild the compressor. Also, the size of the numbered shoe discs and thrust bearing races for service has been determined by using the spring scale method of checking feeler leaf drag.

(c) Rotate the shaft approximately 120° and make a second check with feeler gauge between same ball and plate.

(d) Rotate shaft again approximately 120° and repeat check with feeler gauge between these same parts.

(e) From this total of three checks between the same ball and swash plate at 120° increments on swash plate, use the minimum feeler gauge reading to select a numbered shoe to correspond to this reading. See Example below.

Example:

	Position 1	Position 2	Position 3
Piston #1	.019	.020	.019
	Select and use a No. 19 Shoe		
Piston #2	.020	.020	.020
	Select and use a No. 20 Shoe		
Piston #3	.021	.020	.021
	Select and use a No. 20 Shoe		

SHOE DISC CHART	
Service Part Number	Identification No. Stamped on Shoe Disc
6557000	0
6556175	17-1/2
6556180	18
6556185	18-1/2
6556190	19
6556195	19-1/2
6556200	20
6556205	20-1/2
6556210	21
6556215	21-1/2
6556220	22

(f) Mark piston number “1,” “2” or “3” on selected shoe package and place in corresponding position in parts tray.

(g) Repeat the above procedure on the other two pistons.

14. The next gauging operation is to determine space between REAR thrust bearing and rear outer thrust race.

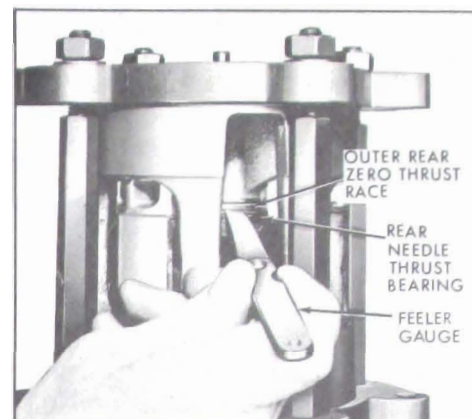

Figure 11-136—Gauging Clearance Between Rear Needle Thrust Bearing Rear Outer Race

(a) Use a suitable combination of feeler gauge leaves to get a satisfactory “feel” between these two parts. See Figure 11-136.

(b) The spring scale method should also be used to check the drag of the feeler leaf that has been selected for clearance between rear thrust bearing and rear outer race. See Figure 11-137. The reading on the spring scale when pulling feeler leaf between these parts also should be between 4 and 8 ounces (the higher reading is desired). If reading is not within limits, select the next smaller or larger feeler leaf and repeat spring scale drag check until proper reading is obtained.

(c) Select from stock a numbered thrust race that corresponds to

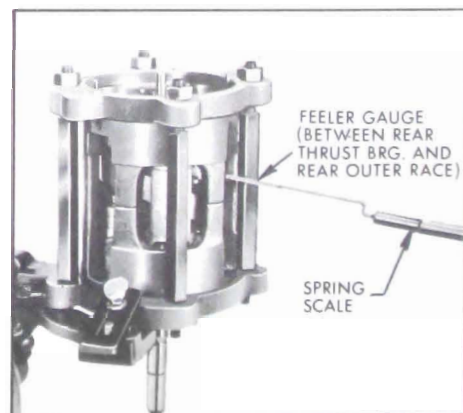

Figure 11-137—Checking Selected Feeler Gauge with Spring Scale

feeler gauge reading. For example, if feeler gauge reading is .009", a race with a number "9" stamped on it should be selected and be installed in place of the rear outer race.

THRUST BEARING RACE CHART	
Service Part Number	Identification No. Stamped on Race
6556000	0
6556060	6
6556065	6-1/2
6556070	7
6556075	7-1/2
6556080	8
6556085	8-1/2
6556090	9
6556095	9-1/2
6556100	10
6556105	10-1/2
6556110	11
6556115	11-1/2
6556120	12

(d) Mark the selected REAR thrust race and place it in the J-9402 assembly parts tray corresponding to its position.

15. Remove cylinder assembly from J-9397 compressing fixture.

16. Separate cylinder halves. It may be necessary to use a fiber block and mallet.

17. Remove rear half cylinder.

18. Carefully remove one piston at a time from swash plate and front half cylinder. Do not lose relationship or position of front ball and shoe, and rear ball. Transfer each piston, balls and shoe assembly to their proper place in the J-9402 assembly tray.

19. Remove REAR outer zero thrust race from shaft and replace it with selected numbered thrust race, determined in Step No. 14. Apply a light coat of

petroleum jelly to thrust races to aid in holding them in place during assembly.

NOTE: This zero thrust race may be put aside for re-use in additional gauging and/or rebuild operations.

e. Assembly of Compressor Cylinder Assembly

Be sure to install all new seals and "O" rings and to lubricate all the parts generously with 525 compressor oil during assembly.

1. Assemble a piston ring, scraper groove toward the outside of piston, to each end of the three pistons.

2. Apply a light coat of petroleum jelly to selected numbered shoes and place them over correct ball in rear of piston.

3. With front and rear thrust bearing assemblies on shaft and shaft installed in front cylinder half, rotate swash plate so high point is above cylinder bore No. 1. Carefully assemble No. 1 piston (complete with ball and zero shoe on FRONT end, and ball and numbered shoe on REAR end) over swash plate. See Figure 11-138. Position piston rings so that the gap is toward center of cylinder. Compress and enter piston ring into front half cylinder. Repeat

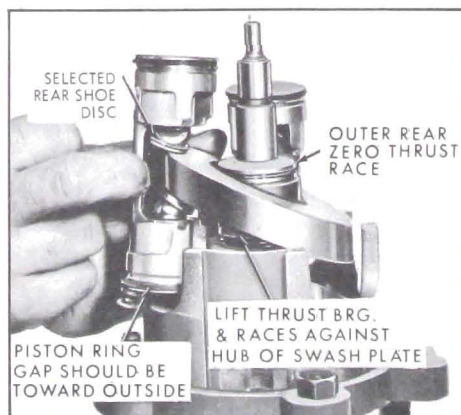

Figure 11-138—Installing Piston in Cylinder Assembly

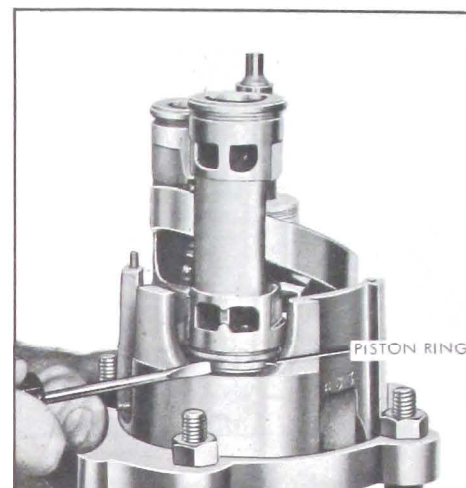

Figure 11-139—Compressing Front Piston Ring

this operation for pistons No. 2 and No. 3. See Figure 11-139.

4. Assemble one end of service discharge tube into hole in front cylinder. See Figure 11-140.

5. Rotate shaft to position pistons in a "stair step" arrangement. See Figure 11-141. Position piston ring gaps toward outside of cylinder. Place rear half cylinder over shaft and start pistons into cylinder bores.

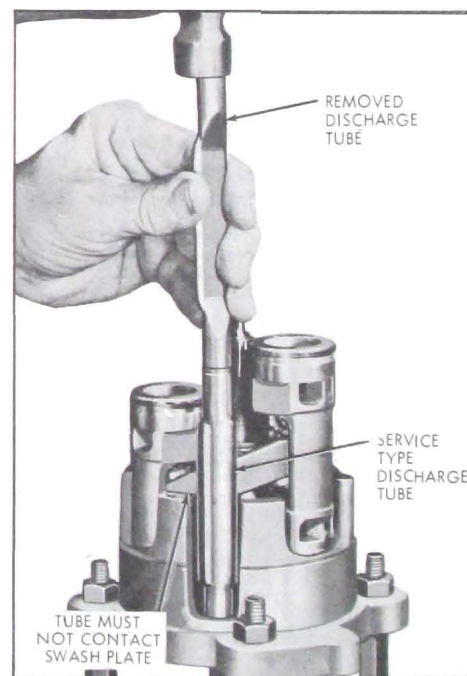

Figure 11-140—Installing Service Type Discharge Tube



Figure 11-141—Pistons Positioned in "Stair Step" Arrangement

(a) Compress piston ring on each piston so as to permit its entrance into cylinder. See Figure 11-142. If ring is not properly compressed when installing rear cylinder half, ring will be broken.

(b) When all three pistons and rings are in their respective cylinders, align end of the discharge tube with hole in rear half cylinder, making sure flattened portion of this tube faces inside of compressor for swash plate clearance.

(c) When satisfied that all parts are in proper alignment, tap with a fiber block and mallet to "seat" rear cylinder over locating dowel pins.

6. Generously lubricate all moving parts with clean Frigidaire

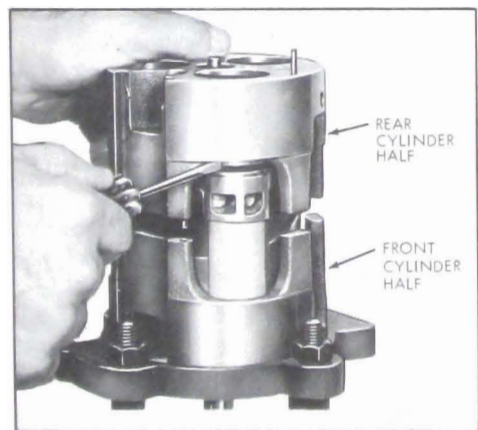

Figure 11-142—Compressing Rear Piston Ring

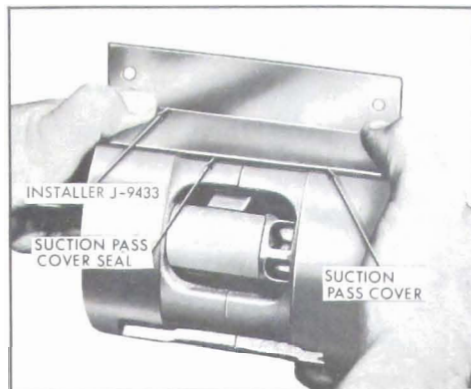

Figure 11-143—Installing Suction Pass Cover and Seal

525 viscosity oil. Check for free rotation of swashplate.

7. Assemble a new rectangular seal to suction pass cover.

(a) Coat seal with clean 525 viscosity oil.

(b) Start one side of seal and cover into "dove tail" slot in the cylinder.

(c) Use J-9433 suction pass cover seal installer as a "shoe horn", by placing it between the seal on opposite side and the "dove tail" slot. See Figure 11-143.

(d) Center cover and seal with ends of cylinder faces.

(e) Press down on cover to snap it into place.

(f) Remove J-9433 installer as shown in Figure 11-144.

(g) Examine cover and seal to be sure cover is properly seated and seal is not damaged.

8. If necessary to replace a locator pin, use suitable pliers to



Figure 11-144—Removing Installer J-9433

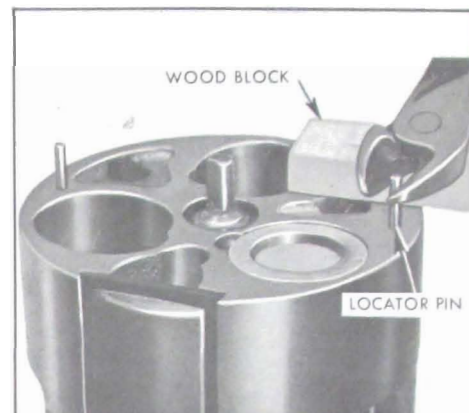

Figure 11-145—Removing Locator Pin

remove pin, using care not to damage surface of cylinder. See Figure 11-145. Install new pin, carefully tapping it into place.

f. Front Head and Cylinder Assembly Installation

1. Install discharge tube front "O" ring and bushing. See Figure 11-146.

2. Assemble front suction valve reed disc to front end of cylinder. Align dowel pin holes, suction ports and oil return slot. See Figure 11-147.

3. Assemble front discharge valve plate, aligning holes with dowel pins and proper openings in head. See Figure 11-148.



Figure 11-146—Installing Discharge Tube "O" Ring and Bushing

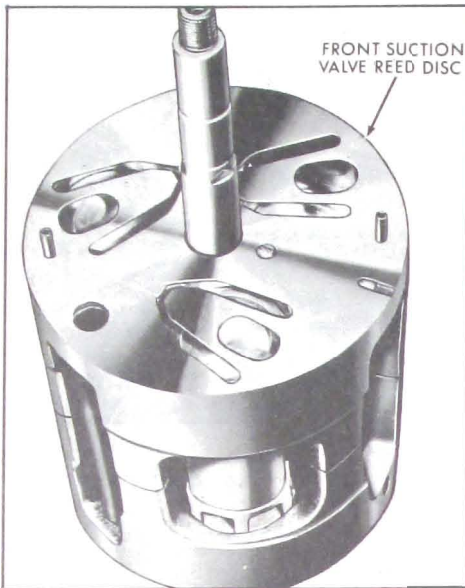

Figure 11-147—Front Suction Valve Reed Disc Installed

4. Coat teflon gasket surfaces on webs of compressor front head casting with clean 525 viscosity compressor oil.

5. Examine location of dowel pins and contour of webs and mark dowel location on head with pencil as shown. Use care to avoid damaging teflon surfaces. See Figure 11-148. When in proper alignment, seat on front discharge valve plate with light mallet taps.

6. Place compressor shell with J-9396 holding fixture in vise so rear end of shell is up.



Figure 11-148—Installing Front Head on Cylinder Assembly

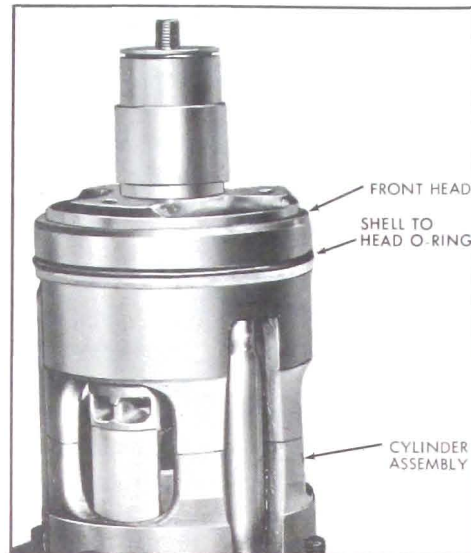

Figure 11-149—Front Head Installed on Cylinder Assembly

7. Install a new shell to head "O" ring on shoulder at rear of front head. See Figure 11-149.

8. Apply 525 viscosity oil on the "O" ring and surfaces of the front head.

9. Coat the inside machined surfaces of shell with clean 525 viscosity compressor oil. Line up oil sump with oil intake tube hole and lower mechanism into shell. Extreme care must be used to prevent large "O" ring seal from being damaged. Maintain this alignment when lowering mechanism into place. See Figure 11-150.

10. Place "O" ring on the oil inlet tube; apply oil to cavity and "O" ring. Insert tube and "O" ring, rotating compressor mechanism as necessary and align tube with hole in the shell baffle. Be sure "O" ring and inlet tube are properly seated.

11. Install discharge "O" ring and bushing.

g. Oil Pump and Rear Head Installation

1. Position rear suction valve reed disc to align with dowel pins, reed tips, and ports in head.

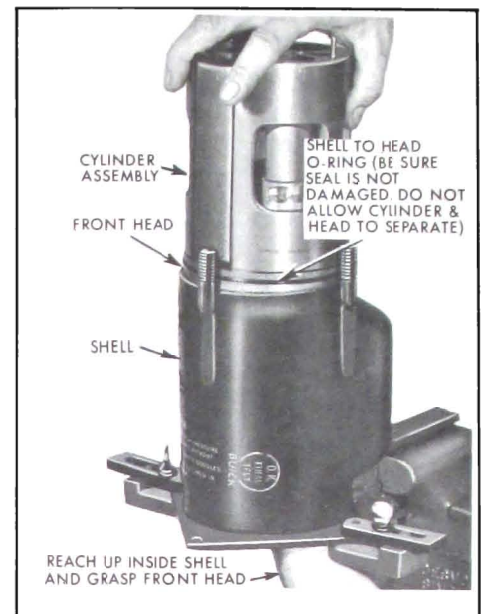

Figure 11-150—Installing Cylinder Assembly into Shell

2. Position rear discharge valve plate to align with dowel pins and ports and slide it into place over locator pins.

3. Assemble the inner oil pump rotor over the "D" shaped flat on the shaft. Place outer oil pump rotor over inner oil pump rotor. If original gears are used, be sure gears are installed in their original positions.

4. Generously oil valve plate around outer edge where large

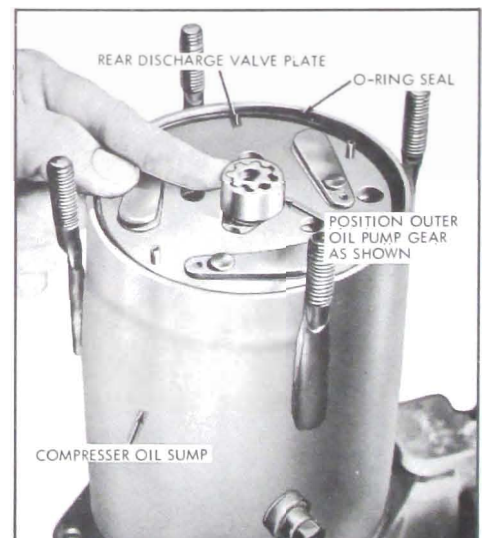

Figure 11-151—Positioning Oil Pump Outer Rotor



Figure 11-152—Installing Rear Head

“O” ring will be placed. Oil valve reeds, oil pump rotors, and area where teflon gasket will contact valve plate.

5. Coat new shell to head “O” ring with oil and place it on rear discharge valve plate in contact with shell.

6. Place suction screen in rear head if removed.

7. Position the oil pump outer rotor as shown in Figure 11-151.

8. Assemble rear head to shell, using care not to damage the teflon sealing surfaces on head.

NOTE: If locator pins do not engage hole in rear head, grasp front head and slightly rotate cylinder assembly. See Figure 11-152.

9. Assemble new nuts to threaded shell studs and tighten to 20 lb. ft. torque.

10. Replace pressure relief valve, if removed, using new copper washer.

11. Place new “O” rings on discharge and suction ports in

compressor. Assemble charging line Adapter Plate J-9527 to compressor.

12. Invert compressor and compressor holding fixture in vise.

13. Install shaft seal assembly. Paragraph 11-16, subparagraph “h”.

NOTE: When checking compressor for leaks as instructed in seal installation, it is also recommended to check for internal leaks as follows:

With gauge set attached to compressor as shown, pressurize discharge side of compressor only. If the same pressure is immediately noted on the suction side gauge as on the discharge gauge, it indicates an internal leak such as head teflon sealing surface, discharge tube, to shell head “O” ring seal or reed valves. Also observe the reading on the high pressure gauge with shut-off valves closed. If gauge reading drops more than 10 pounds in 30 seconds, it indicates an internal leak in compressor.

14. Depressurize compressor and correct any leaks as necessary.

15. Remove charging line adapter plate from compressor and install end plate.

16. Refer to paragraph 11-15, subparagraph “j” for amount of 525 compressor oil to install in compressor. The oil is installed through oil drain screw opening.

17. Install coil and housing assembly. Paragraph 11-16, subparagraph “f”.

18. Install pulley assembly and bearing. Paragraph 11-16, subparagraph “d”.

19. Install clutch drive plate. Paragraph 11-16, subparagraph “b”.

11-18 EVACUATION, LEAK TESTING AND CHARGING OF AIR CONDITIONER

Tool J-8393 Portable Air Conditioner Service Station is a Kent-Moore unit designed specifically for servicing automobile air conditioners. J-8393 provides a means of measuring refrigerant without the use of scales. The unit also makes it possible to charge a system without heating the refrigerant tank. As complete instructions are printed on the control panel of J-8393 and the instructions differ from those used with conventional equipment, only conventional equipment will be considered in the paragraph.

a. Evaluation and Leak Testing of System

1. Attach gauge lines, adapters and vacuum pump set-up as shown in Figure 11-153 and discharge any refrigerant that may be in system.

2. Start the vacuum pump, open both valves on gauge set, then slowly open the shut-off valve on the vacuum pump.

CAUTION: If valve on the vacuum pump is opened too quickly, oil may be forced out of pump.

3. Operate vacuum pump until at least 28 inches vacuum (at sea level) is registered on the Low pressure gauge, then continue to run pump for at least ten minutes.

NOTE: Allowance should be made for elevation when obtaining a vacuum. A vacuum of 28 inches of mercury at or near sea level is required. For higher levels, the required vacuum may be reduced by 1 inch of mercury for each 1,000 feet of elevation.

4. If a 28 inch vacuum cannot be obtained, close pump shut-off valve and stop pump, then open the refrigerant-12 cylinder valve

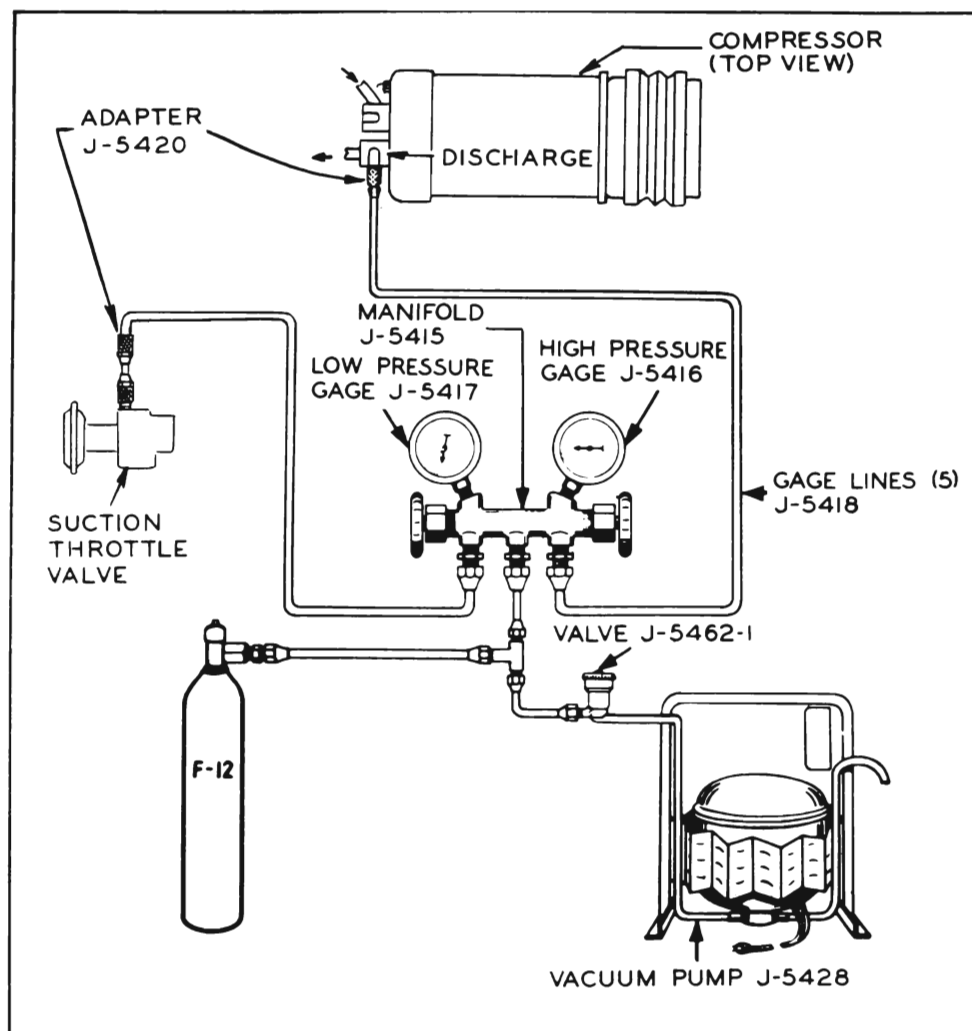

Figure 11-153—Setup for Evacuating, Leak Testing and Charging System

to charge the system at cylinder pressure. After closing the cylinder valve, leak test the complete system including gauge connections and correct any leaks found. Then re-evacuate system.

5. After 28 inches of vacuum has been maintained for ten minutes, close the vacuum pump shut-off valve and stop the pump. Observe gauge and if loss of vacuum is 2 inches or more in 5 minutes, there is a leak in the system and must be corrected.

6. If system checks out, charge the system with refrigerant-12 at cylinder pressure. Then with refrigerant-12 cylinder valve closed, again evacuate the system with pump at 28 inches of vacuum for ten minutes. This charging and

second evacuation is for the purpose of removing any air or moisture that may have entered the system.

7. After maintaining the 28 inches of vacuum for ten minutes, close the vacuum pump shut-off valve and stop the pump. The refrigerant system is now ready for charging.

b. Charging the System

1. With the vacuum pump, refrigerant-12 cylinder and gauge set connected to the compressor as shown in Figure 11-153, place the cylinder in a bucket of hot water which does not exceed 125°F.

CAUTION: Never heat refrigerant cylinder above 125°F. as tremendous hydrostatic pressures will develop, capable of rupturing

cylinder. When there is a possibility of overheating cylinder, the cylinder must be opened to a suitable pressure relief mechanism at all times.

2. Place cylinder and bucket on a suitable scale and record the total weight.

3. Open the low pressure valve on the gauge set. (High pressure valve on the gauge set closed.)

4. Wearing goggles to protect eyes, fully open the refrigerant-12 cylinder valve and allow refrigerant-12 vapor to flow into the refrigerating system.

5. Operate engine and compressor at slow idling speed until a total of 4-1/4 pounds of refrigerant-12 have been charged into the 45000, 46000 and 48000 Series system or 3-3/4 pounds of refrigerant-12 in the 49000 Series system. It may be necessary to reheat the water in bucket to maintain required pressure.

6. Close both valves on gauge set, close valve on refrigerant-12 cylinder, and remove cylinder from bucket of water.

IMPORTANT: Whenever the refrigerant system is discharged and recharged, it is necessary to cycle the suction throttle valve several times to normalize the piston diaphragm in the valve. This is done on the 49000 by moving the air conditioner temperature control lever from one extreme to the other.

On the 45000, 46000 and 48000, operate WARMER lever several times.

7. Perform functional test, paragraph 11-19.

8. After test is completed, remove gauge lines and replace protective caps over Schrader valve fittings and tighten securely.

11-19 AIR CONDITIONER FUNCTIONAL TEST

In order to determine if the air system is operating properly and efficiently, it should be functional tested. Functional testing the air conditioner is determining if the discharge air temperature at the air outlet located at right side of the instrument panel, suction pressure and discharge pressure are within the specifications at a particular ambient condition. See Figures 11-154 and 11-155.

11-20 AIR CONDITIONER TROUBLE DIAGNOSIS

NOTE: If a case is encountered on a 49000 Series where the air conditioner has a refrigerant leak and there has been difficulty detecting it, there is a possibility that the piston diaphragm in the suction throttling valve may be the cause of the leak. If the piston diaphragm is leaking, the refrigerant will be drawn into the engine intake manifold through the vacuum hose and there will be no indication that the suction throttle valve has an external leak. Thus, when checking the air conditioner system for leaks, remove the vacuum hose from the suction throttle valve vacuum diaphragm, wait several seconds to allow refrigerant to collect in the diaphragm and leak test at the vacuum hose connection on the diaphragm. If leak detector indicates a leak, it will be necessary to remove suction throttle valve and replace the piston diaphragm in the valve.

a. Inspection of Air Conditioner System

1. Check compressor belt tension. See Figures 2-47 and 2-48.
2. Inspect all connections for presence of oil on any of the refrigerant system parts which could indicate a refrigerant leak.

If oil is evident, check for leaks and repair as necessary.

3. Check air outlet hoses for leaks or restrictions.

4. Check outer surface of condenser to be sure they are not plugged with dirt, leaves or other foreign material. Be sure to check between the condenser and radiator as well as the outer surfaces.

5. Check to insure the evaporator drains are open.

6. Check sight glass as instructed in subparagraph "c".

7. Check ambient air temperature and air temperature at right air outlet following instructions on functional test charts. See Figures 11-154 and 11-155. Temperature should correspond with those listed on chart. If temperatures do not compare, attach gauge set (Figure 11-153) and functional test air conditioner.

b. Diagnosis of Components

Listed below are the air conditioner components and the possible conditions that could be encountered with each unit if defective.

1. **Compressor** - Compressor malfunction will appear in one of four ways: noise, seizure, leakage, or low discharge pressures. Even resonant compressor noises are not cause for alarm; however, irregular noises or rattles are likely to indicate broken parts.

Seizure will be indicated by the failure of the compressor to operate, if the clutch is in good operating condition, and there is no break in the electrical continuity of the system. Continued operation of a seized or partially seized compressor will result in damage to the clutch. To check for seizure, de-energize the clutch and attempt to rotate the compressor shaft. If the shaft will not turn, the compressor is

seized. Leakage of compressor refrigerant may be detected through routine leak detection.

Low discharge pressures may also be caused by insufficient refrigerant or a restriction elsewhere in the system. These should be checked out prior to compressor servicing.

2. **Compressor Clutch** - If the compressor is inoperative, the electrical wires to the clutch should first be checked. If there is current to the clutch and the compressor is not seized, the clutch is defective and should be repaired.

3. **Condenser** - There are two types of possible condenser malfunctions. The condenser may leak, resulting in loss of refrigeration and low system pressures, or the condenser may have a restriction, resulting in excessive compressor discharge pressures, and inadequate cooling. If a restriction occurs and some refrigerant passes the restriction, icing or frost may occur on the external surface of the condenser in the area of the restriction. Also if the air flow through the condenser is restricted or blocked, high discharge pressures will result. It is important that the external fins of the condenser and radiator core are not plugged with bugs, dirt, etc.

4. **Expansion Valve** - If malfunction of the valve is suspected, make sure the power element bulb is in proper position, tightly attached, and well insulated from outside air temperatures. If this valve fails, it usually fails in the power element and thus the valve remains closed. This will be indicated by low suction and discharged pressures. Also the inlet screen could be plugged. The screen may be cleaned with liquid refrigerant.

TEST CONDITIONS 45000, 46000 and 48000 Series

1. Car doors and hood open.
2. Climate control switch set at RECIR. and FAN lever full HI.
3. WARMER and DEFROST levers in off (fully left) position. Vent knobs off.
4. All air conditioner outlets open.
5. Gauge set connected to Schrader valve fittings as shown in figure 11-153.
6. Test should be conducted in area with above 70 F. ambient temperature.
7. Ambient air temperature should be measured in immediate test area toward front of car.
8. A fan should be used in front of radiator grille to insure minimum differential between temperature of air passing over condenser through radiator grille and evaporator through body cowl screen.

TEST NO. 1

Set engine speed at 2,000 rpm.

The following table lists ambient temperature, evaporator and compressor head pressures, and right and left air outlet temperatures that can be expected from a normally functioning unit.

NOTE: If evaporator pressure is not correct for indicated ambient temperature, adjust suction throttle valve following procedure in par. 11-15, sub-par. "f".

NOTE: The lower outlet temperature can be achieved on dry days, and the higher on humid days.

Ambient Temperature (°F)	Evaporator Pressure at Suction Throttling Valve (PSIG)	Compressor Head Pressure (PSIG)	Left Outlet Temperature (°F)	Right Outlet Temperature (°F)
70	28-30	160-195	38-41	39-43
80	28-30	180-235	40-43	40-45
90	28-30	200-280	40-45	40-45
100	28-30	230-310	42-47	42-48
110	28-31	270-335	44-52	46-53

TEST NO. 2:

This should be run on cars which will pass Test No. 1, but do not perform satisfactorily on the road. In this test the engine speed should be adjusted to the ambient temperature and humidity.

Ambient Temperature (°F)	Relative Humidity	Engine R.P.M.	Evaporator Press at Suction Throttling Valve (PSIG)	Compressor Head Pressure (PSIG)	Left Outlet Temperature (°F)	Right Outlet Temperature (°F)
70	Dry	410-435	28	120	40	40
70	Humid	450-475	35	148	46	47
80	Dry	400-435	31	156	44	44
80	Humid	690-715	35	200	50	50
90	Dry	415-440	35	178	47	47
90	Humid	765-790	35	225	51	54
100	Dry	620-670	35	225	48	48
100	Humid	950-1000	35	267	54	56
110	Dry	775-825	35	260	50	50
110	Humid	1225-1275	35	317	55	56

The pressures and outlet temperature should be equal to or lower than those tabulated above.

Figure 11-154—Air Conditioner Functional Test - 45000, 46000 and 48000 Series

Test Conditions - 49000 Series

1. Car windows and hood open, doors closed.
2. Air Conditioner Temp. and Air levers set at maximum cooling position.
3. All Air Conditioner outlets open.
4. Gage set connected to Schrader valve fittings as shown in Figure 11-153.
5. Heater defroster and ventilator controls in OFF position.
6. Test should be conducted in area with above 70°F. ambient temperature.
7. Ambient air temperature should be measured in immediate test area toward front of car.
8. A fan should be used in front of radiator grille to insure minimum differential between temperature of air passing over condenser through radiator grille and evaporator through body cowl screen.

Test No. 1: -49000 Series

Set engine speed at 2000 rpm.

The following table lists ambient temperature, evaporator and head pressures and right air outlet temperatures that can be expected from a normally-functioning unit.

NOTE: If evaporator pressure is not correct for indicated ambient temperature, adjust suction throttle valve following procedure in par. 11-15, sub-par. f.

NOTE: The lower outlet temperature can be achieved on dry days, and the higher on humid days.

Ambient Temperature °F	Evaporator Pressure PSIG	Compressor Head Pressure PSIG	Rt. Outlet Temperature °F
70	20-22	160-190	37-41
80	20-22	190-210	39-43
90	20-22	220-240	43-46
100	20-22	250-270	47-50
110	22-25	280-300	51-54

Test No. 2: -49000 Series

This should be run on cars which will pass Test No. 1, but do not perform satisfactorily on the road. In this test the engine speed should be adjusted to the ambient temperature and humidity.

Ambient Temperature °F	Humidity	Engine R.P.M.	Evaporator Pressure PSIG	Compressor Head Pressure PSIG	Right Outlet °F
70	Dry	500-525	26	122	36
70	Humid	500-525	26	138	38
80	Dry	525-550	26	155	41
80	Humid	675-700	26	190	45
90	Dry	725-750	26	200	44
90	Humid	975-1000	26	220	48
100	Dry	1000-1025	26	230	46
100	Humid	1100-1125	26	245	49
110	Dry	1200-1225	26	260	49
110	Humid	1675-1700	26	285	54

Figure 11-155—Air Conditioner Functional Test - 49000 Series

5. Evaporator - Dirt or other foreign matter on the core surface or in the evaporator case will restrict air flow. A cracked or broken case can result in insufficient air or warm air delivered to the passenger compartment. The condensation drains should be unrestricted.

6. Receiver Dehydrator - Leakage of refrigerant indicates a defective unit. The desiccant cannot easily be checked, but if it or the system has been exposed to outside air for a considerable length of time, the unit should be replaced.

Restrictions in the receiver-dehydrator can also cause system malfunction. If the inlet tube is blocked, it is likely to result in high head pressure. If the outlet tube is blocked, head pressure is likely to be low and there will be little or no cooling.

IMPORTANT: The IN stamped on receiver must be connected to the condenser.

7. Suction Throttle Valve (STV) - If the STV is defective it may cause evaporator pressure to be

too high (air outlet temperature too warm) or it could cause the evaporator pressure to be too low (air outlet temperature too low which may cause icing of the evaporator core). Also if the vacuum diaphragm of the STV is defective, there would be no means of setting the STV to change the air outlet temperature. Refrigerant leakage of STV may be detected through routine leak detection. Before servicing the suction throttle, it should be determined that the STV is actually the cause of the complaint by following adjustment procedure in paragraph 11-15, subparagraph "f".

If tests indicate STV is defective, it should be removed, disassembled and repaired following procedure in paragraph 11-15, subparagraph "g" and "h".

c. Use of Receiver Sight Glass for Diagnosis

At temperatures higher than 70°F., the sight glass may indicate whether the refrigerant charge is sufficient. A shortage of liquid refrigerant is indicated

after about five minutes of compressor operation by appearance of slow-moving bubbles (vapor) or a broken column of refrigerant under the glass. Continuous bubbles may appear in a properly charged system on a cool day. This is a normal situation. If the sight glass is generally clear and performance is satisfactory, occasional bubbles do not indicate refrigerant shortage.

If the sight glass consistently shows foaming or a broken liquid column, it should be observed after partially blocking the air to the condenser. If under this condition the sight glass clears and the performance is otherwise satisfactory, the charge shall be considered adequate.

In all instances where the indications of refrigerant shortage continues, additional refrigerant should be added in 1/4 lb. increments until the sight glass is clear. An additional charge of 1/2 lb. should be added as a reserve.

In no case should the system be overcharged.

COMPLAINT AND CAUSE	CORRECTION
<p>1. Insufficient Cooling</p> <p>(a) Low air flow</p> <p>(b) Defective heater core manual water valve</p> <p>(c) Heater, defroster, or ventilator controls not in the off position</p>	<p>(a) Check blower operation. Check for obstructions in air distribution system. Check for clogged evaporator. If iced, deice core and check adjustment and operation of suction throttle valve. Paragraph 11-15, subparagraph "f".</p> <p>(b) Check operation of valve. Adjust or replace as necessary.</p> <p>(c) Advise operator of correct operation of controls.</p>
<p>NOTE: If none of the above items are cause of complaint of insufficient cooling, perform functional test on car. If car does not pass test see items 2, 3, 4 and 5 on this chart.</p>	

COMPLAINT AND CAUSE	CORRECTION
<p>2. Compressor Discharge Pressure Too High</p> <p>(a) Engine overheated</p> <p>(b) Overcharge of refrigerant or oil in system</p> <p>(c) Restriction in condenser or receiver liquid indicator</p> <p>(d) Condenser air flow blocked</p> <p>(e) Evaporator pressure too high</p>	<p>(a) See Group 2 for possible cause.</p> <p>(b) Systems with excess discharge pressures should be slowly depressurized. (1) If discharge pressure drops rapidly, it indicates air (with possibility of moisture) in the system. When pressure drop levels but still indicates in excess of specifications shown in the FUNCTIONAL TEST CHART, slowly bleed system until bubbles appear in the sight glass and stop. Add refrigerant until bubbles clear, then add one-half pound of refrigerant. Recheck operational pressures. If system pressures still remain above specifications, and the evaporator pressure is slightly above normal, then a restriction exists in the high pressure side of the system. (2) If discharge pressure drops slowly, it indicates excessive refrigerant. If pressures drop to specifications and sight glass remains clear, stop depressurizing and recheck operational pressures. If pressures are satisfactory, depressurize until bubbles appear in the sight glass, stop depressurizing, then add one-half pound refrigerant. Recheck operational pressures. (3) If discharge pressure remains high after depressurizing the system, continue depressurizing until bubbles appear in the sight glass. If evaporator pressures also remain high, there is a possibility of a restriction in the high pressure side of the refrigeration system or the STV may require adjustment. See EVAPORATOR PRESSURE TOO HIGH.</p> <p>(c) Remove parts, inspect, and clean or replace.</p> <p>(d) Clean condenser and radiator core surfaces as well as the space between the condenser and radiator.</p> <p>(e) See EVAPORATOR PRESSURE TOO HIGH.</p>
<p>3. Compressor Discharge Pressure Too Low</p> <p>(a) Insufficient refrigerant</p>	<p>(a) Check for presence of bubbles or foam in liquid indicator. If bubbles or foam are noted (after five minutes of operation), check system for leaks, if no leaks are found refrigerant should be added until sight glass clears, then add an additional 1/2 lb.</p>

COMPLAINT AND CAUSE	CORRECTION
(b) Low suction pressure	(b) See EVAPORATOR PRESSURE TOO LOW.
(c) Defective compressor and/or broken compressor reed valves	(c) Repair compressor.
4. Evaporator Pressure Too High	
(This will be accompanied by air outlet temperature at outlet too high.)	
(a) Expansion valve capillary tube bulb not tight to evaporator outlet tube.	(a) Check for tightness.
(b) Expansion valve improperly adjusted or inoperative.	(b) Replace valve.
(c) Suction throttle valve adjusted improperly or defective	(c) Check operation of STV, paragraph 11-15, subparagraph "f". Repair valve, if necessary.
(d) Vacuum Modulator defective (49000)	(d) There should be no vacuum to STV when air conditioner temperature control lever on COOLER position and FAN switch lever on HIGH position. Replace vacuum modulator if defective.
5. Evaporator Pressure Too Low	
(a) Expansion valve capillary tube broken, inlet screen plugged or valve otherwise failed	(a) Replace valve or clean inlet screen of valve.
(b) Restriction in system tubes or hoses.	(b) Replace kinked tube or restricted hose.
(c) Suction throttle valve adjusted improperly or defective	(c) Check operation of STV, paragraph 11-15, subparagraph "f". Repair if necessary.
<p>NOTE: If compressor suction line from STV is extremely colder than STV inlet line from evaporator, this indicates that STV outlet pressure is much lower than inlet pressure and STV may be defective.</p>	

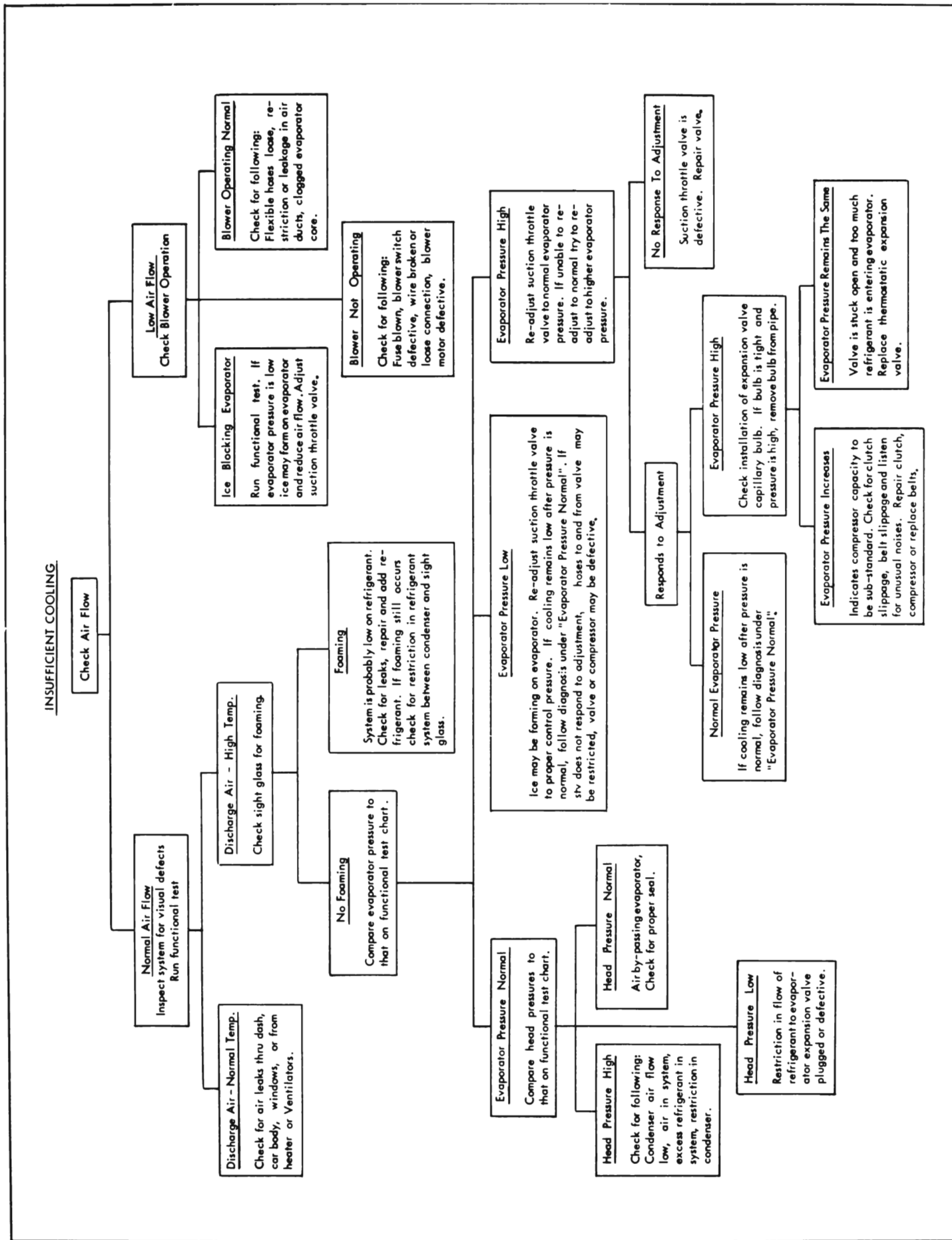

Figure 11-156—Air Conditioner Trouble Diagnosis Chart

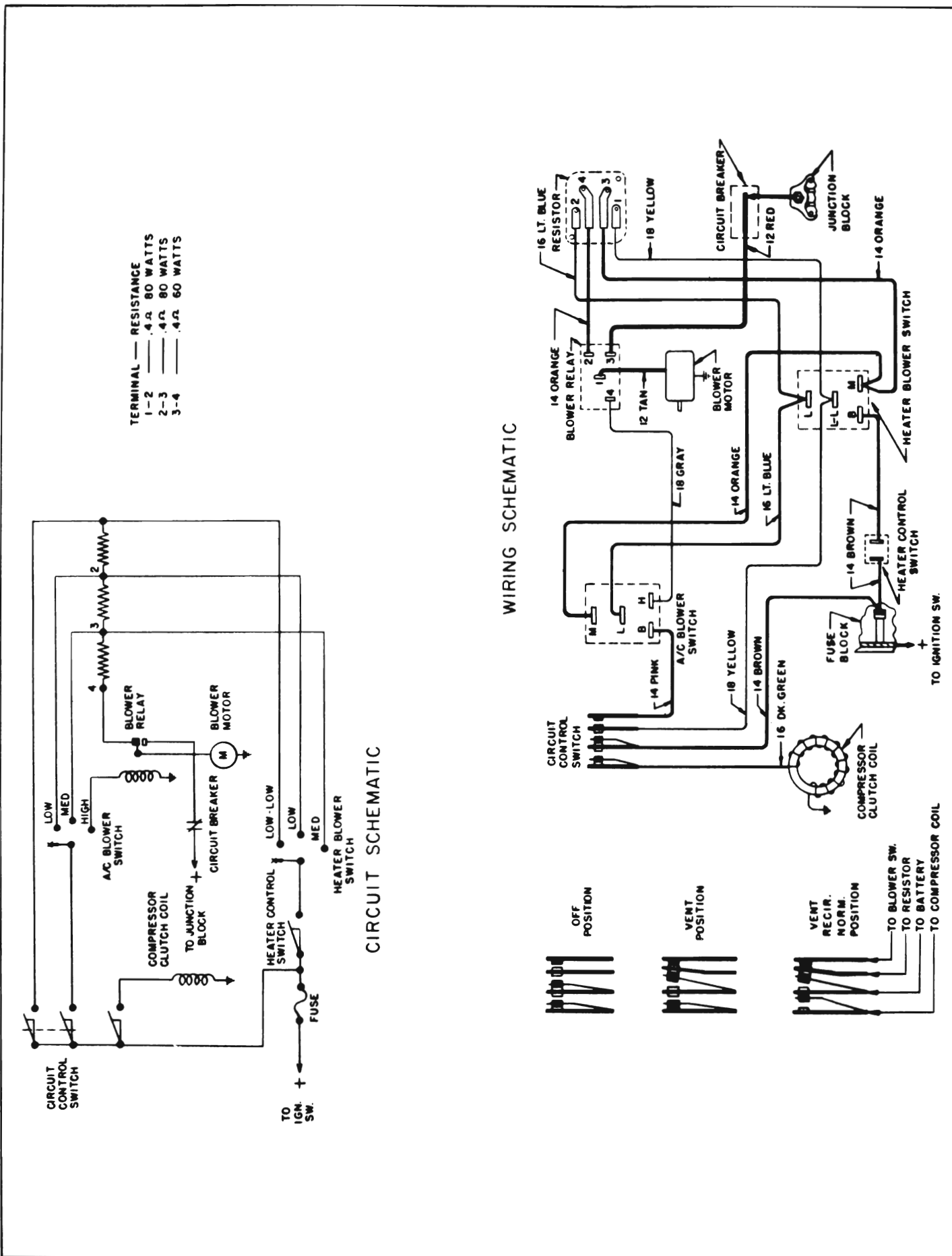

Figure 11-157—Heater-Air Conditioner Schematic - 49000 Series

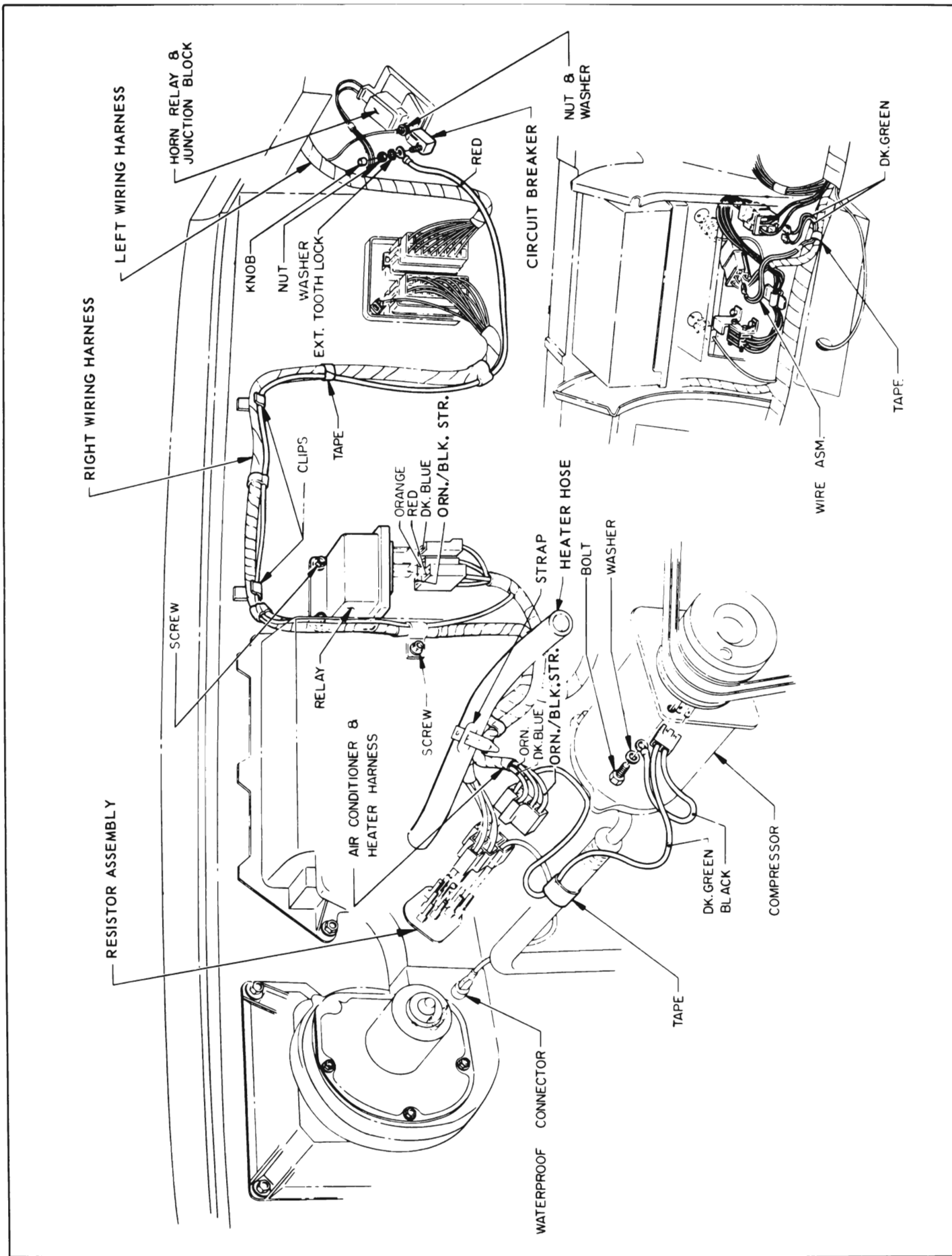

Figure 11-158—Heater-Air Conditioner Wiring Installation - 45000, 46000 and 48000 Series

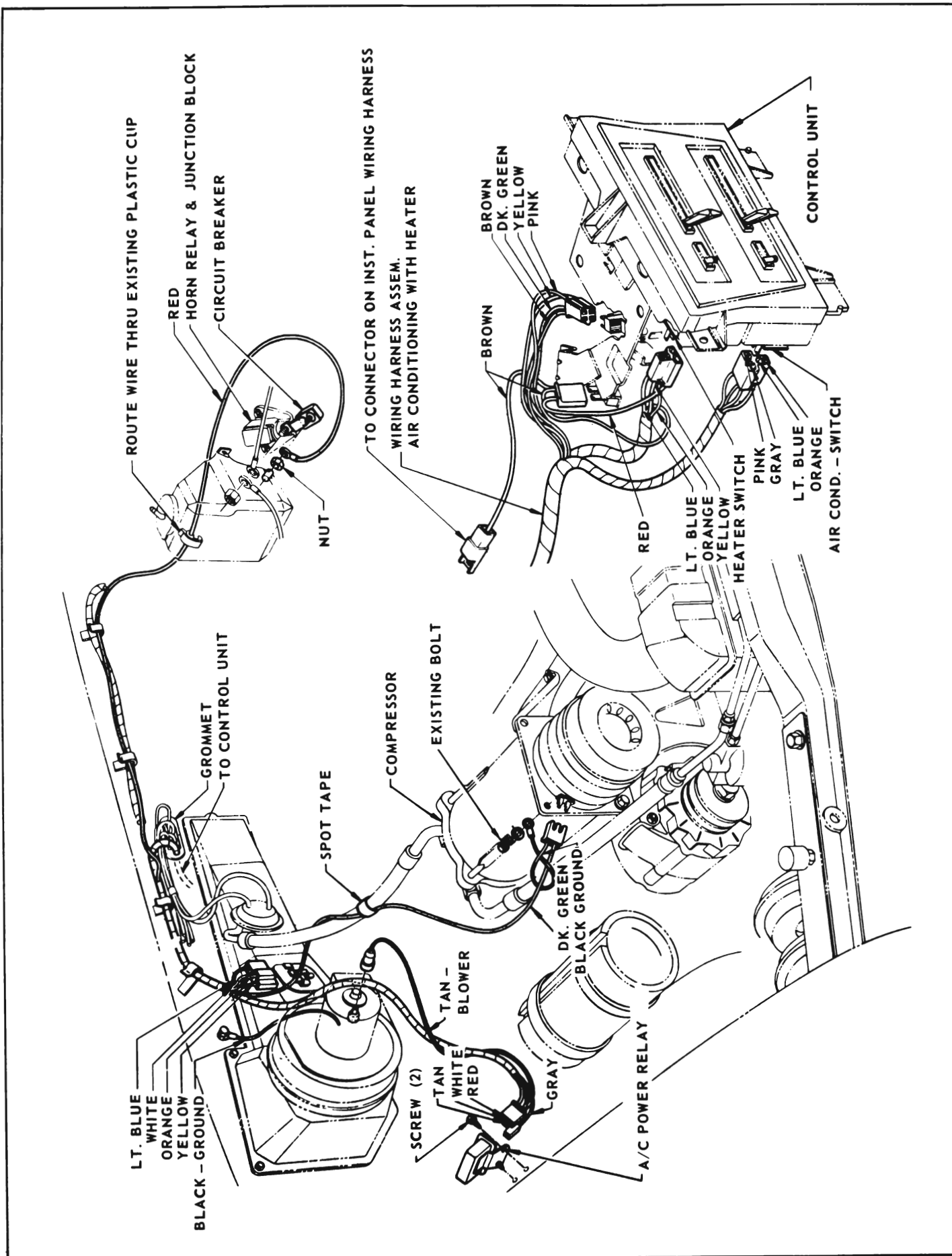

Figure 11-159—Air Conditioner Wiring Installation - 49000 Series

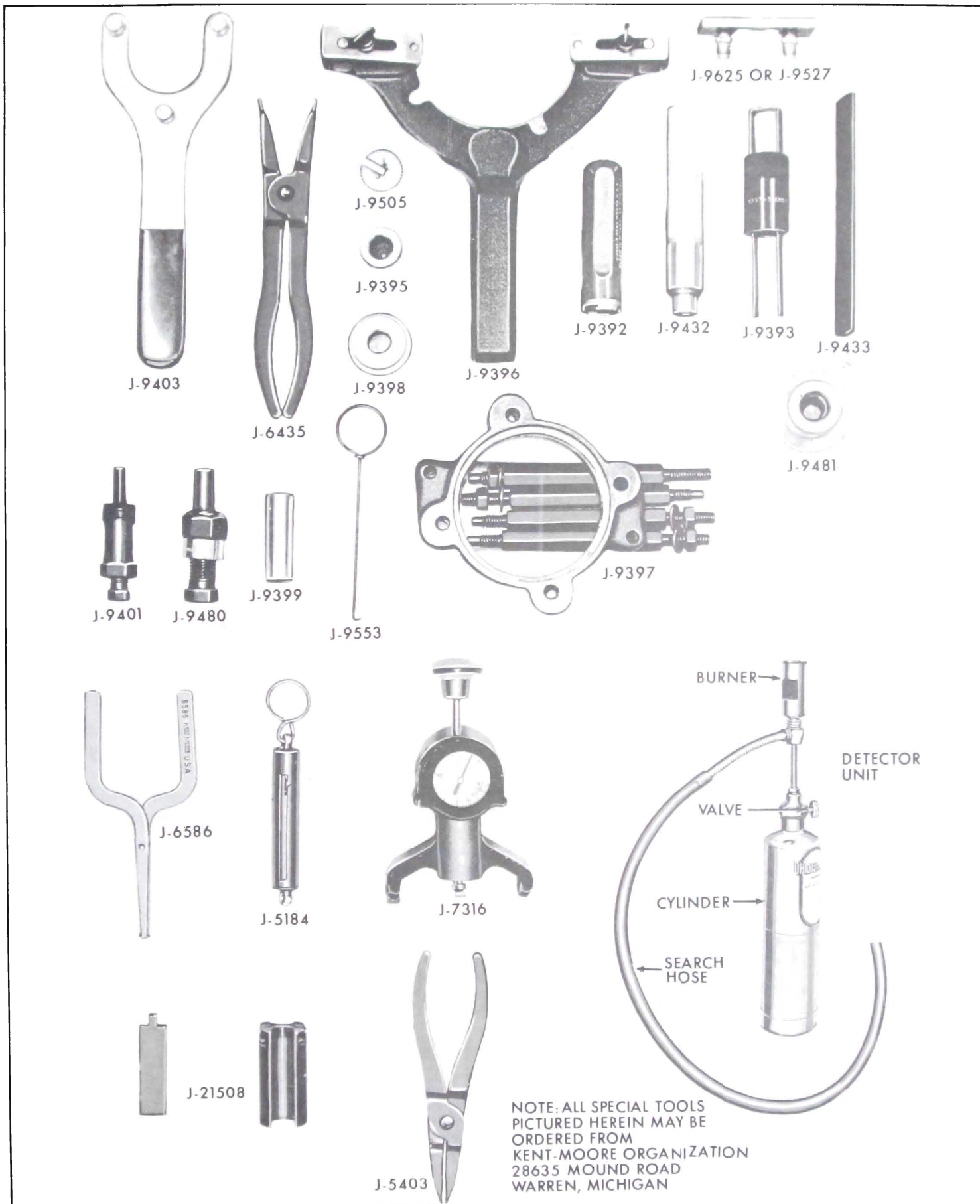

Figure 11-160—Air Conditioner Compressor Tools

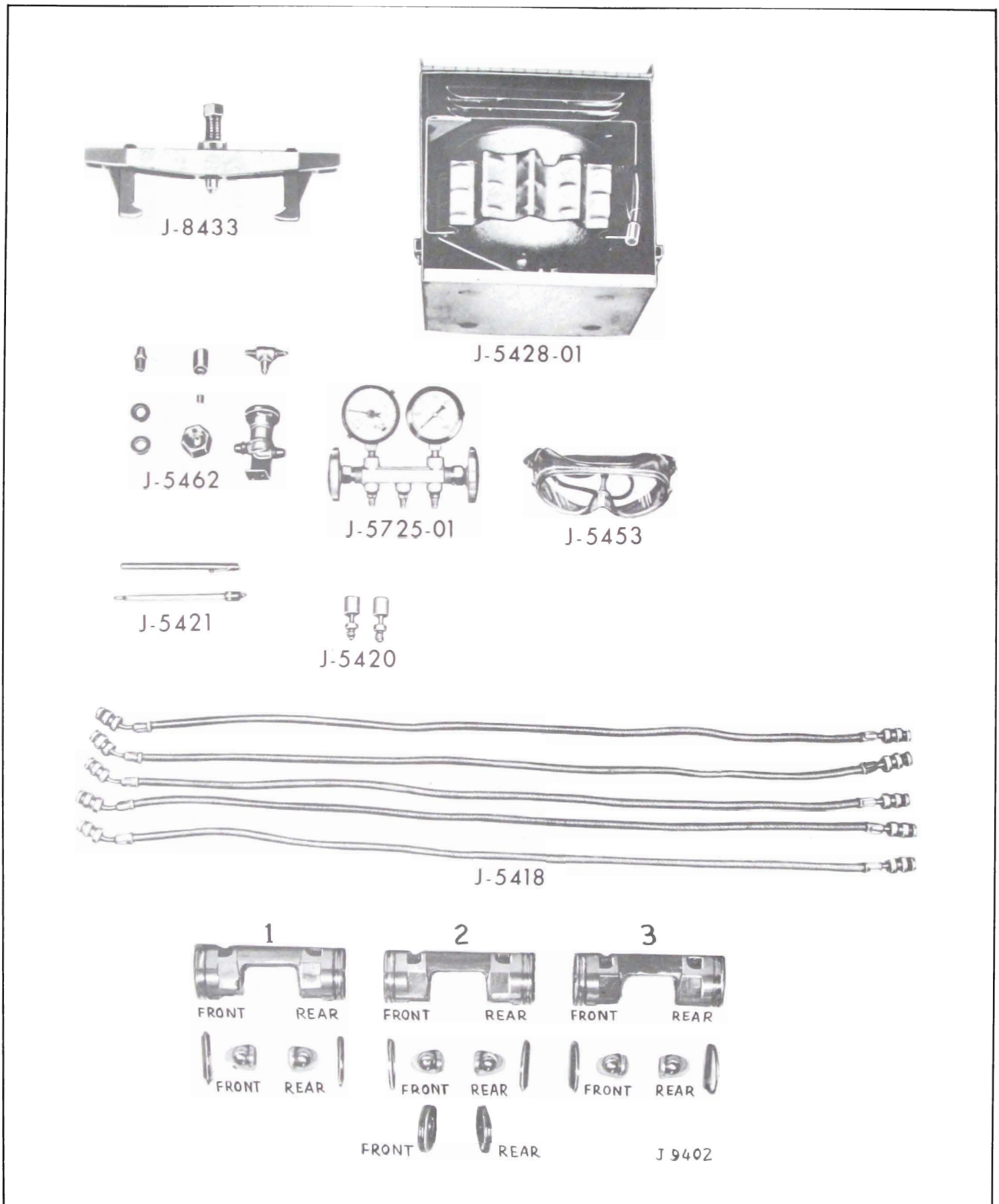

Figure 11-161—Air Conditioner Tools