

## SECTION 8-D

## TILT WHEEL MAST JACKET ASSEMBLY

## CONTENTS OF SECTION 8-D

Paragraph	Subject	Page	Paragraph	Subject	Page
8-23	Description of Tilt Steering Wheel . .	8-50	8-25	Tilt Steering Wheel Service Procedures . . . . .	8-51
8-24	Removal and Installation of Mast Jacket Assembly . . . . .	8-50			

### 8-23 DESCRIPTION OF THE TILT STEERING WHEEL

The optional tilt steering wheel is designed to give ease of entry and driver comfort through seven different steering wheel angle positions. The steering wheel is locked in the selected position by a lever located to the left of the steering column. See Figure 8-79. This lever is pulled toward the steering wheel to disengage the lock and allow positioning the wheel at the desired angle.

The tilt steering assembly basically consists of an upper and lower steering shaft assembly with a universal type joint between them. The joint has two nylon spheres with a spring installed inside them to prevent any looseness in the joint. A support assembly is held to the mast jacket by a lock plate. An actuator is positioned over the upper steering shaft and is attached to the support by two pivot pins. The upper and lower lock shoes, which are retained to the actuator assembly, engage pins in the support. Two springs are attached between the upper edge of the support and actuator and provide for the spring return of the steering wheel to the upward position.

The upper shaft is secured in the actuator assembly by an upper and lower bearing. The bearings are preloaded by means of a 12-sided nut on the steering shaft. When the lever is released, the lock shoes will engage the pins

in the support and hold assembly at angle desired.

When the tilt wheel release lever is moved upward the shoe release actuator causes the lock shoes to move inward and disengage the support. This allows the upper shaft which steering wheel is attached to and the actuator assembly to be set at a different position.

If no pressure is applied to the steering wheel when lever releases lock shoes, the tilt springs will position the steering wheel in its upper most position. Each position moves the steering wheel five degrees.

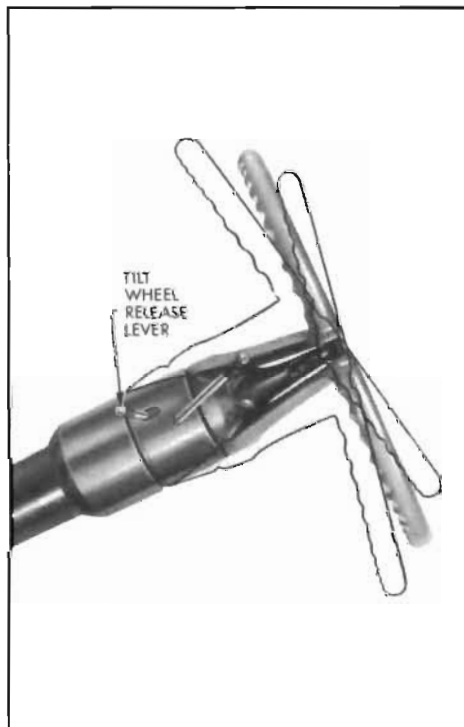

Figure 8-79—Tilt Steering Wheel Release Lever

### 8-24 REMOVAL AND INSTALLATION OF MAST JACKET ASSEMBLY

#### a. Removal

1. Disconnect ground strap from battery.
2. Disconnect shift rod from lower shift lever (automatic transmission only).
3. Remove steering shaft lower coupling pinch bolt.
4. Remove all connectors from mast jacket switches.
5. Remove nut from clamp that retains jacket to lower edge of instrument panel.
6. Pry off plastic trim cover and remove screws and washers that retain toe pan lower cover in position.
7. Carefully pull mast jacket assembly up and out of opening in toe pan.

**CAUTION:** Use care not to damage shift indicator pointer.

#### b. Installation

1. Position mast jacket assembly through opening in toe pan.
2. Install steering shaft into lower coupling on steering gear shaft so that the flat on the shaft is parallel with pinch bolt.
3. Attach jacket to instrument panel and to toe pan. Install plastic trim cover onto toe pan and

secure in position with plastic fastener pins. Drive pins in position with suitable dowel.

4. Install wiring connectors on switches on jacket.
5. Connect battery ground cable.
6. Check neutral safety switch adjustment and adjust if necessary.

## 8-25 TILT STEERING WHEEL SERVICE PROCEDURES

### a. Disassembly of Actuator, Steering Shaft, and Support

NOTE: The parts of the tilt wheel mechanism may be removed while the mast jacket assembly is installed in the car. If it is necessary to remove shift tube, the jacket assembly must be removed from car.

Reassembly will be facilitated if during disassembly the parts are laid out in the sequence that they are removed.

1. Remove steering wheel (ref. par. 8-5).
2. Remove direction signal switch from mast jacket. Disconnect control cable from switch.

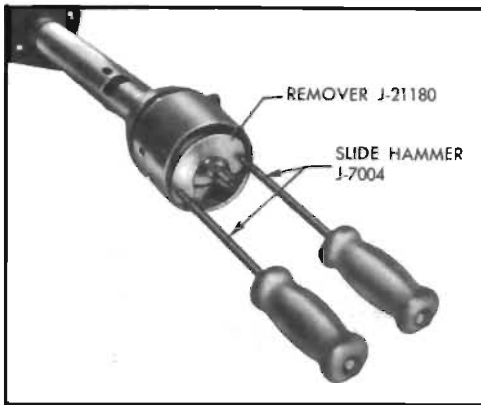

Figure 8-81—Removing Cover from Mast Jacket

3. Remove direction signal lever and tilt wheel release lever.
4. Straighten locking tabs of lock plate (see Figure 8-80) and remove 12-sided nut, lock plate, and inner race seat from upper portion of mast jacket.
5. Assemble two Slide Hammers J-7004 to Remover J-21180 and install inside cover as shown in Figure 8-81. Hold edges of Remover J-21180 against rim of cover and evenly work cover off of mast jacket.
6. Remove turn signal detent spring and carefully pry out actuator yoke.
7. Pry up horn contact ring and plastic bearing cap, and withdraw horn contact ring wire as far as

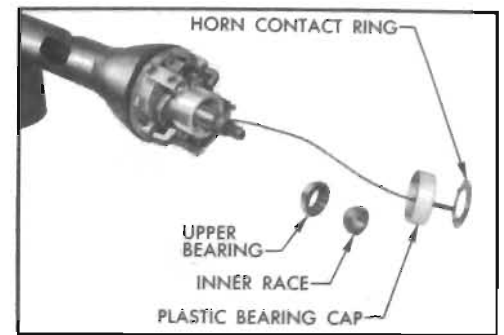

Figure 8-82—Removing Inner Race and Upper Bearing from Upper Portion of Mast Jacket

necessary. Lift off inner race and upper bearing (see Figure 8-82).

8. Reinstall tilt release lever and position actuator assembly at the extreme up position.
9. Unhook upper ends of tilt springs by inserting a screwdriver (or Installer J-21181) in top coil of spring and prying upward, then disengage top loop of spring with another screwdriver. See Figure 8-83. View A shows removing spring on left side and View B shows removing spring on right side.
10. Remove the two pivot pins with Remover J-21179. See Figure 8-84. Thread stud of J-21179 into pin. Hold stud and turn nut to remove pin.

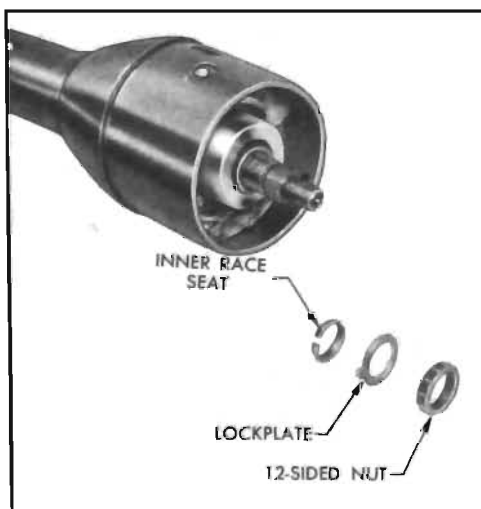

Figure 8-80—Removing 12-Sided Nut, Inner Race and Lockplate

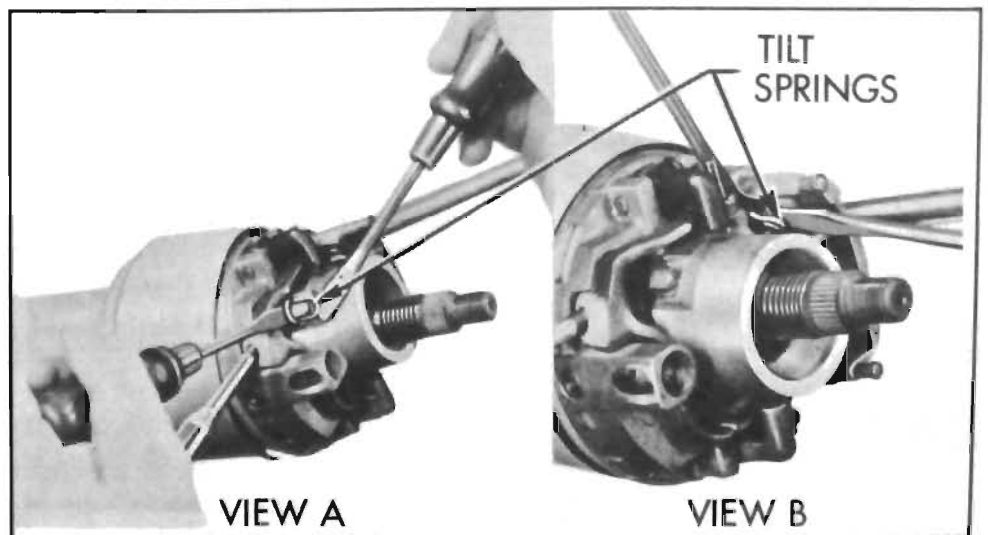

Figure 8-83—Removing Tilt Springs

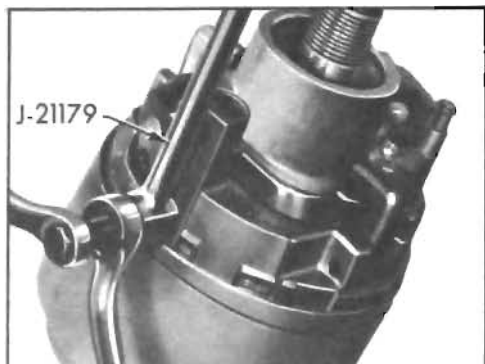

Figure 8-84—Removing Pivot Pin

11. Lift tilt wheel release lever to disengage lock shoes from the support and remove actuator assembly. See Figure 8-85. Remove tilt springs.

12. Remove lower bearing from steering shaft.

13. From the engine compartment remove the pinch bolt from the lower steering shaft coupling.

14. Mark location of clamp on lower portion of steering shaft and remove clamp and spring.

15. Remove steering shaft assembly by pulling it up and out of mast jacket.

16. Remove the four Phillips head support screws and then lift support off jacket.

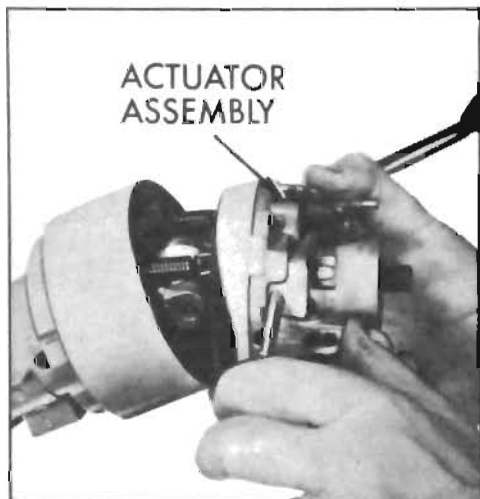

Figure 8-85—Removing Actuator Assembly

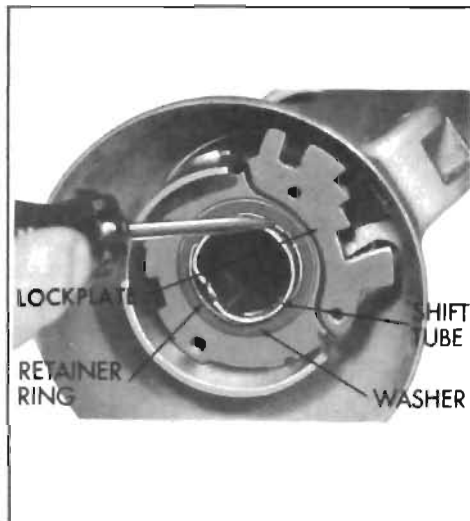

Figure 8-86—Removing Shift Tube Retainer Ring

#### b. Disassembly of Shift Bowl and Shift Tube

1. Remove mast jacket assembly from car. Paragraph 8-24.

2. Remove actuator, steering shaft and support from mast jacket. Refer to subparagraph "a".

3. Remove the shift tube retainer ring and washer from the top of shift tube. See Figure 8-86.

4. Remove steering shaft bearing and adapter from the lower end of the mast jacket.

5. Remove the shift tube and felt seal downward through column by tapping lightly with a mallet on shift lever. See Figure 8-87.

6. Remove lock plate, wave washer and shift bowl from upper end of the mast jacket.

#### c. Reassembly of Shift Bowl and Shift Tube

1. Install shift bowl on the mast jacket, the wave washer lubricated with front wheel bearing lube over the mast jacket, and then slide the lock plate into position through the opening in the mast jacket.

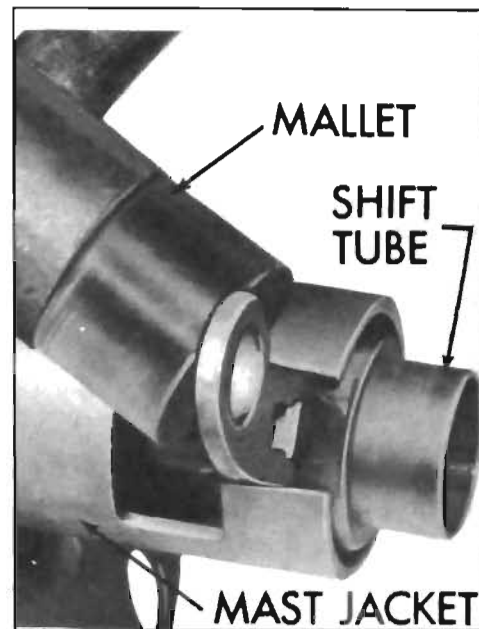

Figure 8-87—Removing Shift Tube

2. Install the shift tube assembly with felt seal into the mast jacket from the lower end of the jacket.

3. Apply lube to thrust washer and install the washer and retaining ring on the upper end of the shift tube.

4. Install lower steering shaft bearing and adapter into lower end of mast jacket.

5. Install support, steering shaft, and actuator assemblies in mast jacket. Refer to subparagraph "f".

6. Install mast jacket in car. Paragraph 8-24, subparagraph "b".

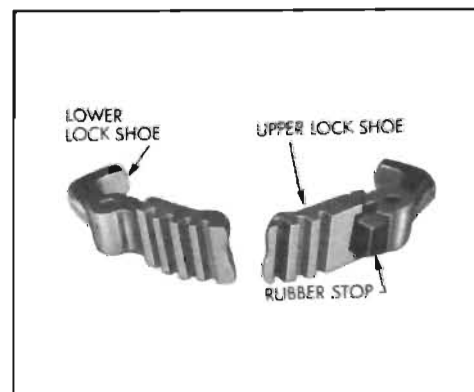

Figure 8-88—Lock Shoes

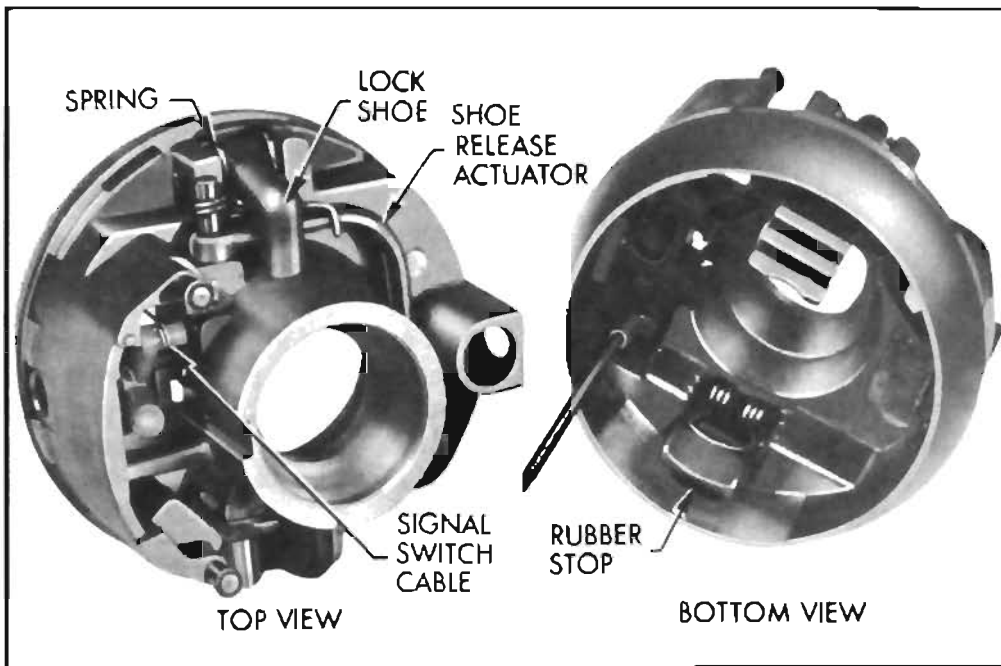

Figure 8-89—Actuator Assembly

#### d. Disassembly and Reassembly of Actuator

##### DISASSEMBLY

**NOTE:** The actuator, lock shoes and springs may be replaced separately. The shoe release actuator is serviced only with the actuator. See subparagraph "a" for removal of actuator.

1. Drive lock shoe pins out of actuator and remove shoes and springs. The upper shoe has a rubber stop on it. See Figure 8-88.

2. If necessary remove control cable from actuator.

##### REASSEMBLY

3. If control cable was removed, install the control cable on the bell crank in actuator and mount cable loop inboard. Install cable bracket screw.

4. If lock shoes were removed from actuator, install the springs on the upper end over lock shoes, then install the shoes in the actuator and retain with the pins. See Figure 8-89.

**NOTE:** The upper lock shoe must have the rubber stop installed.

#### e. Disassembly and Reassembly of Steering Shaft Assembly

##### DISASSEMBLY

**NOTE:** See subparagraph "a" for removal of shaft assembly.

1. Turn upper shaft slightly from centerline of lower shaft.

2. Using a narrow bladed screwdriver, compress joint preload spring enough to remove from upper shaft, then remove spring from centering spheres. See Figure 8-90.

3. Turn upper shaft 90° from centerline of lower shaft and remove shaft over flats of centering sphere.

4. Remove the sphere from the upper shaft by rotating so sphere flats align with shaft socket.

##### REASSEMBLY

5. Apply front wheel bearing lube to the centering spheres and the steering shaft sockets.

6. Place the centering spheres in the upper shaft socket.

7. Turn the spheres so the lower

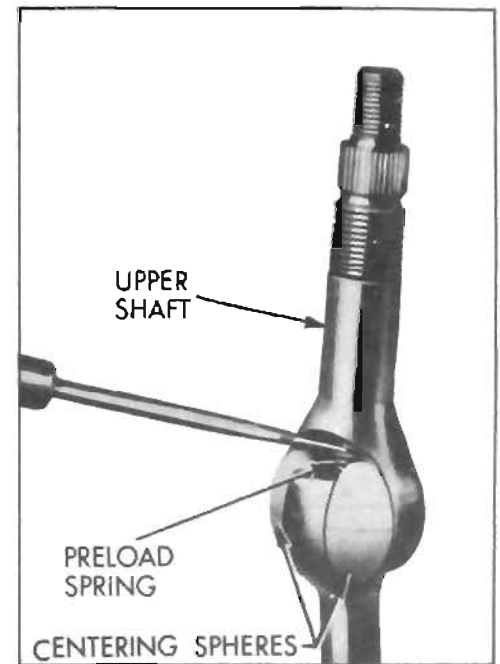

Figure 8-90—Removing Joint Preload Spring

shaft can be installed over the flat area of the spheres. (Approximately 90° from centerline of lower shaft.) Then install lower shaft socket over the sphere so that locating mark on end of upper shaft is on same side as flat on lower shaft.

8. Insert the joint preload spring through centering spheres into lower shaft. Using the upper shaft to hold the spring in place and a screwdriver in the other hand, carefully feed spring into shaft joint. See Figure 8-91.

#### f. Reassembly of Support, Steering Shaft, and Actuator

When assembling parts, apply a thin coat of front wheel bearing lube to all friction parts.

1. Install the support on the upper end of the mast jacket and install the four attaching support screws. Torque screws to 25 in. lb. Torque larger screws first.

2. Install the steering shaft into the mast jacket.

3. Place the lower bearing on upper portion of steering shaft.

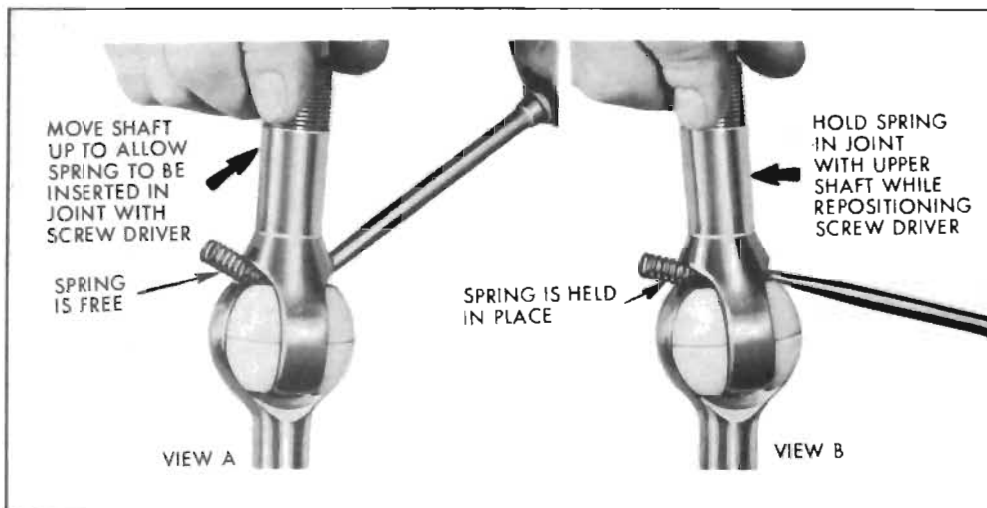

Figure 8-91—Installing Preload Spring

4. Snap the lower ends of the two tilt springs on the support spring anchor.

5. Install the tilt lever into the lock shoe release actuator.

6. Apply front wheel bearing lube on lock shoes and on frictional surfaces at actuator assembly including surfaces where actuate contacts support. Move the tilt lever up slightly to prevent the lock shoes from engaging the support pins, then install the actuator assembly over the steering shaft and feed horn contact ring wire

and direction signal switch control cable thru shift bowl. Position actuator assembly on support.

**NOTE:** Reassembly will be facilitated during seating of actuator in support if the mast jacket is supported in a vise and the steering shaft is slightly moved up.

7. Apply lube to pivot pins. Align the actuator assembly pivot pin holes with the holes in the support assembly and install pivot pins. Pins should be flush with edge of actuator.

8. Raise tilt release lever and position actuator at extreme up position.

9. Connect the upper ends of the tube tilt springs using Installer J-21181 (see Figure 8-92) to lobes on actuator.

10. Install the turn signal actuator yoke and detent spring. Be sure yoke engages turn signal cable operating lever in actuator.

11. Install upper bearing, inner race, plastic bearing cap and horn

contact ring in original positions. Replace cover by driving into position using a rubber mallet.

12. Install inner race seat, lock plate and 12-sided nut.

13. Tighten 12-sided nut moderately tight. Place steering wheel on steering shaft and use Steering Gear Tension Scale J-544 on outer edge of steering wheel to measure pull required to turn steering shaft. Pull required should not exceed 35-40 inch ounces. Retighten 12-sided nut as necessary.

14. Coat horn contact ring with lubriplate.

15. Install the tilt release and direction signal turn levers in actuator.

16. Install steering wheel. Paragraph 8-5.

17. Install direction signal switch as follows:

a. Position tilt wheel in full down position. Locate switch pin in center position.

b. Place direction signal lever in off position, then install control wire loop over switch operating pin.

c. Attach cable wire clamp to switch.

d. Assemble switch to mast jacket and position switch bracket as far forward (spring extended) as possible and secure to mast jacket.

18. Install spring and clamp onto lower end of steering shaft and compress spring to approximately 1/2 inch dimension.

19. Install lower coupling pinch bolt and tighten to 25 ft. lbs.

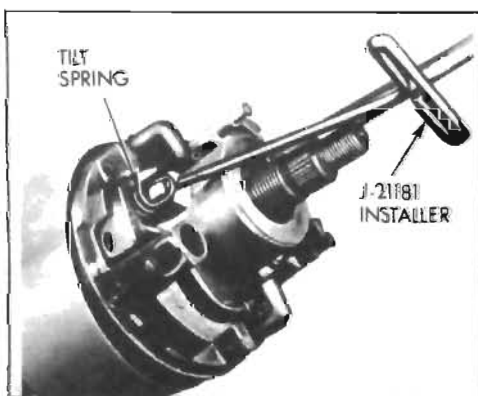

Figure 8-92—Installing Tilt Springs

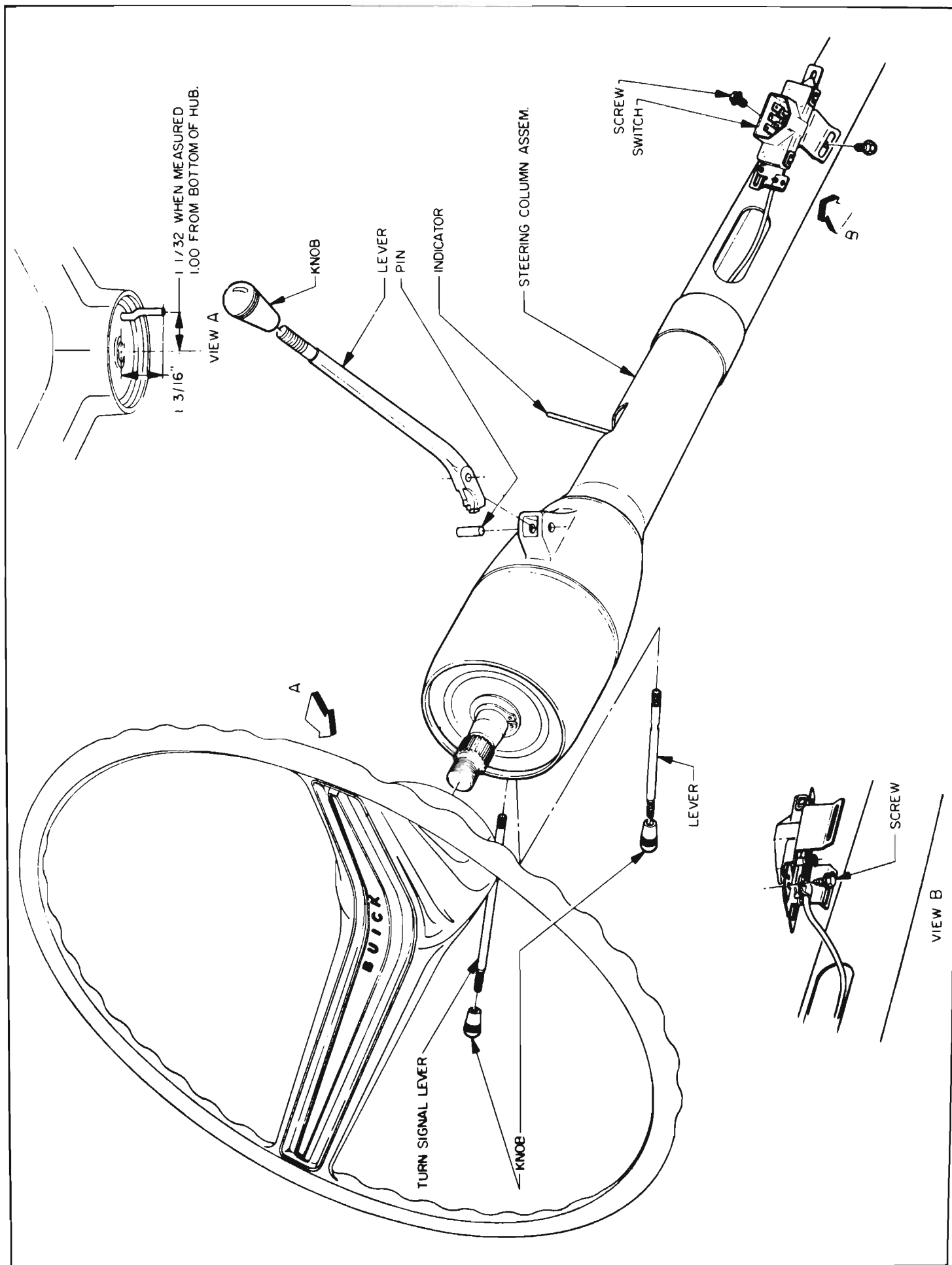

Figure 8-93—Tilt Steering Wheel Installation