

GROUP 5 SUPER TURBINE "300" AUTOMATIC TRANSMISSION

SECTIONS IN GROUP 5

Section	Subject	Page	Section	Subject	Page
5-A	Automatic Transmission Specifications, Description and Operation	5-1	5-B	Hydraulic Controls	5-17
			5-C	Automatic Transmission Adjustment on Car	5-32

SECTION 5-A

43000-44000-45000 SUPER TURBINE "300" AUTOMATIC TRANSMISSION SPECIFICATIONS DESCRIPTION AND OPERATION

NOTE: All references to V-6 transmission does not apply to 45000 Series cars.

CONTENTS OF SECTION 5-A

Paragraph	Subject	Page	Paragraph	Subject	Page
5-1	Automatic Transmission General Specifications	5-1	5-3	Description of Super Turbine "300" Automatic Transmission	5-2
5-2	Automatic Transmission Tightening Specifications	5-2	5-4	Mechanical Operation of Super Turbine 300" Automatic Transmission	5-12

5-1 AUTOMATIC TRANSMISSION GENERAL SPECIFICATIONS

a. Model Designation

Trans. Model	Converter Assembly Information	Valve Body Plate	Reverse Clutch Pressure Plate	Reverse Clutch Piston	Reverse Clutch		Forward Clutch		Forward Clutch Piston	Modulator Can Assembly	Model Usage
					Driven Plate Req'd.	Drive Plate Req'd.	Driven Plate Req'd.	Drive Plate Req'd.			
MJ	Blue Dot of Paint	No Notch	S e e F i g u r e	1366133	5	5	6	5	1357081	8623364 8623365 8623947	All 300 Cu. In. V-8 Models except Sport-wagons
MR	Blue Dot of Paint	No Notch		1366133	5	5	6	5	1357081	8623364 8623365 8623947	All 300 Cu. In. V-8 Model Sportwagons
LS	Orange Dot of Paint	Notch in Valve Body Plate		5-295	1366132	4	4	5	4	1357082	1367031 1367032

b. Transmission Identification Number

A production model number, trans model and model year is stamped on a metal tag, (see Figure 5-1B) or on the low servo cover located on the middle right side of the transmission case. (See Figure 5-1A)

The production code number is located in a circle on the low servo cover see Figure 5-1A. Since the production identification number furnishes the key to construction and interchangeability of parts in each transmission, the number should be used when selecting replacement parts as listed in the master parts list. The number should always be furnished on product reports, AFA forms, and all correspondence with the factory concerning a particular transmission.

c. General Specifications

Oil Capacity	19 Pints
Oil Capacity indicated between Marks on Gauge Rod	1 Pint
Oil Specification	Automatic Transmission Fluid Type A, Suffix A
Planetary Gearing Type	Compound
Number of Pinions	3 Short 3 Long
Drain and Refill Mileage Recommendations. Drain pan replace the Filter on MJ and MR Models and Clean Screen on LJ Models	24,000 Mi.
NOTE: <u>Under extreme heavy operation the above should be performed at</u>	12,000 Mi.
<u>If a major overhaul is necessary the strainer or the filter must be replaced.</u>	
Adjust Low Band	24,000 Mi.
Under Heavy Operation	12,000 Mi.

5-2 AUTOMATIC TRANSMISSION TIGHTENING SPECIFICATIONS

Use a reliable torque wrench to tighten the attaching bolts or nuts of the parts listed below.

NOTE: These specifications are for clean and lubricated threads only. Dry or dirty threads produce increased friction which prevents accurate measurement of tightness.

Part	Location	Thread Size	Torque Ft.-Lbs.
Bolt	Case to Cylinder Block	3/8 -16	30-40
Screw-Tapping	Converter Cover Pan to Transmission Case	1/4 -20	8-12
Pipe Fitting	Water Cooler Pipes to Transmission Case	1/4 -18	25-35
Nut	Nut for Low Band Adjusting Screw	7/16-20	20-30
Bolt	Pump Body to Pump Cover	5/16-18	16-24
Bolt	Stator Control Valve Body to Transmission Case	5/16-18	8-12
Bolt	Valve Body Assembly to Transmission Case	5/16-18	8-12
Bolt	Solenoid Valve to Valve Body	1/4 -20	8-12
Bolt	Vacuum Modulator to Transmission Case	5/16-18	8-12
Bolt	Pump Assembly to Transmission Case	5/16-18	16-24
Bolt	Rear Bearing Retainer to Transmission Case	3/8 -16	25-35
Bolt-Special	Oil Pan to Transmission Case	5/16-18	8-12
Bolt	Speedo Sleeve Retainer to Bearing Retainer	5/16-18	5-10
Bolt	Governor Cover to Transmission Case	5/16-18	8-12

5-3 DESCRIPTION OF SUPER TURBINE "300" AUTOMATIC TRANSMISSION

The Super Turbine "300" automatic transmission is a combination torque converter, two speed planetary geared transmission. Torque multiplication is obtained hydraulically through the converter, and mechanically through a compound planetary gear set. The gear set, in combination with the torque converter, provides a high starting ratio for acceleration from a stop, up steep grades, etc. The torque converter provides torque multiplication for performance and exceptionally

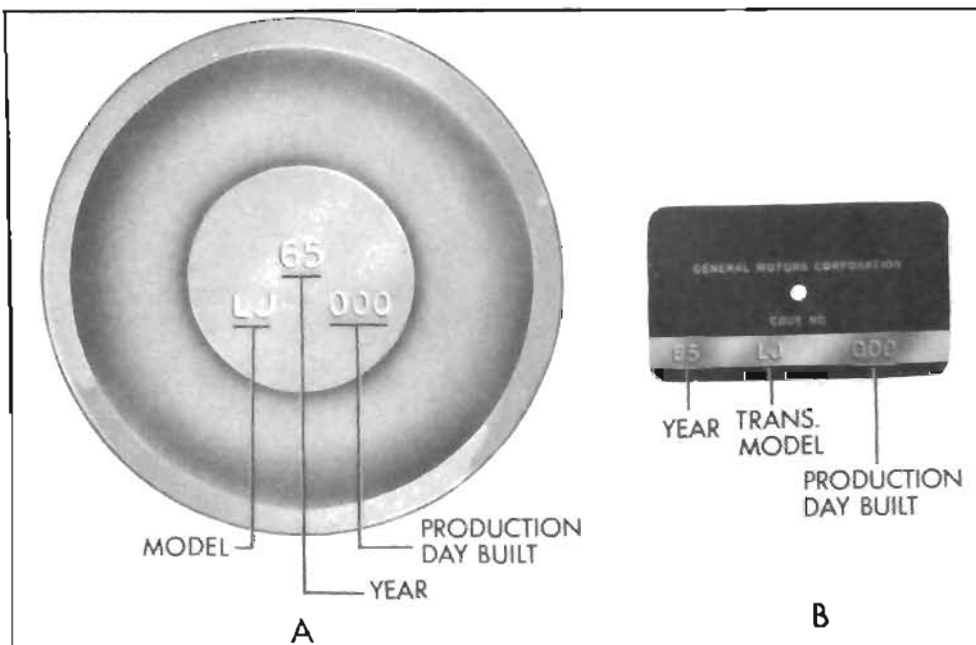

Figure 5-1—Transmission Model Identification



Figure 5-2—Converter Pump



Figure 5-3—Stator and Stator Shaft

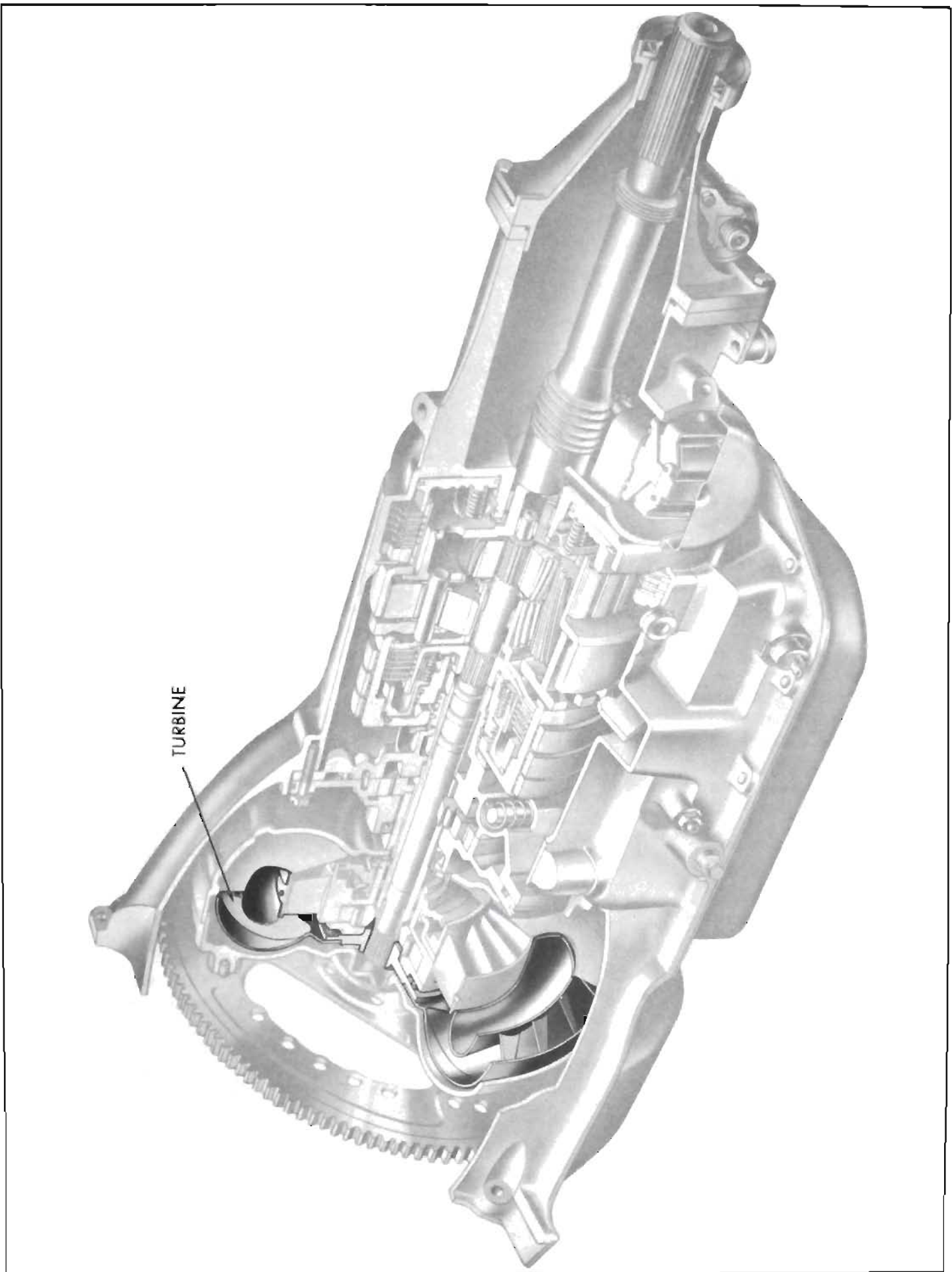

Figure 5-4—Converter Turbine

smooth operation. It functions as a fluid coupling at normal road load conditions and at higher speeds. Description of transmission is divided into six (6) basic sections: (1) Torque Converter, (2) Oil Pump, (3) Planetary Gear Set and Controls, (4) Reverse Clutch, (5) Governor, (6) Valve Body.

1. Torque Converter

The torque converter is connected to the engine flywheel and serves as a hydraulic coupling through which engine torque is transmitted to the input shaft. The torque converter steps up or multiplies engine torque whenever operating conditions demand greater torque than the engine alone can supply. The torque converter consists of three (3) basic sections: (a) Converter Pump, (b) Variable Pitch Stator, (c) Converter Turbine.

a. Converter Pump

The function of the converter pump is to convert engine torque into an energy transmitting flow of oil to drive the converter turbine into which the oil is projected. The converter pump operates as a centrifugal pump, picking up oil as its center and discharging the oil at its rim. However, the converter is shaped to discharge the oil parallel to its axis in the form of a spinning hollow cylinder. See Figure 5-2.

b. Variable Pitch Stator

The variable pitch stator is located between the converter turbine and the converter pump, and is supported by the stator shaft. The stator is equipped with a free wheel clutch assembly. When the clutch assembly is held stationary, it changes the direction of oil flow from the turbine to the proper angle for smooth entrance into the converter pump. As the turbine approaches pump speed

the direction of oil flow changes until it no longer opposes pump rotation. The stator then free wheels so that it will not interfere with the flow of oil between the turbine and converter pump. For normal operation in Drive range the stator blades are set at low angle. For increased acceleration and performance, torque may be obtained by setting the stator blades at high angle. See Figure 5-3.

c. Converter Turbine

The function of the converter turbine is to absorb energy from the oil projected into it by the pump and convert the energy into torque and transmit that torque to the input shaft. See Figure 5-4.

2. Oil Pump

A positive displacement internal-external gear type oil pump is used to supply oil to fill the converter, for engagement of forward and reverse clutches for application and release of the low band and to circulate oil for lubrication and heat transfer. See Figure 5-5.

3. Planetary Gear Set and Controls

The planetary gear set consists of an input sun gear, low sun gear, short and long pinions, a reverse ring gear and a planet carrier. The input sun gear is splined to the input shaft. The low sun gear, which is part of the forward clutch assembly, may revolve freely until the low band is applied. The input sun gear is in mesh with three (3) long pinions and the long pinions are in mesh with three (3) short pinions. The short pinions are in mesh with the low sun gear and reverse ring gear. The input sun gear and short pinions always rotate in the same direction. Application of either the low band or the reverse

clutch determines whether the output shaft rotates forward or backward. See Figure 5-6.

a. Forward Clutch

The forward clutch assembly consists of a drum, piston, springs, piston seals, and a clutch pack. These parts are retained inside the drum by the low sun gear and flange assembly and retainer ring. When oil pressure is applied to the piston, the clutch plates are pressed together connecting the clutch drum to the input shaft through the clutch hub. This engagement of the clutch causes the low sun gear to rotate with the input shaft. See Figure 5-7.

b. Low Band

The low band is a double-wrap steel band faced with a bonded lining which surrounds the forward clutch drum. The band is hydraulically applied by the low servo piston, and released by spring pressure. See Figure 5-7.

4. Reverse Clutch

The reverse clutch assembly consists of a piston, inner and outer seal, cushion spring, coil springs, clutch pack, and pressure plate. These parts are retained inside the case by a retaining snap ring. When oil pressure is applied to the piston, the clutch plates are pressed together holding the reverse ring gear stationary. This engagement of the clutch causes reverse rotation of the output shaft. See Figure 5-8.

5. Governor

The governor is located to the rear of the transmission case on the left side and is driven off the output shaft. The purpose of the governor is to generate a speed

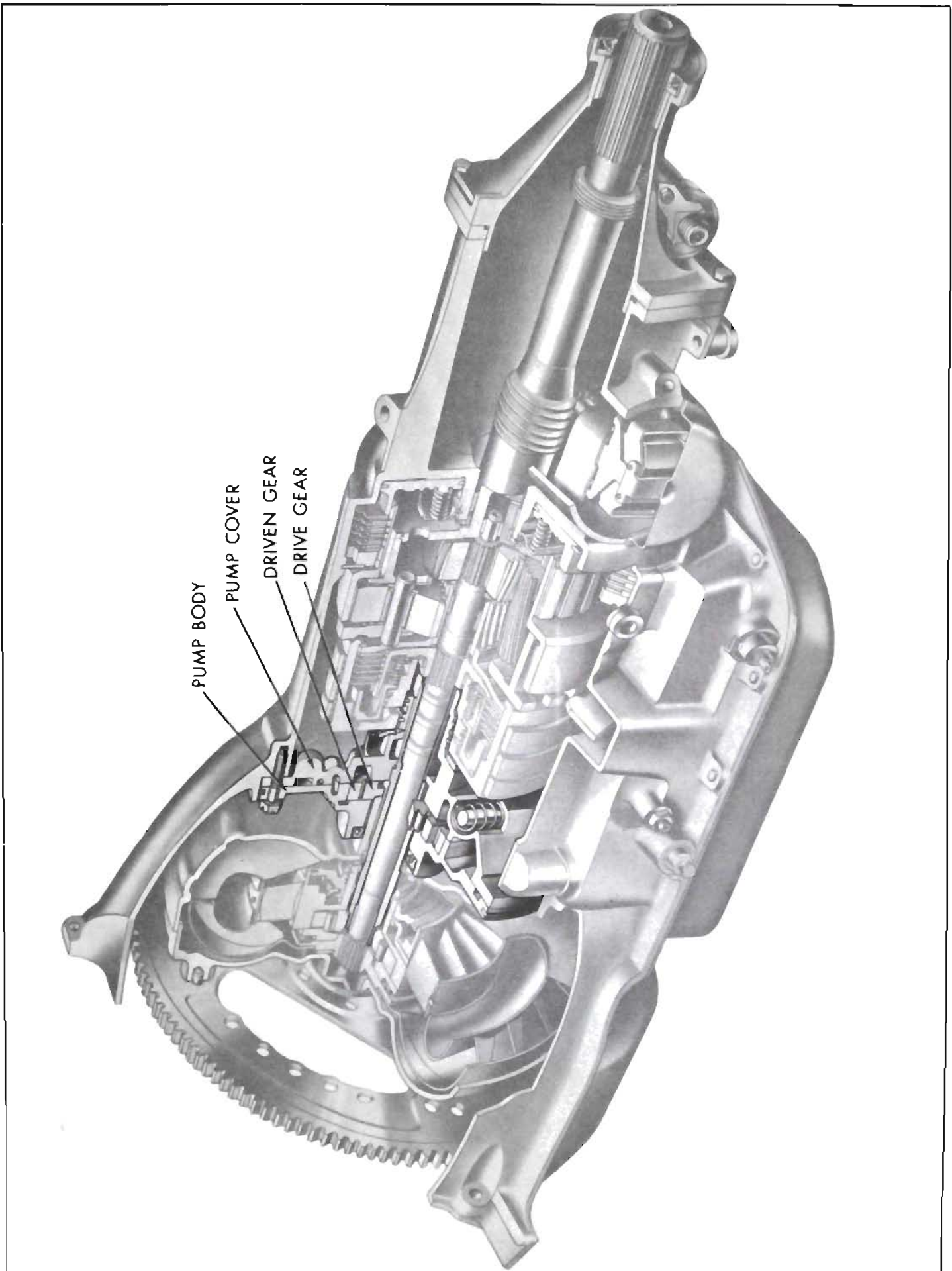

Figure 5-5—Oil Pump and Stator Shaft

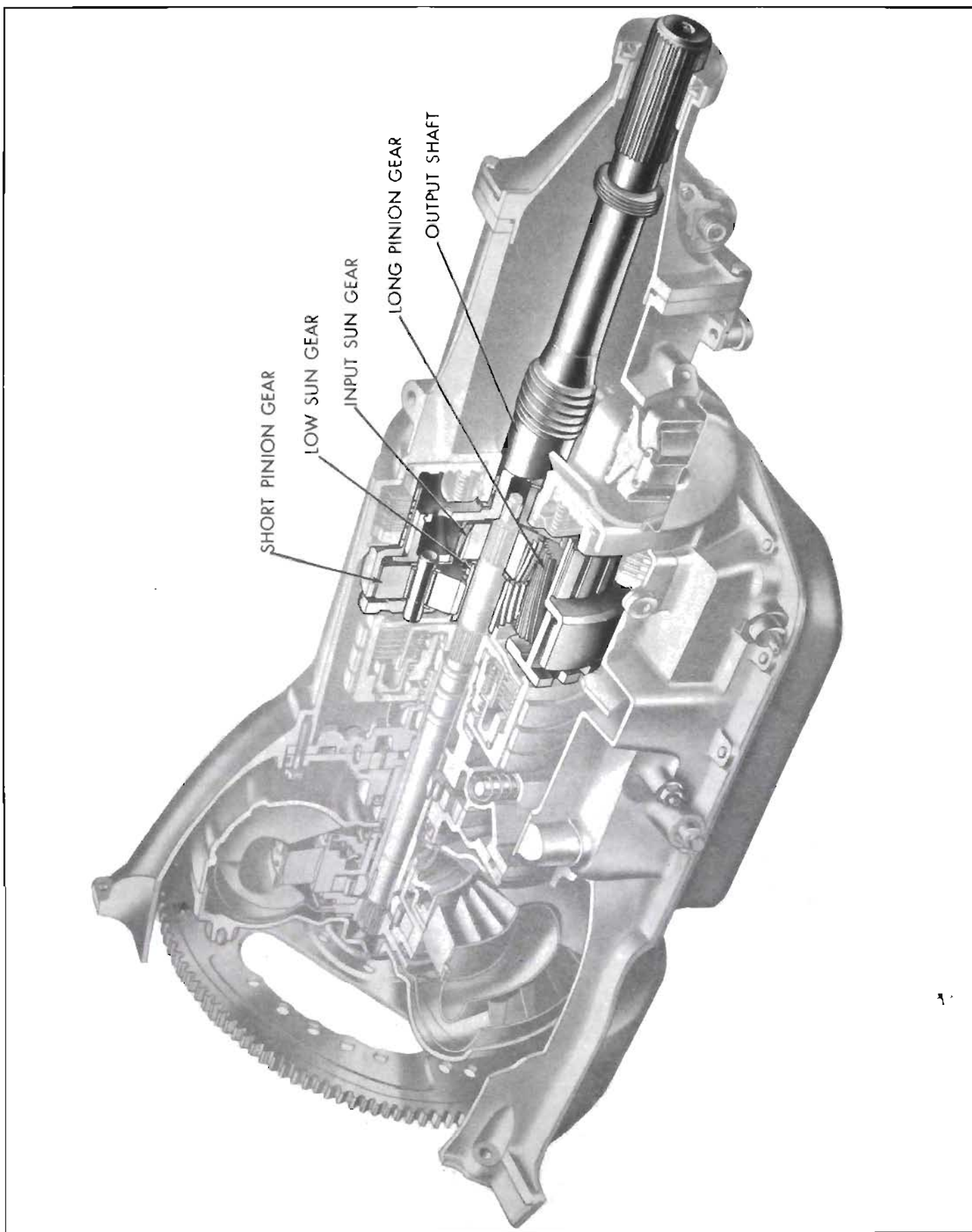

Figure 5-6—Planetary Gear Set

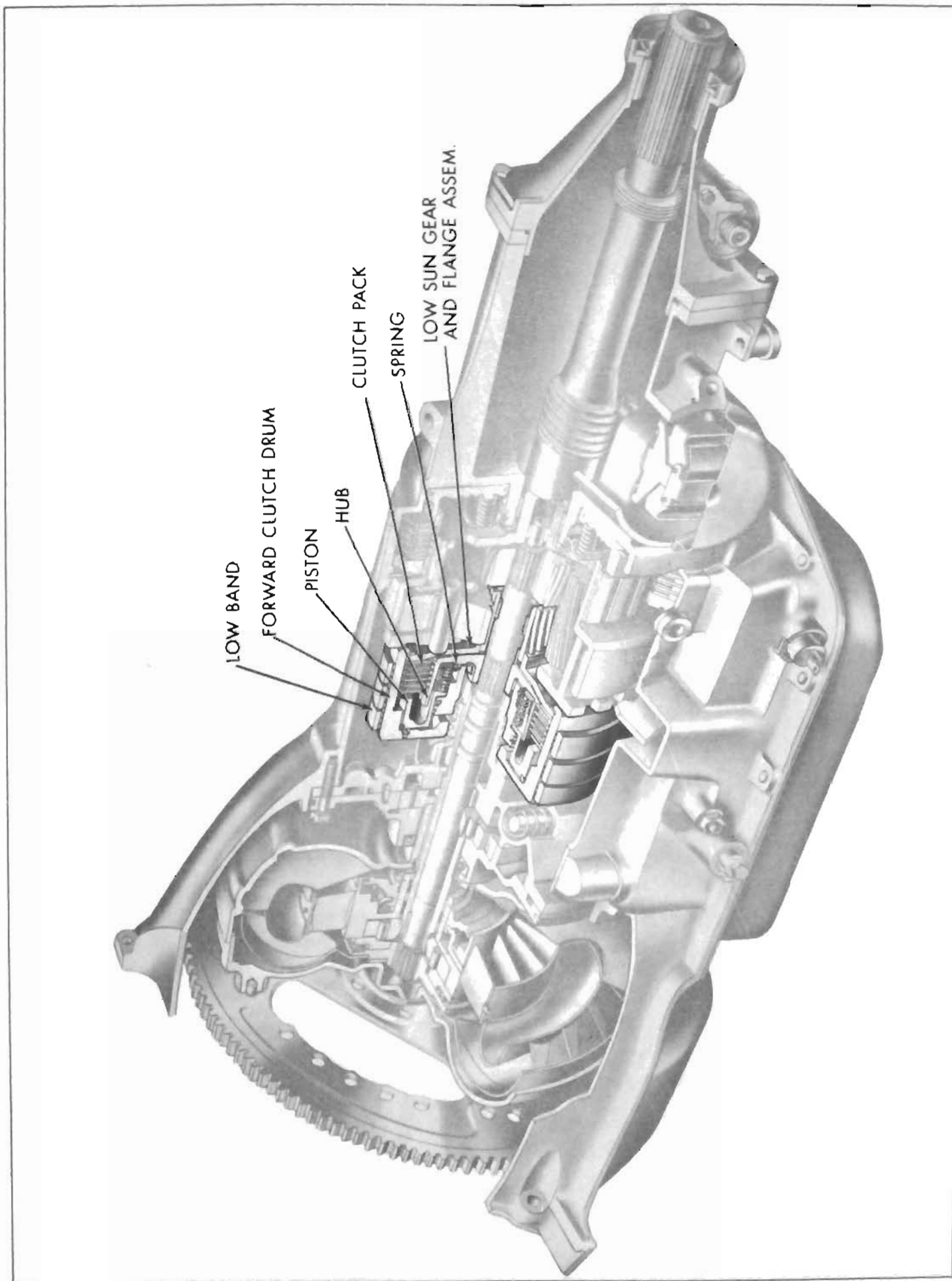

Figure 5-7—Forward Clutch and Low Band

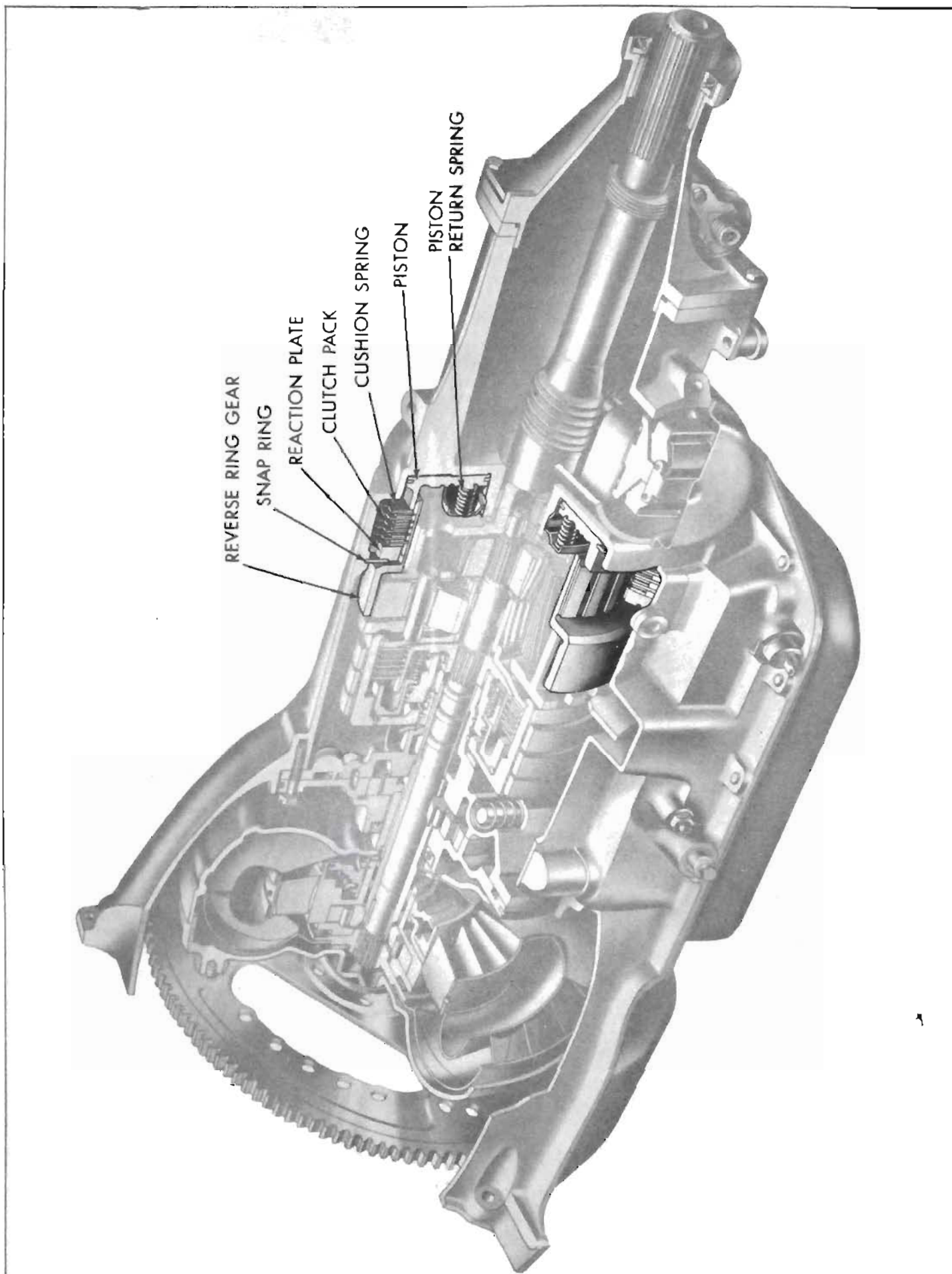

Figure 5-8—Reverse Clutch



Figure 5-9—Cross Section of Transmission

sensitive modulating oil pressure that increases up to a point with output shaft or car speed.

6. Valve Body

The valve body assemblies are bolted to the bottom of the transmission case and are accessible for service by removing the oil pan. The main valve body assembly consists of manual control valve, stator and detent valve, shift valve, modulator limit valve, and high speed downshift timing valve. The stator valve body consists of a stator control valve.

5-4 MECHANICAL OPERATION OF SUPER TURBINE "300" AUTOMATIC TRANSMISSION

1. Operation of Components in Drive Range

With the manual control lever in Drive range, the transmission is started automatically in Low range. The forward clutch is released and the low band is applied to the outside diameter of the forward clutch drum. With the low band applied, the low sun gear and flange assembly are held stationary. Drive then is from the converter through the input shaft to the input sun gear in the planetary gear set. The input sun gear drives the long planet pinions which in turn drive the short planet pinions. The short pinions are in mesh with the low sun gear. With the low sun gear held stationary by the low band application, the short pinions will walk around the low sun gear. As they walk around the sun gear, they carry with them the planet carrier and the output shaft to which they are attached, at a reduction of 1.76 to 1.

The upshift into Drive range is dependent upon car speed and throttle opening. When the shift occurs, the low band is released and the forward clutch is applied. Application of the forward clutch locks the planetary system causing it to rotate as a unit. With the clutch applied, the clutch hub which is splined to the input shaft is locked to the low sun gear and flange assembly through the clutch plates. The low sun gear is meshed to the short pinions, the short pinions are meshed with the long pinions, and the long pinions are meshed with the input sun gear; the sun gear is also splined to the input shaft. Since both the low sun gear and input sun gear are now locked to the input shaft, the entire planetary unit will revolve at input shaft speed. See Figure 5-10.

2. Operation of Components in Manual or Automatic Low Range

In Low range, the forward clutch is released and the low band is applied to the outside diameter of the forward clutch drum. With the low band applied, the low sun gear and flange assembly is held stationary. Drive then is from the converter through the input shaft to the input sun gear in the planetary gear set. The input sun gear drives the long planet pinions which are in mesh with the low sun gear. Since the low sun gear is held stationary with the low band applied, the short pinions walk around the low sun gear, and as they walk around the sun gear, they carry with them the planet carrier and the output shaft to which they are attached at a reduction of 1.76 to 1. See Figure 5-11.

3. Operation of Components in Reverse Range

When the manual control lever is in Reverse position, the forward

clutch and low band are released, and the reverse clutch is applied, holding the ring gear stationary. Drive is through the input shaft and input sun gear to the long pinions and then to the short pinions. The short pinions mesh with the reverse ring gear which is held stationary by the reverse clutch. The short pinions walk around the inside of the ring gear in a reverse direction, turning the output shaft to which they are attached at a reduction of 1.76 to 1. See Figure 5-12.

4. Operation of Components in Neutral

With the shift control lever in Neutral position, the output shaft remains stationary. The clutches and low band are released; therefore, there is no reaction member to provide positive drive. All gears are free to spin around their own axis, and no motion is imparted to the planet carrier. See Figure 5-13.

5. Operation of Components in Park

In Park, all reaction members are released as in Neutral. A positive gear train lock is provided when the parking pawl is engaged with the heavy teeth spaced around the front face of the planetary carrier. The linkage is actuated by direct manual action, but the parking pawl is activated by spring action. If the pawl is in line with a tooth of the planet carrier, rather than a space between teeth, the linkage remains in the park position with the spring holding pressure against the pawl. Slight rotation of the planet carrier will immediately seat the pawl and lock the output shaft to the case. See Figure 5-13.

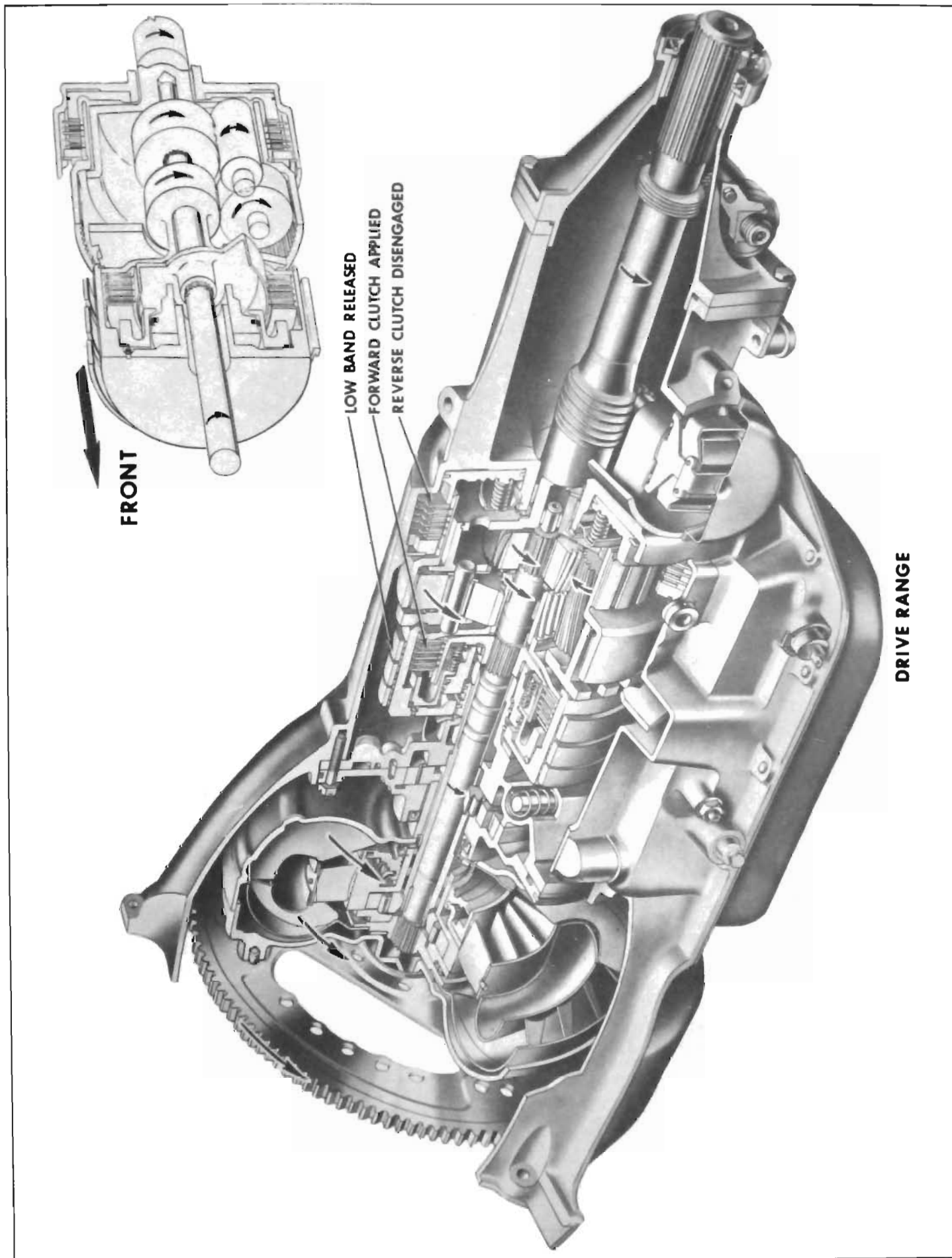

Figure 5-10—Operation of Components in Drive Range

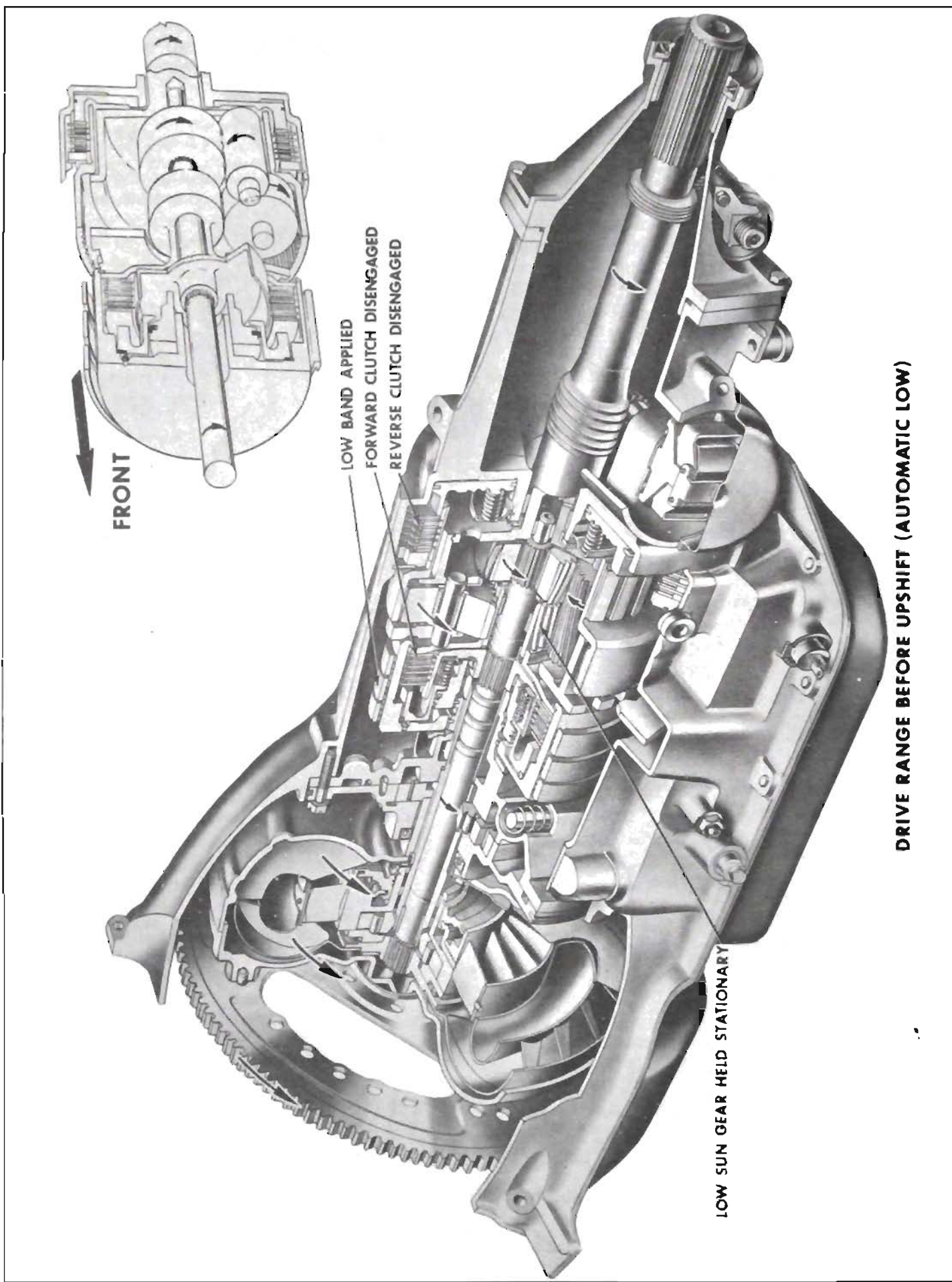

Figure 5-11—Operation of Components in Manual Low or Automatic Low

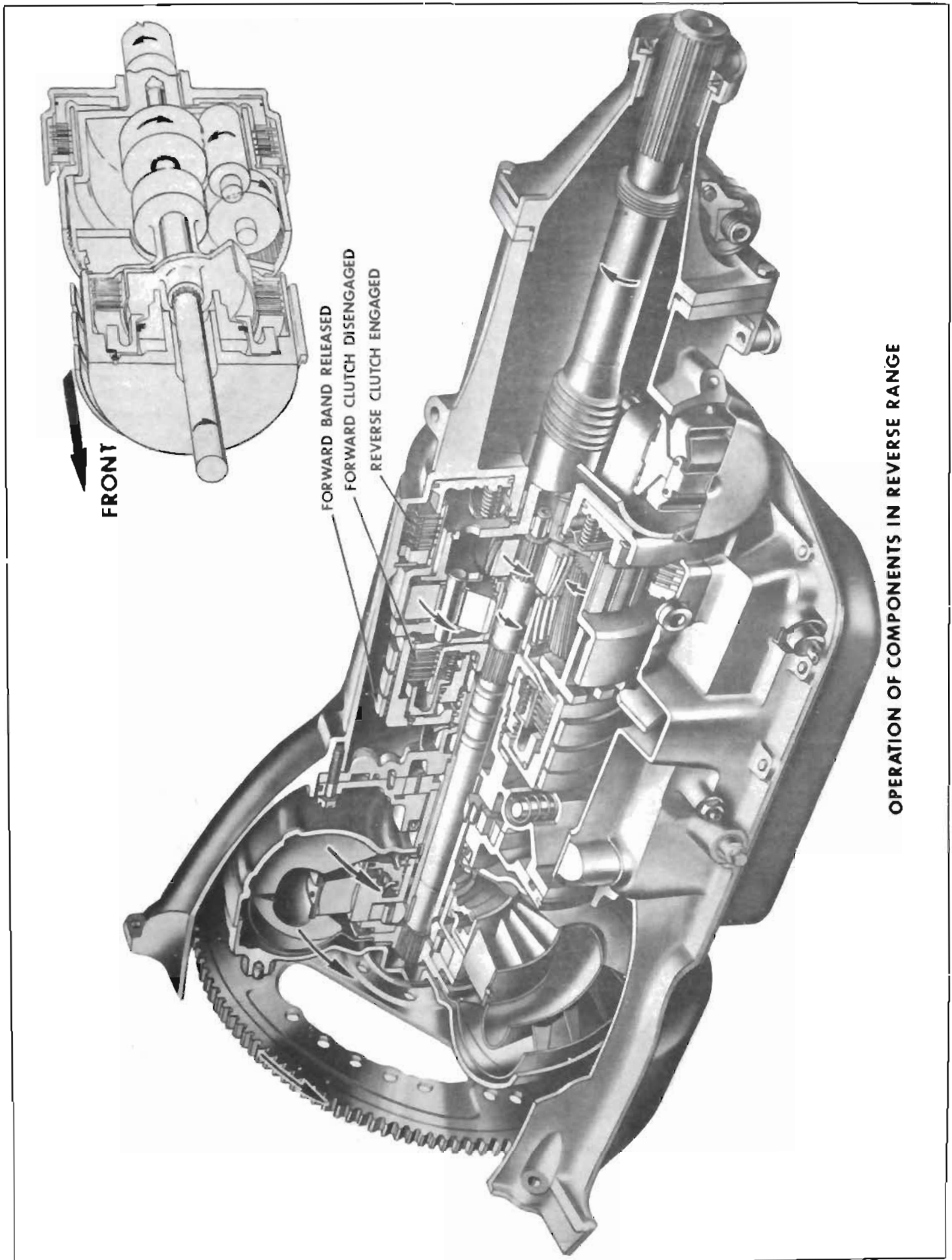

Figure 5-12—Operation of Components in Reverse Range

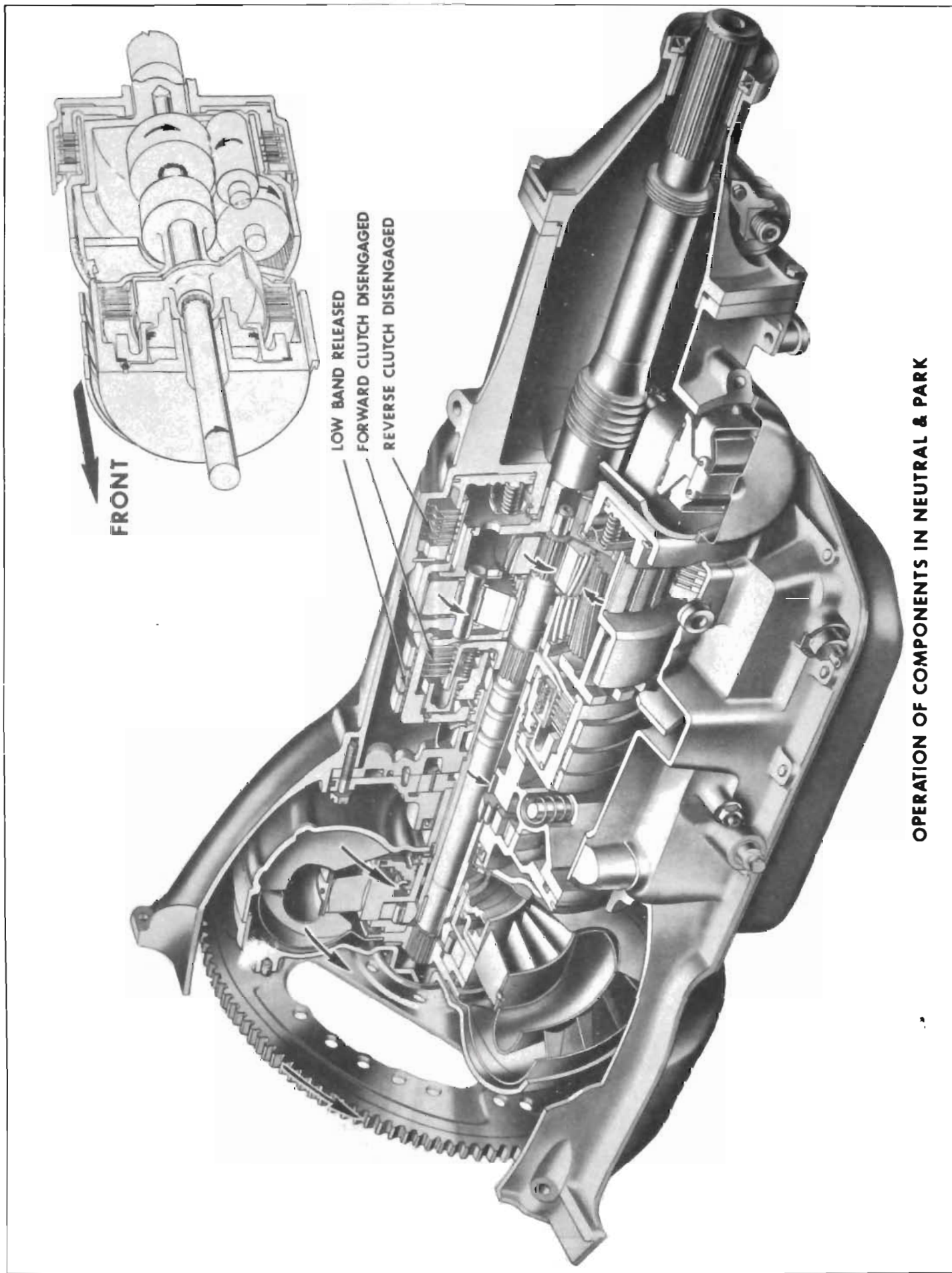

Figure 5-13—Operation of Components in Neutral and Park Range