

SECTION 6-B REAR AXLE SERVICE PROCEDURES

CONTENTS OF SECTION 6-B

Paragraph	Subject	Page	Paragraph	Subject	Page
6-4	Removal and Installation of Rear Axle Assembly	6-6	6-6	Assembly of Rear Axle Assembly	6-9
6-5	Disassembly of Rear Axle Assembly	6-6			

6-4 REMOVAL AND INSTALLATION OF REAR AXLE ASSEMBLY

It is not necessary to remove the rear axle assembly for any normal repairs. However, if the housing is damaged, the rear axle assembly may be removed and installed using the following procedure:

a. Removal of Rear Axle Assembly

1. Raise rear of car high enough to permit working underneath. Place a floor jack under center of axle housing so it just starts to raise rear axle assembly. Place car stands solidly under body members on both sides.
2. Disconnect rear universal joint from pinion flange by removing two U-bolts. Wire propeller shaft to exhaust pipe to support it out of the way.
3. Disconnect parking brake cables by removing adjusting nut at sheave. Remove cable connector and two clips and slide cables back until free of body.
4. Disconnect rear brake hose at floor pan. Cover brake hose and pipe openings to prevent entrance of dirt.
5. Disconnect shock absorbers at axle housing. Lower jack under

axle housing until rear springs can be removed.

6. Disconnect upper control arms at frame brackets.
7. Disconnect lower control arms at axle housing and roll rear axle assembly out from under car.

b. Installation of Rear Axle Assembly

1. Rest car solidly on stands placed under body side members, with rear end of car high enough to permit working underneath. Roll rear axle assembly under car.
2. Connect lower control arms to axle housing.
3. Connect upper control arms at frame brackets.
4. Place rear springs in position and jack axle housing upward until shock absorbers will reach.
5. Connect shock absorbers and tighten nuts to 30-60 ft. lbs. Connect lower control arms and tighten pivot bolts to 20-30 ft. lbs. Connect upper control arm bolts and tighten to 60-85 ft. lbs.
6. Connect parking brake cables. Adjust parking brake according to procedure in paragraph 9-22.
7. Connect rear universal joint to pinion flange. Tighten nuts evenly to 12-15 ft. lbs.

CAUTION: U-bolt nuts must be

torqued as specified, as over-tightening will distort bearings and cause early failure.

8. Connect rear brake hose at floor pan. Bleed both rear brakes and refill master cylinder.
9. Fill rear axle with specified gear lubricant (See par. 1-9). If axle housing or any rear suspension parts were replaced due to damage, rear universal joint angle must be checked and adjusted if necessary. See paragraph 6-16.

6-5 DISASSEMBLY OF REAR AXLE ASSEMBLY

Most rear axle service repairs can be made with the rear axle assembly in the car by raising the rear end of the car with the rear axle hanging on the shock absorbers. See Figure 6-4. Rear axle lubricant may be drained by backing-out all cover bolts and breaking cover loose at the bottom.

a. Remove Axle Shaft Assemblies

Design allows for axle shaft end play up to .042" loose. This end play can be checked with the wheel and brake drum removed by measuring the difference between the end of the housing and the axle shaft flange while moving the axle shaft in and out by hand.

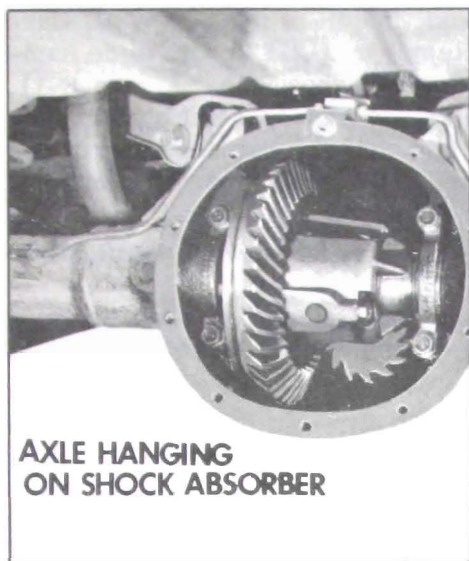

Figure 6-4—Rear Axle Assembly in Position for Repair

End play over .042" is excessive. Compensating for all of the end play by inserting a shim inboard of the bearing in the housing is not recommended since it ignores the the end play of the bearing itself, and may result in improper seating of the gasket or backing plate against the housing. If the end play is excessive, the axle shaft and bearing assembly should be removed and the cause of the excessive end play determined and corrected.

1. Remove wheels. Both right and left wheels have right hand threads.
2. Remove brake drums.
3. Remove nuts holding retainer plates to brake backing plates. Pull retainers clear of bolts, and reinstall two lower nuts finger tight to hold brake backing plate in position.
4. Pull out axle shaft assemblies using Puller J-5748 and Adapter J-2619-4 with a slide hammer. See Figure 6-5.

CAUTION: While pulling axle shaft out through oil seal, support shaft carefully in center of seal to avoid cutting seal lip.

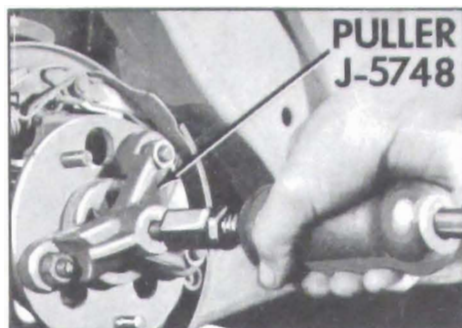

Figure 6-5—Removing Rear Axle Shaft

b. Remove and Install Axle Shaft Bearing

1. Nick bearing retainer in 3 or 4 places with a chisel deep enough to spread ring. Retainer will then slip off. See Figure 6-6.

2. Press axle shaft bearing off using Puller Plate J-8621 with Remover J-6525. An arbor press may be used or a set-up may be made using Ram and Yoke Assembly J-6180 with Adapter J-6258 and Puller J-5748. See Figure 6-7.

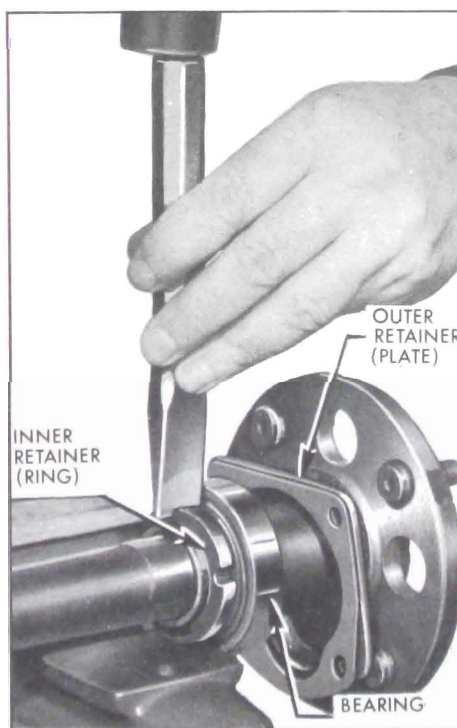

Figure 6-6—Removing Axle Shaft Bearing Retainer

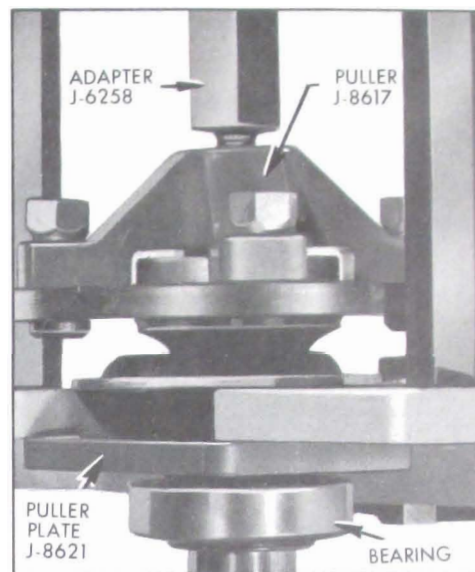

Figure 6-7—Removing Axle Shaft Bearing

3. Press new axle shaft bearing against shoulder on axle shaft using Installer J-8853 with Holder J-6407. See Figure 6-8. **CAUTION:** Retainer plate which retains bearing in housing must be on axle shaft before bearing

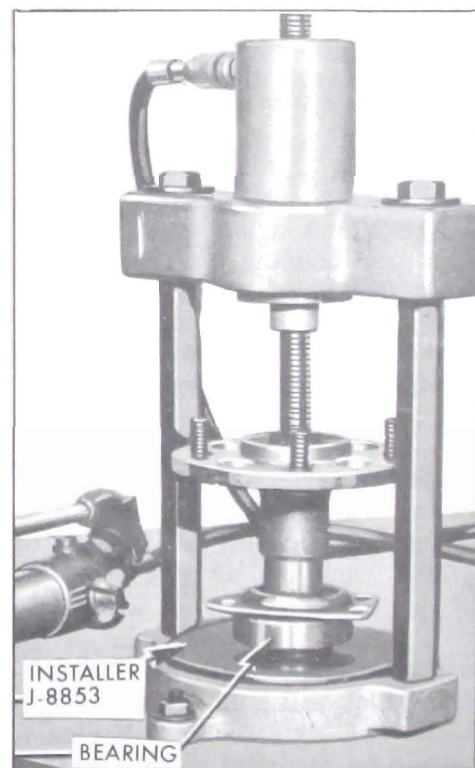

Figure 6-8—Installing Axle Shaft Bearing

is installed; retainer gasket can be installed after bearing.

4. Press new retainer ring against bearing using Installer J-8853.

c. Remove and Install Rear Wheel Bolt

1. To remove and install a rear wheel bolt, axle shaft assembly must be out of car. Remove rear wheel bolt by pressing from axle flange.

2. Install new rear wheel bolt by pressing through axle flange. Check new bolt for looseness; if bolt is loose, axle shaft must be replaced.

d. Remove and Install Axle Shaft Seal

1. Insert axle shaft so that splined end is just through seal.

2. Using axle shaft as a lever, push down on shaft until seal is pried from housing. See Figure 6-9.

3. Apply sealer to O.D. of new seal.

4. Position seal over Installer J-21129 and drive seal straight into axle housing until fully seated. See Figure 6-10.

e. Remove Differential Case Assembly

1. Before removing differential from housing, it is advisable to check the existing ring gear to pinion backlash as described in paragraph 6-6(f). This will indicate gear or bearing wear or an error in backlash or preload setting which will help in determining cause of axle noise. Backlash should be recorded so that if same gears are reused, they may be reinstalled at original lash to avoid changing gear tooth contact.

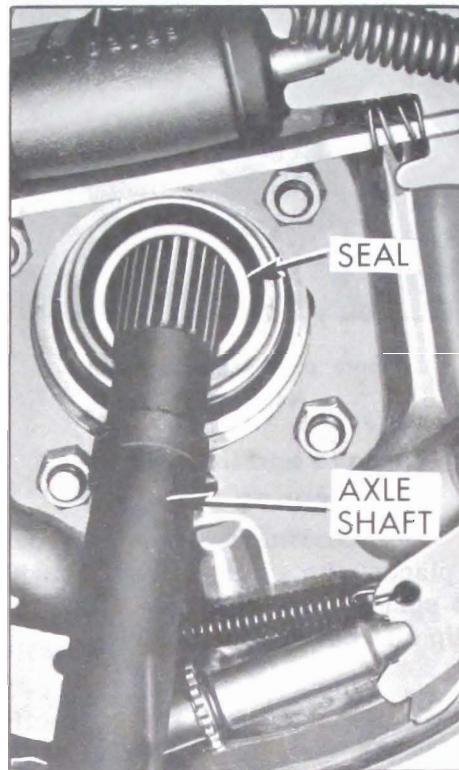

Figure 6-9—Removing Axle Shaft Seal

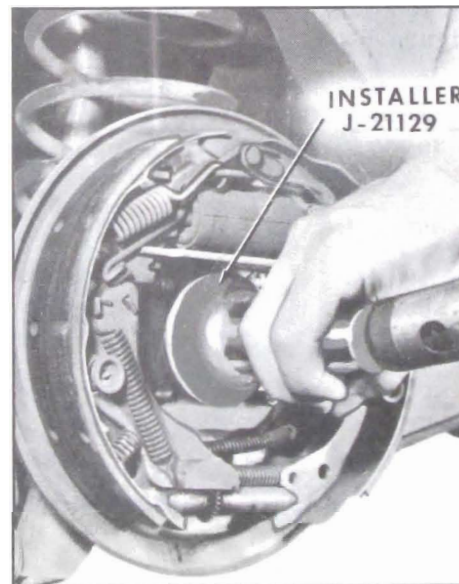

Figure 6-10—Installing Axle Shaft Seal

2. Remove differential bearing cap bolts. Bearing caps are marked "R TOP" and "L TOP" in production to make sure they will be reassembled correctly.

3. Remove two ring gear retaining bolts from differential case

and install Ring Gear & Case Remover J-21322 with slide hammer as shown in Figure 6-11. Remove case assembly and place right and left bearing outer races and shims in sets with marked bearing caps so that they can be reinstalled in their original positions.

f. Disassemble Differential Case Assembly

1. If differential side bearings are to be replaced, insert Remover Adapter J-2241-8 in center hole and pull bearing using Puller J-2241 or Hydraulic Puller J-9005. See Figure 6-12.

2. Remove bolt that retains differential pinion axle. See Figure 6-13. Remove differential pinions, side gears and thrust washers from case.

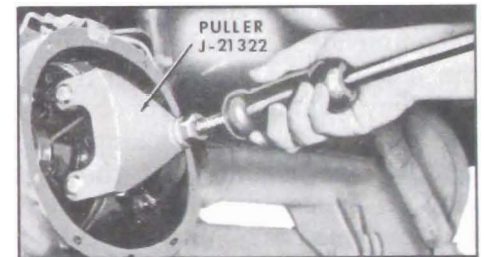

Figure 6-11—Removing Differential Assembly

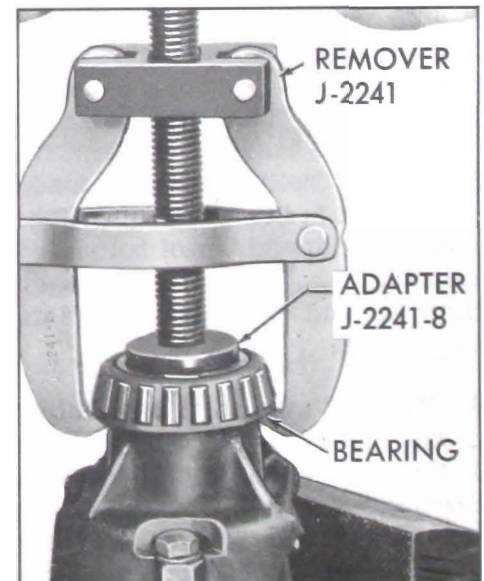

Figure 6-12—Removing Differential Side Bearing

3. If ring gear is to be replaced and it is tight on case after removing bolts, tap it off using a soft hammer; do not pry between ring gear and case.

g. Remove Pinion Assembly

1. Check pinion bearing preload as described in paragraph 6-6(c). If there is no preload reading, check for looseness of pinion assembly by shaking. Looseness indicates need for bearing replacement. If assembly is run long with very loose bearings, ring and pinion will also require replacement.

2. Install holder J-8614-01 on pinion flange by using two 5/16-18 x 2 bolts with flat washers. Remove pinion nut and washer. See Figure 6-14.

3. Pull pinion flange from pinion using Puller J-8614-02 in Holder J-8614-01. To install puller, back out puller screw, insert puller through holder, and rotate 1/8 turn. See Figure 6-15.

4. Remove pinion assembly. If necessary, tap pinion out with soft hammer, while being careful

to guide pinion with hand to avoid damage to bearing outer races.

h. Disassemble Pinion Assembly

1. If rear pinion bearing is to be replaced, remove rear pinion bearing from pinion shaft using Remover J-21493 with Holder J-6407. See Figure 6-16.

2. Pry pinion oil seal from carrier and remove front pinion bearing. If this bearing is to be replaced, drive outer race from carrier using a drift.

3. If rear pinion bearing is to be replaced, drive outer race from carrier using a drift in slots provided for this purpose.

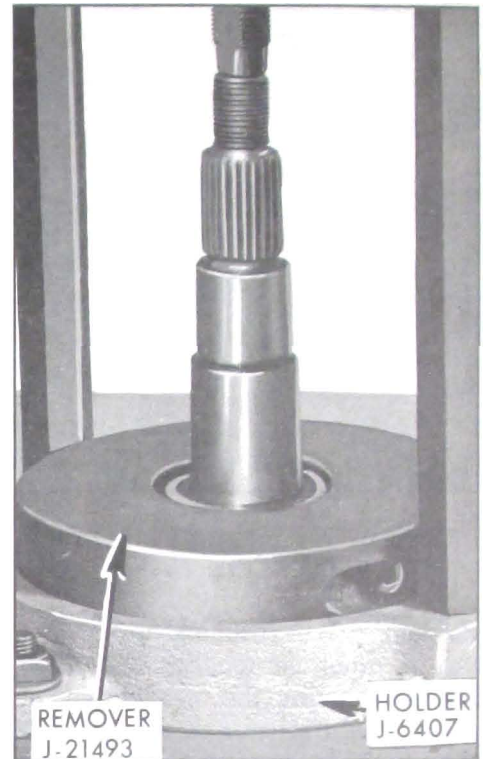

Figure 6-16—Removing Rear Pinion Bearing

6-6 ASSEMBLY OF REAR AXLE ASSEMBLY

a. Install Pinion Bearing Outer Races in Carrier

1. If rear pinion bearing is to be replaced, install new outer race using Installer J-6197 with Driver Handle J-8092. See Figure 6-17.

2. If front pinion bearing is to be replaced, install new outer race using Installer J-7817 with Driver Handle J-8092. See Figure 6-18.

b. Set Pinion Depth

All production pinions are marked to indicate variations in thousandths of an inch over or under "nominal" setting. When a pinion is marked "+" (plus), it means that the pinion, when installed in the carrier, must be at a given distance from the centerline of the pedestals, plus the amount indicated on the pinion in order for it to be positioned at the nominal setting. When a pinion is

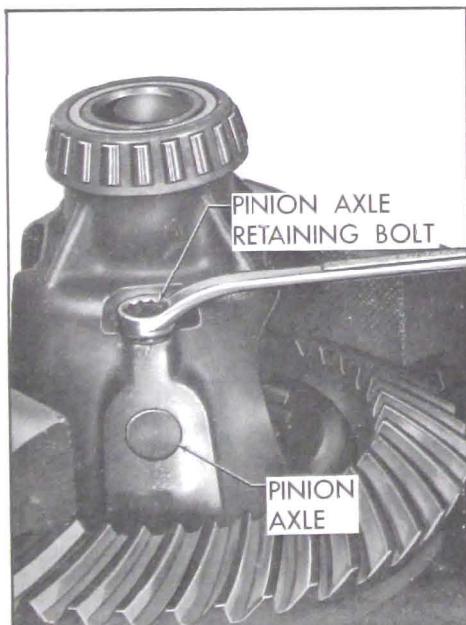

Figure 6-13—Removing Pinion Axle Retaining Bolt

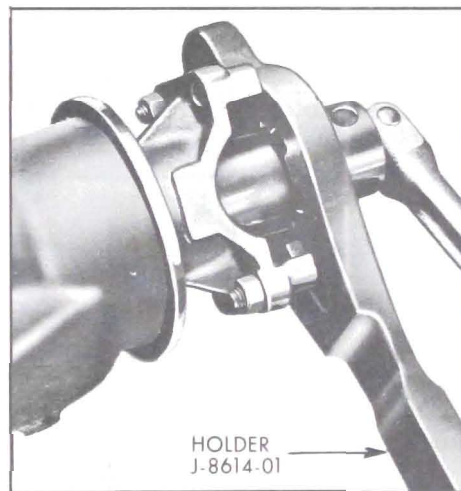

Figure 6-14—Removing Pinion Nut

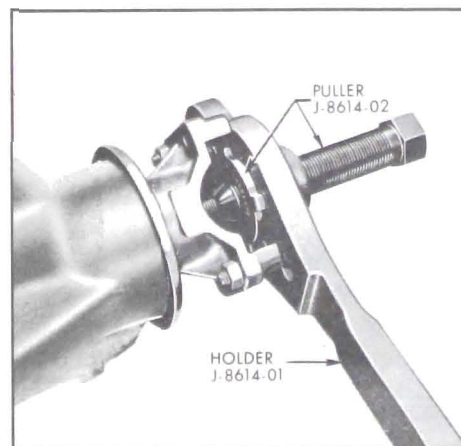

Figure 6-15—Removing Pinion Flange

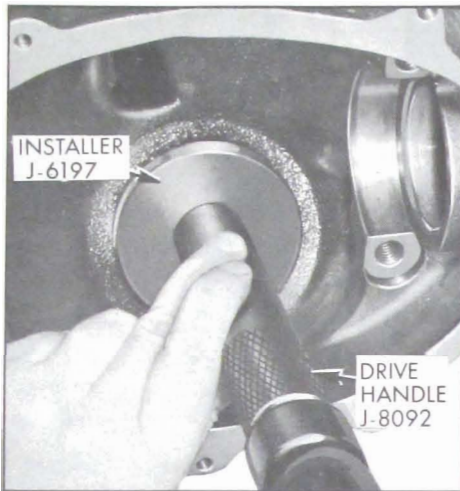

Figure 6-17—Installing Rear Pinion Bearing Outer Race

marked “-” (minus), it means that it must be located at a given distance from the centerline of the pedestals, minus the amount indicated on the pinion in order for it to be located at the nominal setting. All pinions produced for service are nominal or “zero” pinions and are unmarked.

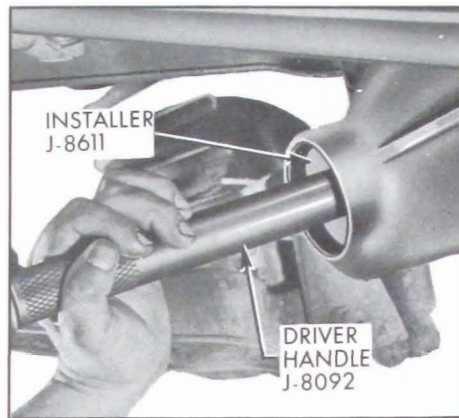

Figure 6-18—Installing Front Pinion Bearing Outer Race

Pinion depth is set with Pinion Setting Gauge J-8619 which consists of the following: (1) master gauge, (1) indicator gauge with dial indicator, (2) J-8619-10 Disks, (1) J-8619-11 Gauge Plate, J-8619-12 Pilot and Nut with J-8619-13 Stud. See Figure 6-19. Although production pinions are marked, neither production nor service pinions have a gauging

tooth. The pinion setting gauge provides in affect a nominal or zero pinion as a gauging reference.

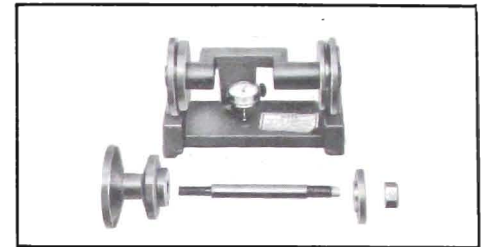

Figure 6-19—Pinion Setting Gauge



Figure 6-20—Zeroing Pinion Setting Gauge

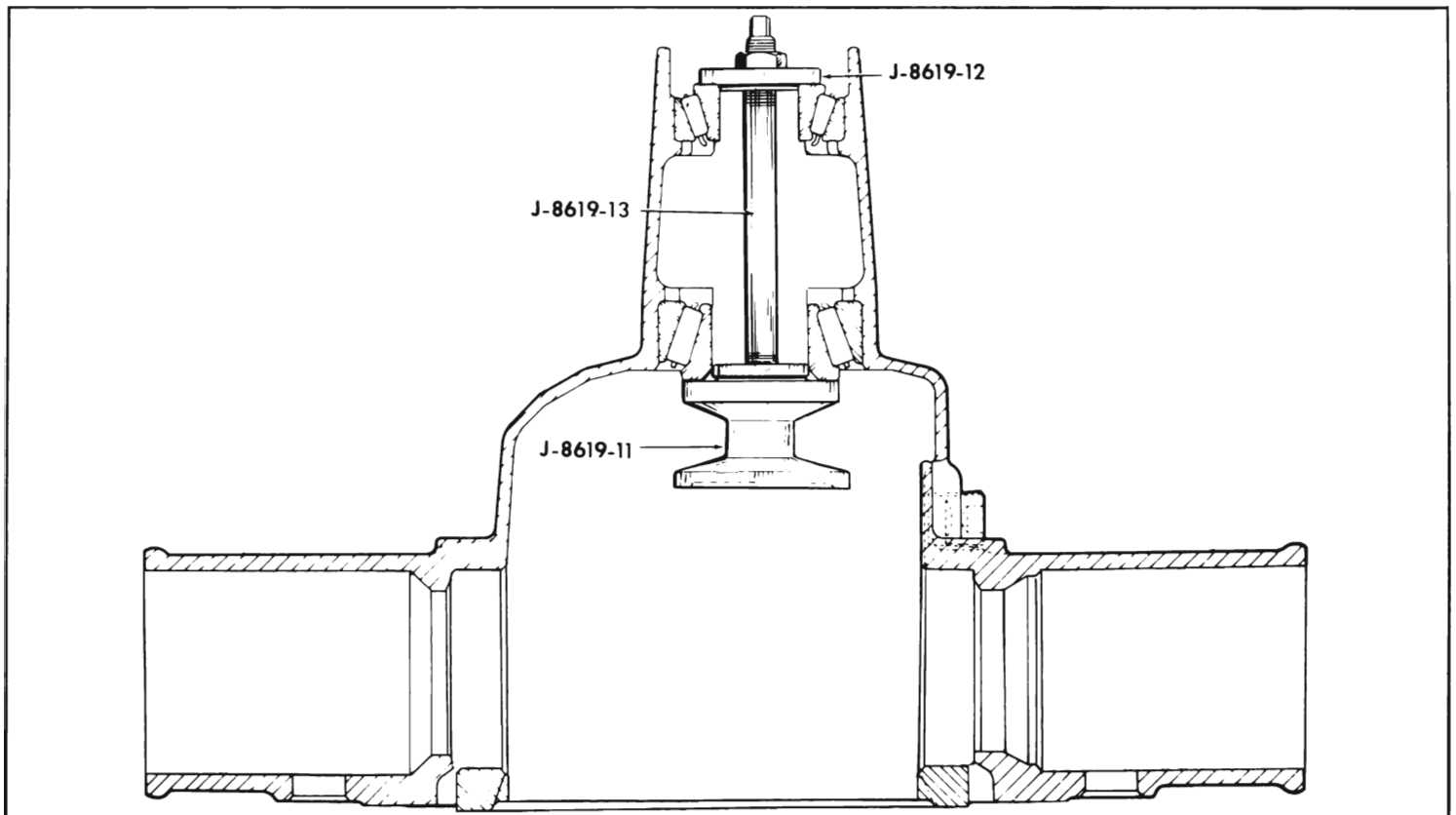

Figure 6-21—Securing Gauge Plate In Carrier

Set up pinion setting gauge as follows:

1. Make certain all of the gauge parts are clean, particularly the disks and center of the indicator gauge; also check the centering hole and disk pads on the master gauge.

2. Install the J-8619-10 Disks on the indicator gauge. Install the small contact button on the stem of the dial indicator and mount the dial indicator on the indicator gauge. See Figure 6-19.

3. Place the indicator gauge on the master gauge, as shown in Figure 6-20 so that the spring loaded center is engaged in the centering hole, and the inner, large diameter portion of each disk contacts the master gauge pads.

4. Center the indicator contact button on the indicator pad and lock the indicator by tightening the thumb screw.

5. Hold yoke down firmly, with both disks contacting the horizontal and vertical pads on master gauge, and set master gauge at zero.

6. Lubricate front and rear pinion bearings; then position them in their respective races in the carrier. While holding bearings in place, install Gauge Plate J-8619-11 in carrier on rear pinion bearing inner race as shown in Figure 6-21 and place pilot on surface of front pinion bearing. Insert Stud J-8619-13 through pilot, front and rear bearings, and thread it into gauge plate. See Figure 6-21.

7. Install nut on Stud J-8619-13. Hold stud stationary with wrench positioned over flats on ends of stud and tighten nut until a reading of 15-20 inch pounds is obtained when rotating gauge plate assembly with an inch pound torque wrench.

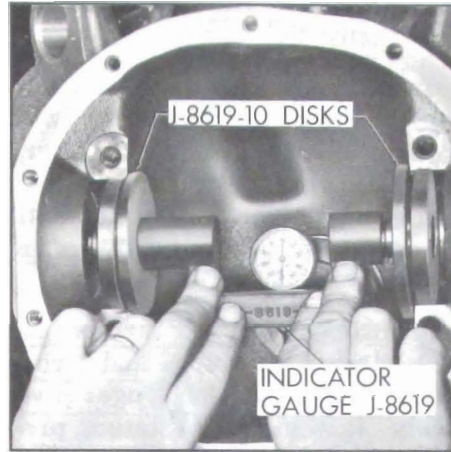

Figure 6-22—Checking Pinion Depth

8. Make certain differential bearing support bores are free of burrs. Install indicator gauge in carrier so that small diameter outer portion of disks rest in differential bearing pedestal support bores. Spring loaded center of gauge must be located in centering hole of gauge plate, and contact button of dial indicator must be positioned to bear against outer edge of gauge plate top surface. See Figure 6-22.

9. Press gauge yoke down firmly toward gauging plate; record the number of thousandths the dial moves from zero. Remove indicator gauge and recheck "zero setting" on master gauge to make sure this setting was not disturbed by handling.

10. If zero setting is still correct, remove gauging set up and both bearings from the carrier.

11. Examine the ring gear for nicks, burrs, or scoring. Any of these conditions will require replacement of the gear set.

12. Select the correct pinion shim to be used during pinion reassembly on the following basis:

(a) If the production pinion is being reused and the pinion is marked "+" (plus), the correct shim will have a thickness equal to the indicator gauge reading

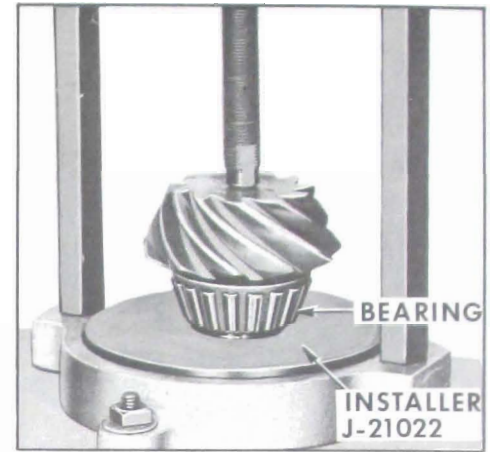

Figure 6-23—Installing Rear Pinion Bearing

found in Step 9 less the amount specified on the pinion.

(b) If the production pinion is being reused and the pinion is marked "-" (minus), the correct shim will have a thickness equal to the indicator gauge reading found in Step 9, plus the amount specified on the pinion.

(c) If a service pinion is being used (no marking), the correct shim will have a thickness equal to the indicator gauge reading found in Step 9.

13. Position correct shim on pinion shaft and install rear pinion bearing. Use Installer J-21022 as shown in Figure 6-23.

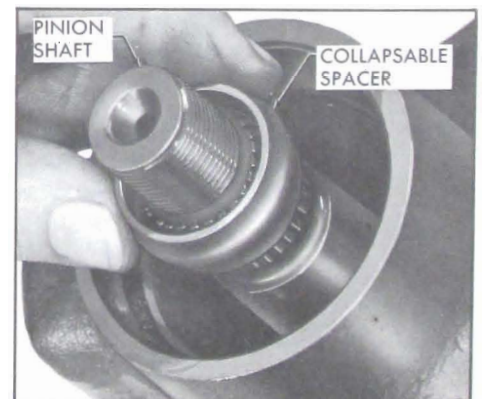

Figure 6-24—Installing Collapsible Spacer

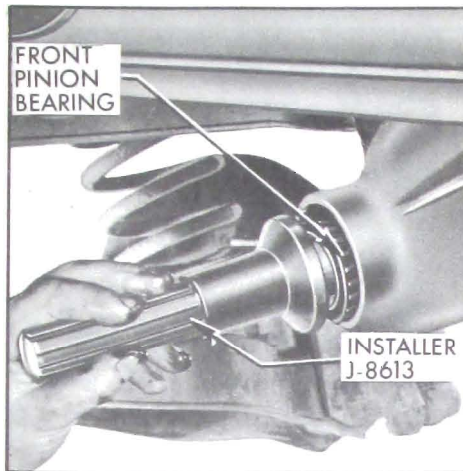

Figure 6-25—Installing Front Pinion Bearing

c. Install Pinion Assembly and Adjust Pinion Preload

1. Position pinion assembly in carrier and install collapsible spacer as shown in Figure 6-24.
2. Place front pinion bearing in position on pinion. Hold pinion fully forward and drive bearing over pinion until seated. Use Installer J-21128. See Figure 6-25.
3. Install pinion oil seal in carrier. Coat O.D. of seal with sealing compound. Install seal by using Installer J-21128. See Figure 6-26.
4. Coat lips of pinion oil seal; seal surface of pinion flange with gear lube. Install pinion flange on pinion by tapping with a soft

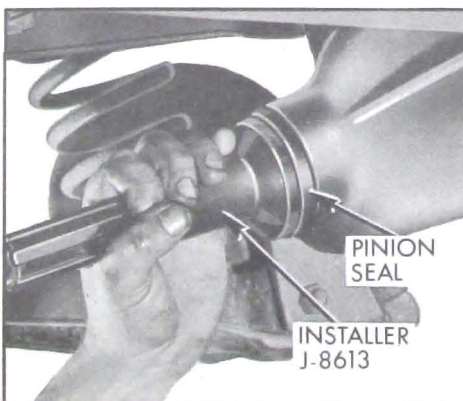

Figure 6-26—Installing Pinion Oil Seal

hammer until a few pinion threads project through flange.

5. Install pinion washer and nut. Hold companion flange with Holder J-8614-01. While intermittently rotating pinion to seat bearings, tighten pinion nut until end play begins to be taken up. See Figure 6-27.

CAUTION: When no further end play is detectable, and when Holder J-8614 will no longer pivot freely as pinion is rotated, preload specifications are being neared. Further tightening should be done only after preload has been checked.

6. Check preload by using an inch pound torque wrench as shown in Figure 6-28.

CAUTION: After preload has been checked, final tightening should be done very cautiously. For example, if when checking, preload was found to be 5 inch pounds, additional tightening of the pinion nut as little as 1/8 turn can add 5 additional inch pounds drag. Therefore, the pinion nut should be further tightened only a little at a time and preload should be checked after each slight amount of tightening. Exceeding preload specifications will compress the collapsible spacer too far and require its replacement.

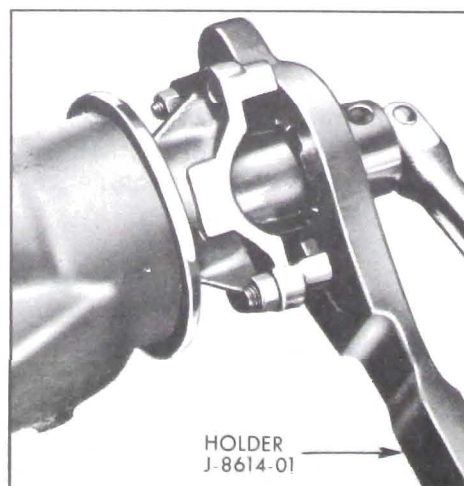

Figure 6-27—Installing Pinion Nut

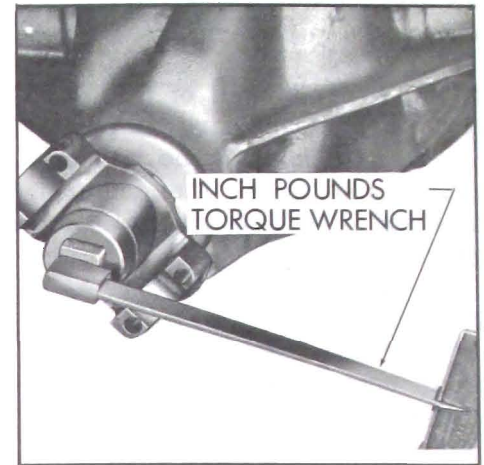

Figure 6-28—Checking Pinion Bearing Preload

7. While observing the preceding caution, carefully set preload drag at 20 to 30 inch pounds on new bearings or 12 to 20 inch pounds on used bearings.
8. Rotate pinion several times to assure that bearings have been seated. Check preload again. If drag has been reduced by rotating pinion, re-set preload to specification.

d. Assemble Differential Case Assembly

Before assembling the differential, examine the wearing surfaces of all parts for scoring or unusual wear. Also make certain that all parts are absolutely clean. Lubricate parts with rear axle lubricant just before assembly.

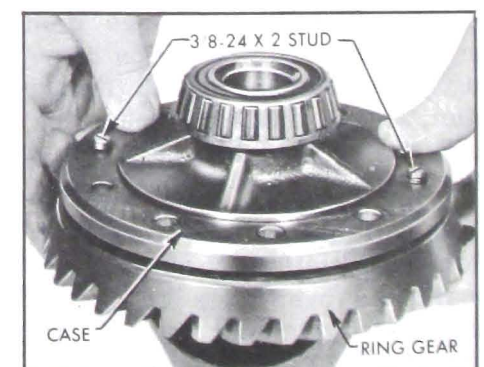

Figure 6-29—Installing Ring Gear On Differential Case

1. Place side gear thrust washers over side gear hubs and install side gears in case. If same parts are reused, replace in original sides.

2. Position one pinion (without washer) between side gears and rotate gears until pinion is directly opposite from loading opening in case. Place other pinion between side gears so that pinion axle holes are in line, then rotate gears to make sure holes in pinions will line up with holes in case.

3. If holes line up, rotate pinions back toward loading opening just enough to permit sliding in pinion thrust washers.

4. Install pinion axle. Install pinion axle retaining bolt. Torque to 20-28 ft. lbs.

5. After making certain that mating surfaces of case and ring gear are clean and free of burrs, thread two 3/8-24 x 2 studs into opposite sides of ring gear, then install ring gear on case. See Figure 6-29. Install ring gear attaching bolts just snug. Torque bolts alternately in progressive stages to 50-60 ft. lbs.

6. If differential side bearings were removed, install new bearings using Installer J-21132 with Driver Handle J-8092. See Figure 6-30.

e. Install Differential Case and Adjust Side Bearing Preload

Differential side bearing preload is adjusted by changing the thickness of both the right and left shims by an equal amount. By changing the thickness of both shims equally, the original backlash will be maintained. Differential adjusting shims are available in thicknesses ranging from .040" to .082" by two thousandths.



Figure 6-30—Installing Differential Side Bearings

1. Before installation of case assembly, make sure that side bearing surfaces in carrier are clean and free of burrs. Side bearings must be oiled with gear lube, and if same bearings are being reused, they must have original outer races in place.

2. Place differential case and bearing assembly in position in carrier. If new side bearings were installed, use original adjusting shims; if same bearings are to be reused, select new right and left adjusting shims each .002" thicker than original shim. Slip left shim in position at left bearing, then drive right shim carefully into position using a soft hammer. See Figure 6-31.

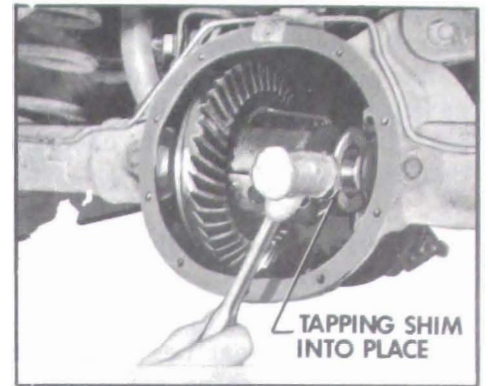

Figure 6-31—Installing Differential Adjusting Shim

3. As a safety precaution, install bearing caps using four 7/16-14 x 4-1/4 cylinder head bolts.

4. Rotate differential case several complete turns to seat bearings. Check bearing preload using an inch pound torque wrench connected at ring gear attaching bolt. With wrench projecting approximately straight out, bearing preload should read 30 to 40 in. lbs. with new bearings, or 20 to 30 in. lbs. with reused bearings. See Figure 6-32. If preload is not according to these specifications, increase shim thickness on each side .002" for each additional 10 in. lbs. preload desired, or decrease shim thickness .002" on each side for each 10 in. lbs. preload to be subtracted.

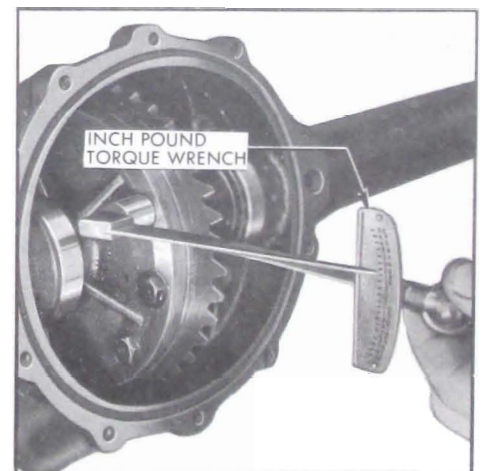

Figure 6-32—Checking Differential Case Preload

5. When preload is correctly adjusted, leave four safety head bolts and caps in position as a safety precaution while performing following backlash checking operation.

f. Adjust Differential Backlash

1. Rotate differential case several times to seat bearings, then mount dial indicator as shown in Figure 6-33. Use a small button on indicator stem so that contact can be made near heel end of tooth. Set dial indicator so that stem is as nearly as possible in line with gear rotation and perpendicular to tooth angle for accurate backlash reading.

2. With pinion locked to carrier, check gear lash at 3 or 4 points around ring gear. Lash must not vary over .001" around ring gear.

If variation is over .001" check for burrs, uneven bolting conditions or distorted case flange, and make corrections as necessary.

3. Gear lash at the point of minimum lash should be .007" to .009" for all new gears. If adjustment is necessary, adjust to .008".

If original gear set having a wear pattern is being reinstalled, original gear lash should be maintained within $\pm .001$ ".

4. If gear backlash is not within specifications, correct by increasing thickness of one differential shim and decreasing thickness of other shim the same amount. In this way, correct differential bearing preload will be maintained.

Shift .002" in shim thickness for each .001" change in backlash desired. If backlash is .001" too much, decrease thickness of right shim .002" and increase thickness of left shim .002". If backlash is .002" too little, increase thickness of right shim .004" and decrease thickness of left shim .004".

5. When gear backlash is correctly adjusted, remove 4 safety head bolts and install bearing caps according to markings. Torque bearing cap bolts to 40-65 ft. lbs.

6. Install new gasket in housing using heavy grease to retain it in place. Install cover. Torque cover bolts to 25-35 ft. lbs. Wait 20 minutes and retorque cover bolts to specification.

g. Install Axle Shaft Assemblies

1. Apply a coat of wheel bearing grease in bearing recesses of housing. Install new outer retainer gaskets. Apply a thin coating of Permatex #2 or equivalent to outer diameter of seal if replaced. To help prevent damage to the lip of the wheel seal when

installing axle shaft and to ensure lubricant on the seal lip during the first few miles of operation, the axle shaft should be lightly lubricated with axle lubricant from the sealing surface to approximately 6 inches inboard of the shaft. Insert axle shaft assemblies carefully until shaft splines engage in differential to avoid damage to seals.

2. Drive axle shaft assemblies into position.

3. Place gasket and retainer over studs and install nuts. Torque nuts to 60 ft. lbs.

4. Install brake drums over wheel bolts.

5. Install wheels and tighten wheel nuts.

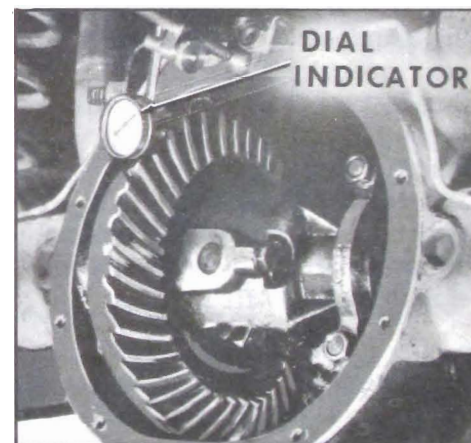

Figure 6-33—Checking Ring Gear To Pinion Backlash