

SECTION 2-E REPLACEMENT OF CRANKSHAFT AND CONNECTING ROD BEARINGS, PISTONS AND RINGS

CONTENTS OF SECTION 2-E

Paragraph	Subject	Page	Paragraph	Subject	Page
2-17	Replacement of Connecting Rod Bearings	2-30	2-19	Replacement of Pistons, Rings and Connecting Rods	2-33
2-18	Replacement of Crankshaft Bearings	2-31			

2-17 REPLACEMENT OF CONNECTING ROD BEARINGS

A connecting rod bearing consists of two halves or shells which are alike and interchangeable in rod and cap. When the shells are placed in rod and cap the ends extend slightly beyond the parting surfaces so that when rod bolts are tightened the shells will be clamped tightly in place to insure positive seating and to prevent turning. The ends of shells must never be filed flush with parting surface of rod or cap.

If a precision type connecting rod bearing becomes noisy or is worn so that clearance on crankpin is excessive, a new bearing of proper size must be selected and installed since no provision is made for adjustment. Under no circumstances should the connecting rod or cap be filed to adjust the bearing clearance.

a. Inspection of Connecting Rod Bearings and Crankpin Journals

After removal of lower crankcase, (par. 2-24 subpar. d) disconnect two connecting rods at a time from crankshaft and inspect the bearings and crankpin journals. While turning crankshaft it is necessary to temporarily reconnect the rods to crankshaft to avoid possibility of damaging the journals through contact with loose rods.

If connecting rod bearings are chipped or scored they should be replaced. If bearings are in good physical condition check for proper clearance on crankpin as described in subparagraph b, below.

If crankpin journals are scored or ridged the crankshaft must be replaced, or reground for undersize bearings, to insure satisfactory life of connecting rod bearings. Slight roughness may be polished out with fine grit polishing cloth thoroughly wetted with engine oil. Burrs may be honed off with a fine oil stone.

Use an outside micrometer to check crankpins for out-of-round. If crankpins are more than .0015" out-of-round, satisfactory life of new bearings cannot be expected.

b. Checking Clearance and Selecting Replacement Bearings

Service bearings are furnished in standard size and several undersizes (including undersizes for reground crsnkpins).

The clearance of connecting rod (and crankshaft) bearings may be checked by use of Plastigage, Type PG-1 (green), which has a range of .001" to .003". Plastigage is manufactured by Perfect Circle Corporation, and is available through General Motors parts warehouses.

1. Remove connecting rod cap with bearing shell. Wipe oil from bearing and crankpin journal, also blow oil out of hole in crankshaft. NOTE: Plastigage is soluble in oil.

2. Place a piece of Plastigage lengthwise along the bottom center of the lower bearing shell (Figure 2-41, View A), then install cap with shell and tighten bolt nuts to 30-35 ft. lbs. torque. NOTE: The rib on edge of cap and the conical boss on web of rod must be toward rear of engine on all rods in left bank and toward front of engine in right bank.

3. **DO NOT TURN CRANKSHAFT** with Plastigage in bearing.

4. Remove bearing cap with bearing shell, the flattened Plastigage will be found adhering to either the bearing shell or the crankpin. Do not remove it.

5. Using the scale printed on the Plastigage envelope, measure the

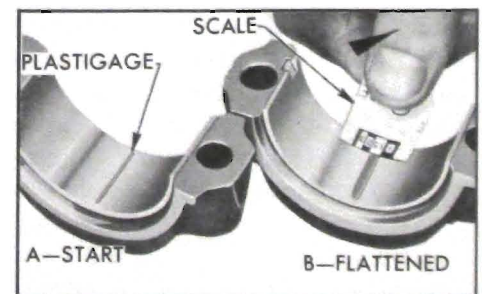

Figure 2-41—Checking Bearing Clearance With Plastigage

flattened Plastigage at its widest point. The number within the graduation which most closely corresponds to the width of Plastigage indicates the bearing clearance in thousandths of an inch. See Figure 2-41, View B.

6. The desired clearance with a new bearing is .0002" to .0023". If bearing has been in service it is advisable to install a new bearing if the clearance exceeds .003"; however, if bearing is in good condition and is not being checked because of bearing noise, it is not necessary to replace the bearing.

7. If a new bearing is being selected, try a standard size, then each undersize bearing in turn until one is found that is within the specified limits when checked for clearance with Plastigage. **NOTE: Each undersize bearing shell has a number stamped on outer surface on or near the tang to indicate amount of undersize.**

8. After the proper size bearing has been selected, clean off the Plastigage, oil the bearing thoroughly, reinstall cap with bearing shell and tighten bolt nuts to 40-45 ft. lbs. torque. **See NOTE in Step 2.**

9. With selected bearing installed and bolts tightened, it should be possible to move connecting rod freely back and forth on crankpin as allowed by end clearance. If rod cannot be moved, either the bearing is too much undersize or a misaligned rod is indicated.

2-18 REPLACEMENT OF CRANKSHAFT BEARINGS

A crankshaft bearing consists of two halves or shells which are not alike and not interchangeable in cap and crankcase. The upper (crankcase) half of the bearing is grooved to supply oil to the connecting rod bearings while the lower (bearing cap) half of the shell is not grooved. The two

bearing halves must not be interchanged. All crankshaft bearings except the thrust bearing are identical. The thrust bearing (Center on V-8, #2 or V-6) is longer and flanged to take end thrust. When the shells are placed in crankcase and bearing cap, the ends extend slightly beyond the parting surfaces so that when cap bolts are tightened the shells will be clamped tightly in place to insure positive seating and to prevent turning. The ends of shells must never be filed flush with parting surface of crankcase or bearing cap.

If the thrust bearing shell is disturbed or replaced it is necessary to line up the thrust surfaces of the bearing shell before the cap bolts are tightened. To do this, move the crankshaft fore and aft the limit of its travel several times with the bearing cap bolts finger tight.

Crankshaft bearings are the precision type which do not require reaming to size or other fitting. Shims are not provided for adjustment since worn bearings are readily replaced with new bearings of proper size. Bearings for service replacement are furnished in standard size and undersizes. Under no circumstances should crankshaft bearing caps be filed to adjust for wear in old bearings.

a. Inspection of Crankshaft Bearings and Crankshaft

After removal of lower crankcase, oil pump pipe and screen and flywheel lower housing (synchromesh) or bell housing cover (automatic transmission) perform the following removal, inspection and installation operations on each crankshaft bearing in turn so that the crankshaft will be well supported by the other bearings.

NOTE: If crankshaft has been removed to check straightness the following procedure is suggested.

Rest crankshaft on "veeblocks" at number one and number five main bearing journals. Check indicator runout at No. 2, 3 and 4 main bearing journals. Total indicator readings at each journal should not exceed .003".

While checking runout at each journal note relation of "high" spot (or maximum eccentricity) on each journal to the others. "High" spot on all journals should come at the same angular location. If "high" spots do not come at nearly the same angular location, crankshaft has a "crook" or "dogleg" in it and is unsatisfactory for service.

1. Since any service condition which affects the crankshaft bearings may also affect the connecting rod bearings, it is advisable to inspect connecting rod bearings first (par. 2-17). If crankpins are worn to the extent that crankshaft should be replaced or reground, replacement of crankshaft bearings only will not be satisfactory.

2. Remove one bearing cap, then clean and inspect lower bearing shell and the crankshaft journal. If journal surface is scored or ridged, the crankshaft must be replaced or reground to insure satisfactory operation with new bearings. Slight roughness may be polished out with fine grit polishing cloth thoroughly wetted with engine oil, and burrs may be honed off with a fine stone.

3. If condition of lower bearing shell and crankshaft journal is satisfactory, check the bearing clearance with Plastigage as described for connecting rod bearings in paragraph 2-17.

4. When checking a crankshaft bearing with Plastigage, turn crankshaft so that oil hole is up to avoid dripping of oil on Plastigage. Place paper shims in lower halves of adjacent bearings and

tighten cap bolts to take the weight of crankshaft off the lower shell of bearing being checked.

5. If bearing clearance exceeds .003", it is advisable to install a new bearing; however, if bearing is in good condition and is not being checked because of bearing noise, it is not necessary to replace the bearing.

b. Selection and Installation of a New Crankshaft Bearing

1. Loosen all crankshaft bearing cap bolts 1/2 turn, and remove cap of bearing to be replaced.

2. Remove upper bearing shell by inserting Bearing Shell Remover and Installer J-8080 in oil hole in crankshaft, then slowly turning crankshaft so that the tool rotates the shell out of place by pushing against the end without the tang. See Figure 2-42. CAUTION: When turning crankshaft with rear bearing cap removed hold oil seal to prevent it from rotating out of position in crankcase.

3. The crankshaft journal cannot be measured with an outside micrometer when shaft is in place; however, when upper bearing shell is removed the journal may be checked for out-of-round by using a special crankshaft caliper and inside micrometer. The caliper should not be applied to journal in line with oil hole.

If crankshaft journal is more than .0015" out-of-round, the crankshaft should be replaced since the full mileage cannot be expected from bearings used with an excessively out-of-round crankshaft.

4. Before installation of bearing shells make sure that crankshaft journal and the bearing seats in crankcase and cap are thoroughly cleaned.

5. Coat inside surface of upper bearing shell with engine oil and

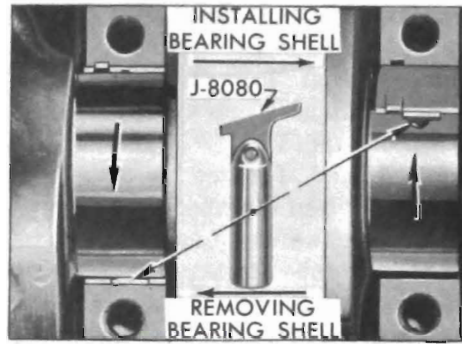

Figure 2-42—Removing and Installing Crankshaft Bearing Upper Shell

place shell against crankshaft journal so that tang on shell will engage notch in crankcase when shell is rotated into place. IMPORTANT: Upper bearing shells have an oil groove in their center, while lower shells are plain. They must not be interchanged.

6. Rotate bearing shell into place as far as possible by hand, then insert Installer J-8080 in crankshaft oil hole and rotate crankshaft to push shell into place. CAUTION: Bearing shell should move into place with very little pressure. If heavy pressure is required, shell was not started squarely and will be distorted if forced into place.

7. Place lower bearing shell in bearing cap, then check clearance with Plastigage as previously described.

8. The desired clearance with a new bearing is .0005" to .0025". If this clearance cannot be obtained with a standard size bearing, insert an undersize bearing and check again with Plastigage. NOTE: Each undersize shell has a number stamped on outer surface on or near the tang to indicate amount of undersize.

9. When the proper size bearing has been selected, clean out all Plastigage, oil the lower shell and reinstall bearing cap. Clean the bolt holes and lube bolts, then torque cap bolts to specification given in paragraph 2-1. The

crankshaft should turn freely at flywheel rim; however, a very slight drag is permissible if an undersize bearing is used.

10. If the thrust bearing shell is disturbed or replaced it is necessary to line up the thrust surfaces of the bearing shell before the cap bolts are tightened. To do this, move the crankshaft fore and aft the limit of its travel several times with the thrust bearing cap bolts finger tight.

11. After bearing is installed and tested, loosen all bearing cap bolts 1/2 turn and continue with other bearings. When bearings have been installed and tested, tighten all bearing cap bolts to specification given in paragraph 2-1.

c. Installation of Rear Bearing Oil Seals

Braided fabric seals are pressed into grooves formed in crankcase and rear bearing cap to rear of the oil collecting groove, to seal against leakage of oil around the crankshaft.

Neoprene composition seals are placed in grooves in the sides of bearing cap to seal against leakage in the joints between cap and crankcase. The neoprene composition swells in the presence of oil and heat. The seals are undersize when newly installed and may even leak for a short time until the seals have had time to swell and seal the opening. See Figure 2-45.

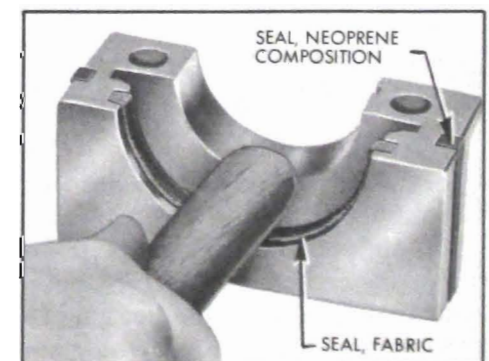

Figure 2-43—Rear Bearing Oil Seals

The braided fabric seal can be installed in crankcase only when crankshaft is removed; however, the seal can be replaced in cap whenever cap is removed. Remove old seal and place new seal in groove with both ends projecting above parting surface of cap. Force seal into groove by rubbing down with hammer handle or smooth stick until seal projects above the groove not more than 1/16". Cut ends off flush with surface of cap, using sharp knife or razor blade. Lube the seal with heavy engine oil just before installation. See Figure 2-43. **CAUTION:** The engine must be operated at slow speed when first started after new braided seal is installed.

The neoprene composition seals are slightly longer than the grooves in the bearing cap. The seals must not be cut to length. Just before installation of bearing cap in crankcase, lightly lubricate the seals and install in bearing cap with upper end protruding approximately 1/16".

After cap is installed, force seals up into the cap with a blunt instrument to be sure of a seal at the upper parting line between the cap and case.

d. Installation of Oil Pump, Pipe and Screen Assembly and Lower Crankcase

1. Install oil pump, pipe and screen assembly following procedure given in paragraph 2-24.

2. Thoroughly clean lower crankcase and flywheel lower housing and bell housing cover before installation. Use new gaskets when installing lower crankcase and flywheel lower housing.

3. Reinstall steering idler arm to front cross member bolts, nuts and washers as illustrated in Figure 8-96.

2-19 REPLACEMENT OF PISTONS, RINGS, AND CONNECTING RODS

a. Removal and Disassembly of Piston and Rod Assemblies

1. Remove cylinder heads (par. 2-14).

2. Examine the cylinder bores above the ring travel. If bores are worn so a shoulder or ridge exists at this point, remove the ridges with a ridge reamer to avoid damaging rings or cracking ring lands in pistons during removal.

3. Use a silver pencil or quick drying paint to mark the cylinder number on all pistons, connecting rods and caps. Starting at the front end of the crankcase the cylinders in the right bank are numbered 2-4-6-8 and in the left bank are numbered 1-3-5-7.

4. Remove cap and bearing shell from number 1 connecting rod. Install connecting rod bolt guides on the bolts to hold the upper half of the bearing shell in place. See Figure 2-44.

5. Push the piston and rod assembly up out of the cylinder. Then remove guides and reinstall cap and bearing shell on rod.

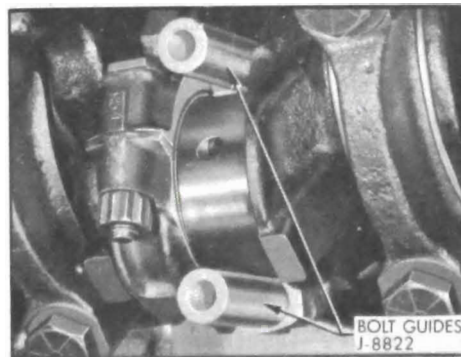

Figure 2-44—Connecting Rod Bolt Guides Installed

6. Remove other rod and piston assemblies in same manner.

7. Remove compression rings with expander and remove oil ring by removing the two rails, and spacer-expander which are separate pieces in each piston third groove. See Figures 2-51 and 2-52.

8. To remove piston pin:

(a) Assemble press as shown in Figure 2-53. Install Piston Pin pilot J-6047-20 in base. Install support with full radial face up. Set spring in support.

(b) Set piston, pin and rod in press with J-8355 inserted in piston pin.

(c) Press out piston pin.

b. Inspection of Cylinder Bores

Inspect cylinder walls for scoring, roughness, or ridges which indicate excessive wear. Check cylinder bores for taper and out-of-round with an accurate cylinder gauge at top, middle and bottom of bore, both parallel and at right angles to the centerline of the engine. The diameter of the cylinder bores at any point may be measured with an inside micrometer or by setting the cylinder gauge dial at "O" and measuring across the gauge contact points with outside micrometer while the gauge is at same "O" setting.

If a cylinder bore is moderately rough or slightly scored but is not out-of-round or tapered, it is usually possible to remedy the situation by honing the bore to fit a standard service piston since standard service pistons are high limit production pistons. If cylinder bore is very rough or deeply scored, however, it may be necessary to rebore the cylinder to fit an oversize piston in order to insure satisfactory results.

If cylinder bore is tapered .005" or more or is out of round .003"

or more, it is advisable to rebore for the smallest possible oversize piston and rings.

c. Inspection of Pistons, Rings and Pins

Clean carbon from piston surfaces and under side of piston heads. Clean carbon from ring grooves with suitable tool and remove any gum or varnish from piston skirts with suitable solvent.

Carefully examine pistons for rough or scored bearing surfaces, cracks in skirt or head cracked or broken ring lands, chipping or uneven wear which would cause rings to seat improperly or have excessive clearance in ring grooves. Damaged or faulty pistons should be replaced.

The pistons are cam ground, which means that the diameter at a right angle to the piston pin is greater than the diameter parallel to the piston pin. When a piston is checked for size, it must be measured with micrometers applied to the skirt at points 90° to the piston pin. See Figure 2-54. The piston should be measured (for fitting purposes) 1/4 below the bottom of the oil ring groove.

Inspect bearing surfaces of piston pins and check for wear by measuring worn and unworn surfaces with micrometers. Rough or worn pins should be replaced. Test fit of piston pins in piston bosses. Occasionally pins will be found tight due to gum or varnish deposits. This may be corrected by removing the deposit with a suitable solvent. If piston bosses are worn out-of-round or oversize, the piston and pin assembly must be replaced. Oversize pins are not practical due to the pin being a press fit in the connecting rod. Piston pins must fit the piston with an easy finger push at 70°F (.0003" to .0005" clearance).

Examine all piston rings for scores, chips or cracks. Check compression rings for tension by comparing with new rings. Check gap of compression rings by placing rings in bore at bottom of ring travel. Measure gap with feeler gauge. Gap should be between .010" and .020". If gaps are excessive (over .020") it indicates the rings have worn considerably and should be replaced.

d. Reboring Cylinders and Fitting New Piston

If one or more cylinder bores are rough, scored, or worn beyond limits prescribed under Inspection of Cylinder Bores (subpar. b), it will be necessary to smooth or true up such bores to fit new pistons.

If relatively few bores require correction it will not be necessary to rebore all cylinders to the same oversize in order to maintain engine balance, since all oversize service pistons are held to the same weights as standard size pistons. If conditions justify replacement of all pistons, however, all new pistons should be the same nominal size.

Standard size service pistons are high limit or maximum diameter; therefore, they can usually be used with a slight amount of honing to correct slight scoring or excessive clearances in engines having relatively low mileage. Service pistons are also furnished in .010" oversize. All service pistons are diamond bored and selectively fitted with piston pins; pistons are not furnished without pins.

No attempt should be made to cut down oversize pistons to fit cylinder bores as this will destroy the surface treatment and affect the weight. The smallest possible oversize service pistons should be used and the cylinder bores

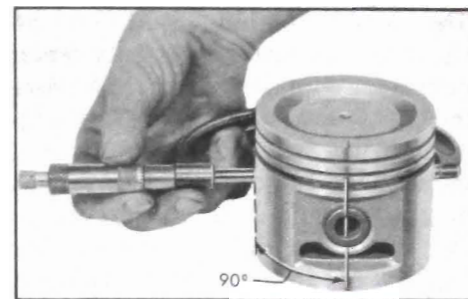

Figure 2-45—Measuring Piston

should be honed to size for proper clearances.

Before the honing or reboring operation is started, measure all new pistons with micrometer contacting at points exactly 90 degrees to piston pin (Figure 2-45) then select the smallest piston for the first fitting. The slight variation usually found between pistons in a set may provide for correction in case the first piston is fitted too free.

If wear at top of cylinder does not exceed .005" on the diameter or exceed .003" out-of-round, honing is recommended for truing the bore. If wear or out-of-round exceeds these limits, the bore should be trued up with a boring bar of the fly cutter type, then finish honed.

When reboring cylinders, all crankshaft bearing caps must be in place and tightened to proper torque to avoid distortion of bores in final assembly. Always be sure the crankshaft is out of the way of the boring cutter when boring each cylinder. When taking the final cut with boring bar leave .001" on the diameter for finish honing to give the required clearance specified below.

When honing cylinders use clean sharp stones of proper grade for the amount of metal to be removed, in accordance with instructions of the hone manufacturer. Dull or dirty stones cut unevenly and generate excessive

heat. When using coarse or medium grade stones use care to leave sufficient metal so that all stone marks may be removed with the fine stones used for finishing to provide proper clearance.

When finish honing, pass the hone through the entire length of cylinder at the rate of approximately 60 cycles per minute. This should produce the desired 45 degree cross hatch pattern on cylinder walls which will insure maximum ring life and minimum oil consumption.

It is of the greatest importance that refinished cylinder bores are trued up to have not over .0005" out-of-round or taper. Each bore must be final honed to remove all stone or cutter marks and provide a smooth surface. During final honing, each piston must be fitted individually to the bore in which it will be installed and should be marked to insure correct installation.

After final honing and before the piston is checked for fit, each cylinder bore must be thoroughly washed to remove all traces of abrasive and then dried thoroughly. The dry bore should then be brushed clean with a power-driven fibre brush. If all traces of abrasive are not removed, rapid wear of new pistons and rings will result. A satisfactory method of fitting pistons is as follows:

1. Expand a telescope gauge to fit the cylinder bore at right angles to the piston pin and between 1-1/2" and 2" from the top. See Figure 2-46.

2. Measure the telescope gauge. See Figure 2-47.

3. Measure the piston to be installed. See Figure 2-45. The piston must be measured at right angles to the piston pin 1/4" below the oil ring groove. The piston must be between .001" and

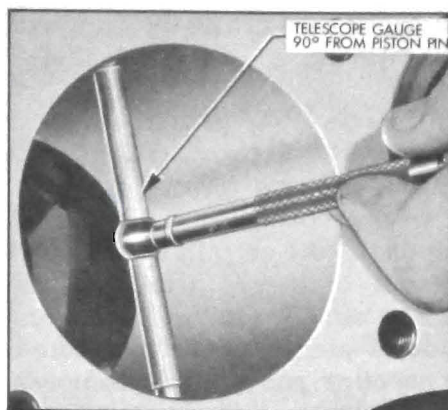

Figure 2-46—Using Telescope Gauge in Cylinder Bore

.0015" smaller than the cylinder bore.

NOTE: Both block and piston must be at very nearly the same temperature when measurements are made or errors due to expansion will occur. A difference of 10°F between parts is sufficient to produce a variation of .0005".

e. Fitting New Piston Rings

When new piston rings are installed without reboring cylinders, the glazed cylinder walls should be slightly dulled, but without increasing the bore diameter, by means of the finest grade of stones in a cylinder hone.

New piston rings must be checked for clearance in piston grooves and for gap in cylinder bores; however, the flexible oil rings are

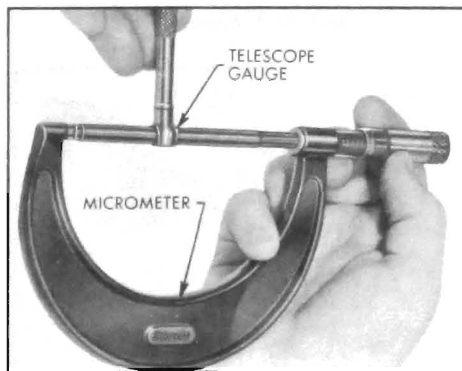

Figure 2-47—Measuring Telescope Gauge

not checked for gap. The cylinder bores and piston grooves must be clean, dry and free of carbon and burrs.

With rings installed, check clearance in grooves by inserting feeler gauges between each ring and its lower land because any wear that occurs forms a step at inner portion of the lower land. If the piston grooves have worn to the extent that relatively high steps exist on the lower lands, the piston should be replaced because the steps will interfere with the operation of new rings and the ring clearances will be excessive. Piston rings are not furnished in oversize widths to compensate for ring groove wear.

When fitting new rings to new pistons the side clearance of the compression rings should be .003" to .005" and side clearance of the oil ring should be .0035" to .0095".

To check the end gap of compression rings, place the ring in the cylinder in which it will be used, square it in the bore by tapping with the lower end of a piston, then measure the gap with feeler gauges. Piston rings should not have less than .015" gap when placed in cylinder bores. If gap is less than .015", file the ends of rings carefully with a smooth file to obtain proper gap.

f. Assembly and Installation of Piston and Connecting Rod Assemblies

NOTE: Connecting rods may be sprung out of alignment in shipping or handling. Always check a new rod before installing piston and pin.

Check bend and twist on an accurate rod aligning fixture using Guide Pin J-6047-16 (from wrist pin press set) in place of wrist pin. Press Vee block firmly and evenly against guide pin to prevent cocking pin in eye of rod which may be up to .002" loose on pin.

1. To assemble piston and pin to connecting rod, assemble press as shown in Figure 2-46 with full radial face of support J-8754-1 "up".
2. If the piston and rod assembly is to be installed in the left bank the assembly must be made as shown in Figure 2-48 or 2-49.
3. If the piston and rod is to be installed in the right bank, the assembly must be made as shown in Figure 2-50 or 2-51.
4. Assemble piston and rod on spring loaded guide pin.
5. Lubricate piston pin to avoid damage when pressing through the connecting rod.
6. Install drive pin in upper end of piston pin. Press on drive pin till piston pin bottoms.
7. Remove piston and rod assembly from press. Rotate piston on pin to be sure pin was not

8. Install V-8 piston rings as shown in Figure 2-52. Position expander ends over piston pin where groove is not slotted, and be absolutely certain that the ends do not overlap. Install oil ring rails with gaps "up" on same side of piston as oil spurt hole in connecting rod. Install compression rings in upper two grooves. If a single chrome plated compression ring is used, the chrome ring must be installed in the top groove.
9. Install V-6 piston rings as shown in Figure 2-53. Position expander ends over piston pin. Install oil ring rail spacer, and oil ring rails. Position gaps in rails "up" on same side of piston as oil spurt hole in connecting rod. Install compression rings in upper two grooves. If a single chrome plated compression ring is used, the chrome ring must be installed in the top groove.

10. Install compression rings in top and center groove. See Figures 2-52 and 2-53.

NOTE: All compression rings are marked with a dimple, a letter "T", a letter "O" or word "TOP" to identify the side of the ring which must be assembled toward the top of the piston. If a single chrome plated compression ring is used, the chrome ring must be installed in the top groove.

11. Make sure cylinder bores, pistons, connecting rod bearings and crankshaft journals are absolutely clean, then coat all bearing surfaces with engine oil.
12. Before installation of a piston and rod assembly in its bore, position the crankpin straight down.

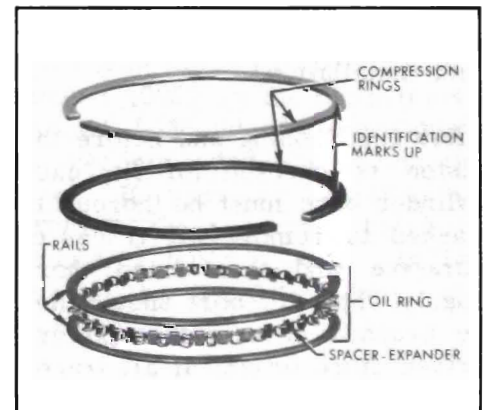
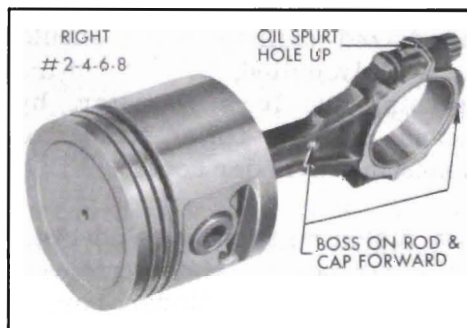
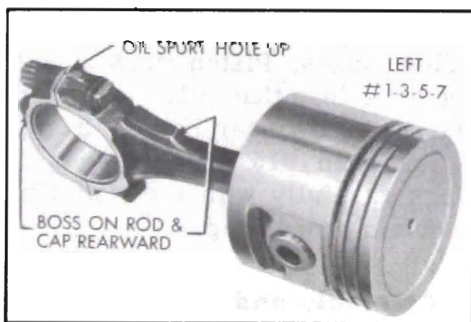

Figure 2-52—V-8 Piston Rings

Figure 2-48—V-8 Left Bank Piston and Rod Assembly

Figure 2-50—V-8 Right Bank Piston and Rod Assembly

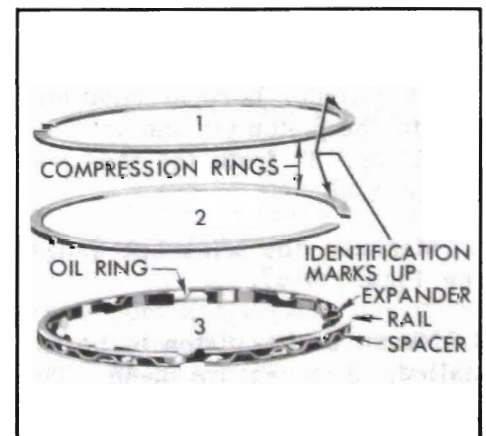
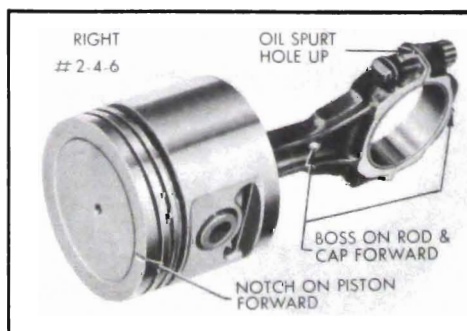
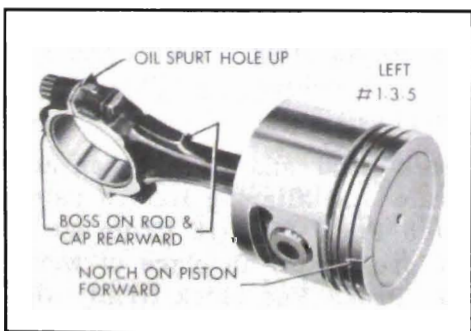

Figure 2-49—V-6 Left Bank Piston and Rod Assembly

Figure 2-51—V-6 Right Bank Piston and Rod Assembly

Figure 2-53—V-6 Piston Rings

13. Remove connecting rod cap, and with bearing upper shell seated in rod; install connecting rod guides. These guides hold the upper bearing shell in place and prevent damage to the crankpin during installation of the connecting rod and piston assembly.

14. Make sure the gap in the oil ring rails is "up" toward center of engine and the gaps of the compression rings are not in line with each other or the oil ring rails. Be certain the ends of the oil ring spacer-expander are butted together not lapped over.

15. Lubricate the piston and rings and install in bore by compressing the rings either with a "wrap around" compressor or a split ring type such as shown in Figure 2-54.

16. Select new connecting rod bearing, if necessary, as de-

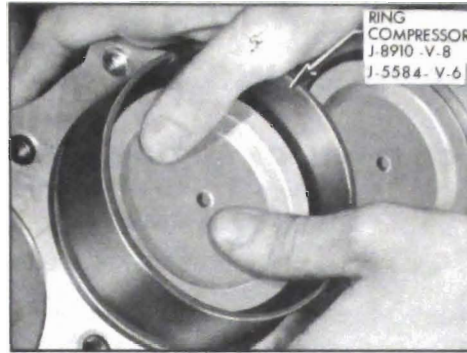

Figure 2-54—Installing Piston with Ring Compressor

scribed in paragraph 2-17. Otherwise install cap with bearing lower shell on rod and tighten bolt nuts to 30-35 ft. lbs. torque.

17. Install all other piston and rod assemblies in same manner. When piston and rod assemblies are properly installed, the oil spurt holes in the connecting rods will be "up" toward the camshaft, the rib on the edge of the

rod cap will be on the same side as the conical boss on the connecting rod web, and these marks, (rib and boss) will be toward the other connecting rod on the same crankpin. See Figures 2-48, 2-49, 2-50 and 2-51.

18. Check end clearance between connecting rods on each crankpin using feeler gauges. Clearance should be between .005" and .012".

19. Install cylinder heads (par. 2-14). Install oil screen and lower crankcase (Oil Pan).

IMPORTANT: After installation of new pistons and rings, care should be used in starting the engine and running it for the first hour. Avoid high speeds until the parts have had a reasonable amount of break in to avoid scuffing.