

SECTION 2-B ENGINE DESCRIPTION

CONTENTS OF SECTION 2-B

Paragraph	Subject	Page	Paragraph	Subject	Page
2-4	Engines and Mountings	2-7	2-6	Engine Lubrication System	2-11
2-5	Engine Construction	2-7	2-7	Engine Cooling System	2-12

2-4 ENGINES AND MOUNTINGS

A V-6 engine of 225 cubic inches displacement is standard equipment on 4041-4300 series cars. An optional 300 cubic inch displacement V-8 engine is available on 4041-4300 cars.

a. V-6 Engines

The same basic engine is used for both Synchromesh and automatic transmissions. Both engines have a bore of 3.750 inches and a stroke of 3.400 inches. Synchromesh transmission engines are equipped with a cast iron flywheel and flywheel housing, while automatic transmission engines are equipped with a stamped steel flywheel which is bolted to the transmission converter pump. All V-6 engines have 9.0 to 1 compression ratio pistons.

b. V-8 Engines

All V-8 engines are manufactured from the same basic components. All V-8 engines have a bore of 3.750 and a stroke of 3.400 . A cast iron flywheel for clutch application is installed when the engine is used with a Synchromesh transmission, while a stamped steel flywheel is installed when the engine is to be coupled to an automatic transmission. A four-port manifold and four-barrel carburetor are installed in conjunction with 11.0 to 1 compression ratio pistons when a "power pack" engine is specified. A two-port manifold and two-barrel carburetor is used

when standard compression ratio (9.0 to 1) or export (7.6 to 1) pistons are used.

c. Engine and Transmission Mounts

The engine and transmission assembly is supported on three synthetic rubber pads.

The front (engine) mountings are bolted between the engine crankcase and frame cross member. The front (engine) mountings support the weight of the engine and control its torsional characteristics.

The rear (transmission mounting) is located between the transmission and the transmission support. The rear mounting supports part of the weight of the engine and transmission assembly and locates the rear of the engine with respect to the centerline of the car.

2-5 ENGINE CONSTRUCTION

a. Cylinder Crankcase

The V-6 and V-8 cylinder crankcases are cast iron. Both crankcases have two banks of cylinders which form a 90° angle. The

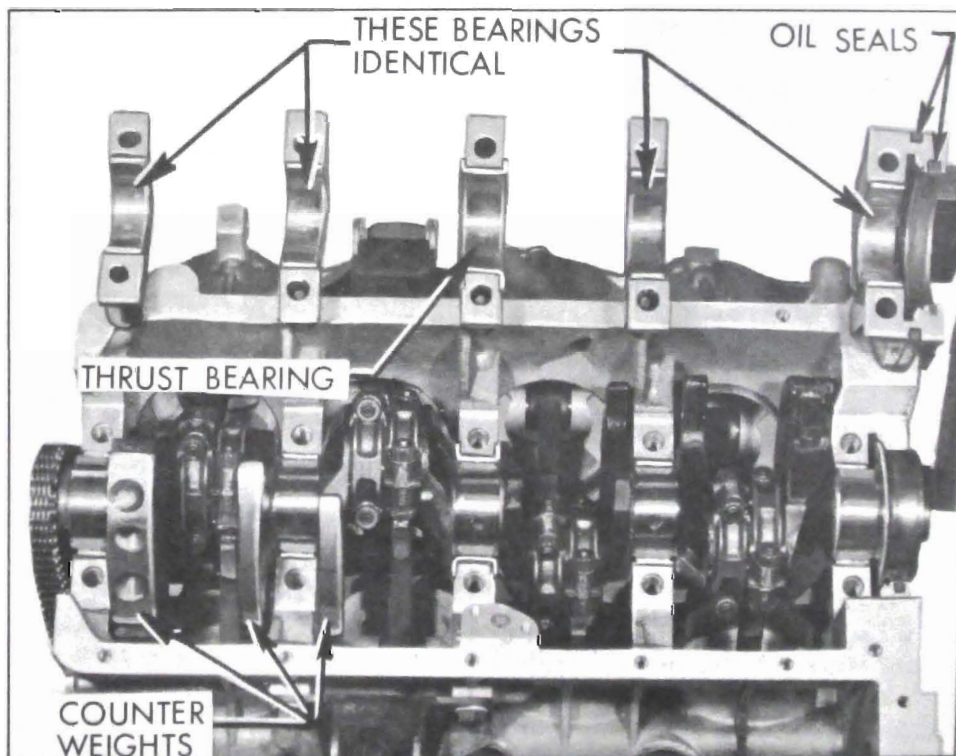

Figure 2-4—V-8 Engine Crankshaft and Bearings

crankcase section extends below the centerline of the crankshaft to form a continuous flat surface with the rear bearing cap and timing chain cover, permitting installation of the lower crankcase (oil pan) with one-piece gasket.

The left bank of cylinders (as viewed from the driver's seat) is set forward of the right bank so connecting rods of opposite pairs of pistons and rods may be connected to the same crankpin.

The cylinders in the left bank are numbered (from front to rear) 1 - 3 - 5, etc. Cylinders in the right bank are numbered (from front to rear) 2 - 4 - 6, etc.

b. Crankshaft and Bearings

The crankshaft is supported in the crankcase by steel-backed full precision bearings, all having the same nominal diameter. Except for the thrust bearing, all bearings are identical. The thrust bearing takes end thrust and has flanges for that purpose. Number 2 bearing in the V-6 engine and Number 3 bearing in the V-8 engine are the thrust bearings.

The crankshaft is counterbalanced by weights cast integral with the crank cheeks. Maximum counterweighting in the space available is accomplished by precision casting the counterweights to a contour which allows a minimum uniform clearance with cylinder barrels and piston skirts.

c. Connecting Rods and Pistons

Connecting rods are of I-beam section with bosses on each side so metal can be removed as required to secure correct weight and balance. The lower end of each rod is fitted with a steel-backed full precision-type bearing. The piston pin is a press fit into the upper end. The outer ends of the piston pin are a slide fit in the piston bosses.

The full skirted aluminum alloy pistons are cam ground and tin plated. Two compression rings and one oil control ring are located above the piston pin. The cast iron compression rings in the two upper grooves of the piston have a groove or bevel cut around the inner edge on one side.

The top compression rings are installed with this groove or bevel down. The lower compression ring is installed bevel up.

The oil ring in the lower groove consists of two thin steel rails separated by a spacer expander in V-8 engines and by a spacer in V-6 engines. V-6 engine oil rings are backed by a hump-type spring steel expander.

d. Cylinder Heads

V-8 cylinder heads are made of cast aluminum with iron valve seat inserts and valve stem guides. The valve stem guides are a press fit and are replaceable, while the valve seat inserts are shrunk fit at assembly and are nonreplaceable.

V-6 cylinder heads are cast iron with valve stem guides cast in place. Right and left cylinder heads are identical and interchangeable. Although, in service, it is good practice to replace the cylinder heads on the side from which they were removed.

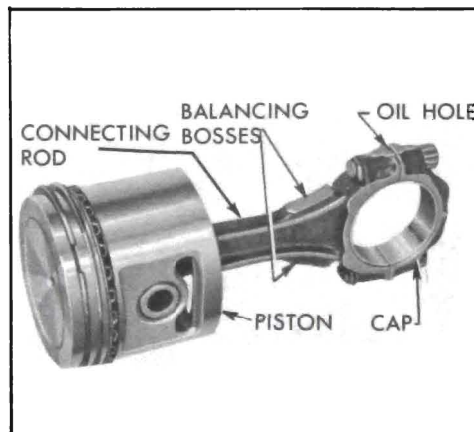

Figure 2-5—Connecting Rod and Piston Assembly

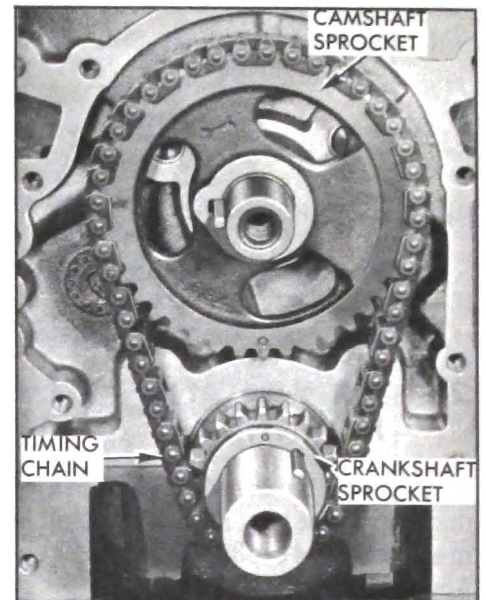

Figure 2-6—V-8 Timing Chain and Sprockets

The valves are in line in each head and operate at an angle 10° above the centerline of the cylinder bores. The spark plug in each cylinder is located so the point gap is ideally located with respect to the sweep of the incoming charge.

e. Camshaft and Valve Mechanism

The camshaft is located above the crankshaft between the two banks of cylinders, where it is supported in five steel backed babbitt bearings. It is driven at $1/2$ crankshaft speed by sprockets and a single outside guide type chain.

V-6 engines are equipped with timing chain dampers as shown in Figure 2-7.

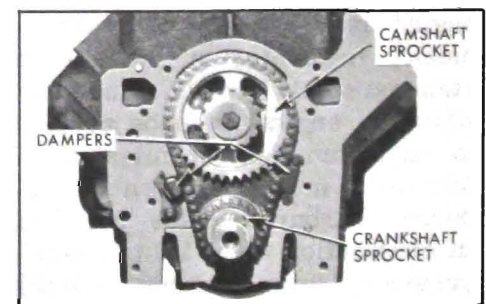

Figure 2-7—V-6 Timing Chain Installation

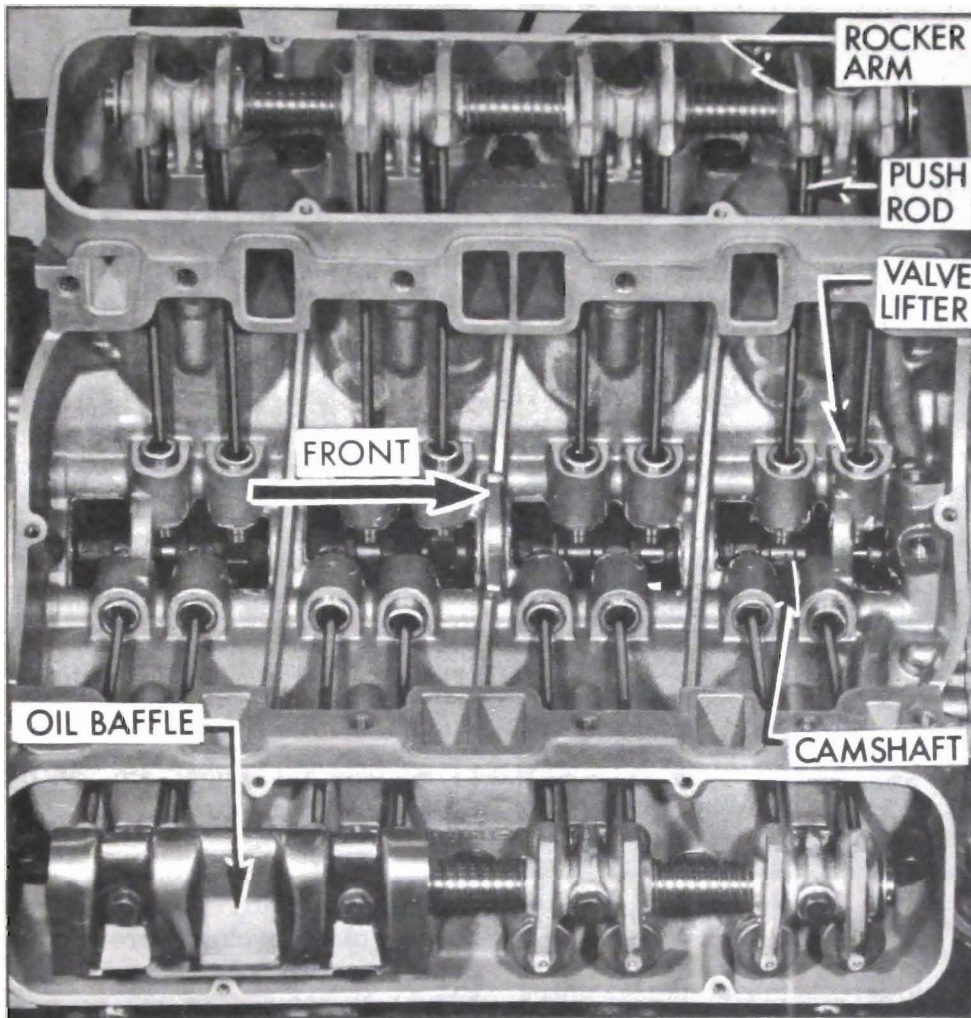

Figure 2-8—V-8 Valve Mechanism

Hydraulic valve lifters and one piece push rods are used to operate overhead rocker arms and valves of both banks of cylinders from a single camshaft. This system requires no lash adjustment at time of assembly or in service. Construction and operation of hydraulic valve lifters are described in subparagraph f below.

The rocker arms for each bank of cylinders are mounted on a tubular steel shaft supported on the cylinder head by die cast brackets.

The rocker arms are die cast aluminum with inserts at the push rod socket and the valve stem contact face.

Each valve has a spring of ample capacity to insure positive valve seating throughout the operating speed range of the engine.

Intake valve heads are 1.5" in diameter and exhaust valve heads are 1.3125" in diameter. The valve rocker arm mechanism is protected by a sheet metal cover which seats against a raised surface of the cylinder head and is gasketed to prevent oil leaks.

f. Hydraulic Valve Lifters

In addition to its normal function of a cam follower, each hydraulic valve lifter also serves as an automatic adjuster which maintains zero lash in the valve operating linkage under all operating conditions. By eliminating all

lash in the operating linkage and also providing a cushion of oil to absorb operating shocks, the hydraulic valve lifter promotes quiet valve operation. It also eliminates the need for periodic valve adjustment to compensate for wear of parts.

As shown in Figure 2-11, all parts of a hydraulic lifter are housed in the body, which is the cam follower. The body and the plunger are ground to very close limits, then a plunger is selectively fitted to each body to assure free movement with very little clearance. The push rod seat is free to move with the plunger in the body and, as its name implies, it provides a spherical seat to support the lower end of the push rod.

The plunger and seat are pressed toward the upper end of the lifter body by a coil spring which also holds a check ball retainer against the lower end of the plunger. When lifter is out of engine, a spring wire retainer holds all parts in the body. The ball retainer holds a spring loaded check ball in position over the lower end of a feed hole in the plunger. See Figure 2-11.

When the valve lifter is installed in the engine, the push rod holds the seat and plunger downward and clear of the plunger retainer at all times. The plunger spring then presses the lifter body down against the camshaft and presses the plunger and seat up against the push rod with an eight pound load, this is enough to take up all lash clearances between parts in the valve linkage without affecting positive seating of the valve.

Oil is fed to all lifters through galleries in the crankcase, as described in paragraph 2-6. Oil enters each lifter through grooves and oil holes in the lifter body and plunger, flows down into the chamber below the plunger

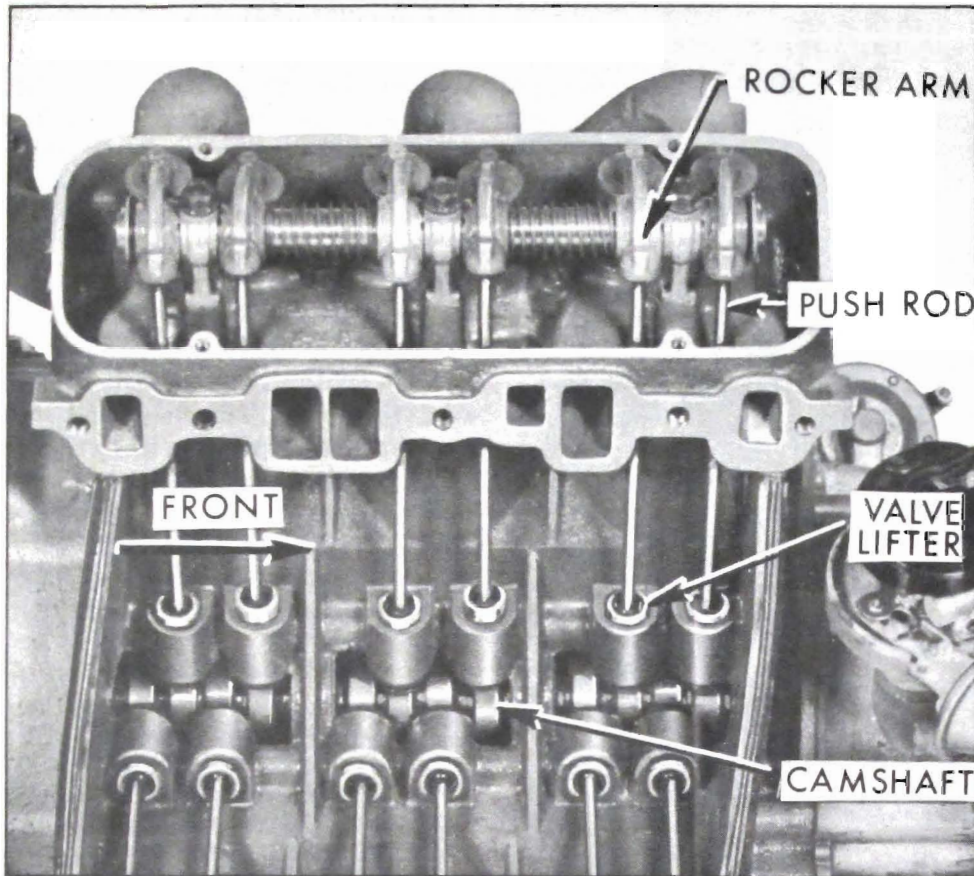

Figure 2-9—V-6 Valve Mechanism

through the feed hole and around the check ball. The first few cycles of operation after the engine is started forces out all air and completely fills the plunger and lower chamber of each lifter with oil.

At the start of a cycle of valve operation, the lifter body rests on the camshaft base circle. The plunger spring holds all lash clearances out of the valve linkage.

As the rotating camshaft starts raising valve lifter body, oil in

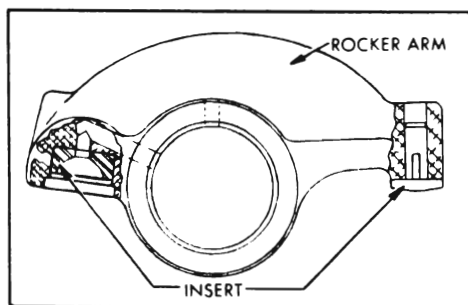

Figure 2-10—Valve Rocker Arm

the lower chamber and the check ball spring firmly seat the check ball against the plunger to prevent appreciable loss of oil from the lower chamber. The lifting force against the body is then transmitted through the entrapped oil to the check ball and plunger so that the plunger and push rod seat move upward with the body to operate the linkage which opens the engine valve.

As the camshaft rotates further to close the engine valve, the valve spring forces the linkage and lifter to follow the cam down. When the engine valve seats, the linkage parts and lifter plunger stop but the plunger spring forces the body to follow the cam downward .002" to .003" until it again rests on the camshaft base circle. Oil pressure against the check ball from the lower chamber ceases when the plunger stops and allows passage of oil past the check ball into the lower chamber

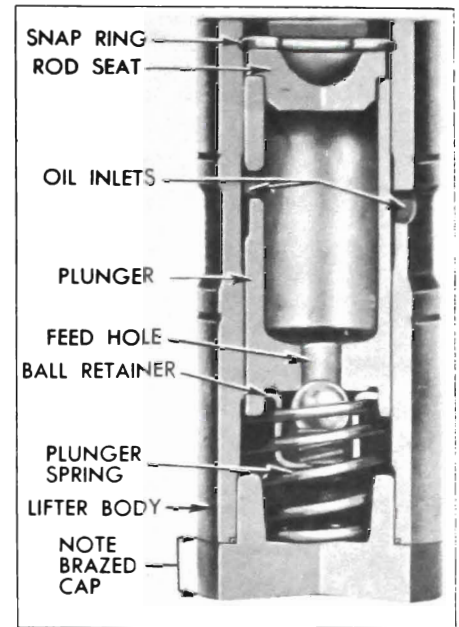

Figure 2-11—Hydraulic Valve Lifter, Sectional View

to replace the slight amount of oil lost by "leak-down".

During the valve opening and closing operation a very slight amount of oil escapes through the clearance between plunger and body and returns to the crankcase. This slight loss of oil (called "leak-down") is beneficial in providing a gradual change of oil in the lifter, since fresh oil enters the lower chamber when pressure is relieved on the check ball at the end of each cycle of operation.

When engine temperature increases and the valve linkage parts expand, the plunger must move to a slightly lower position in the lifter body to assure full closing of the engine valve. When engine temperature decreases and the linkage parts contract, the plunger must move to a slightly higher position in body to prevent lash clearances in the valve linkage. In either case, the capacity of the lower chamber changes and the volume of oil present is automatically controlled by passage of oil through the plunger feed hole.

2-6 ENGINE LUBRICATION SYSTEM

The engine lubrication system is the force feed type in which oil is supplied under pressure to the crankshaft, connecting rods, camshaft bearings and valve lifters. Oil is supplied under controlled volume to the rocker arm bearings and push rods. All other moving parts are lubricated by gravity flow or splash.

a. Oil Supply

The supply of oil is carried in the lower crankcase (oil pan) which is filled through a filler opening in the left rocker arm cover. The filler opening is covered by a combination filler and ventilating cap which contains a metal gauze to exclude dust. A removable oil gauge rod on the left side of the crankcase is provided to check oil level.

b. Oil Pump

The oil pump is located in the timing chain cover where it is connected by a drilled passage in the cylinder crankcase to an oil screen housing and pipe assembly. The screen is submerged in the oil supply and has ample area for all operating conditions. If the screen should become clogged for any reason, oil may be drawn into the system over the top edge of the screen which is held clear of the sheet metal screen housing.

Oil is drawn into the pump through the screen and pipe assembly and a drilled passage in the crankcase which connects to drilled passages in the timing chain cover. All oil is discharged from the pump to the oil pump cover assembly. The cover assembly consists of an oil pressure relief valve, an oil filter by-pass valve and a nipple for installation of an oil filter. The

spring loaded oil pressure relief valve limits the oil pressure to a maximum of 30 pounds per square inch. The oil filter by-pass valve opens when the filter has become clogged to the extent that 4 1/2 to 5 pounds pressure difference exists between the filter inlet and exhaust to by-pass the oil filter and channel unfiltered oil directly to the main oil galleries of the engine. See Figure 2-12.

c. Oil Filter

An AC full flow oil filter is externally mounted to the oil filter cover nipple on the right side of the engine just below the generator. Normally, all engine oil passes through the filter element, however, if the element becomes restricted, a spring loaded by-pass valve opens as mentioned in subparagraph b above.

d. Main Oil Galleries

The main oil galleries run the full length of the crankcase and cut into the valve lifter guide holes to supply oil at full pressure to the lifters. Connecting passages drilled in the crankcase permit delivery of oil at full pressure to all crankshaft and camshaft bearings.

e. Crankshaft, Connecting Rods and Pistons

Holes drilled in the crankshaft carry oil from the crankshaft bearings to the connecting rod bearings. Pistons and cylinder walls are lubricated by oil forced through a small notch in the bearing parting surface on the connecting rod, which registers with the hole in the crankpin once in

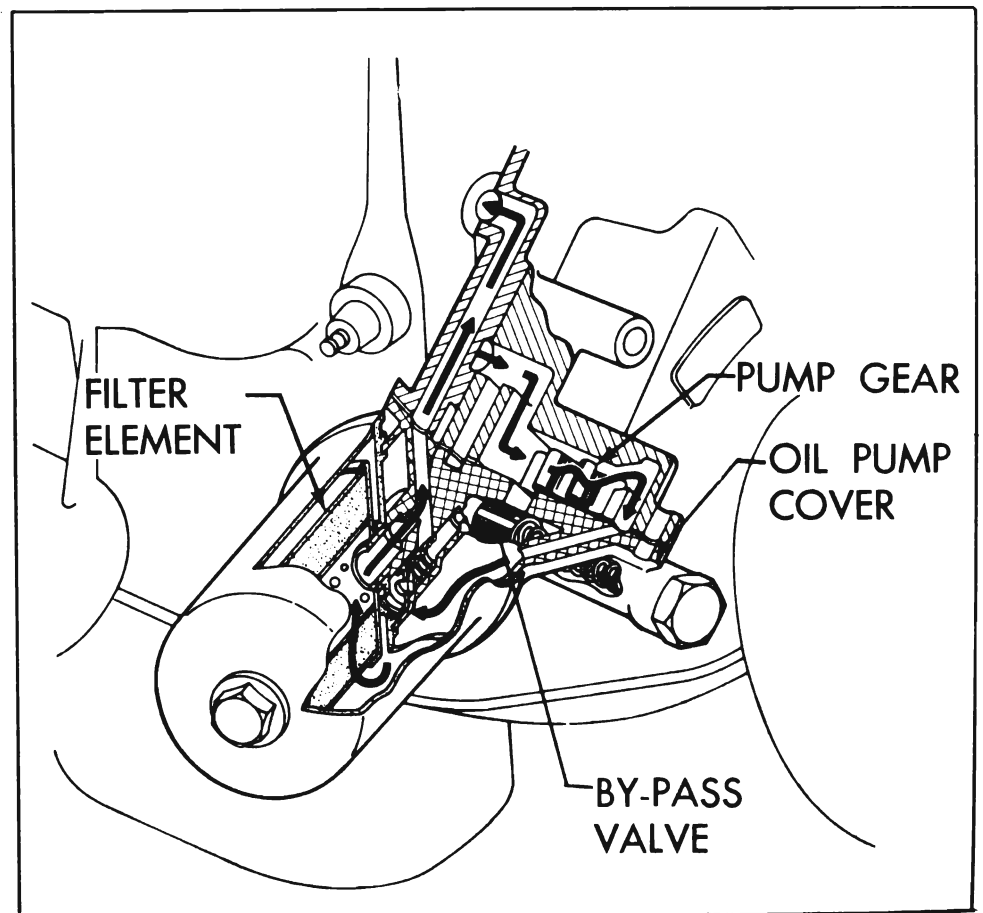

Figure 2-12—Oil Flow Through Filter

every revolution. Piston pins are lubricated by splash.

f. Timing Chain and Sprockets

Drilled holes in the camshaft connect the front camshaft bearing journal to the keyslot in the front of the camshaft. Oil flows from the journal into the keyslot over the woodruff key in the space between the key and the camshaft sprocket and fuel pump eccentric.

The forward end of the fuel pump eccentric incorporates a relief which allows the oil to escape between the fuel pump eccentric and the camshaft distributor gear. The oil stream strikes the distributor shaft gear once each camshaft revolution and provides ample lubrication of the timing chain and sprockets by splash.

g. Rocker Arms, Valves, and Push Rods

The rocker arms and valves on each cylinder head are supplied with oil from the oil galleries through holes drilled in the front of the cylinder block and cylinder head. The hole drilled in the cylinder head ends beneath the front rocker arm shaft bracket. A notch cast in the base of the rocker arm shaft bracket allows the oil to flow up inside the bracket in the space between the bracket and bolt to the hollow rocker arm shaft which is plugged at both ends. Each rocker arm receives oil through a hole in the under side of the shaft. Grooves

in the rocker arm provide lubrication of the bearing surface. Oil is metered to the push rod seat and valve stem through holes drilled in the rocker arm. Excess oil drains off and returns to the oil pan through passages in the cylinder head and block.

2-7 ENGINE COOLING SYSTEM

The engine cooling system is the pressure type with thermostatic control of coolant circulation.

The cooling system is sealed by a pressure type radiator filler cap which causes the system to operate at higher than atmospheric pressure. The higher pressure raises the boiling point of the coolant and increases the cooling efficiency of the radiator. The 15 pound pressure cap used raises the coolant

boiling approximately 38°F.

The pressure type radiator filler cap contains a blow off or pressure valve and a vacuum or atmospheric valve. See Figure 2-13. The pressure valve is held against its seat by a spring of predetermined strength which protects the radiator by relieving the pressure if the pressure should exceed that for which the radiator is designed.

The vacuum valve is held against its seat by a light spring which permits opening of the valve to relieve vacuum created when the system cools off.

The coolant is circulated by a centrifugal pump mounted on the timing chain cover which forms the outlet side of the pump. The engine fan and pulley(s) are bolted

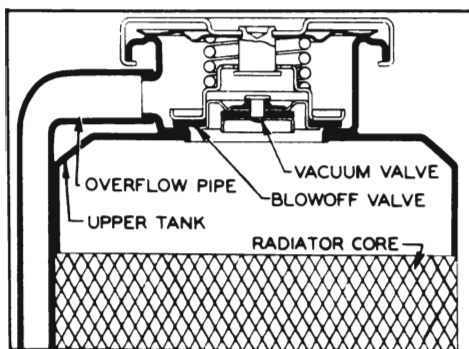

Figure 2-13—Radiator Cap

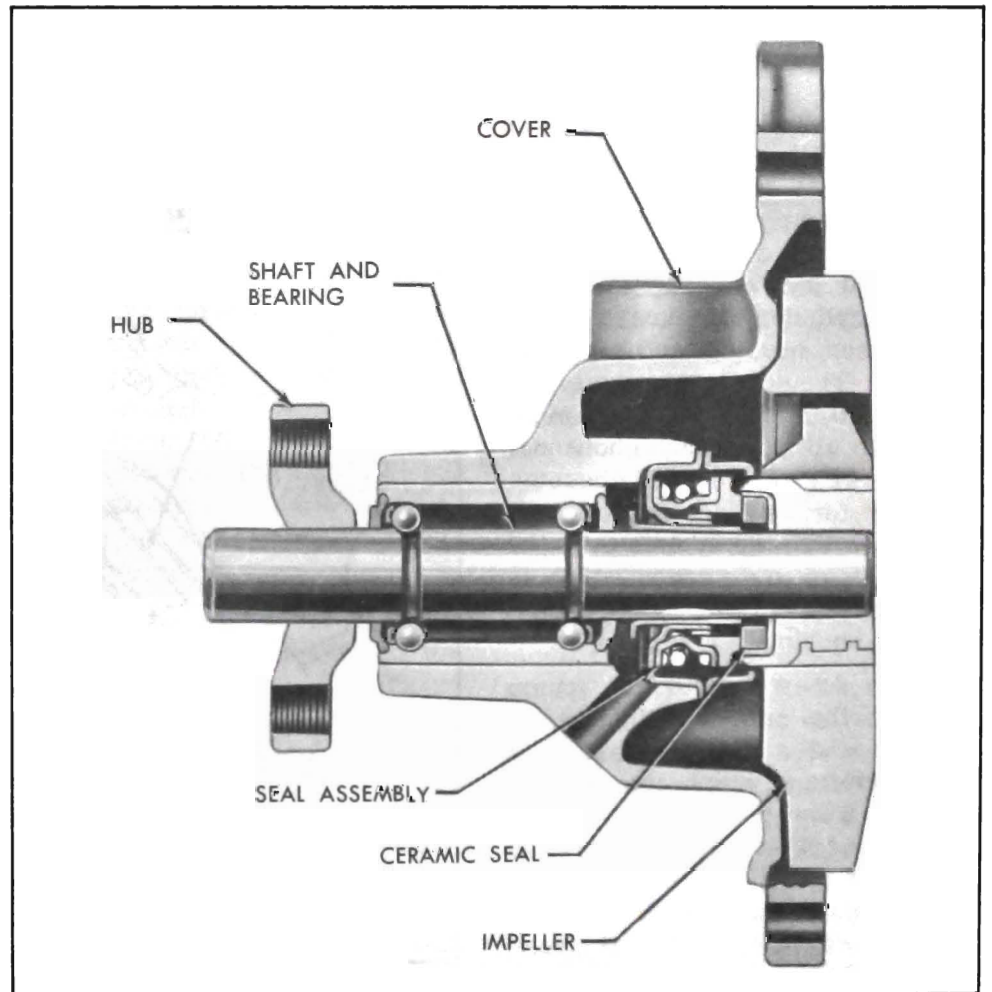

Figure 2-14—Water Pump

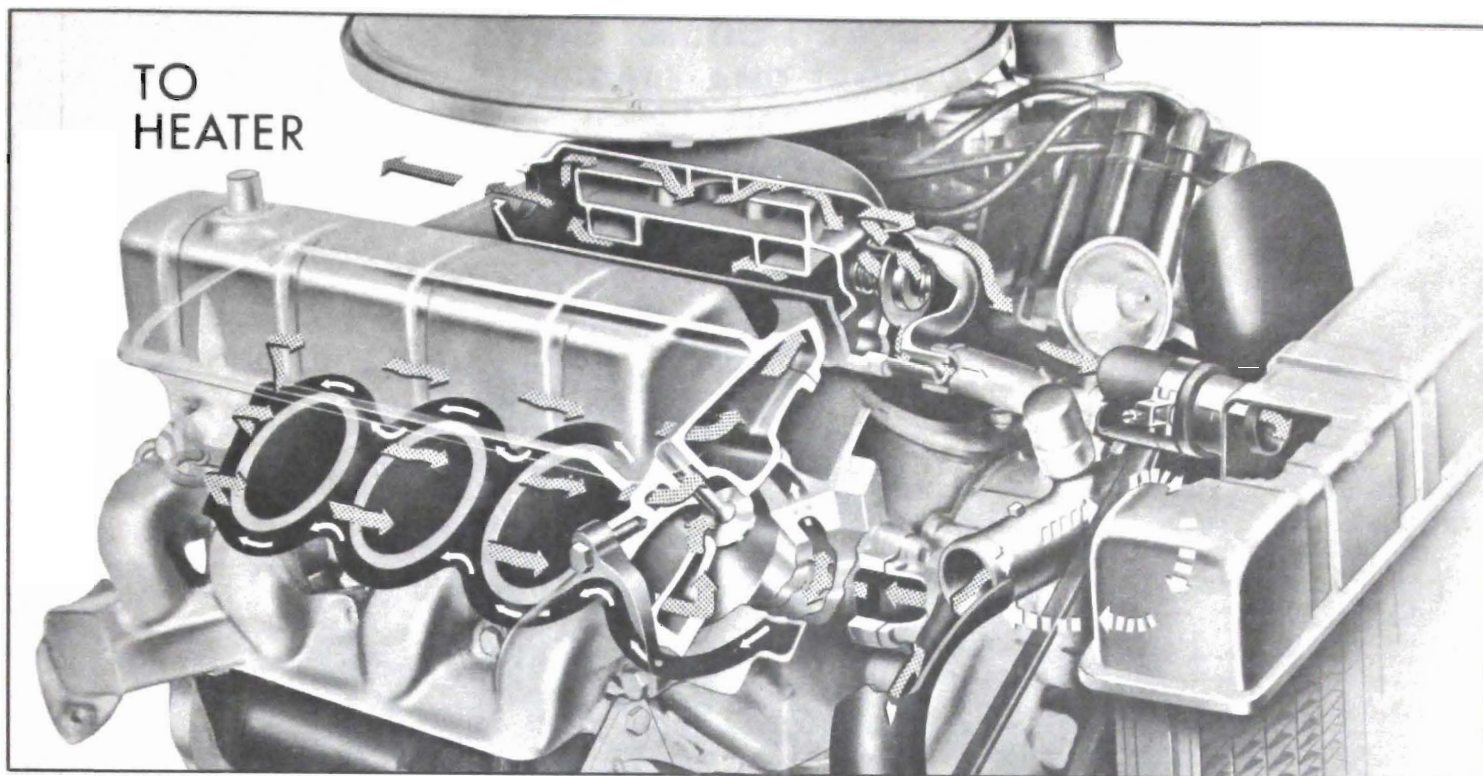

Figure 2-15—V-8 Engine Coolant Flow
cylinder bank water jacket. See
Figures 2-15 and 2-16.

to the pump shaft hub at its forward end. Thus both the fan and pump are belt driven by a crankshaft pulley bolted to the harmonic balancer. The pump shaft and bearing assembly is pressed in the aluminum water pump cover. The bearings are permanently lubricated during manufacture and sealed to prevent loss of lubricant and entry of dirt. The pump is sealed against coolant leakage by a packless non-adjustable seal assembly mounted on the pump cover in position to bear against the impeller hub. The inlet pipe cast in the pump cover feeds into the passage formed by the cover and the front face of the impeller, which is mounted on the bearing shaft with the vanes facing rearward. Coolant flows through the inlet passage to the low pressure area at the center where it then flows rearward through three openings in the impeller. Vanes on the rotating impeller cause the coolant to flow radially outward through two discharge passages cast in the timing chain cover. These passages deliver an equal quantity of coolant to each

The coolant then flows rearward through the water jacket which surrounds each cylinder barrel and extends below the lower limit of piston ring travel. After flowing the full length of the cylinder banks, the coolant flows up through openings to the rear of the cylinder bank into the cylinder heads. The coolant flows forward in the cylinder heads to cool the combustion chamber areas. At the forward end of the cylinder heads the coolant flows into the intake manifold.

To this point, coolant circulation in the V-6 and V-8 are identical. In the V-8 engine the coolant flows into the intake manifold water jacket from the forward port in the cylinder heads. The coolant flows to the rear in the lower portion of the intake manifold and then forward in the upper portion to the thermostat housing and thermostat by-pass. The flow of heated coolant through the intake manifold water jacket warms the manifold evenly to provide good

vaporization of the incoming fuel charge. A port in the rear of the manifold allows connection to the heater hose in heater equipped jobs. See Figure 2-15.

In the V-6 engine, the coolant flows into the intake manifold water passage from the forward port of the cylinder heads to the thermostat housing and thermostat by-pass. A nipple in the manifold allows connection of the heater hose in heater equipped jobs. See Figure 2-16.

A pellet type thermostat housed in the forward (outlet) end of the intake manifold controls the circulation of water through the engine radiator. During cold engine operation when the thermostat is closed, a thermostat by-pass, open at all times, allows recirculation of coolant through the engine to provide rapid warm-up. When the thermostat opens, coolant is directed to the upper tank of the radiator and thence through the radiator core, lower tank to water pump inlet where the cycle is repeated.

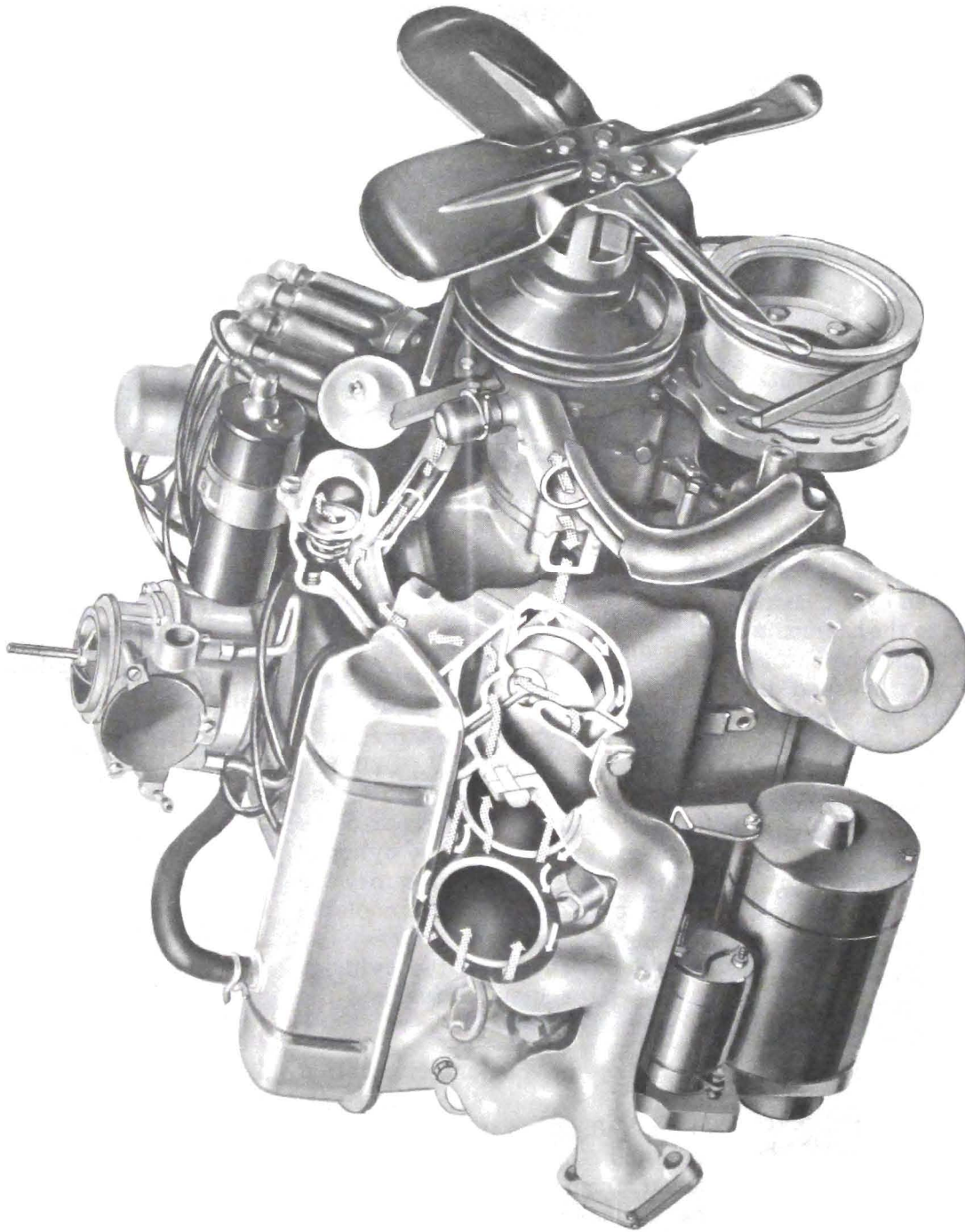

Figure 2-16—V-6 Engine Coolant Flow