

## SECTION 11-C OPTIONAL HEATER WITH AIR CONDITIONER

### CONTENTS OF SECTION 11-C

Paragraph	Subject	Page	Paragraph	Subject	Page
11-10	Specifications . . . . .	11-22	11-16	Description of Air Conditioning Components . . . . .	11-30
11-11	General Description of Heater-Air Conditioner System . . . . .	11-22	11-17	Service Procedures . . . . .	11-40
11-12	Description of Air Flow thru System	11-22	11-18	Servicing Refrigerant Charged Components . . . . .	11-42
11-13	Operation of Valve Controls . . . . .	11-26	11-19	Servicing Air Distribution Components . . . . .	11-70
11-14	Theory of Operation of Heater Portion of System . . . . .	11-28	11-20	Trouble Diagnosis . . . . .	11-73
11-15	Theory of Operation of Air Conditioner Portion of System . . . . .	11-29			

### 11-10 SPECIFICATIONS

#### a. Tightening Specifications

Part	Location	Torque Lb. Ft.
Nut	Hub of Clutch Drive Plate to Shaft and Swashplate Assembly . . . . .	14-16
Nut	Rear Head to Shell . . . . .	19-23

(For compressor mounting bracket bolts and nuts see figure 11-49)

#### b. Compressor Specifications

Type . . . . .	Six Cylinder Axial Opposed
Make . . . . .	Frigidaire
Effective Displacement (cu. in.) . . . . .	12.6
Oil . . . . .	Frigidaire 525 Viscosity
Internal Clearances . . . . .	See Figure 11-33
Oil Content (New) . . . . .	10 1/2 fl. oz.
Air gap between Clutch Drive Plate and Pulley . . . . .	0.022 to 0.057 inch
Clutch Type . . . . .	Magnetic
Belt Tension . . . . .	See Figure 11-116

### 11-11 GENERAL DESCRIPTION OF HEATER-AIR CONDITIONER SYSTEM

The heater-air conditioner is a series, custom type system in which the cooling unit and the heating unit are positioned in series with each other so that the air may be heated; dried and cooled; or dried, cooled and slightly reheated (muggy weather). The heating and air conditioning portions of the system are integral with each other. Doors are provided to afford custom regulation of temperature and humidity within the passenger compartment.

The following description of the heater-air conditioning system is divided into five areas: description of air flow through system, operation of door controls, theory of operation of heater portion of system, theory of operation of air conditioner portion of system, and description of air conditioning components.

### 11-12 DESCRIPTION OF AIR FLOW THRU SYSTEM

The following description for the flow of air in the heater-air conditioner system is divided into four groups: air flow for air conditioning, air flow for heating,

air flow for defrosting, and air flow for both air conditioning and heating.

#### a. Air Flow For Air Conditioning

During air conditioner operation the temperature control lever (see Figures 11-18 and 11-19) is set between COLD and halfway to MED positions. The air control lever is set at A/C position, and the FAN lever should be in low, medium or HI detents. Outside air enters the car through the air inlet grille and flows through the cowl air chamber and into the plenum blower and air door assembly. When the temperature

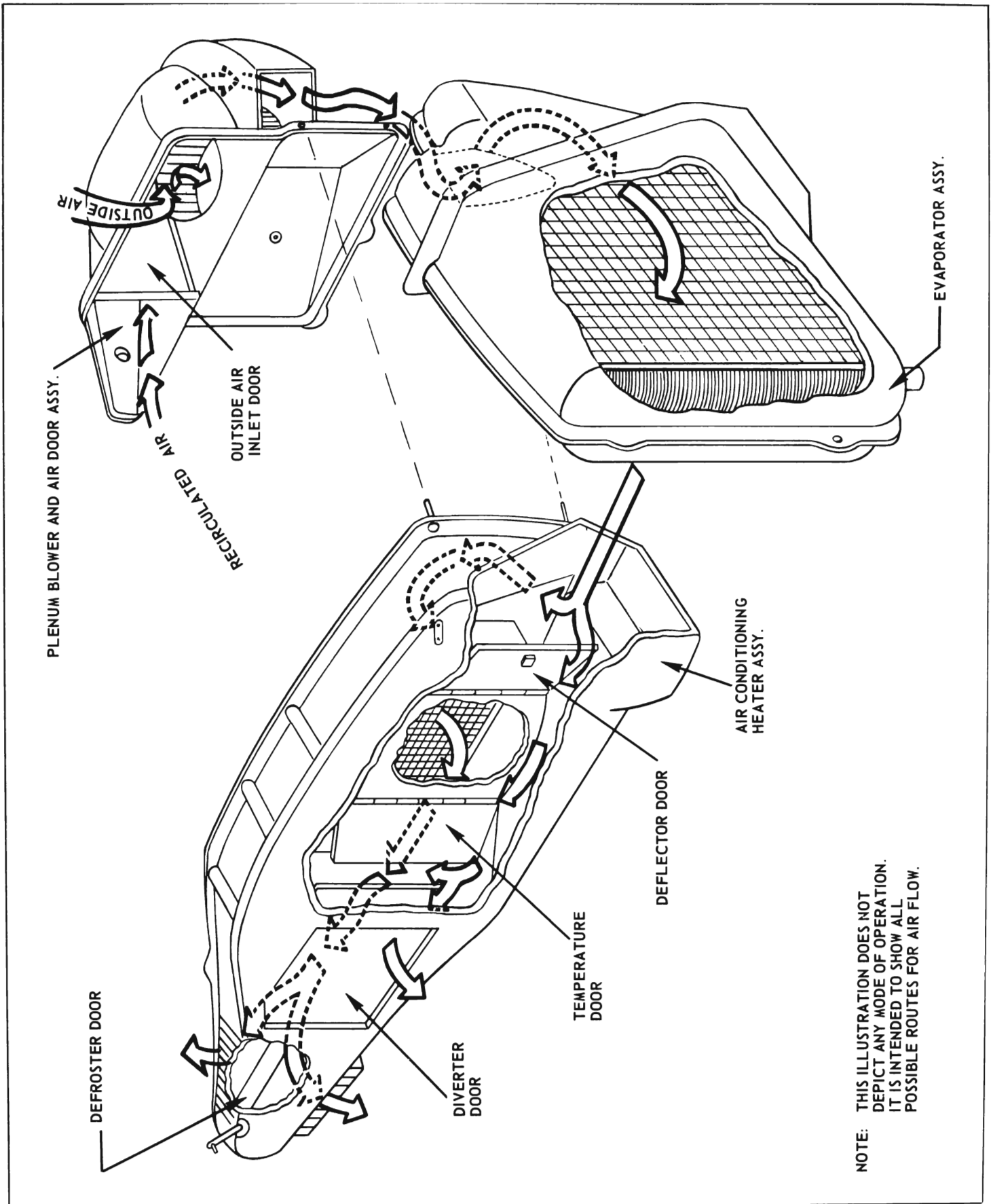

Figure 11-18—Air Flow Thru Heater-Air Conditioner System

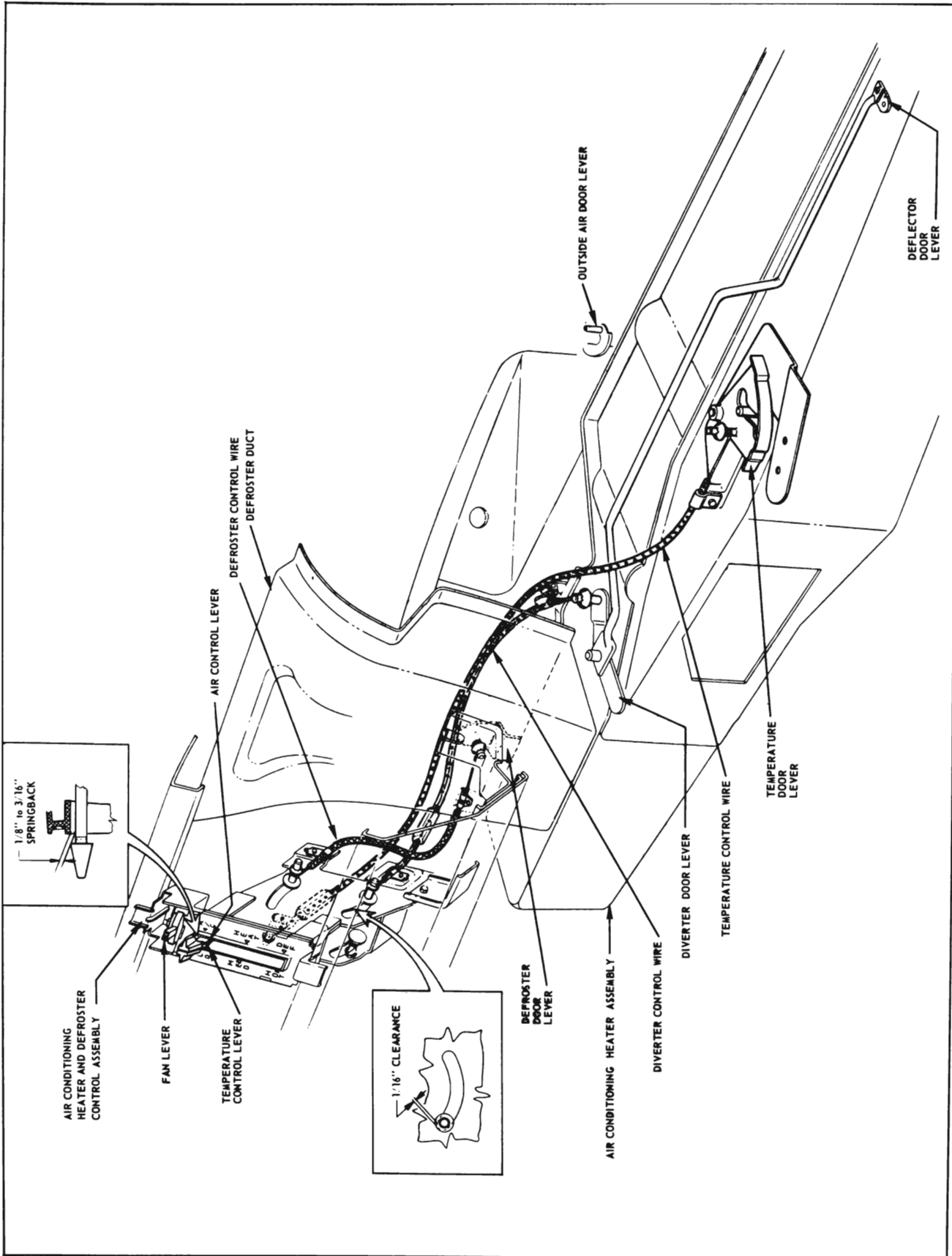

Figure 11-19—Air Conditioner Heater Assembly Control Wires and Controls

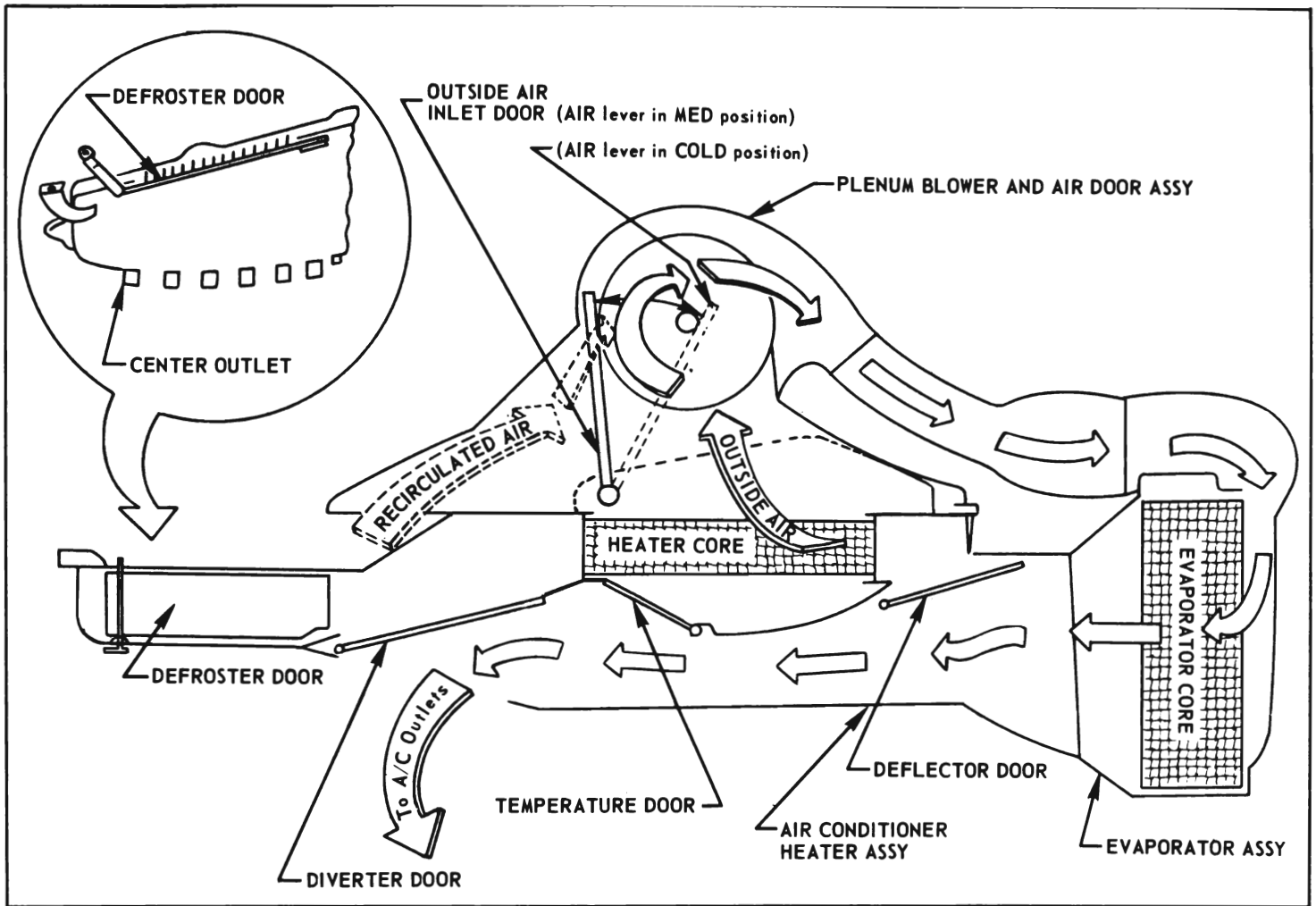

Figure 11-20—Air Flow for Air Conditioner Operation

lever is set at low, medium or HI detents the outside air inlet door partially opens (see Figure 11-20) and allows recirculated air from inside car to re-enter system and mix with outside air.

Positioning of the temperature lever to COLD provides maximum cooling of the passenger compartment. When the temperature lever is moved just past COLD position the outside air inlet door fully opens and blocks off all recirculated air flow. From the plenum blower and air door assembly the air is directed into the evaporator assembly. Movement of the air flow through the system is initiated by the blower motor switch. During air conditioner operation the air control lever is in A/C position and

the deflector door and the diverter door are positioned so that they will divert the air flow after it leaves the evaporator assembly to the air conditioner outlets.

**b. Air Flow For Heating**

During heater operation (temperature lever between MED and HOT position) the outside air inlet door will be fully open (see Figure 11-21) and only outside air will pass through the plenum blower and air door assembly. From the plenum blower and air door assembly the air is channeled through the inactive evaporator core and is directed into the air conditioner heater assembly. The deflector and diverter doors will be positioned as shown in Figure 11-21 when the

air lever is in HTR position. The air is diverted through the heater core as shown. The amount of air allowed to pass through the heater core is regulated by the temperature door. A small amount of unheated air is allowed to get past the deflector door. This unheated air will dilute the heated air depending on the opening of the temperature door. Maximum setting of the temperature lever to HOT position fully opens the temperature door and blocks off all unheated air by-passing the heater core. After the heated air leaves the heater core it passes thru the center outlet and into the front of the passenger compartment. Movement of the flow of air thru the system may be either forced air by use of the blower motor or ram air.

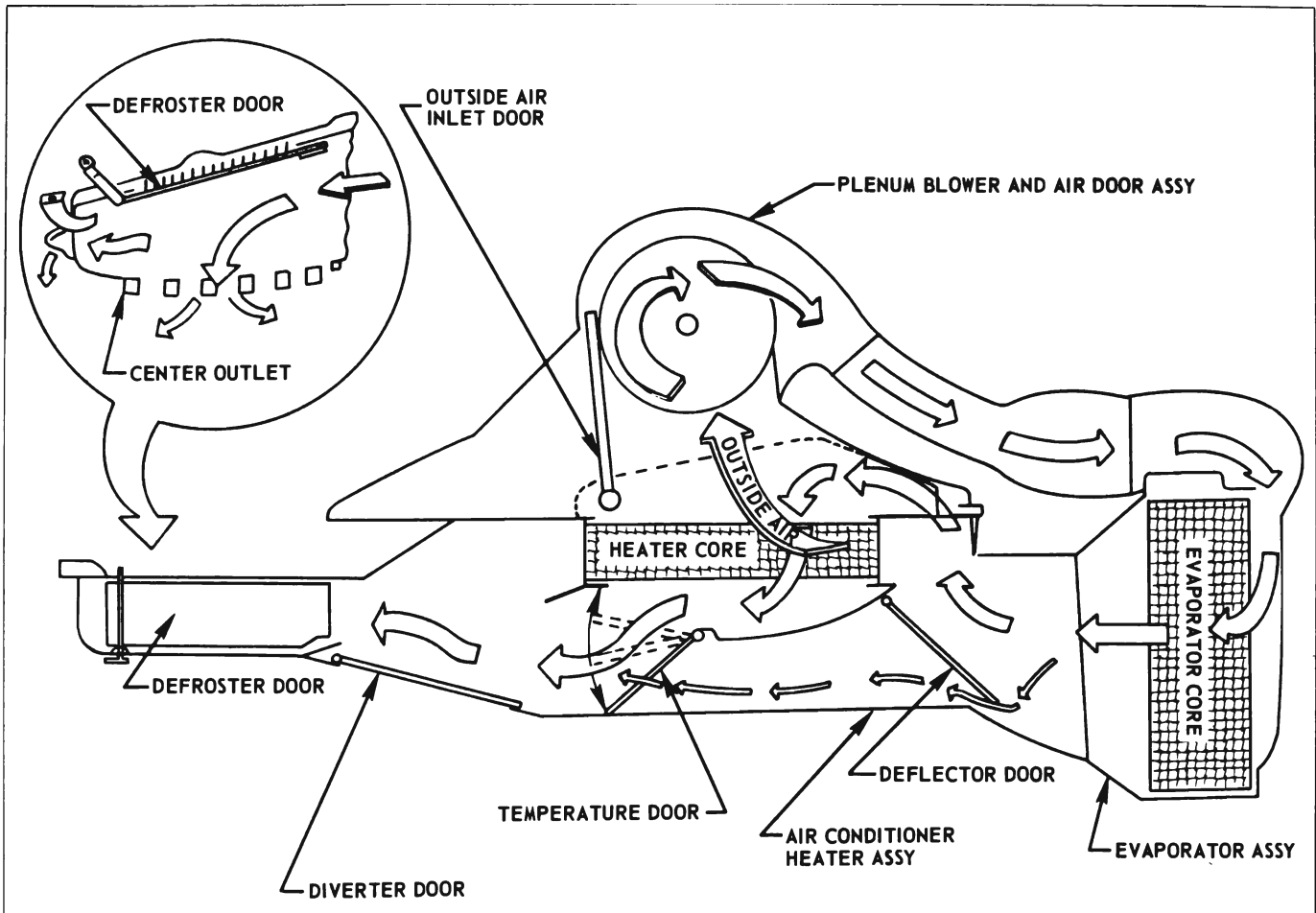

Figure 11-21—Air Flow for Heater Operation

### c. Air Flow For Defrosting

The air flow for defrosting is similar to air flow for heating, except that the defroster door is opened and air is routed to the defroster outlets. When the system is adjusted for defrosting (air control lever set at DEF position and temperature control lever set between MED and HOT positions) the doors will be positioned as shown in Figure 11-22. The balance of the air flow not diverted to the defroster outlets is channeled to the floor outlets.

### d. Air Flow For Both Air Conditioning and Heating

Outside air enters the car through the air inlet grille and flows

through the cowl air chamber and into the plenum blower and air door assembly (see Figure 11-23). Positioning of temperature control lever to between MED and HOT positions fully opens the outside air inlet door (blocking off recirculated air flow) and partially opens the temperature door. The air flows from the plenum blower and air door assembly to the evaporator assembly. The now cooled air flows from the evaporator assembly to the air conditioner heater assembly. Most of the air flow is diverted by the deflector and diverter doors to bypass the heater core. A small portion of the air flow is allowed to get past the deflector door and flow through the heater core. Both the heated and the air conditioned

air mix together and are channeled to the air conditioner outlets. The air flow under these conditions is dehumidified and slightly warmed, and is particularly suited to provide comfortable driving conditions during muggy weather.

## 11-13 OPERATION OF DOOR CONTROLS

All the controls for regulation of the heater—air conditioner system are located on the air conditioning heater and defroster control assembly. They are as follows:

### a. Temperature Control Lever (Fig. 11-19)

The temperature control lever regulates the outside air inlet

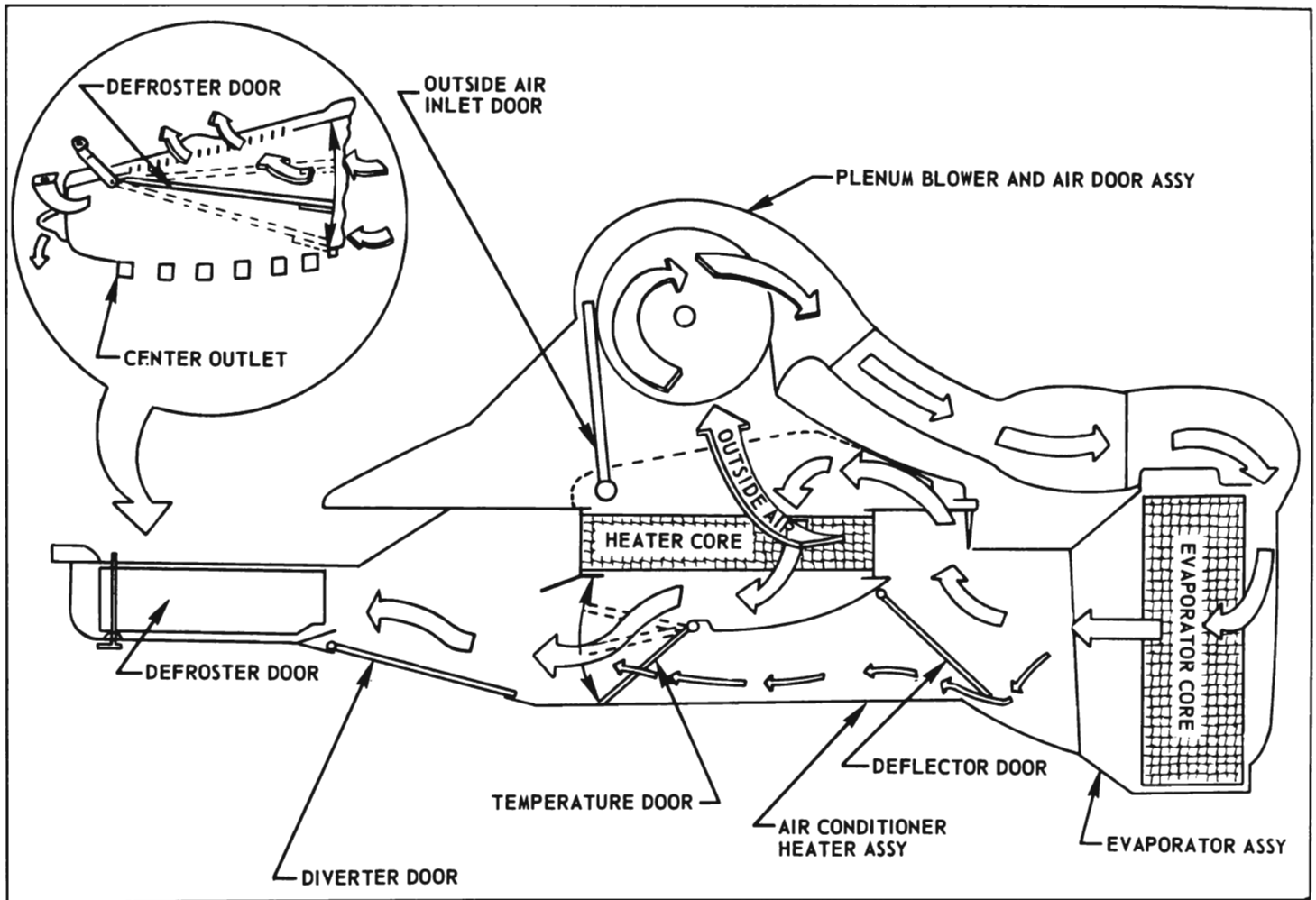

Figure 11-22—Air Flow for Defroster Operation

door, the temperature door, the vacuum operated water valve, and the vacuum diaphragm of the suction throttling valve. When the temperature control lever is in COLD position, the temperature door and the vacuum operated water valve are closed. Movement of the temperature control lever slightly past COLD position to MED position performs three successive system changes which have the effect of gradually increasing the temperature of the air conditioned air. As the lever is moved toward MED positions, first the outside air inlet door is fully opened cutting off recirculated air flow from inside car. Thus, only outside air is used, and the pre-cooled air circulation is cut-off. Next, vacuum is removed from the vacuum diaphragm of the suction throttling

valve (provided FAN lever on), and the result is that the evaporator operates at a higher pressure—hence decreased cooling. Thirdly, vacuum is applied to the vacuum element of the water valve, thereby allowing circulation through the heater core. This results in a further increase of the temperature of the air conditioned air. As the temperature lever is moved from MED to HOT positions the temperature door is proportionately opened and more air is forced to circulate around the heater core.

**b. Air Control Lever (Fig. 11-19)**

The air control lever regulates the position of the diverter door,

deflector door, defroster door, and also operates one of the three electrical switches (air conditioner clutch compressor switch) in the air conditioner circuit. When the air control lever is in A/C position the diverter and deflector doors divert most of the air flow and cause it to bypass the heater core. In addition, when the air control lever is in A/C position, a pin on the lever holds the air conditioner clutch compressor switch closed. This switch is one of three switches (see Figure 11-24) in the heater-air conditioner circuit which must be closed to operate the compressor. Movement of the air control lever to HTR position changes the angle of the diverter and deflector doors, and diverts most of the air flow through the heater core. Also, when the air control lever

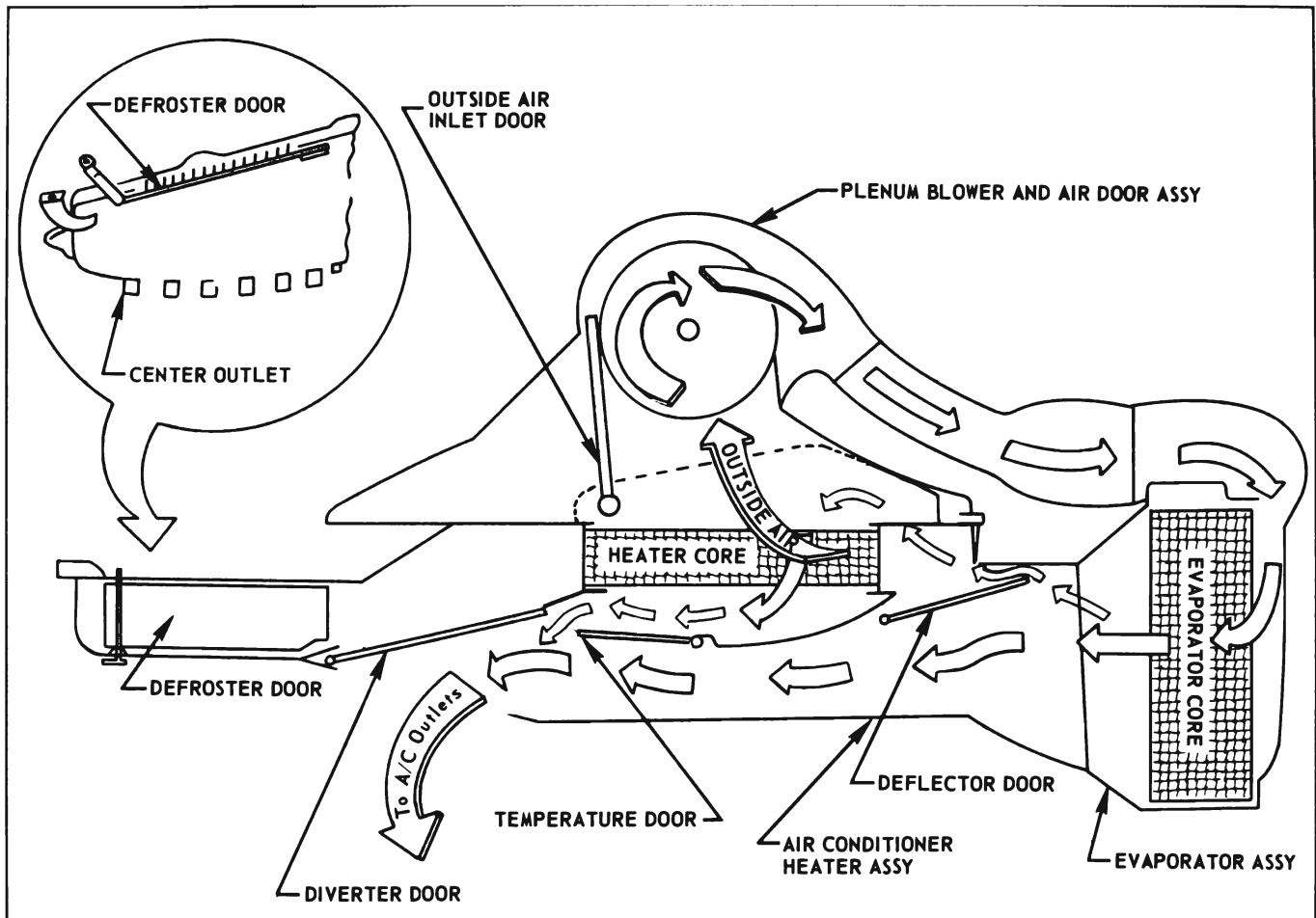

Figure 11-23—Air Flow for both Air Conditioner and Heater Operation

is in HTR position the air conditioner clutch compressor switch is allowed to open and break the circuit for air conditioner operation. Further movement of the air control lever to DEF position opens the defroster door and diverts air flow from floor outlets to defroster outlets. Midway location of air lever between HTR and DEF positions will apportion the air flow to both the defroster and floor outlets.

#### c. Fan Control Lever (Fig. 11-19)

The fan control lever operates the heater blower switch and applies vacuum to the vacuum diaphragms of the outside air inlet

door and suction throttling valve. When the lever is moved to low position (1st detent) four changes take place in the system, provided the air control lever is in A/C position. First, the blower motor is actuated and air is force fed through the system. Secondly, the magnetic clutch of the compressor is actuated and air conditioning system is in turn actuated. Thirdly, the vacuum is applied to the vacuum diaphragm of the suction throttling valve (provided the temperature control lever is in COLD position) and the evaporator operates at maximum cooling. Fourthly, a vacuum is applied to the dual stage diaphragm of the outside air inlet door and the door partially opens permitting outside

and recirculated air flow through system. Further movement of the FAN lever to medium or HI positions (2nd and 3rd detents) proportionately increases the blower speeds.

The FAN lever only operates the blower motor when the air control lever is in HTR or DEF positions.

#### 11-14 THEORY OF OPERATION OF HEATER PORTION OF SYSTEM

Engine heat is transmitted to the heater core by the flow of coolant through the core. The flow of coolant or water through the

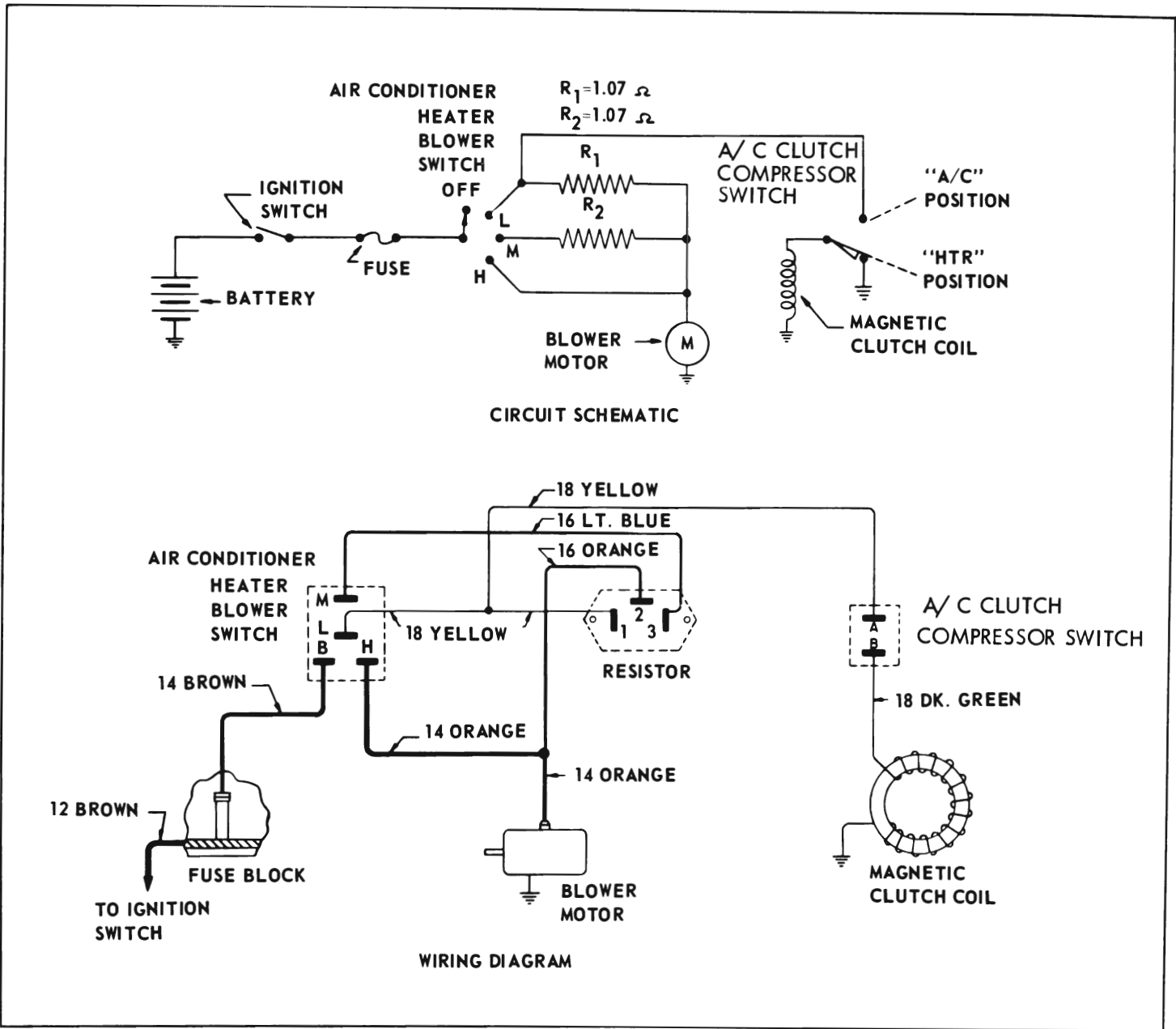

Figure 11-24—Circuit Schematic and Wiring Diagram of Heater Air Conditioner System

heater core of the heater—air conditioner system is as shown in Figures 11-25 and 11-26. Coolant or water enters the lower port of the heater core and exits from the upper port. The flow of coolant (hence operation of the heater core) is turned on and off by means of the water valve. The valve is vacuum operated and is actuated by a vacuum disc switch located on the heater and defroster control assembly. The

water valve is closed when the temperature control lever is between the COLD and MED positions. The valve is fully opened whenever the temperature control lever is moved slightly past the MED position, and will stay fully open for the remainder of the travel of the temperature control lever to HOT position. A 180° thermostat is provided as standard equipment on both V-6 and V-8 engines.

### 11-15 THEORY OF OPERATION OF AIR CONDITIONER PORTION OF SYSTEM

The state of the refrigerant at the inlet port of the compressor is a low pressure gas. The compressor compresses the gas into a high pressure high temperature gas (see Figure 11-27). Because of the increase in pressure, the



heat in the gas has been concentrated and therefore is increased above the ambient (outside air) temperature. This heat in excess above the ambient temperature tends to dissipate itself. A condenser is utilized in the circuit to provide a means whereby the heat of the refrigerant can be easily dissipated. The high pressure, high temperature (hot) gas flows through the condenser and is cooled to a high pressure liquid as it gives up its heat. From the condenser the high pressure liquid flows to the receiver-dehydrator and then to the expansion valve where the pressure is reduced and the liquid is allowed to expand in the evaporator. When the pressure is reduced the refrigerant will successively transform itself from a high pressure liquid to a low pressure liquid, and then to a low pressure gas. As the low pressure liquid expands and becomes a low pressure gas it absorbs heat. To satisfy the refrigerant demand for heat, the air passing over the evaporator gives up heat to the evaporator and in doing so, it as a result is cooled.

The low pressure gas returns to the inlet port of the compressor (the original starting point) where the cycle just described repeats itself. Although the foregoing description holds true in actual system operation, it should be qualified insofar as whenever the compressor is running, there is a continuous liquid flow of refrigerant and oil throughout the system.

**11-16 DESCRIPTION OF AIR CONDITIONING COMPONENTS**

**a. Compressor**

The compressor is located on right side of the engine compartment (see Figure 11-28). The purpose of the unit is to draw the low pressure vapor from the

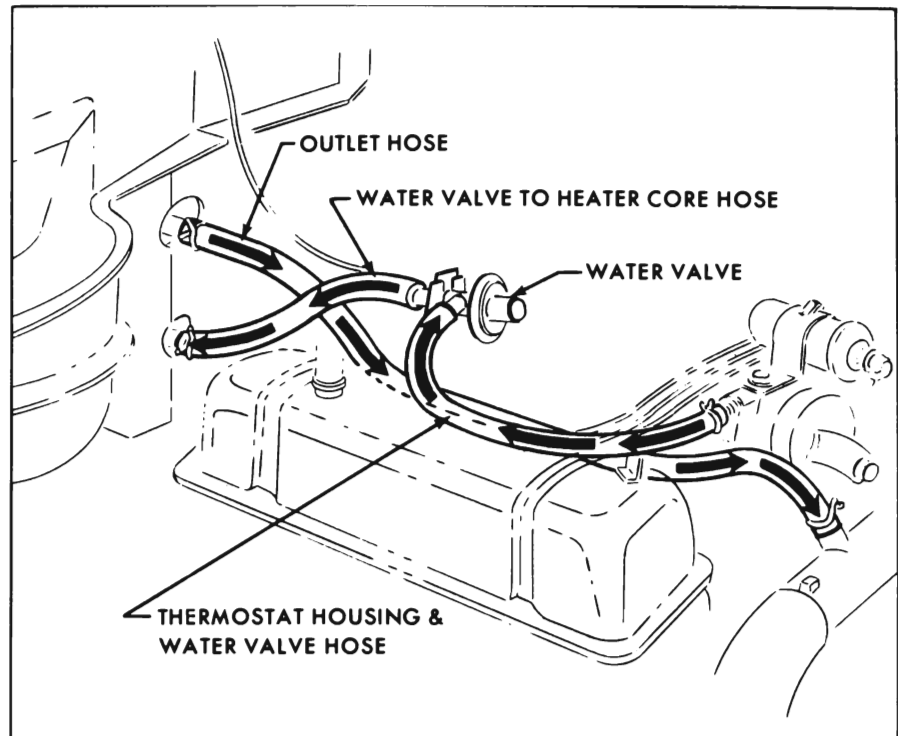

Figure 11-25—Heater Coolant Circulation - V-6 Engine

evaporator and compress this vapor into a high temperature and high pressure gas. This action will result in the refrigerant having a higher temperature than the surrounding air.

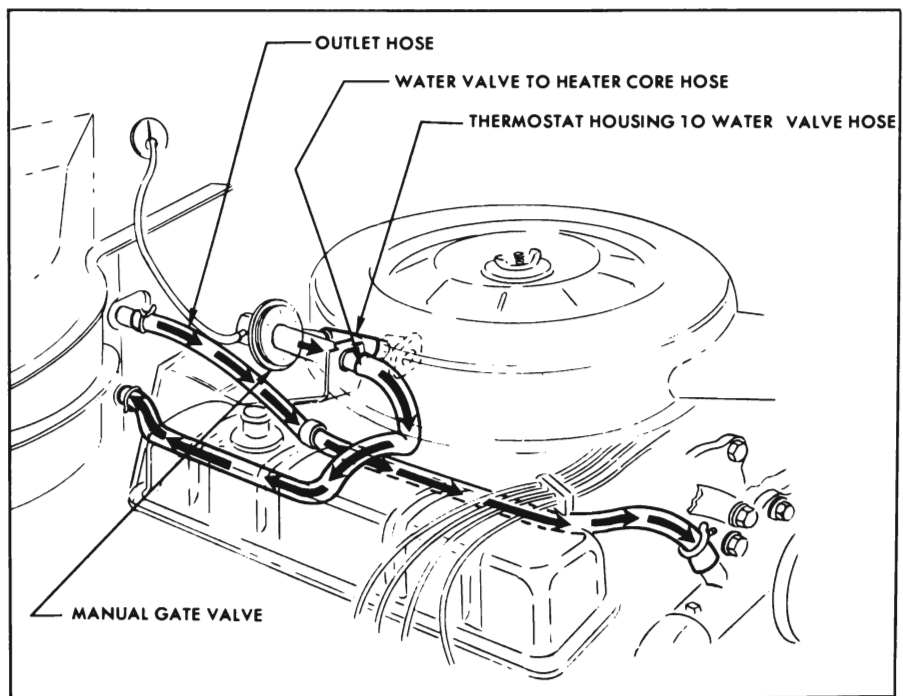

Figure 11-26—Heater Coolant Circulation - V-8 Engine

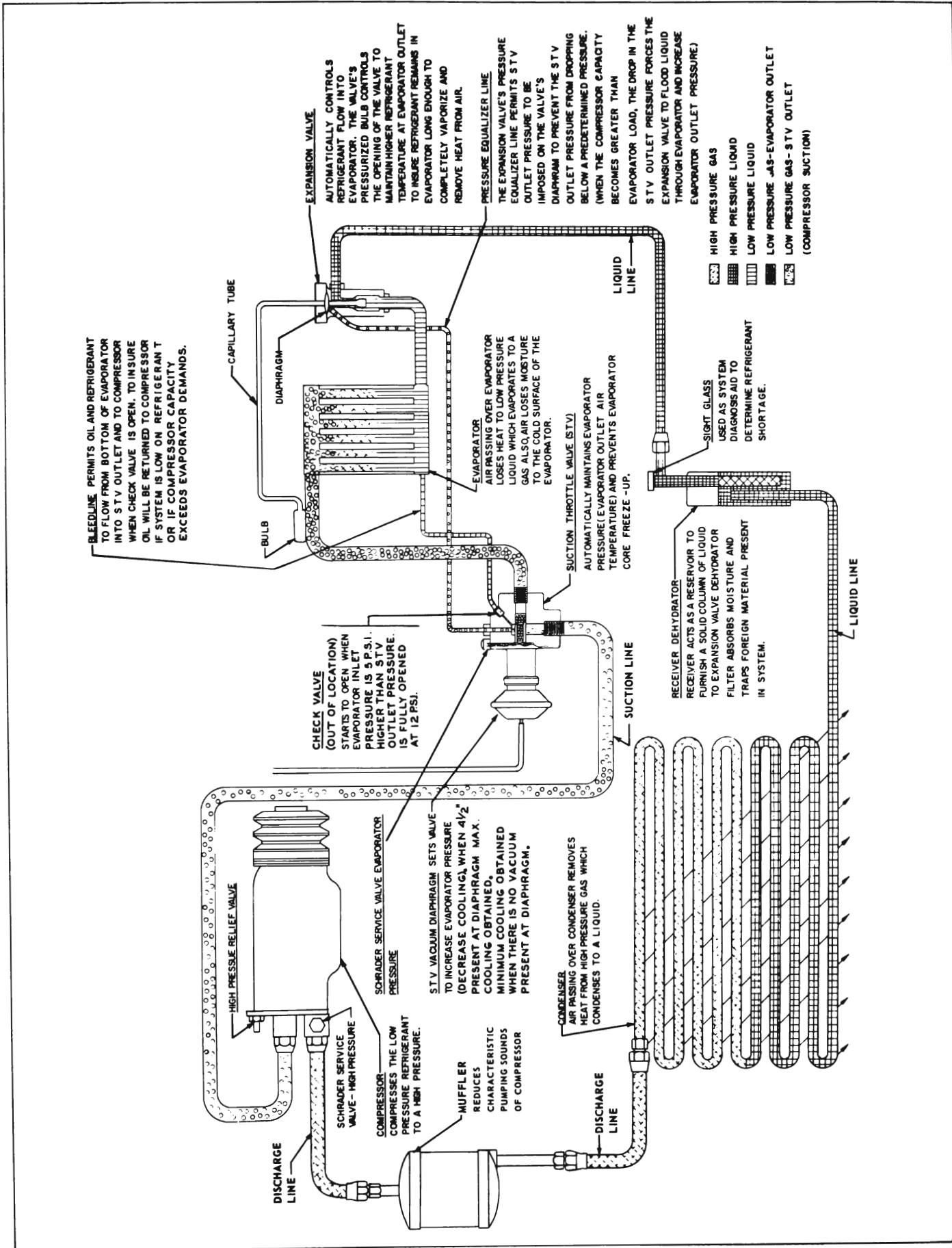

Figure 11-27—Air Conditioner Refrigeration Circuit

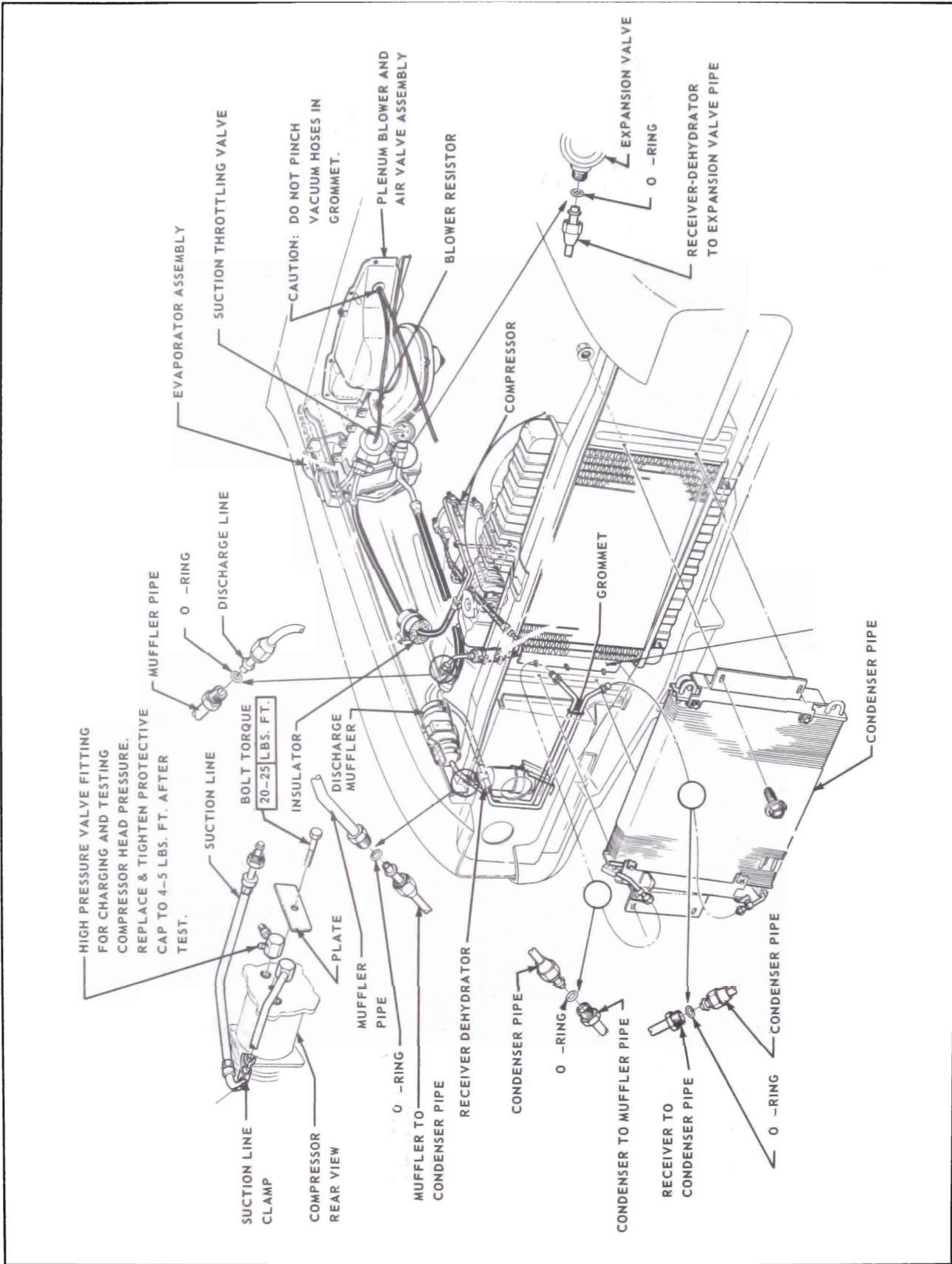

Figure 11-28—Air Conditioner Refrigeration Components Installation

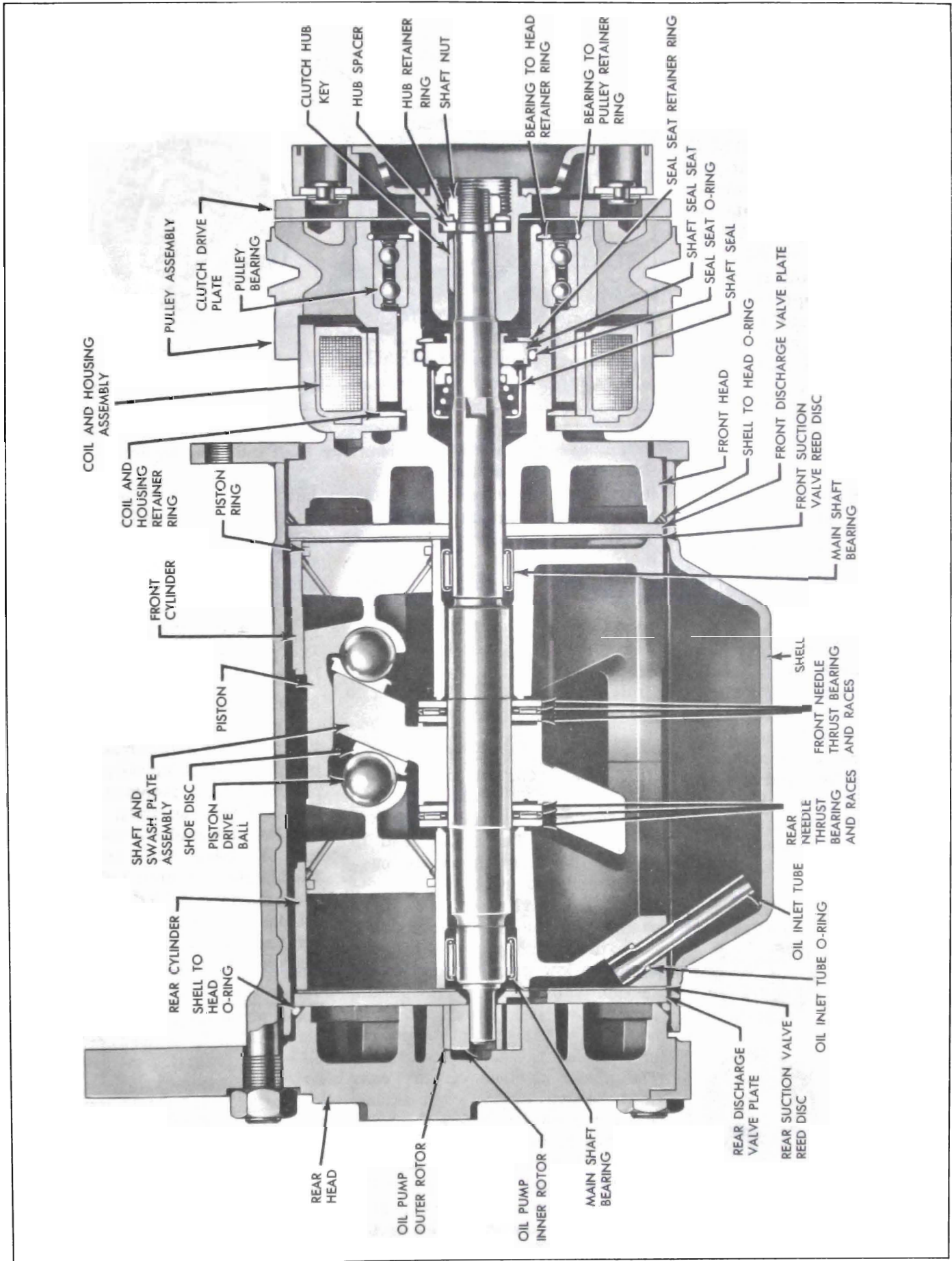

Figure 11-29—Compressor (Sectional View)

The compressor is of basic double action piston design. Three horizontal double acting pistons make up a six cylinder compressor (see Figure 11-29). The pistons operate in 1-1/2 inch bore and have a 1-1/8 inch stroke. A swash plate keyed to the shaft drives the pistons. The shaft is belt driven through a magnetic clutch and pulley arrangement. An oil pump mounted at the rear of the compressor picks up oil from the bottom of the compressor and lubricates the bearings and other internal parts of the compressor. Reed type valves at each end of the compressor open or close to control the flow of incoming and outgoing refrigerant. Two gas tight passages interconnect chambers of the front and rear heads so that there is one common suction port, and one common discharge port.

1. Suction Valve Reed Discs and Discharge Valve Plates—The two suction valve reed discs and two discharge valve plates (see Figure 11-30) operate in a similar but opposite manner. The discs are composed of three reeds and function to open when the pistons are on the intake portion of their stroke (downstroke), and close on the compression stroke. The reeds allow low pressure gas to enter the cylinder heads. The discharge valve plates also have

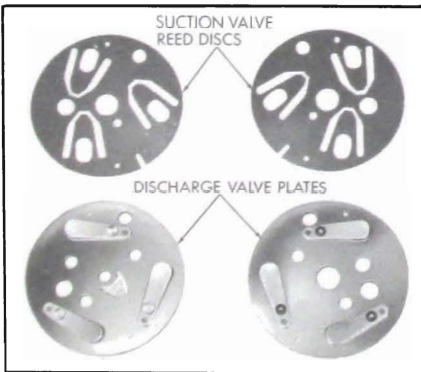

Figure 11-30—Compressor Suction Valve Reed Discs and Discharge Valve Plates

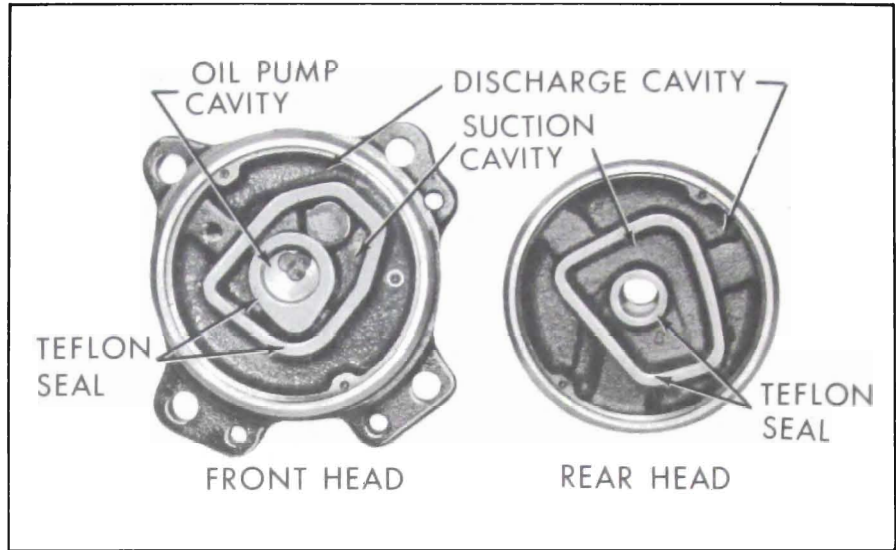

Figure 11-31—Compressor Front and Rear Heads

three reeds, however, they function to open when the pistons are on the compression portion of their stroke (upstroke), and close on the intake stroke. High pressure gas exits from the cylinder head discharge port. Three retainers riveted directly above the reeds on the valve plate serve to limit the opening of the reeds on the compression stroke.

2. Front and Rear Heads—The front and rear heads (Figure 11-31) serve to channel the refrigerant into and out of the cylinder heads. The front head is divided into two separate passages and the rear head is divided into three separate passages. The outer passage on both the front and rear heads channels low pressure gas to the suction valve reeds. The middle passage on both front and rear heads channels high pressure gas to the discharge valve plate reeds. The inner passage on the rear head houses the oil pump inner and outer rotors. A teflon sealing material is bonded to the sealing edges separating the passages in the front and rear head. "O" rings are used to affect a seal between the mating edges of the heads and the shell. The front

head suction and discharge passages are connected to the suction and discharge passages of the rear head by a discharge tube and suction passage in the body of the cylinder assembly. A screen located in the suction port of the rear head prevents foreign material from entering the circuit.

3. Oil Pump—An internal tooth outer rotor and external tooth inner rotor comprise the oil pump. The pump works on the principle of a rotary type pump. Oil is drawn up from oil reservoir in underside of shell through the oil inlet tube (see Figure 11-32) and circulated through the system via a 3/16 inch diameter oil passage through the shaft center and also four 5/64 inch diameter holes drilled perpendicular

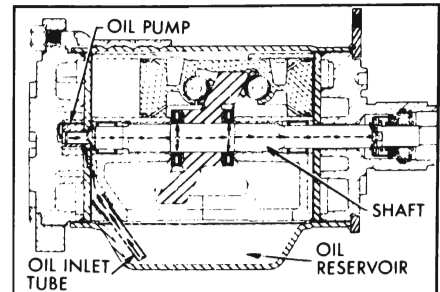

Figure 11-32—Compressor Oil Flow

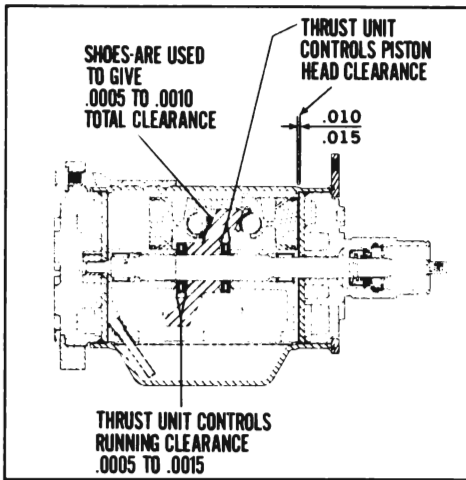

Figure 11-33—Compressor Needle Thrust Bearings and Races

to the shaft. The inner rotor is driven by the shaft.

4. Shaft and Swash Plate Assembly—The shaft and swash plate assembly (see Figure 11-29) consists of an elliptical plate positioned obliquely to the shaft. As the plate rotates on the shaft, the surface of the plate moves to and fro lengthwise relative to the centerline of the shaft. This reciprocating motion is transmitted to the pistons which contact the surface of the swash plate. A woodruff key locks the swash plate onto the shaft. The swash plate and shaft are serviced as an assembly. The shaft is driven by a pulley when the magnetic clutch is energized. A needle thrust bearing and a mainshaft bearing support the shaft horizontally and vertically.

5. Needle Thrust Bearing and Races—Two needle thrust bearings, each “sandwiched” between two races are located on either side of the swash plate hub. The front needle thrust bearing and races provide 0.010” to 0.015” clearance between the top of the pistons and the rear side of the front suction valve reed disc (see Figure 11-33). The rear needle thrust bearings and races provide 0.0005” to 0.0015” clearance between the hub of the swash plate

and the rear hub of the rear cylinder. Races of various thicknesses are provided for service replacement to achieve required clearances when rebuilding units.

6. Cylinder Assembly and Pistons—The cylinder assembly (front cylinder and rear cylinder) is serviced only as a matched set. Alignment of the two halves is maintained by two dowel (locator) pins.

The double ended pistons are made of cast aluminum. There are two grooves on each end of the piston. The outer grooves will receive a piston ring. The inner grooves act as oil scraper grooves to collect any excess oil. Two oil return holes are drilled into the scraper grooves and allow oil to drain back into the reservoir.

7. Shoe Discs—The shoe discs are made of bronze and act as a bearing between the ball and the swash plate. An oil circulation hole is provided through the center of each shoe for lubrication purposes. These shoes are provided in 0.0005 inch increments and ten sizes are available for service replacement. A basic “zero” shoe size is available for preliminary gauging procedures when rebuilding a cylinder assembly.

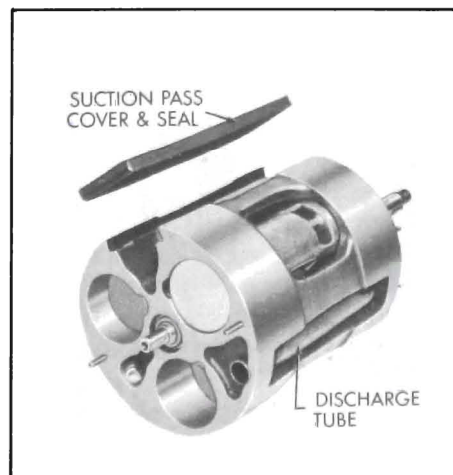

Figure 11-34—Suction Passage and Discharge Tube

8. Suction Pass Cover—The suction pass cover fits over a suction passage (see Figure 11-34) in the body at the cylinder assembly. A rectangular neoprene seal is used to insure proper sealing action along the edges of the cover. Low pressure vapor flows from the suction port through the suction passage in the cylinder assembly, and into the suction cavity of the front head.

9. Discharge Tube—The discharge tube is used to connect the discharge cavity in the front head with the discharge port in the rear head. High pressure vapor discharge is channeled via the tube to discharge port. A slightly modified discharge tube is provided to be used as a service replacement tube (see Figure 11-35). The service replacement tube has a reduced end and a built up shoulder to accommodate an “O” ring and bushing. These added parts achieve the necessary sealing of the high pressure vapor within the compressor.

10. Pressure Relief Valve—The purpose of the pressure relief valve is to prevent the discharge pressure from exceeding 440 psi.

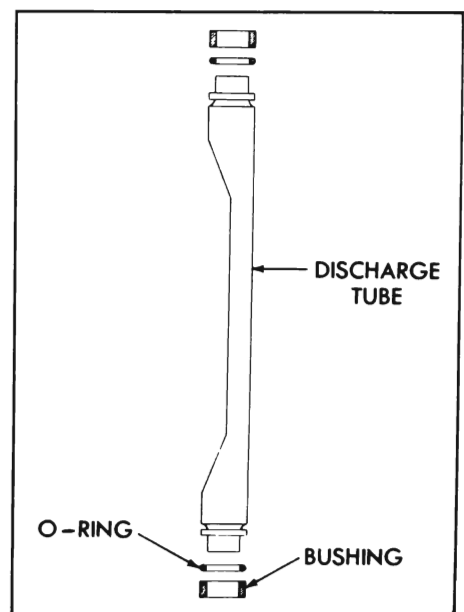

Figure 11-35—Service Replacement Discharge Tube

Opening of the pressure relief valve will be accompanied by a loud popping noise and perhaps the ejection of some refrigerant from the valve. If the pressure relief valve is actuated due to excessive pressures in the compressor, the cause of the malfunction should be corrected immediately. The pressure relief valve is located on the rear head of the compressor.

**11. Shell and Oil Drain Screw—**The shell of the compressor contains a reservoir which furnishes a continuous supply of oil to the moving parts of the compressor. A baffle plate covers the reservoir and is tack-welded to the inside of the shell. In addition an oil drain screw and gasket are located on the side of the reservoir and are provided for draining or adding of oil to system. To add oil, compressor must be removed from system. The necessity to add oil should only be required when the system has ruptured violently and oil has been lost along with refrigerant. Under controlled conditions or slow leak conditions it is possible to lose

only a small amount of oil with the refrigerant gas. The serial number, part or model number, and rating of the compressor is stamped on name plates located on top of shell. This information should be included on all reports, claims, and correspondence covering the unit.

**12. Magnetic Clutch and Pulley Assembly—**The magnetic clutch and pulley assembly (see Figure 11-36) together transmit power from the engine crankshaft to the compressor. The magnetic clutch is actuated when the air conditioning clutch compressor switch and the FAN switch located on the air conditioning control assembly are closed. When the switches are closed (air lever in A/C position and fan lever in low-medium or HI positions) the coil sets up a magnetic flux and attracts the armature plate (movable element of the clutch drive plate). The armature plate portion of the clutch drive plate moves forward and contacts the friction surface of the pulley assembly, thereby mechanically linking the compressor to the

motor. The compressor will operate continuously whenever the air conditioner clutch compressor switch and the FAN switch are closed. When one or both of the switches are open the armature plate will be released due to spring tension, and move away from the pulley assembly. This allows the pulley to rotate without driving the shaft. It may be noted that if the air conditioner system was in use when the engine was turned off, the armature plate may remain in contact with the pulley due to residual magnetism. When the engine is started the armature plate will separate from the pulley assembly. The coil is rated at 3.85 ohms (85°F.) and will draw 3.2 amperes at 12 volts d.c.

**b. Muffler**

A muffler is located on the discharge line side of the compressor. The muffler acts to reduce the characteristic pumping sound of the compressor. To further reduce compressor noise transfer through the body to the passenger compartment, a sheet of

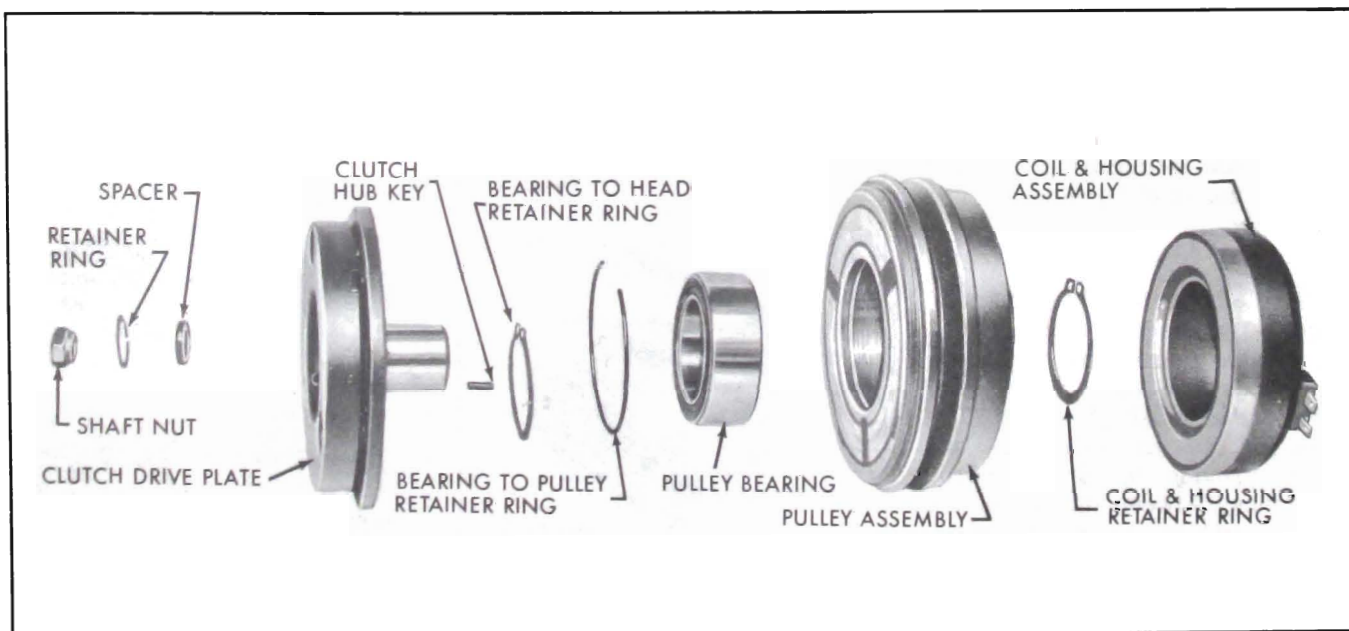

Figure 11-36—Magnetic Clutch Assembly

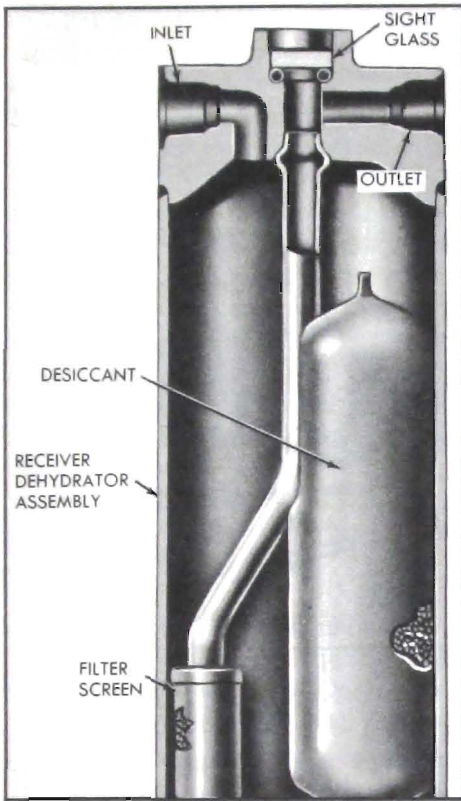

Figure 11-37—Receiver - Dehydrator Assembly

soft rubber insulation is wrapped around the outside of the muffler.

**c. Condenser**

The condenser which is made of aluminum is located in front of the radiator (see Figure 11-28) so that it receives a high volume of air flow. Air passing over the condenser absorbs the heat from the high pressure gas and causes the refrigerant to condense into a high pressure liquid.

**d. Receiver—Dehydrator**

The receiver-dehydrator is located on the right front side of the engine compartment (see Figure 11-28). The purpose of the receiver-dehydrator is twofold: the unit insures (provided the system is properly charged) a solid column of liquid refrigerant to the expansion valve at all times, and also absorbs any moisture in the system that might be present. A bag of desiccant is provided to absorb moisture. A liquid indicator sight glass (see Figure

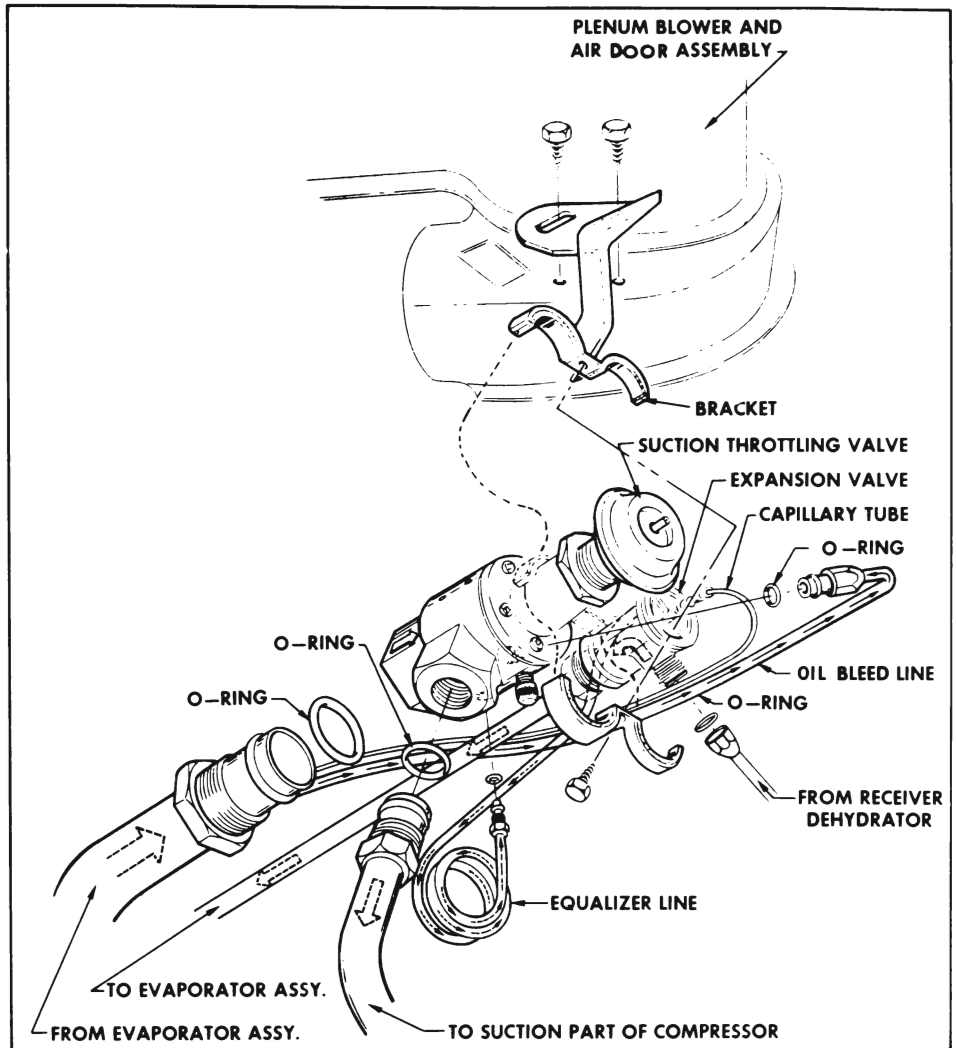

Figure 11-38—Suction Throttling Valve and Expansion Valve Installation

11-37) permits visual checking of the refrigerant flow for bubbles or foam. The appearance of bubbles or foam above an ambient temperature of 70° F. indicates air or an inadequate refrigerant charge. Bubbles or foam appearing at ambient temperatures below 70° F. do not necessarily indicate air or an inadequate charge and may appear even when the system is operating properly. A filter screen in the unit prevents foreign material from circulating through the system.

**e. Expansion Valve**

The expansion valve is located at the rear of the engine compartment on the passenger side of the car (see Figure 11-28). It is held

secure by a bracket which is attached to the plenum blower and air door assembly (see Figure 11-38). The function of the expansion valve is to automatically regulate the flow of refrigerant in the evaporator. The expansion valve is the dividing point in the system between the high and low pressure liquid refrigerant. A temperature sensing bulb is connected by a capillary tube to the expansion valve (see Figure 11-39). The temperature sensing bulb (clamped to the outlet pipe on the evaporator) measures the temperature of the evaporator outlet pipe and transmits the temperature variations to the expansion valve (see Figure 11-40). The capillary tube and bulb are filled with carbon dioxide and sealed to one side



of the expansion valve diaphragm. An increase in temperature will cause the carbon dioxide in the bulb and capillary tube to expand, overcoming the spring pressure and pushing the diaphragm against the operating pins (see Figure 11-39). This in turn will force the needle valve off its seat. When the refrigerant low pressure gas flowing through the outlet pipe of the evaporator becomes more than 6° warmer than the temperature at which it originally began to vaporize or boil, then the expansion valve will automatically allow more refrigerant to enter evaporator. If the temperature of the low pressure gas decreases more than 6° below the temperature at which it originally began to vaporize or boil, then the expansion valve will automatically reduce the flow of refrigerant. Thus, an increase or decrease in the flow of refrigerant through

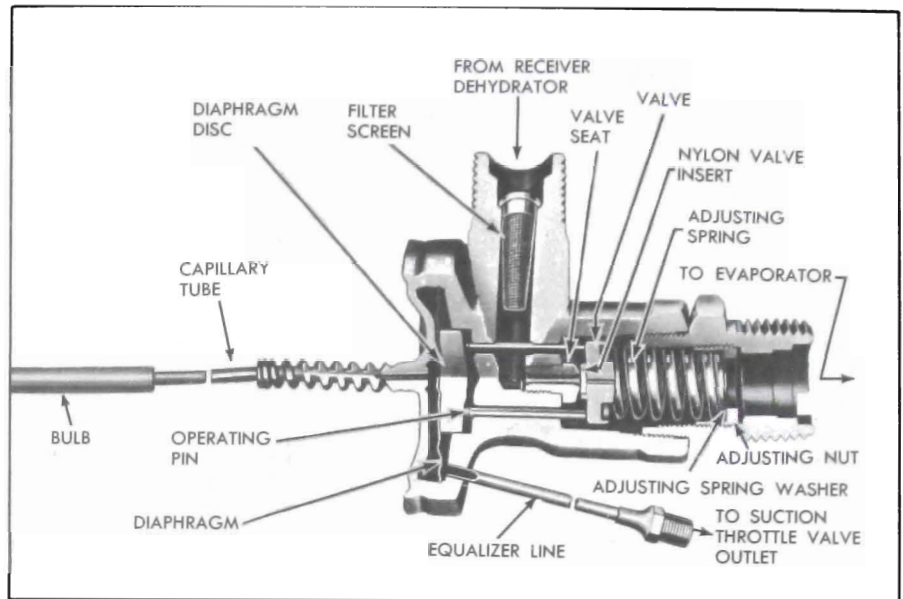

Figure 11-39—Expansion Valve

the evaporator will result in an increase or decrease in the cooling by the evaporator. The tem-

perature and volume of the air passing over the evaporator affects to some degree the rate of

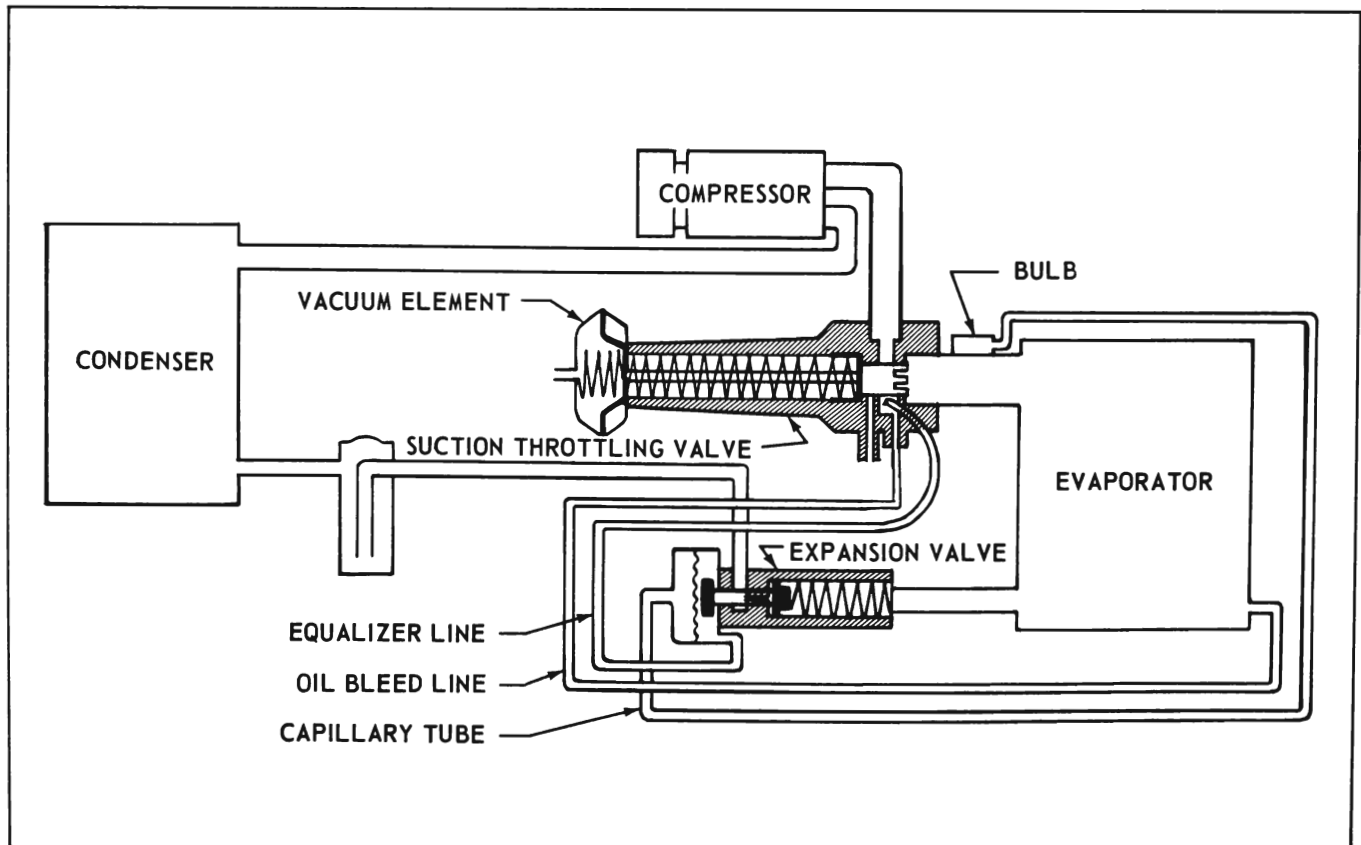

Figure 11-40—Suction Throttling Valve and Expansion Valve in Refrigeration Circuit

absorption of heat by the evaporator. As the ambient temperature varies, the frequency which the temperature bulb calls for more or less refrigerant will increase or decrease. When the air is very warm, the heat transfer from the air to the refrigerant is great and a greater quantity of refrigerant is required to maintain the temperature at the evaporator pipe at the predetermined valve. Conversely, cool days will result in slower heat transfer and thereby require lesser quantities of refrigerant to maintain the predetermined temperature of the evaporator outlet pipe.

An equalizer line connects the expansion valve to the suction throttling valve. The equalizer line is used primarily to prevent prolonged and constant operation of the compressor under conditions where it is not receiving enough refrigerant. This operation is undesirable due to the resultant noise factor, and also due to the possibility of subjecting the compressor to reduced oil return. The equalizer line functions to permit the outlet pressure of the suction throttling valve to be imposed on the diaphragm of the expansion valve. When the outlet pressure of the suction throttling valve drops below a predetermined pressure, this decrease in pressure is also transmitted to the diaphragm of the expansion valve, via the equalizer line. The expansion valve is caused to open and flood refrigerant through the evaporator, thereby resulting in an increase in the evaporator pressure. This action only occurs during times when the compressor capacity becomes greater than the evaporator output with the resultant drop in suction throttling valve outlet pressure.

**f. Evaporator**

The function of the evaporator (see Figure 11-41) is to cool and dehumidify the air flow before it

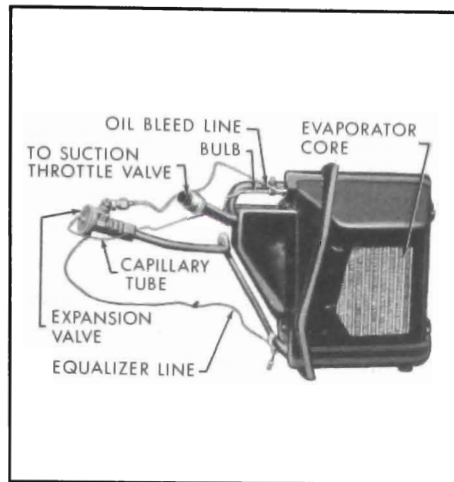

Figure 11-41—Evaporator Assembly

enters the passenger compartment. The evaporator assembly consists of an aluminum core enclosed in a reinforced plastic housing. A water drain port is located in the bottom of the housing. Two refrigerant pipe lines are connected to the side of the evaporator core; one at the bottom and one at the top. The expansion valve is attached to the

lower inlet pipe, and the suction throttling valve is attached to the upper outlet pipe. The temperature sensing bulb of the expansion valve is clamped to the outlet pipe of the evaporator core. The high pressure liquid refrigerant, after it is metered through the expansion valve, passes into the evaporator core where it is allowed to expand under reduced pressure. As a result of the reduced pressure the refrigerant begins to expand and return to the original gaseous state. To accomplish this transformation it begins to boil.

The boiling action of the refrigerant demands heat. To satisfy the demand for heat, the air passing over the core gives up heat to the evaporator and is subsequently cooled.

**g. Suction Throttling Valve**

The suction throttling valve is located on the discharge pipe of the evaporator core. The function

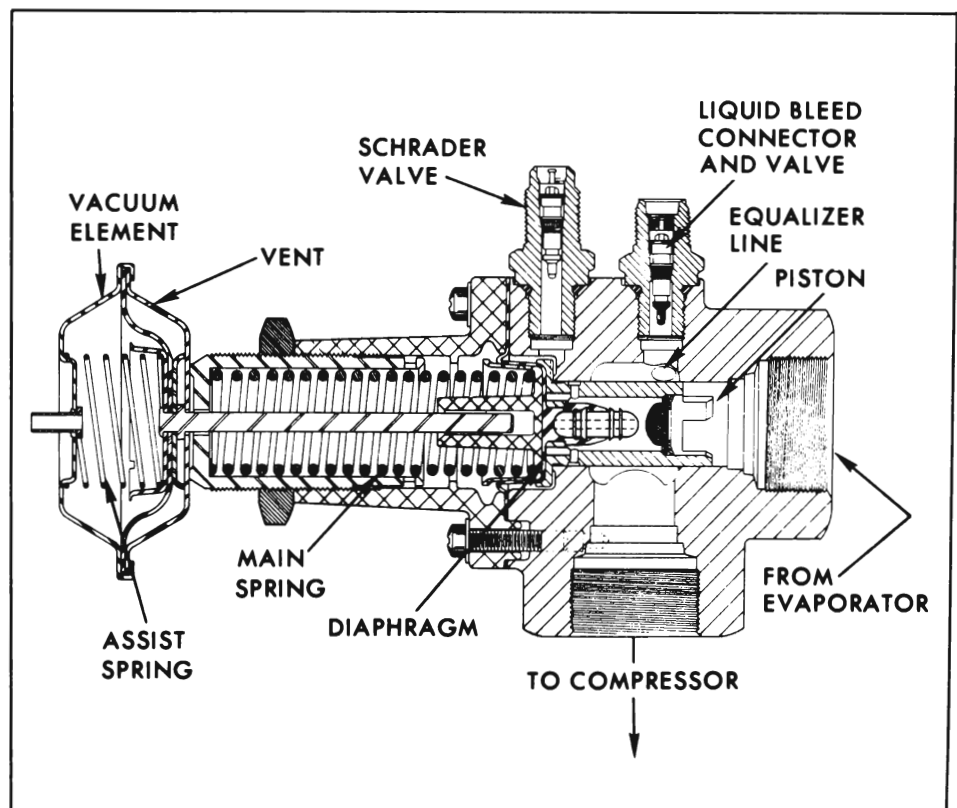

Figure 11-42—Suction Throttling Valve

of this valve (see Figure 11-42) is to maintain the evaporator at a predetermined pressure (approx. 29-31 psig) so that the temperature of the core remains relatively constant and the core does not freeze up. When the evaporator pressure rises above 29 psi, the suction throttling valve opens to permit the evaporator pressure (hence the evaporator temperature) to return to the predetermined level. Conversely, the suction throttling valve closes during periods when the evaporator pressure is low until sufficient pressure is built up. During times when the suction throttling valve is closed (light load operation), refrigerant is supplied to the compressor for lubrication purposes via the oil bleed line. The oil bleed line interconnects the bottom of the evaporator with the suction throttling valve at a point where it can bypass the valve piston when it is closed. A liquid bleed valve located in the suction throttling valve body, starts to open when there is a 5 psig pressure increase in the evaporator inlet pressure over the suction throttling valve outlet pressure. The bleed line valve will be fully open when there is greater than a 12 psig pressure differential between the STV and the evaporator. Refrigerant flows from the evaporator via the oil bleed line, around the closed piston of the suction throttling valve, and out the outlet of the suction throttling valve into the compressor.

A vacuum diaphragm unit is attached to the end of the valve and consists of a diaphragm element and a small spring. The function of the vacuum diaphragm is to permit a limited degree of regulation of the suction throttling valve. Essentially, the vacuum diaphragm unit adds an additional spring force to hold the piston closed. This additional pressure on the piston permits the evaporator to operate at higher pres-

ures, hence higher temperatures (pressure and temperature increase or decrease linearly). When no vacuum is applied to the diaphragm, the diaphragm spring is released and adds to the spring pressure (transmitted by the actuating pin) on the piston. This additional piston force causes the evaporator to operate at higher pressures—hence higher temperatures, or in other words, reduced cooling. When vacuum is applied to the diaphragm, the diaphragm spring is compressed, thereby reducing force to open piston. In this situation the suction throttling valve will open at lower pressures. The evaporator in turn will operate at lower pressures—hence colder temperatures (maximum cooling). Vacuum (maximum cooling) is applied whenever the temperature lever is in COLD position and FAN switch lever is on. No vacuum (reduced cooling) is applied when the temperature lever is moved just past COLD position. Application of vacuum is controlled by a vacuum disc switch located on the heater and defroster control assembly. The vacuum disc switch is actuated by a cam attached to the temperature control lever. The vacuum circuit is pictured in Figure 11-43.

#### h. Fuel Filter Assembly

Air conditioning equipped cars have the fuel vapor by-pass system. This system consists of a special fuel filter and fuel return lines which allow a constant flow of fuel from gas tank to filter and back to tank (see Figure 11-44). The system reduces the possibility of vapor lock when operating in extreme hot weather.

#### i. Fan Drive Clutch Assembly

During periods of operation when radiator discharge air temperature is low (below approximately

150° F), the fan clutch (see Figure 11-44) limits the fan speed to 800-1600 RPM. In this position, the clutch is disengaged since a small oil pump driven by the separator plate forces the silicone oil into the reservoir between the separator plate and the front cover assembly. In this position also, the passage from this cavity to the clutch area is closed by the coil spring leaf valve.

As operating conditions produce a high radiator discharge air temperature (above approximately 150° F.), the temperature sensitive bi-metal coil tightens to move the leaf valve (attached to the coil) which opens a port in the separator plate allowing flow of silicone oil into the clutch chamber to engage clutch providing a maximum fan speed of approximately 2350 RPM.

The clutch coil is calibrated so that at road load with an ambient temperature of approximately 90° F., the clutch is just at a point of shift between high and low fan speed.

No attempt should be made to disturb the calibration of the engine fan clutch assembly as each assembly is individually calibrated at the time of manufacture.

## 11-17 SERVICE PROCEDURES

Service procedures have been limited to removal of the unit, disassembly of unit (complicated disassembly procedures only), and reassembly and installation of units. It is presumed that all cleaning, inspection and checking of parts will be performed as required in accordance with good service procedures. Exceptions to the above mentioned standard practices will be noted at appropriate points within the disassembly procedures. The following service procedures are divided

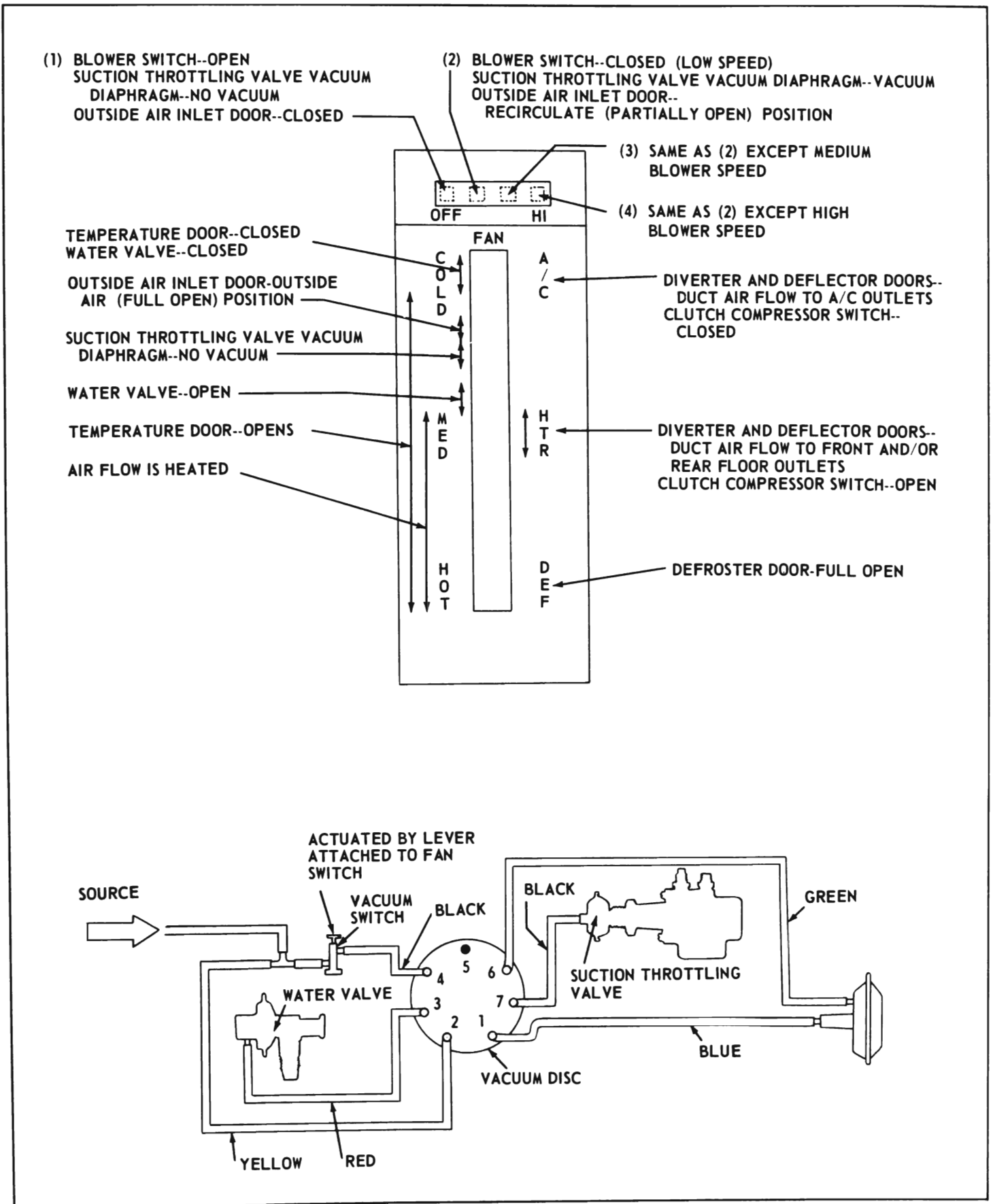

Figure 11-43—Heater System Vacuum Sequence

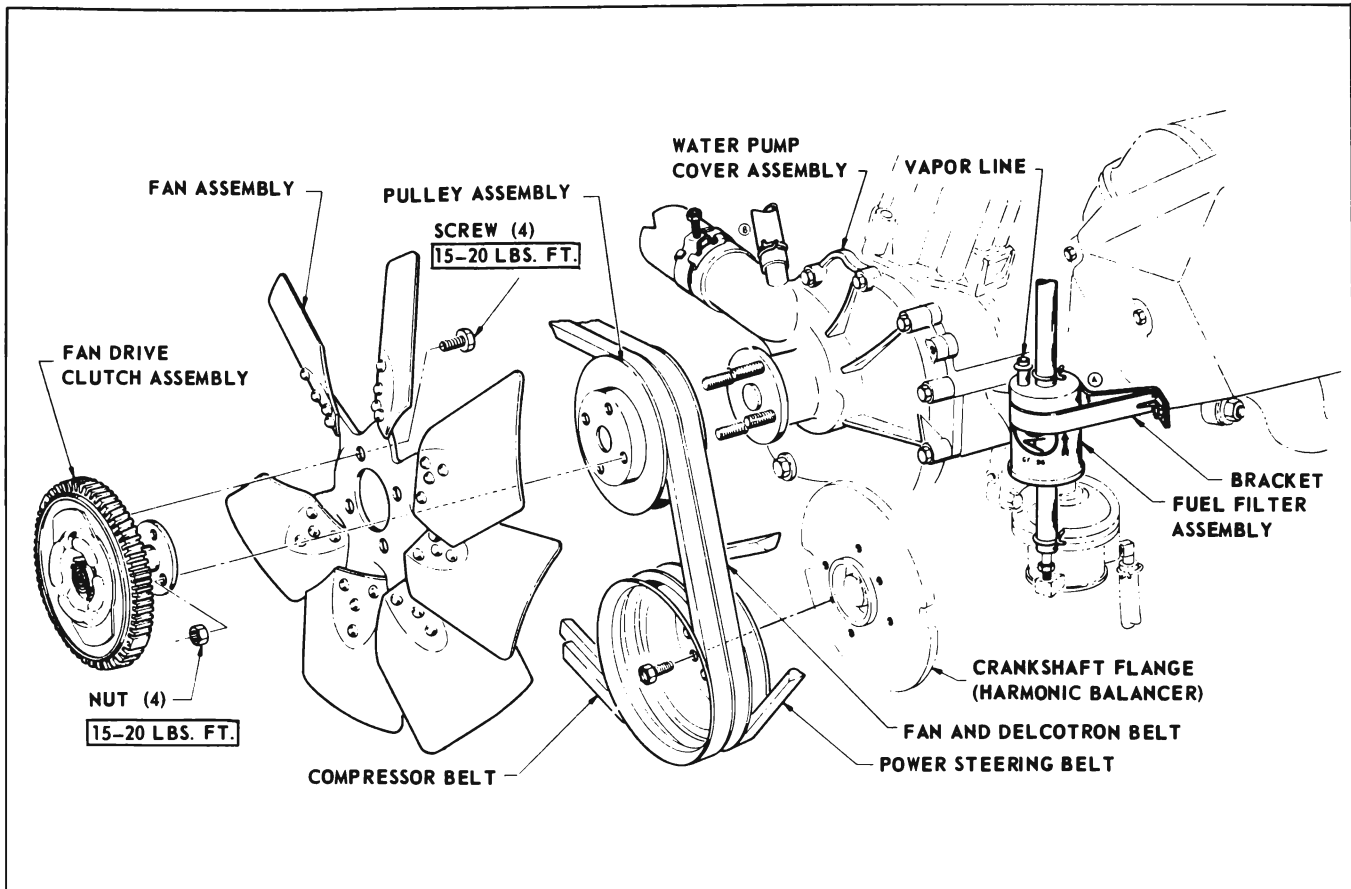

Figure 11-44—Fan Drive Clutch and Pulley Installation

into three general areas: servicing refrigerant charged components, servicing air distribution components and trouble diagnosis.

## 11-18 SERVICING REFRIGERANT CHARGED COMPONENTS

### a. Safety Precautions

The following safety precautions should always be followed when servicing refrigerant charged components:

1. Do not leave refrigerant-12 cylinder uncapped.
2. Do not carry cylinder in passenger compartment of car.
3. Do not subject cylinder to high temperatures.

4. Do not weld or steam clean on or near cylinder.

5. Do not fill cylinder completely.

6. Do not discharge vapor into area where flame is exposed or directly into engine air intake.

7. Do not expose eyes to liquid - wear safety goggles whenever discharging, charging or leak testing system.

### b. General Service Precautions for Refrigerant Circuit Components

1. All subassemblies are shipped sealed and dehydrated. They are to remain sealed until just prior to making connections.

2. All subassemblies should be at room temperature before uncapping. This prevents condensation

of moisture from air that enters the system.

3. All precautions should be taken to prevent damage to fittings or connections. Even minute damage to a connection could cause it to leak.

4. Any fittings with grease or dirt on them should be wiped clean with a cloth dipped in alcohol.

5. Do not clean fitting or hoses with chlorinated salts because they are contaminants. If dirt, grease or moisture gets inside the pipes and cannot be removed, the pipe is to be replaced.

6. Use a small amount of refrigeration oil on all tube and hose connecting joints, and lubricate the "O" ring gasket with this oil before assembling the joint. The oil will help in effecting a leak-proof joint and assist the "O"

Metal Tube Outside Diameter	Thread and Fitting Size	Steel Tubing Torque Lb.-Ft.	Aluminum or Copper Tubing Torque Lb.-Ft.	Nominal Torque Wrench Span
3/4	7/16	10-15	5-7	5/8
5/8	5/8	30-35	11-13	3/4
1/2	3/4	30-35	11-13	7/8
3/8	7/8	30-35	18-21	1 1/16
1/4	1 1/16	30-35	23-28	1 1/4

If a connection is made with steel to aluminum or copper, use torques for aluminum. In other words, use the lower torque specification.

Use steel torques only when both ends of connection are steel.

Figure 11-45—Pipe and Hose Connection Torque Chart

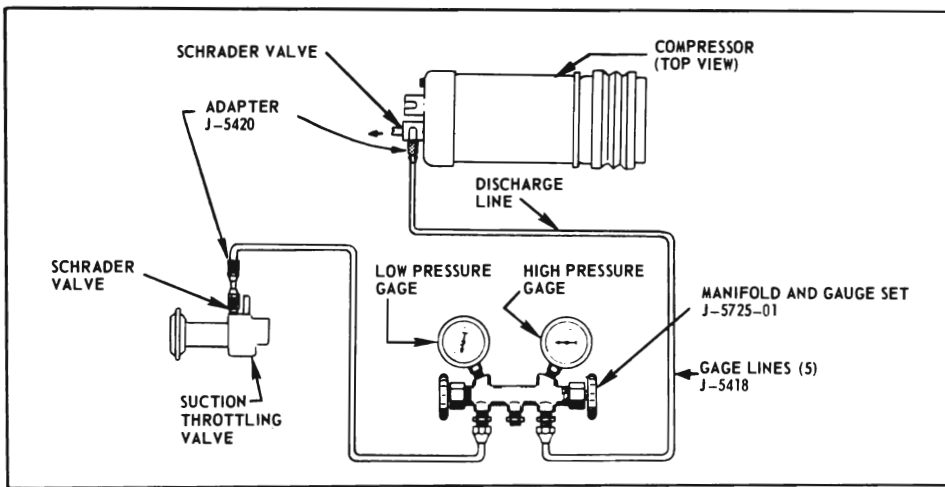

Figure 11-46—Functional Test Set-Up

ring to slip into the proper location without being cut or damaged.

7. When tightening joints, use a second wrench to hold the stationary part of the connection to prevent twisting and to prevent hose kinking. Kinked hoses are

apt to transmit noise and vibration.

8. Tighten all connections in accordance with recommended torques (ref. Figure 11-45).

9. Do not connect receiver-dehydrator assembly until all

other connections have been made. This is necessary to insure maximum moisture removal from system.

10. It is important that air conditioning hoses do not rest on or contact body sheet metal except where necessary. Because of the high frequency at which the compressor operates, the passenger compartment is susceptible to transfer of noise.

**c. Functional Testing System**

Function testing is a measurement of the air conditioner system performance to determine if discharge air temperature, pressure in suction line, and pressure in discharge line are within specific limitations.

To perform functional test proceed as follows:

4000, 4100 AND 4300 SERIES FUNCTIONAL TEST						
TEST #1						
Ambient Temperature (°F)	Evaporator Pressure (PSIG)	Compressor Pressure (PSIG)	Right A/C Outlet (PSIG)	Left A/C Outlet (PSIG)		
80	28.5 - 30	200 - 245	40 - 43	40 - 43		
90	28.5 - 30	240 - 290	42 - 45	43 - 45		
100	28.5 - 30	270 - 330	44 - 47	45 - 48		
110	28.5 - 30	310 - 345	47 - 52			
TEST #2						
Ambient Temperature (°F)	Humidity	Engine RPM	Evaporator Pressure (PSIG)	Compressor Pressure (PSIG)	Right A/C Outlet (°F)	Left A/C Outlet (°F)
90	High	480	35	210	59	57
90	Low	400	35	190	54	52
100	High	570	35	235	60	58
100	Low	550	35	230	65	54
110	High	940	35	320	59	59
110	Low	615	35	270	58	58

Figure 11-47—Air Conditioner Functional Test Table

1. Remove protective caps from Schrader valve located on suction throttle valve and Schrader valve located on compressor discharge port.
2. Interconnect Manifold and Gauge Set (J-5725-01), Gauge Charging Lines (J-5418) and Gauge Adaptors (J-5420) to air conditioning system as shown in Figure 11-46.
3. Open doors and hood of car to be tested.
4. Set temperature lever to COLD position and FAN lever to HI. Air control lever in A/C position.
5. Idle engine at 2000 RPM.
6. Place a fan in front of radiator grille to insure minimum differential between temperature of air passing through radiator grille and condenser, and temperature of air flow through cowl air inlet and past evaporator core.
7. Measure relative humidity and ambient temperature in immediate vicinity of car to be tested. The temperature obtained at the air outlets will be lower on dry days and higher on humid days.
8. Open all air conditioner outlets and measure temperature at right and left outlets.
9. Compare the actual pressures and temperatures with the pressures and temperatures indicated in Test #1 of Functional Test Table (see Figure 11-47). If the relationship, specified in Test #1 of Figure 11-47, between pressures and temperatures is not obtained, adjust the suction throttling valve as required (ref. subpar. r).
10. Road test the car and recheck outlet temperatures. If outlet temperatures are not satisfactory, readjust the suction throttling valve to achieve the pressures and temperatures specified in Test #2 of Functional Test Table. The engine speed should be adjusted to the ambient temperature and humidity.

#### d. Leak Testing System

The following two methods are recommended when attempting to locate refrigerant leaks in the system. Loss of refrigerant is always indicative of a leak since refrigerant is not consumed and does not wear out.

1. Open Flame Method - This method utilizes a gas operated torch type Leak Detector (J-6084). Use of this method is recommended when checking for leaks in confined areas. To perform test, light torch and adjust to obtain a pale blue flame, approximately 3/8 inch in height, in burner.

Explore for leaks by moving end of search tube around suspected area. Check bottom of connections since refrigerant-12 is heavier than air and will be more apparent at underside of fittings. The flame color will turn yellow-green when a small leak is detected. Large leaks will turn the flame blue or purple.

CAUTION: Do not breath fumes resulting from burning of refrigerant gas. These fumes are extremely poisonous.

2. Liquid Leak Detectors - This method utilizes a solution which will bubble (soap solution) to signify a gas leak. Use of this method of checking is recommended for locating small leaks.

#### e. Discharging System

Removal of any part in the refrigerant circuit will require discharging of the entire system.

1. Remove protective cap from the Schrader valve located on the suction throttling valve and Schrader valve located on discharge port of compressor.
2. Install Adapters (J-5420) onto each Schrader valve, and connect a Gauge Charging Line (J-5418) between each adapter

and the outer connecting ports of the manifold and Gauge Set (J-5725-01. Both valves of manifold and gauge set must be closed.

3. Hold a large size rag over center port of manifold and gauge set and slowly open both valves on manifold and gauge set until refrigerant starts to flow without discharging refrigerant oil.

NOTE: Do not open valves too fast as oil will be blown out of system.

#### f. Replacement of Oil Loss in System

The oil in the refrigerant circuit does not remain in the compressor during system operation, but circulates throughout the system. The compressor is initially charged with 10-1/2 oz. of 525 viscosity oil. After system has been in operation the oil content in the compressor will vary depending on the engine RPM and air conditioning load. At higher engine RPM's a lesser amount of oil will be retained in the compressor reservoir. It is important that the total system oil content does not vary from a total of 10-1/2 oz. Excessive oil content will reduce cooling capacity. Inadequate oil content may result in damage to compressor moving parts.

The refrigerant system will not require adding of oil unless there is an oil loss because of a ruptured line, badly leaking compressor seal, replacement of a component, or oil loss due to a collision. Oil is generally added to the system via the oil drain hole in the lower side of the compressor. To add oil to the system via the compressor, the compressor must be removed. If no major loss of oil has occurred and a component (condenser, receiver-dehydrator or evaporator) is removed for servicing, the oil may be added directly to the component. To add oil to a component

CONDITION	AMOUNT OF OIL DRAINED FROM COMPRESSOR	AMOUNT OF 525 OIL TO INSTALL IN COMPRESSOR
<p>1. Major loss of oil and a component (condenser, receiver-dehydrator, or evaporator) has to be replaced.</p>	<p>a. More than 4 oz.</p> <p>b. Less than 4 oz.</p>	<p>a. Amount drained from compressor plus amount for component being replaced:</p> <p>Evaporator — Add 2 oz. Condenser — Add 1 oz. Receiver Dehydrator — Add 1 oz.</p> <p>b. Install 6 oz. plus amount for component being replaced as shown above.</p>
<p>2. Compressor being replaced with a service replacement compressor —no major oil loss.</p>	<p>a. More than 1-1/2 oz.</p> <p>b. Less than 1-1/2 oz.</p>	<p>a. Same amount as drained from compressor being replaced.</p> <p>b. Install 6 oz.</p>
<p>3. Compressor being replaced with a service replacement compressor —major oil loss evident.</p>	<p>a. More than 4 oz.</p> <p>b. Less than 4 oz.</p>	<p>a. Same amount as drained from compressor being replaced.</p> <p>b. Install 6 oz.</p>
<p>4. Compressor being rebuilt or repaired—no major oil loss evident.</p>	<p>a. More than 1-1/2 oz.</p> <p>b. Less than 1-1/2 oz.</p>	<p>a. Same amount as drained from compressor plus 1 oz. additional.</p> <p>b. Install 7 oz.</p>
<p>5. Compressor being rebuilt or repaired—major loss of oil evident.</p>	<p>a. More than 4 oz.</p> <p>b. Less than 4 oz.</p>	<p>a. Same amount as drained from compressor plus 1 oz. additional.</p> <p>b. Install 7 oz.</p>

Figure 11-48—Oil Replacement Table

removed for servicing and when no major loss has occurred, drain and measure oil in component, replace with a like amount. To add oil to the system when a major loss of oil is evidenced, or when compressor is being serviced, remove compressor, drain and measure oil, and replace oil

amount specified in Figure 11-48. If foreign material or moisture is noted in oil drained from system, it is recommended that the entire system be flushed (ref. subpar. g) and the receiver-dehydrator be replaced. A full oil charge of 10-1/2 oz. of 525 viscosity refrigerant oil should be

replaced in the system. It should be noted that all service replacement compressors will be supplied with 10-1/2 oz. of oil. In most cases it will be necessary to drain oil from service replacement compressor and refill it with amount as specified in table (ref. Figure 11-48).



### g. Flushing System

Flushing of the system may involve all the components of the system or individual components in the system. The components may be flushed while mounted in the engine compartment or may be removed for flushing. When a component is not removed, disconnect all refrigerant lines attached to component. To perform flushing operation, connect a cylinder of refrigerant-12 to the component to be flushed, then invert the cylinder and open the cylinder valve so that the liquid refrigerant pours out and through the component.

**CAUTION:** When liquid refrigerant-12 reaches atmospheric pressure it immediately drops to -21.7°F. Insure that area immediately surrounding outlet of component is clear of anything that may be damaged by contact because of the sudden drop in temperature.

In all cases where flushing operation is performed, the receiver-dehydrator and the filter screen on the expansion valve should be replaced. If the evaporator assembly is flushed while installed in the car, the temperature bulb on the evaporator outlet pipe must be disconnected to keep the expansion valve from closing at the inlet source.

**NOTE:** It is recommended that dry nitrogen be used as a flushing agent due to the low cost involved. In addition, dry nitrogen will not cause a temperature drop, as in the case of refrigerant-12, which results in thickening of refrigerant oil. Dry nitrogen has the additional advantage of removing moisture from the system.

### h. Removal and Installation of Compressor

#### REMOVAL

1. Discharge refrigerant from system (ref. subpar. "e").

2. Disconnect leads from compressor magnetic clutch assembly.

3. Remove bolt and plate holding suction and discharge lines into rear head (see Figure 11-28). Disengage both lines from compressor and tape securely closed openings in both lines and ports in rear head. **NOTE:** It is important to seal compressor ports to avoid an undeterminable loss of refrigerant oil and also to prevent foreign material and moisture from entering compressor.

4. Remove bolt holding suction line clamp to compressor (see Figure 11-49).

5. Loosen bolts in slots of front and rear adapter plates, tilt compressor inward, and move belt off compressor pulley.

6. Remove two bolts holding rear adapter plate to compressor, two bolts attaching front adapter plate to Delcotron and compressor mounting bracket, and lift out compressor.

**NOTE:** During removal maintain the compressor positioned so that the sump is downward. Do not rotate compressor shaft.

#### INSTALLATION

7. Installation is reverse of removal. Torque bolts as specified in Figure 11-49.

**NOTE:** Insure that compressor has sufficient oil charge (ref. subpar. f).

8. Use new "O" rings when attaching suction and discharge lines.

9. Adjust compressor belt tension to 110 pounds using Belt Tension Gauge (J-7316).

10. Charge compressor (ref. subpar. "s").

### i. Disassembly and Reassembly of Clutch Drive Plate and Shaft Seal

**NOTE:** The following procedure can be performed with the compressor mounted in the engine compartment, or the compressor may be removed for greater accessibility. The following procedure is performed under the presumption that the compressor has been removed.

#### DISASSEMBLY

1. Firmly clamp Holding Fixture (J-9396) in a vise and attach compressor assembly to fixture (see Figure 11-50).

2. Hold hub of clutch drive plate with Wrench (J-9403). Using special thin wall 9/16 inch Socket (J-9399) and 3/8 inch drive, take off shaft nut (see Figure 11-36).

3. Install threaded Hub Puller (J-9401) onto hub of clutch drive plate (see Figure 11-51). Hold body of hub puller with wrench, tighten center screw of hub puller, and lift off clutch drive plate and woodruff key.

4. Using No. 21 Truarc Pliers (J-5403) take out retainer ring from hub of clutch drive plate (see Figure 11-52). Lift out spacer.

5. Using No. 21 Truarc Pliers (J-5403) take out seal seat retainer ring (see Figure 11-53) from inside front head.

6. Disassemble shaft seal seat (see Figure 11-54) by use of Seal Seat Remover and Installer (J-9393). Grasp flange of shaft seal seat with tool and pull straight out.

7. Using Seal Remover and Installer (J-9392) insert tool into hub of front head, press downward and twist clockwise to engage tabs of shaft seal, and

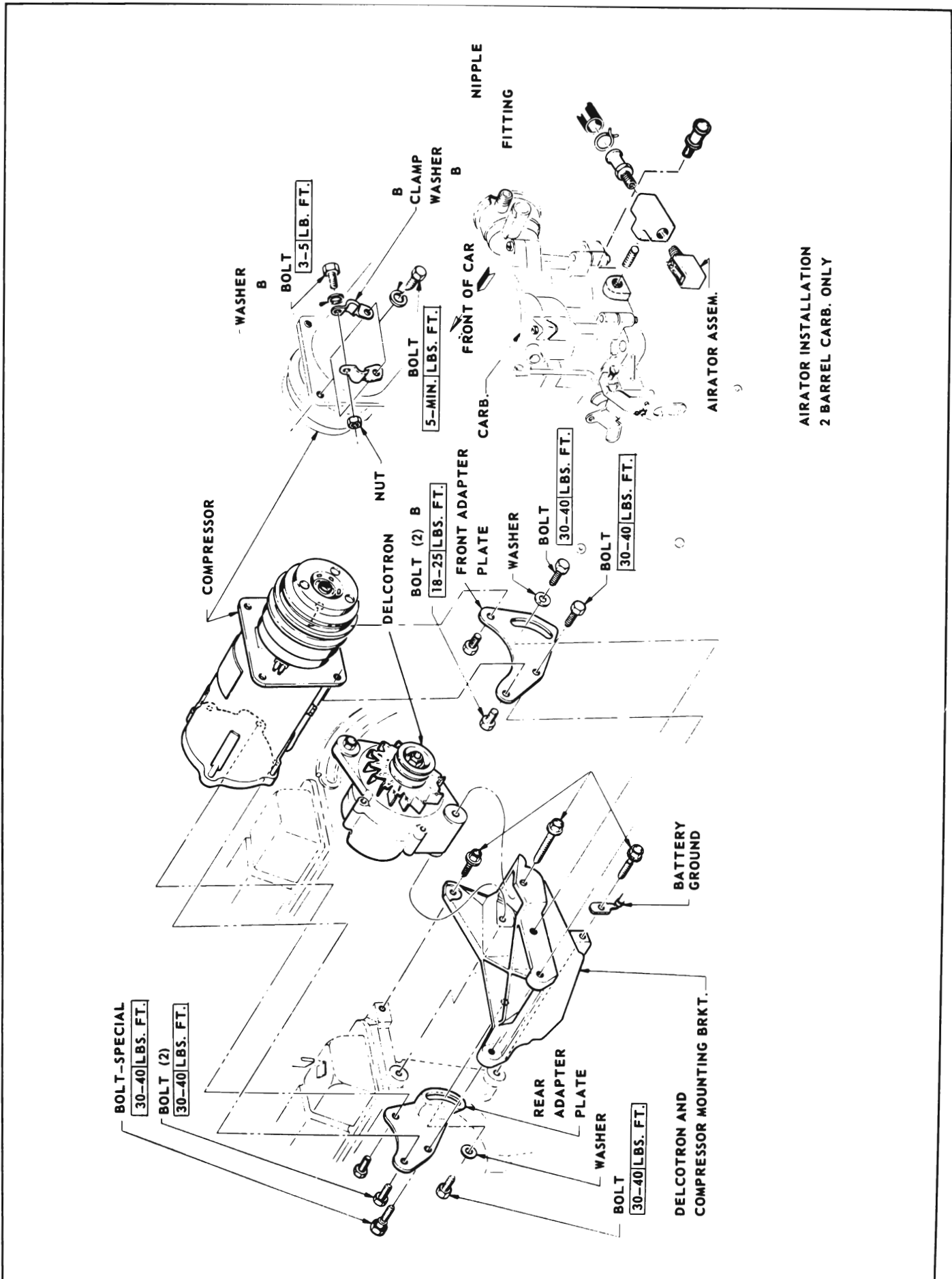

Figure 11-49—Compressor Removal and Installation

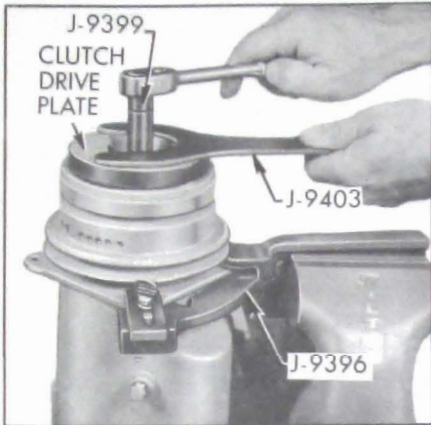

Figure 11-50—Removing or Installing Shaft Nut

gently but firmly, pull tool straight out (see Figure 11-55).

8. Take out seal seat “O” ring (see Figure 11-56) from inside hub of front head using “O” ring Remover (J-9553).

**REASSEMBLY**

9. Liberally coat seal seat “O” ring with 525 viscosity oil and insert “O” ring into hub of front head (see Figure 11-57) with seal seat “O” ring Installer (J-21508).

10. Generously coat shaft seal with 525 viscosity oil, mount shaft seal on Seal Remover and Installer (J-9392) and insert in hub of front head (see Figure 11-55).

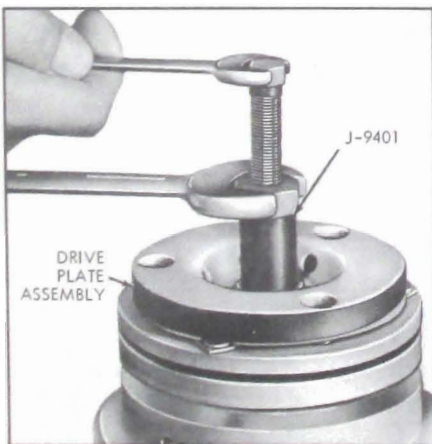

Figure 11-51—Removing Clutch Drive Plate

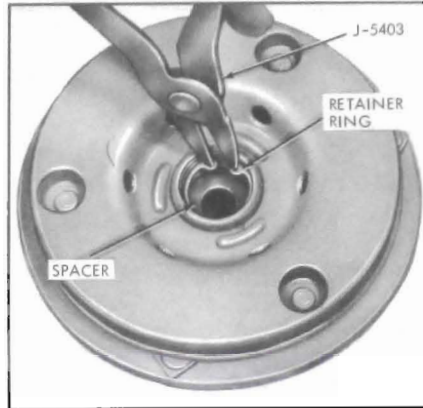

Figure 11-52—Removing or Installing Retainer Ring in Clutch Drive Plate

Press downward and turn counterclockwise on installer to release shaft seal.

11. Lubricate shaft seal seat with 525 viscosity oil, mount seat on Seal Seat Remover and Installer (J-9393) and reassemble into hub of front head (see Figure 11-54).

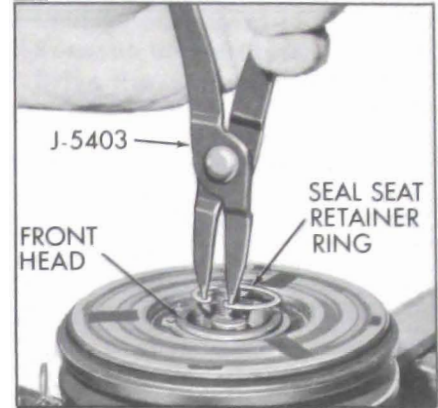

Figure 11-53—Removing or Installing Shaft Seal Seat Retaining Ring

12. Using No. 21 Truarc Pliers (J-5403) reassemble seal seat retaining ring (flat side of retainer ring downward) into hub of front head and engage retainer ring in ring groove (see Figure 11-53). If necessary, retainer ring may be pushed into groove using sleeve

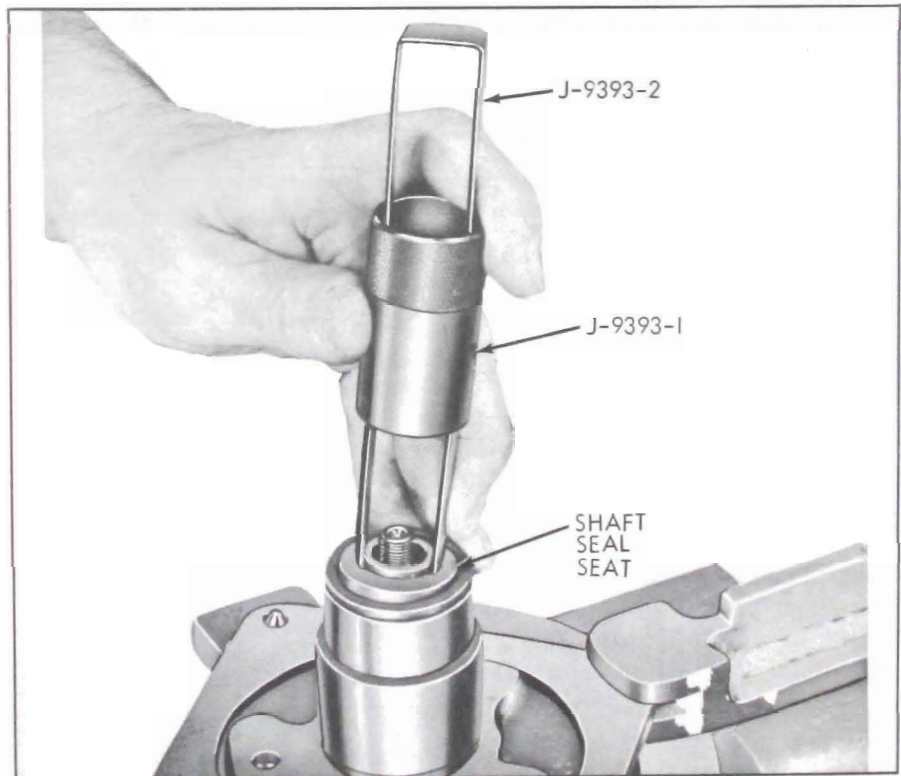

Figure 11-54—Removing or Installing Shaft Seal Seat

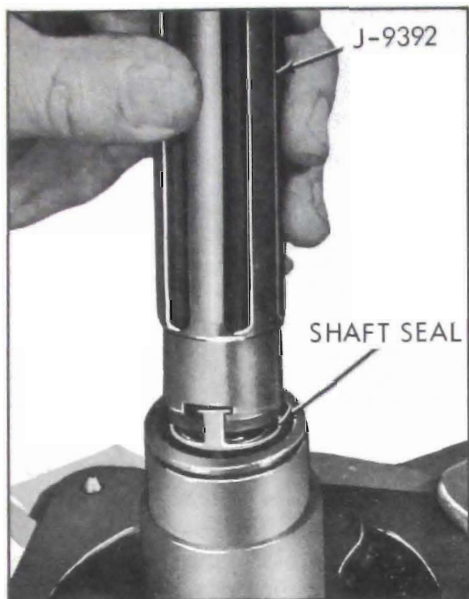

Figure 11-55—Removing or Installing Shaft Seal

portion of Seal Seat Remover and Installer (J-9393).

13. Attach Compressor Leak Test Fixture (J-9527) on rear head of compressor and connect gauge charging lines as shown in Figure 11-58. Pressurize suction side of compressor with refrigerant 12 (cylinder at room temperature). Temporarily install shaft nut and rotate compressor shaft several times. Leak test seal and correct any leaks as necessary. Remove and discard shaft nut.

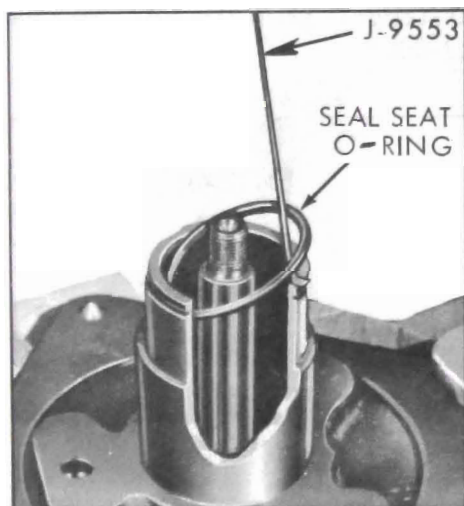

Figure 11-56—Removing Seal Seat O-Ring

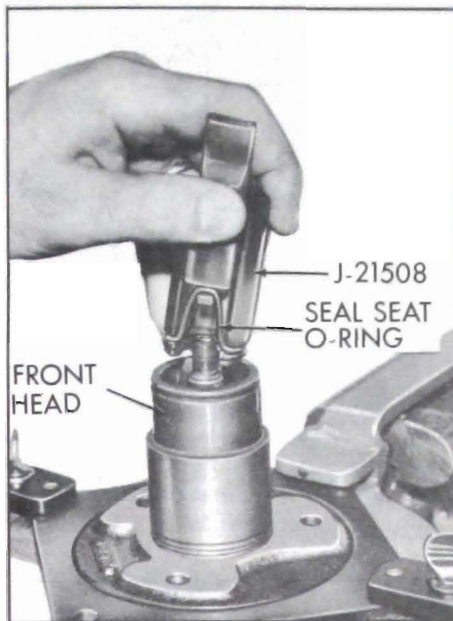

Figure 11-57—Installing Seal Seat O-Ring

14. Insert woodruff key into hub of clutch drive plate so that it projects out approximately 3/16 inch (see Figure 11-59) and position clutch drive plate onto shaft.

15. Using Drive Plate Installer (J-9480), screw installer on end of shaft as shown in Figure 11-60. Hold nut and turn bolt until clutch drive plate is pressed within 3/32 inch of the pulley assembly.

16. Reassemble spacer into hub of clutch drive plate (see Figure 11-52).

17. Reassemble retainer ring into hub of clutch drive plate (see Figure 11-52) using No. 21 Truarc Pliers (J-5403).

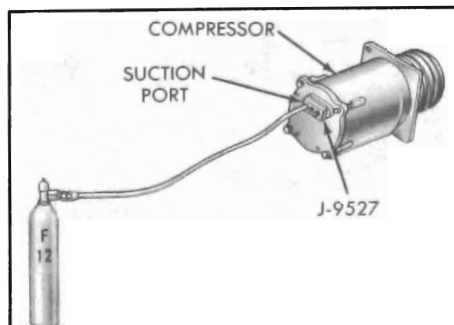

Figure 11-58—Leak Testing Shaft Seal and Seal Seat O-Ring

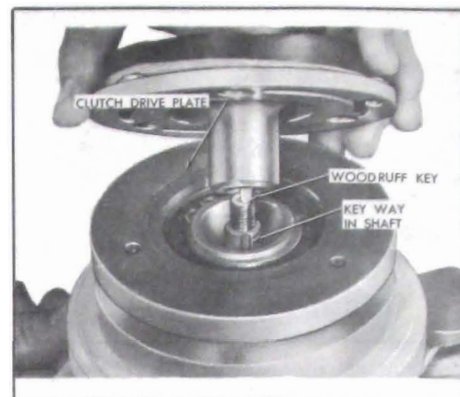

Figure 11-59—Positioning Clutch Drive Plate on Shaft

18. Thread on new shaft nut using special thin wall 9/16 Socket (J-9399) and 3/8 inch drive. Hold clutch drive plate secure using Wrench (J-9403) and torque nut to 15 lb. ft. The air gap between the friction surfaces of the pulley assembly and clutch drive plate should be approximately 1/32 to 1/16 inch (see Figure 11-61).

### i. Disassembly and Reassembly of Pulley Assembly, and Coil and Housing Assembly

#### DISASSEMBLY

1. Disassemble clutch drive plate (ref. subpar. "i").
2. Using No. 26 Truarc Pliers (J-6435) take out bearing to head retainer ring (see Figure 11-62).

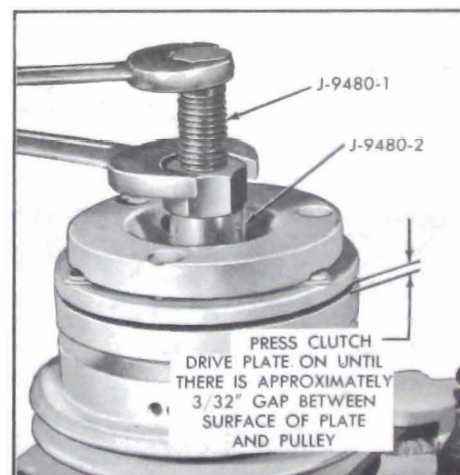

Figure 11-60—Installing Clutch Drive Plate

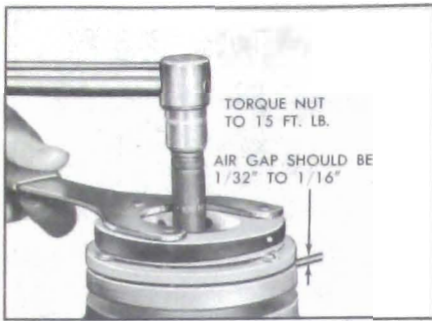

Figure 11-61—Torquing Shaft Nut

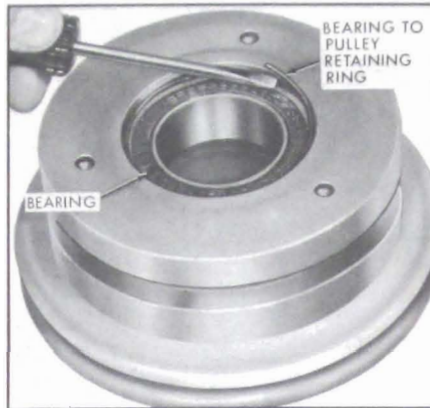

Figure 11-64—Removing Bearing Retainer Wire



Figure 11-67—Installing Bearing into Pulley Assembly

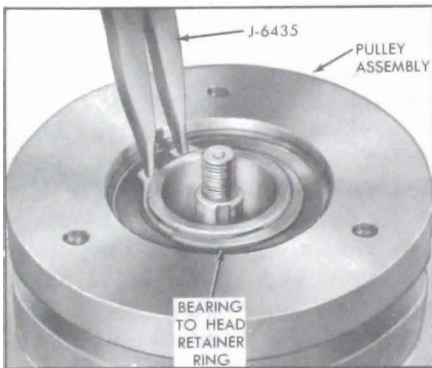

Figure 11-62—Removing or Installing Bearing to Head Retainer Ring

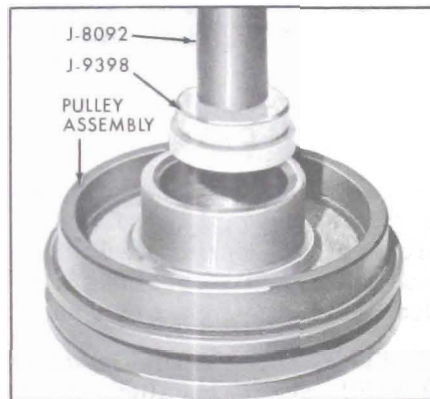

Figure 11-65—Removing Bearing from Pulley Assembly

5. Drive out bearing (see Figure 11-65) by use of Puller Pilot (J-9398) and Handle (J-8092).

**NOTE:** Do not take out pulley bearing unless it is going to be replaced as removal may damage bearing.

6. Mark position of coil and housing assembly in relationship to shell of compressor, withdraw coil and housing retaining ring (see Figure 11-66) using No. 26 Truarc Pliers (J-6435), and lift out coil and housing assembly.

**REASSEMBLY**

7. Reassemble coil and housing assembly reverse of disassembly.

8. Drive new bearing into pulley assembly (see Figure 11-67) with Installer (J-9481) and Handle (J-8092).

3. Place Puller Pilot (J-9395) on hub of front head and take off pulley assembly (see Figure 11-63) using Pulley Puller (J-8433).

**CAUTION:** Puller pilot must be used. If force is exerted on shaft, damage will result to the internal parts of the compressor.

4. Withdraw bearing to pulley retaining ring with a small screwdriver (see Figure 11-64).



Figure 11-63—Removing Pulley Assembly

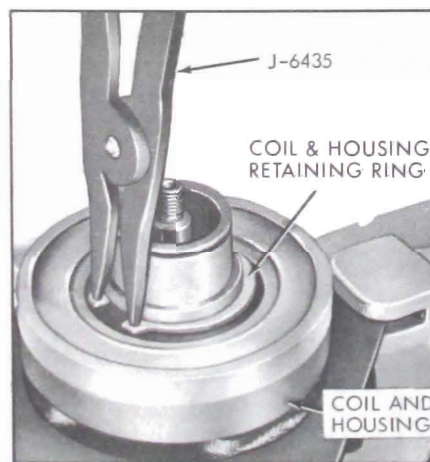

Figure 11-66—Removing and Installing Coil and Housing Retainer Ring

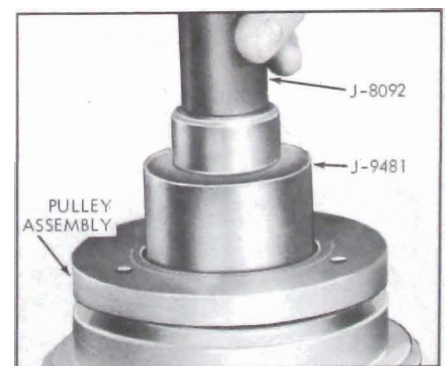

Figure 11-68—Installing Pulley Assembly

9. Lock bearing in position with bearing to pulley retainer ring (see Figure 11-64) using No. 26 Truarc Pliers (J-6435).

10. Drive pulley assembly onto hub of front head (see Figure 11-68) using Installer (J-9481) and Handle (J-8092).

**NOTE:** If the pulley assembly is going to be reused, clean the friction surface with trichlorethylene, alcohol or a similar solvent.

11. Lock pulley assembly in position with bearing to head retainer ring (flat side of retainer ring downward) using No. 26 Truarc Pliers (J-6435). See Figure 11-62.

12. Reassemble clutch drive plate (ref. subpar. "i").

**k. Disassembly and Reassembly of Internal Parts of Compressor and Leak Testing Compressor**

**CAUTION:** A clean work area and a place for each part removed is required to properly disassemble and reassemble compressor. The internal ports of the compressor must be kept free of dirt or foreign material.

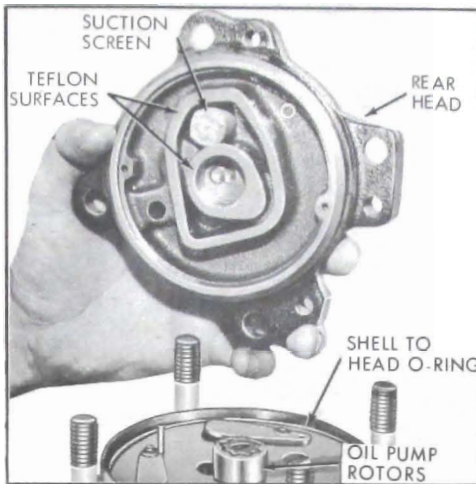

Figure 11-70—Rear Head Removal

When working with compressor, under no circumstances should compressor be rested on pulley end.

**DISASSEMBLY OF REAR HEAD, OIL PUMP, REAR DISCHARGE VALVE PLATE, AND REAR SUCTION VALVE REED DISC**

**NOTE:** If compressor is not going to be disassembled any further than removal of rear head, oil pump, rear discharge valve plate, or rear suction valve reed disc, omit Steps "1, 2 and 4".

1. Disassemble clutch drive plate and shaft seal (ref. subpar. "i").

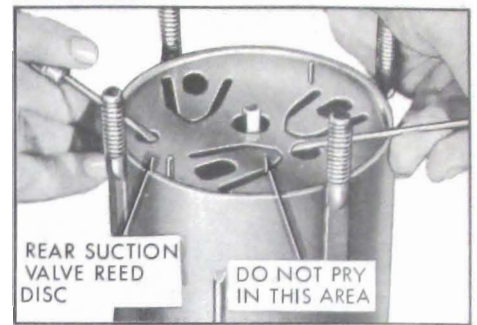

Figure 11-72—Removing Rear Suction Valve Reed Disc

2. Disassemble pulley assembly, and coil and housing assembly (ref. subpar. "j").

3. Clean surface of compressor shell and dry with compressed air.

4. Remove compressor from Holding Fixture (J-9396), unscrew drain screw, and remove oil plugs in ports of rear head. Drain, measure and record amount of oil in compressor.

5. Reinstall compressor in Holding Fixture (J-9396) positioned as shown in Figure 11-69.

6. Unscrew and discard four lock nuts from rear of compressor, and lift off rear head by tapping head with a mallet.

**NOTE:** If teflon surfaces are damaged (see Figure 11-70), replace rear head. Clean or replace suction screen as necessary.

7. Pencil mark top side of both oil pump rotors and lift out rotors.

**NOTE:** Replace both oil pump inner and outer rotors if one or both are damaged or worn.

8. Take out and discard shell to head "O" ring.

9. Carefully pry out rear discharge valve plate and rear suction valve reed disc with screwdrivers (see Figures 11-71 and 11-72). Check both pieces and replace as necessary.

**NOTE:** During disassembly, the disc generally adheres to the plate and both pieces lift out together.

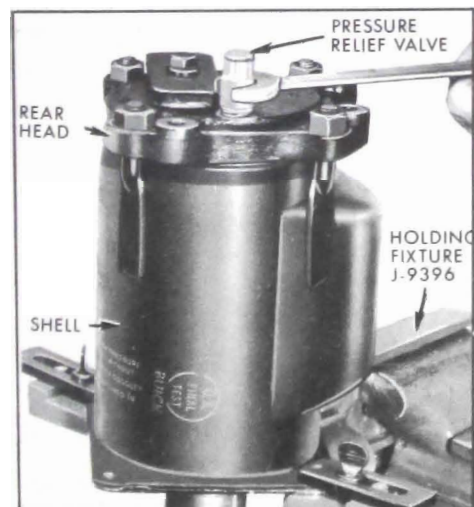

Figure 11-69—Compressor Installed in Holding Fixture

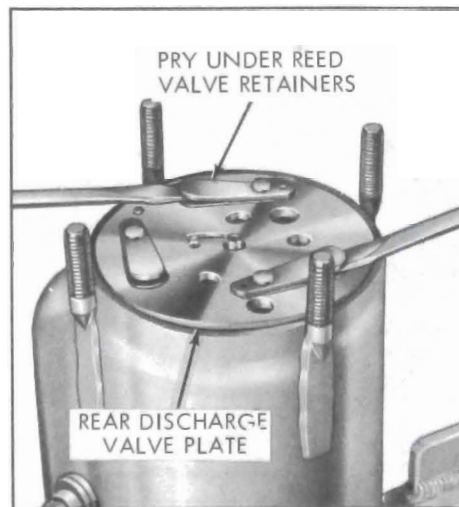

Figure 11-71—Removing Rear Discharge Valve Plate

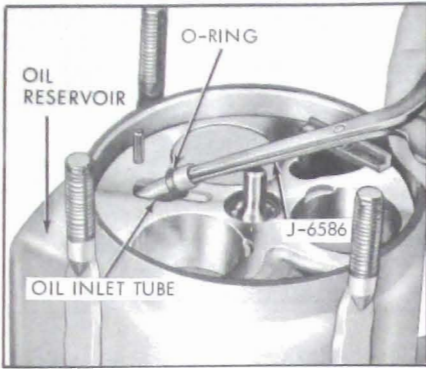

Figure 11-73—Removing Oil Inlet Tube

**REMOVING CYLINDER ASSEMBLY, AND DISASSEMBLY OF FRONT SUCTION VALVE REED DISC, FRONT DISCHARGE VALVE PLATE, AND FRONT HEAD**

10. Pull out oil inlet tube (see Figure 11-73) and oil inlet tube "O" ring using Remover (J-6586).

11. Push shaft upward from front head and lift out cylinder assembly (see Figure 11-74), front suction valve reed disc, and front discharge valve plate.

NOTE: When lifting out the cylinder assembly, the front suction valve reed disc and the front discharge valve plate generally adhere to the cylinder assembly and lift out with it. Check and replace if necessary.

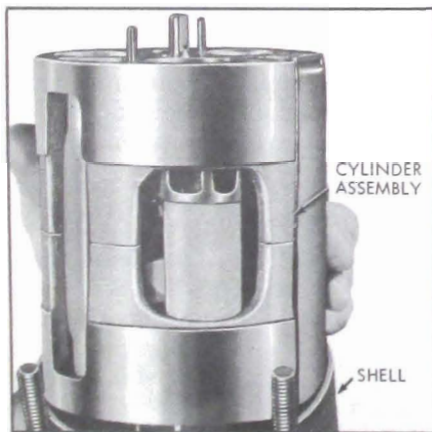

Figure 11-74—Removing Cylinder Assembly

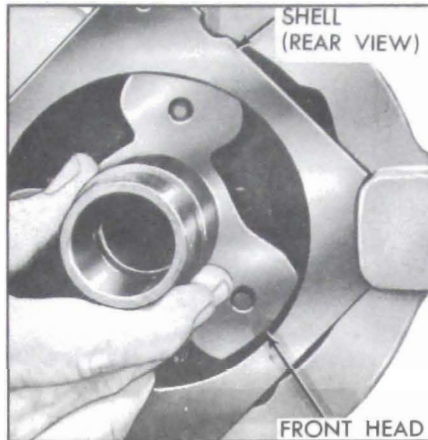

Figure 11-75—Removing Front Head

Depending on wear or damage to cylinder assembly, it may be advisable to replace complete cylinder assembly. If service replacement cylinder is used omit following steps and continue on with subparagraph entitled "FINAL REASSEMBLY OF CYLINDER ASSEMBLY".

12. Disassemble front head from shell by tapping front head with a mallet to unseat head, and lifting straight out through rear of shell the front head and shell to head "O" ring (see Figure 11-75). Discard "O" ring.

NOTE: If teflon surfaces of front head (see Figure 11-76) are damaged, replace front head.

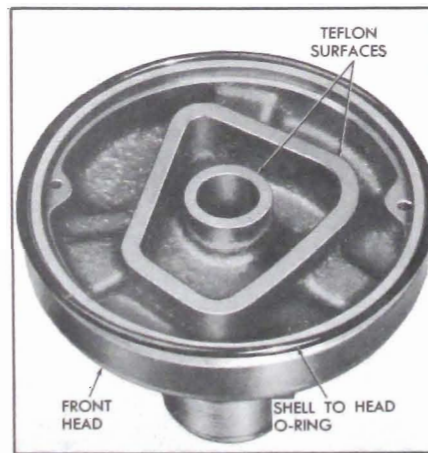

Figure 11-76—Front Head Teflon Sealing Surfaces

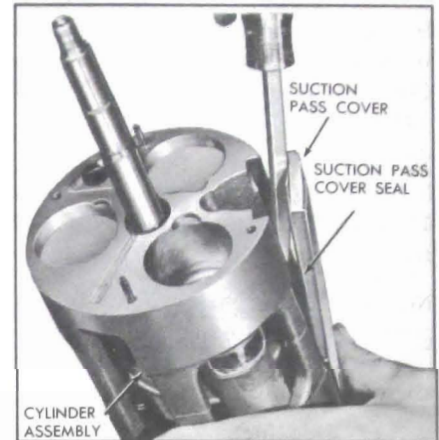

Figure 11-77—Removing Suction Pass Cover and Seal

**DISASSEMBLY OF CYLINDER ASSEMBLY**

13. Pry off suction pass cover and suction pass cover seal using screwdriver (see Figure 11-77) and discard seal.

14. Place cylinder assembly (front end downward) on top of Compressing Fixture (J-9397), number pistons and cylinders "1, 2 and 3" to facilitate reassembly (see Figure 11-78), and separate cylinder halves using a rubber mallet and wood block.

15. Disassemble rear cylinder half and discharge tube from cylinder assembly and discard discharge tube.

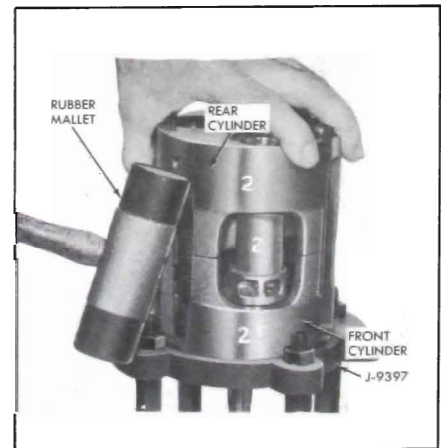

Figure 11-78—Separating Cylinder Halves

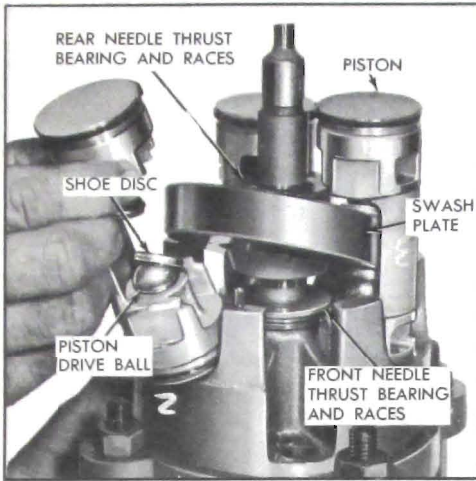

Figure 11-79—Disassembly of Cylinder Assembly

NOTE: Depending on whether or not discharge tube comes out with rear cylinder half or remains in front cylinder half--it may be necessary to rotate shaft and swash plate assembly (using 9/16 inch open end wrench on shaft seal portion of shaft) to achieve necessary clearance.

16. Carefully disassemble from cylinder assembly (see Figure 11-79) and lay in respective place of Parts Tray (J-9402) the following: number "1, 2 and 3" pistons, piston drive balls, and piston rings. To disassemble, rotate swash plate until piston is at highest point, raise swash plate approximately 1/2 inch and lift out piston and related parts one at a time. Discard shoe discs and rear needle thrust bearings and races.

NOTE: Examine piston drive balls and replace if necessary.

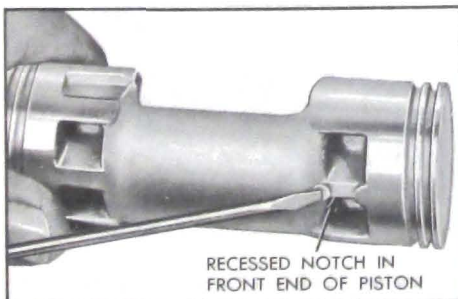

Figure 11-80—Piston Identification

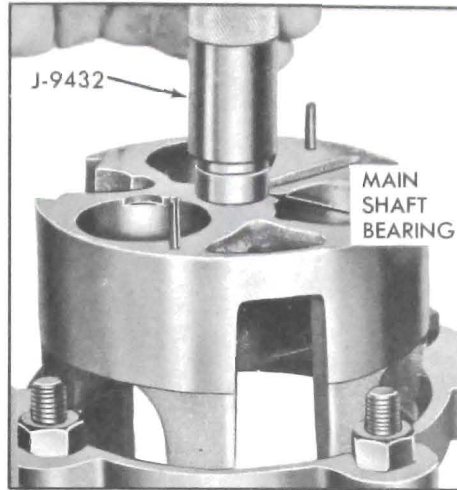

Figure 11-81—Installing Main Shaft Bearing

The front end of the piston may be identified by a recessed notch (see Figure 11-80).

17. Lift out shaft and swash plate assembly and front needle thrust bearing races. Discard front needle thrust bearing and races.

NOTE: Examine shaft and swash plate assembly and replace as necessary.

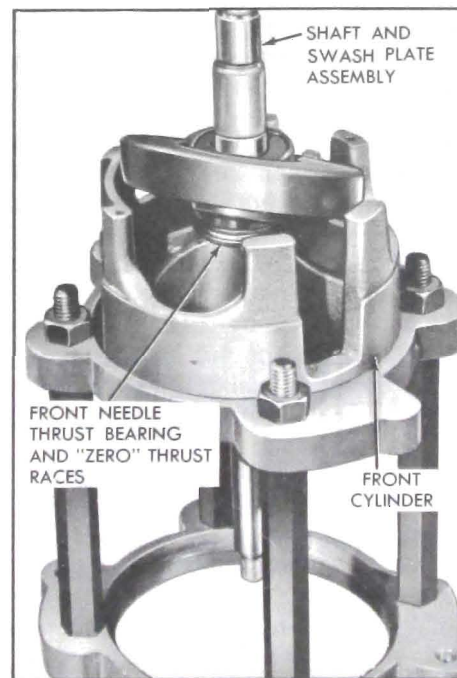

Figure 11-82—Shaft and Front Needle Thrust Bearing in Cylinder Half

18. Wash all salvaged parts of cylinder assembly in bath of trichlorethylene, alcohol, or similar solvent and dry parts with filtered, dry compressed air.

NOTE: Examine front and rear cylinder halves, front and rear main shaft bearings, and replace as necessary. If bearings are to be replaced, drive out of cylinder halves with suitable socket or punch. Install new bearing (lettering on bearing edge facing outward) using Bearing Installer (J-9432). See Figure 11-81.

PARTIAL REASSEMBLY OF CYLINDER ASSEMBLY, AND GAUGING OF PISTON PLAY AND SHAFT END PLAY

19. Procure from parts stock four "zero" thrust races, two needle thrust bearings, and three "zero" shoe discs.

20. Place front cylinder on top of Compressing Fixture (J-9397) as shown in Figure 11-82.

21. Generously coat with clean petroleum jelly two "zero" thrust races, and a new needle thrust bearing. Assemble races and bearing to front end of shaft and swash plate assembly and insert assembly into front cylinder (see Figure 11-82).

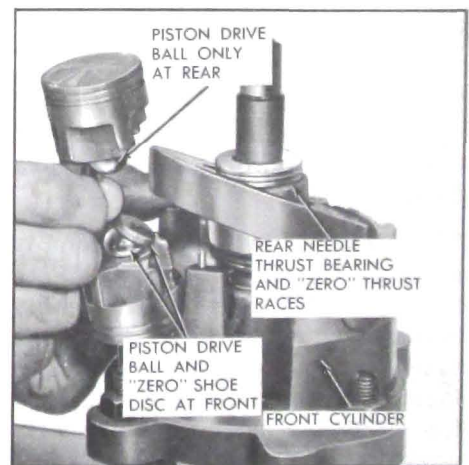

Figure 11-83—Installing Piston into Cylinder Half



22. Assemble two additional "zero" thrust races and a new needle thrust bearing to rear end of shaft and swash plate assembly.

23. Lightly coat ball pockets of the three pistons and place a piston drive ball in each pocket.

24. Lightly coat the three "zero" shoe discs with clean petroleum jelly and place a disc on only the piston drive ball at the front of each piston.

**NOTE:** Do not place shoe discs on rear piston drive balls. Do not reassemble piston rings on pistons at this time. Use lubricant in sufficient quantity so that piston drive balls and shoe discs stick to piston.

25. Rotate shaft and swash plate assembly until high point of swash plate is over No. "1" cylinder bore. Position No. "1" piston onto swash plate (see Figure 11-83) and lower the piston and swash plate so the front end (notched end--see Figure 11-80) of the piston enters the cylinder bore.

**NOTE:** In order to fit the piston onto the swash plate, the shaft and swash plate assembly must be raised approximately 1/2 inch, and also the front needle thrust bearing and races must be held up against the hub of the swash plate.

26. Repeat preceding step for reassembly of pistons No. "2" and No. "3".

27. Reassemble rear cylinder onto front cylinder using wood block and mallet (see Figure 11-84).

28. Remove cylinder assembly from on top of Compressing Fixture (J-9397), position assembly inside fixture so that discharge tube opening in cylinder halves is located between fixture legs, and front of cylinder assembly is downward. Install and torque fixture nuts to 15 lb. ft.

29. Gauge piston play as follows:

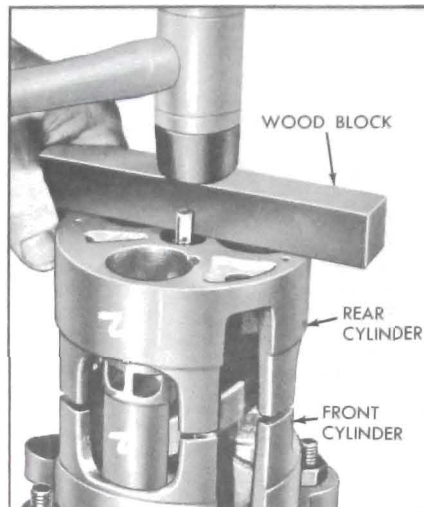

Figure 11-84—Assembling Rear Cylinder Half

(a) Using a feeler gauge, select a leaf or combination of leaves which result in satisfactory "feel" when inserted between rear piston drive ball and swash plate (see Figures 11-85 and 11-86).

(b) Remove selected leaf or leaves from feeler gauge and attach end of spring scale that is calibrated in ounces. (A Generator Brush Spring Scale (J-5184) or the spring scale or checking distributor point setting may be used for this step.)

(c) Reinsert feeler gauge leaf or leaves between rear piston drive ball and swash plate and draw

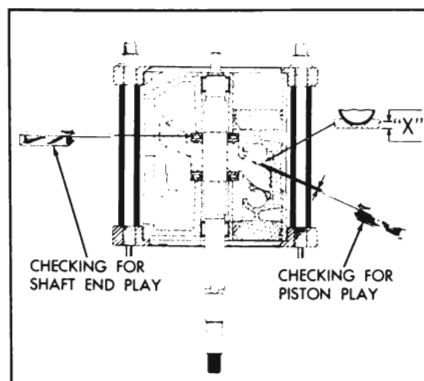

Figure 11-85—Checking Piston Play and Shaft End Play

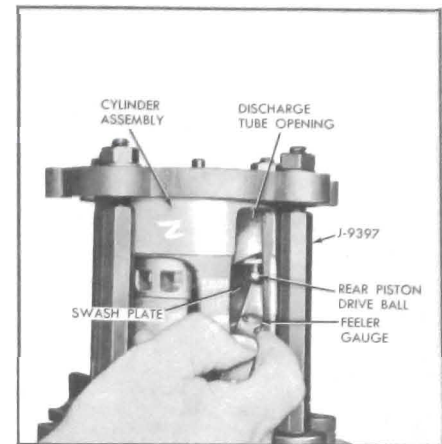

Figure 11-86—Checking Clearance Between Rear Piston Drive Ball and Swashplate

leaf or leaves out again, simultaneously measuring "drag" on leaf or leaves (see Figure 11-87). If correct leaf (leaves) has been selected, spring scale will read between 4 to 8 ounces pull (the higher reading is desired). To perform this step correctly, feeler gauge leaf (leaves) must be withdrawn straight out with a steady even motion, and all surfaces involved must be coated with No. 525 viscosity oil. Record gauge dimension.

**NOTE:** Use of the spring scale establishes a standard of measurement of the amount of feeler gauge leaf "drag" required.

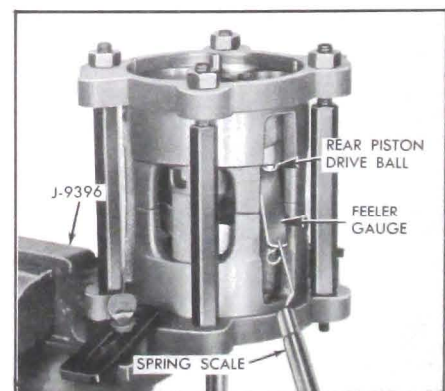

Figure 11-87—Checking "Drag" on Selected Feeler Gauge Leaf with Spring Scale

SHOE DISC CHART	
SERVICE PART NO.	IDENTIFICATION NO. STAMPED SHOE DISC
6557000	0 ("ZERO" SHOE DISC)
6556175	17½
6556180	18
6556185	18½
6556190	19
6556195	19½
6556200	20
6556205	20½
6556210	21
6556215	21½
6556220	22

Figure 11-88—Shoe Disc Table

(d) Rotate the shaft and swash plate assembly 120 degrees and perform a second check (Steps "a, b and c") between same piston drive ball and swash plate. Record gauge dimension.

(e) Rotate shaft and swash plate again approximately 120 degrees and repeat third check (Steps "a, b and c") between same piston drive ball and swash plate. Record gauge dimension.

(f) From the three recorded checks (Steps "c, d and e") select minimum feeler gauge reading and procure from stock (ref. Figure 11-88 for part number of shoe disc) one shoe disc corresponding to the minimum gauge reading (ref. example below). Place shoe disc in respective position of Parts Tray (J-9402).

**EXAMPLE**

	1st check	2nd check	3rd check
Piston #1	.019	.020	.019
	(Select No. 19 shoe disc)		
Piston #2	.020	.020	.020
	(Select No. 20 shoe disc)		
Piston #3	.021	.020	.021
	(Select No. 20 shoe disc)		

(g) Repeat Steps "c, d, e and f" for other two pistons and procure

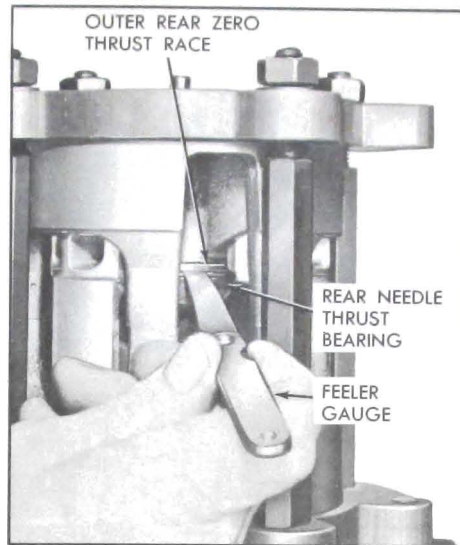

Figure 11-89—Gauging Clearance Between Rear Needle Thrust Bearing and Outer Rear Thrust Race

two more selected shoe discs for other two pistons.

**NOTE:** In the rebuilt cylinder assembly, each piston will have one selected shoe disc and one "zero" shoe disc.

30. Gauge shaft end play as follows:

(a) Using a feeler gauge, select a leaf or combination of leaves which result in satisfactory "feel" when inserted between rear needle thrust bearing and outer rear thrust race (see Figure 11-89).

(b) Remove selected leaf or leaves from feeler gauge. Attach to end of spring scale calibrated in ounces. (A Generator Brush Spring Scale (J-5184) or the spring scale for checking distributor point setting may be used for this step.)

(c) Reinsert feeler gauge leaf (leaves) between rear needle thrust bearing and outer rear thrust race and draw leaf (leaves) out again, this time simultaneously noting the "drag" or pull on the leaf (leaves) as measured by the spring scale (see Figure 11-90). If correct leaf (leaves) have been selected,

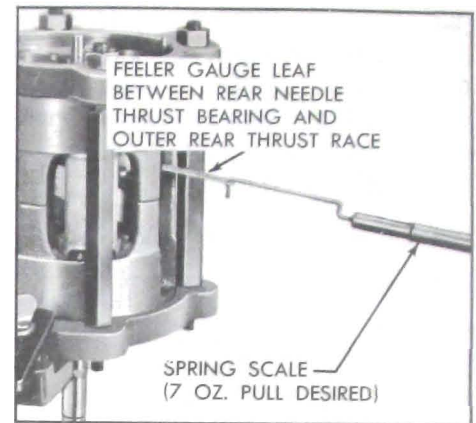

Figure 11-90—Checking "Drag" on Selected Feeler Gauge Leaf with Spring Scale

spring scale will read between 4 to 8 ounces pull (the higher reading is desired). To perform this step correctly, the feeler gauge leaf (leaves) must be withdrawn straight out with a steady, even motion. All contacting surfaces involved in gauging operation must be coated with No. 525 viscosity oil.

**NOTE:** The measurement for selection of the thrust race needs to be performed at only one place on the shaft and swash plate assembly.

(d) Select from stock one thrust race (ref. Figure 11-91 for part number of thrust race) corresponding to the feeler gauge reading determined in Step "c", and place the selected thrust race in

SERVICE PART NO.	IDENTIFICATION NO. STAMPED ON RACE
6556000	0
6556055	5½
6556060	6
6556065	6½
6556070	7
6556075	7½
6556080	8
6556085	8½
6556090	9
6556095	9½
6556100	10
6556105	10½
6556110	11
6556115	11½
6556120	12

Figure 11-91—Thrust Race Table

the parts tray slot designated for the outer rear thrust race. If, for example, a feeler gauge reading of 0.009 inch results, a thrust race with a number "9" stamped on it should be selected.

**NOTE:** The selected thrust race will replace only the "zero" outer rear thrust race. The remaining three "zero" thrust races will remain as part of the cylinder assembly.

31. Remove cylinder assembly from inside Compressing Fixture (J-9397), place on top of compressing fixture (see Figure 11-82) and disassemble rear cylinder from front cylinder using rubber mallet and wood block.

32. Carefully disassemble one piston at a time from front cylinder and lay piston, front and rear piston drive balls and front "zero" shoe disc in respective slot of Parts Tray (J-9402). To disassemble, rotate swash plate until piston is at highest point, raise swash plate approximately 1/2 inch and lift out piston and related parts, one at a time.

33. Remove outer rear "zero" thrust race from shaft and set it aside for future gauging procedures.

34. Remove previously selected outer rear thrust race from parts tray, lightly coat with clear petroleum jelly and assemble onto shaft.

#### FINAL REASSEMBLY OF CYLINDER ASSEMBLY

35. Reassemble piston rings onto pistons (ring scraper groove toward center of piston) and rotate ring so that break or gap in ring can be squeezed together when piston is being inserted into cylinder bore.

36. Reassemble piston drive balls, "zero" and selected shoe discs onto No. "1" piston, and apply clear petroleum jelly to piston pockets and shoe discs so

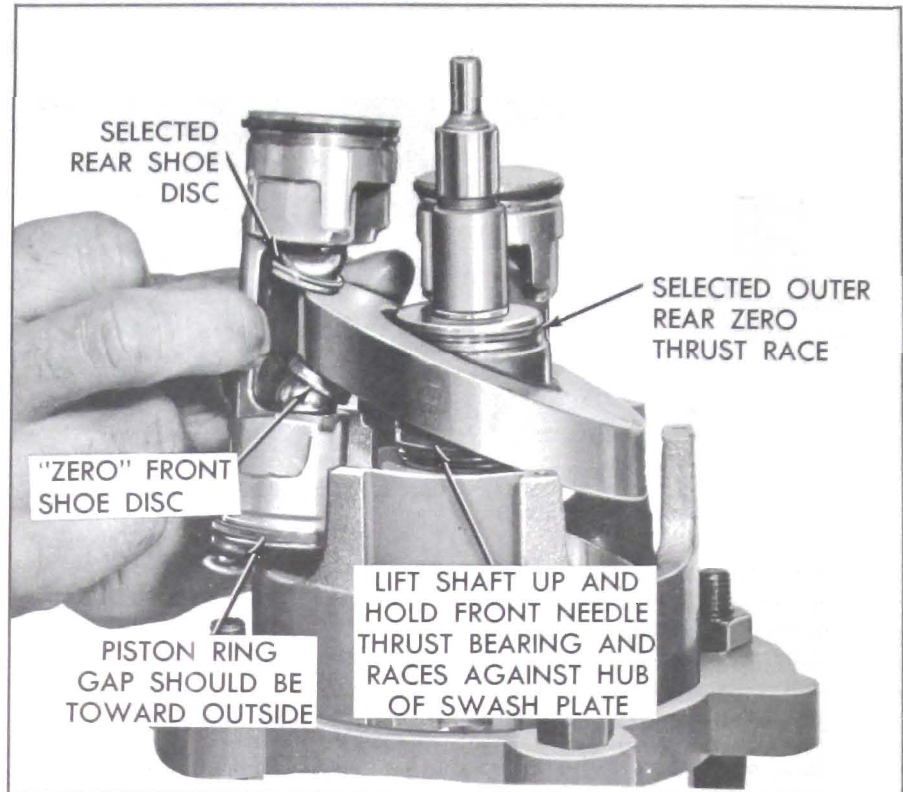

Figure 11-92—Installing Piston Assembly in Front Cylinder Half

that balls and discs stick to piston.

**NOTE:** Be sure to reassemble balls and shoe discs into their specific positions on front and rear of piston.

37. Rotate shaft and swash plate assembly until high point of swash plate is over No. "1" cylinder bore. Position No. "1" piston onto swash plate (see Figure 11-92) and lower the piston and swash plate so that the front end (notched end) of the piston enters the cylinder bore.

**NOTE:** In order to fit the piston onto the swash plate and into the cylinder bore, the swash plate must be raised approximately 1/2 inch, the front needle thrust bearing and races must be held up against the hub of the swash plate, and the piston rings must be squeezed together (see Figure 11-93). Lubricate cylinder bore, piston assembly and swash plate

with No. 525 viscosity oil to facilitate reassembly.

38. Repeat procedure in Steps 36 and 37 for installation of No. 2 and No. 3 pistons.

39. Obtain new service replacement discharge tube and assemble

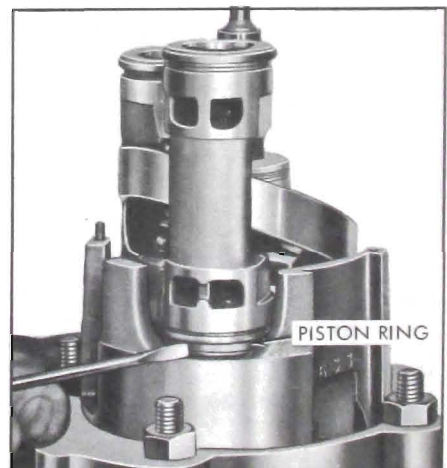

Figure 11-93—Compressing Front Piston Rings

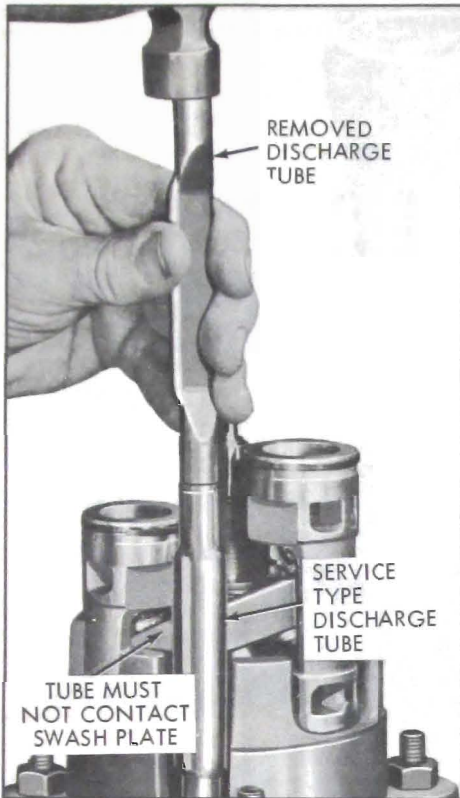

Figure 11-94—Installing Service Type Discharge Tube

into front cylinder (see Figure 11-94).

40. Liberally lubricate cylinder bores of rear cylinder and reassemble rear cylinder onto front cylinder being sure to compress piston rings. Align discharge tube and dowel pins, and tap cylinder halves together. Check for free rotation of shaft.

**NOTE:** If pistons are positioned in a "stair-step" arrangement (see Figure 11-95), installation of rear cylinder will be facilitated. In addition once the piston and ring are started into the cylinder, slight rotation of the shaft to and fro will work the ring into the bore.

41. Liberally lubricate with No. 525 viscosity oil, suction pass cover seal and lips of suction passage in body of cylinder assembly, and reassemble suction pass cover and seal over suction



Figure 11-95—Pistons Position In "Stair-Step" Arrangement

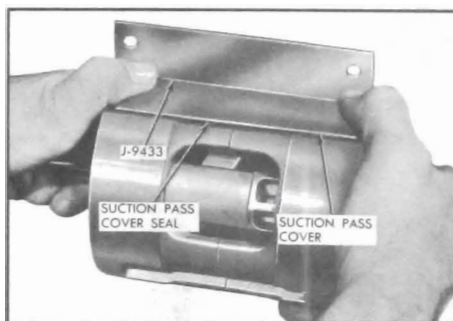

Figure 11-96—Installing Suction Pass Cover and Seal

passage (see Figures 11-96 and 11-97) using Seal Installer (J-9433).

**NOTE:** Use Seal Installer (J-9433) as a shoe horn and snap cover into place.

42. Assemble both service replacement discharge tube "O" rings and bushings (see Figure 11-98) onto cylinder assembly.

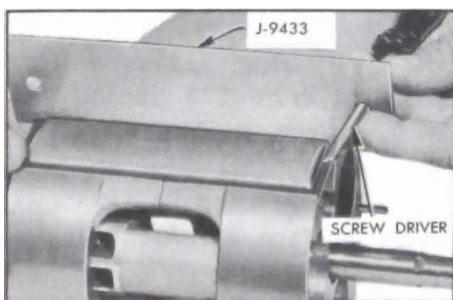

Figure 11-97—Removing Installer J-9433

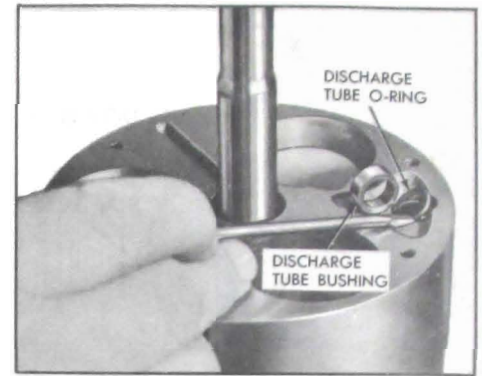

Figure 11-98—Installing Discharge Tube O-Ring and Bushing

**REASSEMBLY OF FRONT SUCTION VALVE REED DISC, FRONT DISCHARGE VALVE PLATE, FRONT HEAD, AND INSTALLING OF CYLINDER ASSEMBLY**

43. Assemble suction reed valve disc to front of cylinder assembly and align with dowel pins, suction port and discharge port (see Figure 11-99).

44. Assemble front discharge valve plate to front of cylinder assembly and align with dowel pins.

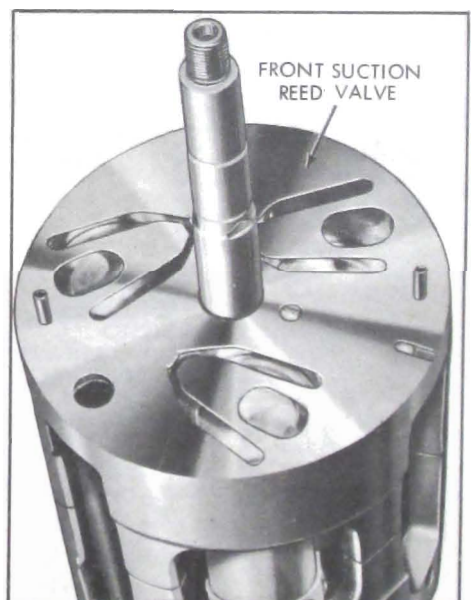

Figure 11-99—Front Suction Valve Reed Disc Installed

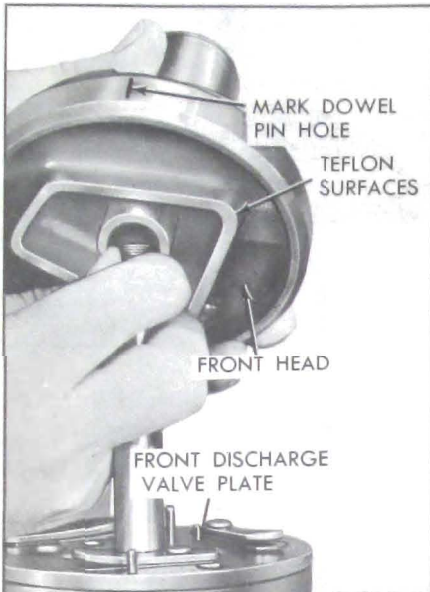

Figure 11-100—Placing Front Head on Cylinder Assembly

45. Coat teflon surfaces on front head (see Figure 11-100) with No. 525 viscosity oil.

46. Mark with pencil on side of front head the location of dowel pin holes (see Figure 11-100),



Figure 11-101—Shell to Head O-Ring Installation

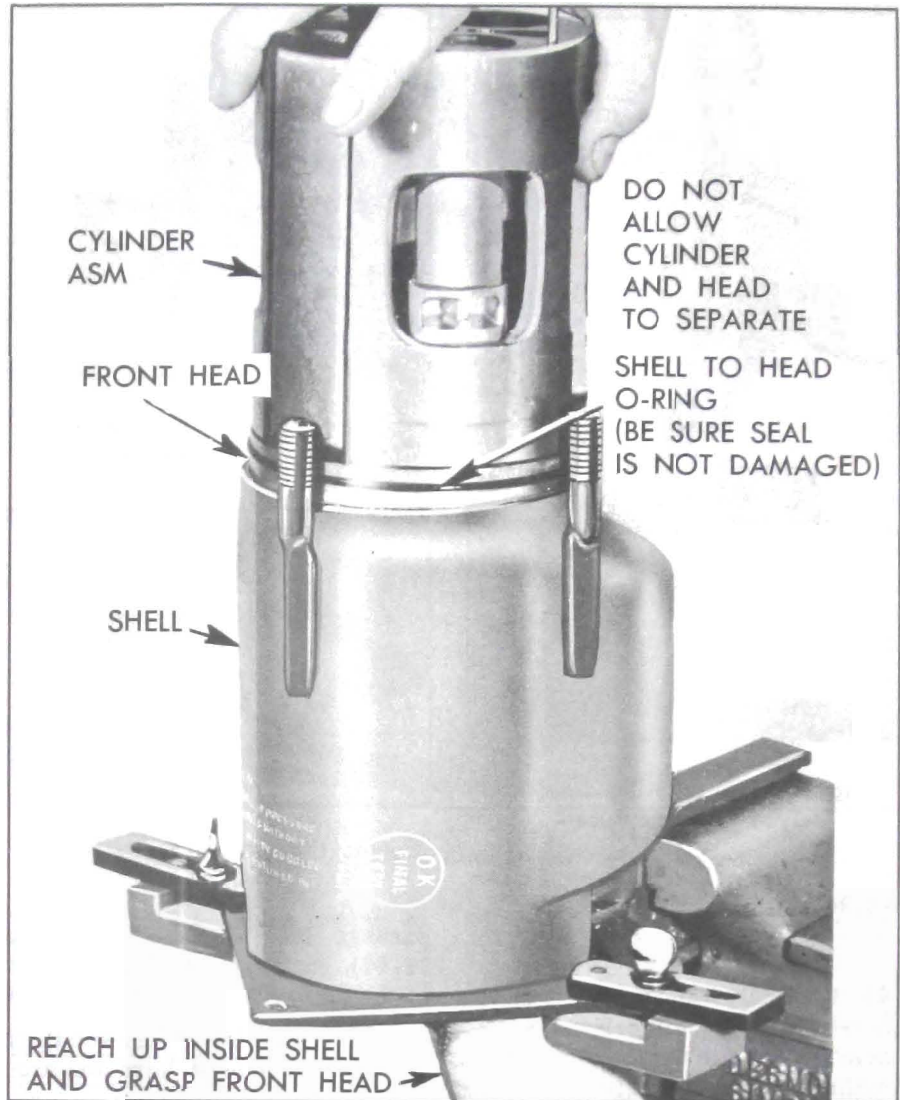

Figure 11-102—Installing Cylinder Assembly and Front Head in Shell

align front head with dowel pins, and tap head lightly with mallet to seat on cylinder assembly.

47. Place new shell to head "O" ring on shoulder of front head (see Figure 11-101) and liberally coat "O" ring and front head surface with No. 525 viscosity oil.

48. Install shell in Holding Fixture (J-9396) and position so that rear studs of shell are up. Coat inside surface of shell with No. 525 viscosity oil.

49. Reassemble as a unit cylinder assembly and front head into the shell (see Figure 11-102).

**NOTE:** Extreme care must be used to prevent shell to head "O" ring seal from being damaged.

**REASSEMBLY OF REAR SUCTION VALVE REED DISC, REAR DISCHARGE VALVE PLATE, OIL PUMP AND REAR HEAD**

50. Rotate the cylinder assembly and front head until the hole for the oil inlet tube in the cylinder assembly is aligned with the reservoir hole in the shell, and reassemble the oil inlet tube and "O" ring.



Figure 11-103—Positioning Oil Pump Outer Rotor

51. Assemble suction reed valve disc to rear of cylinder assembly and align with dowel pins, suction

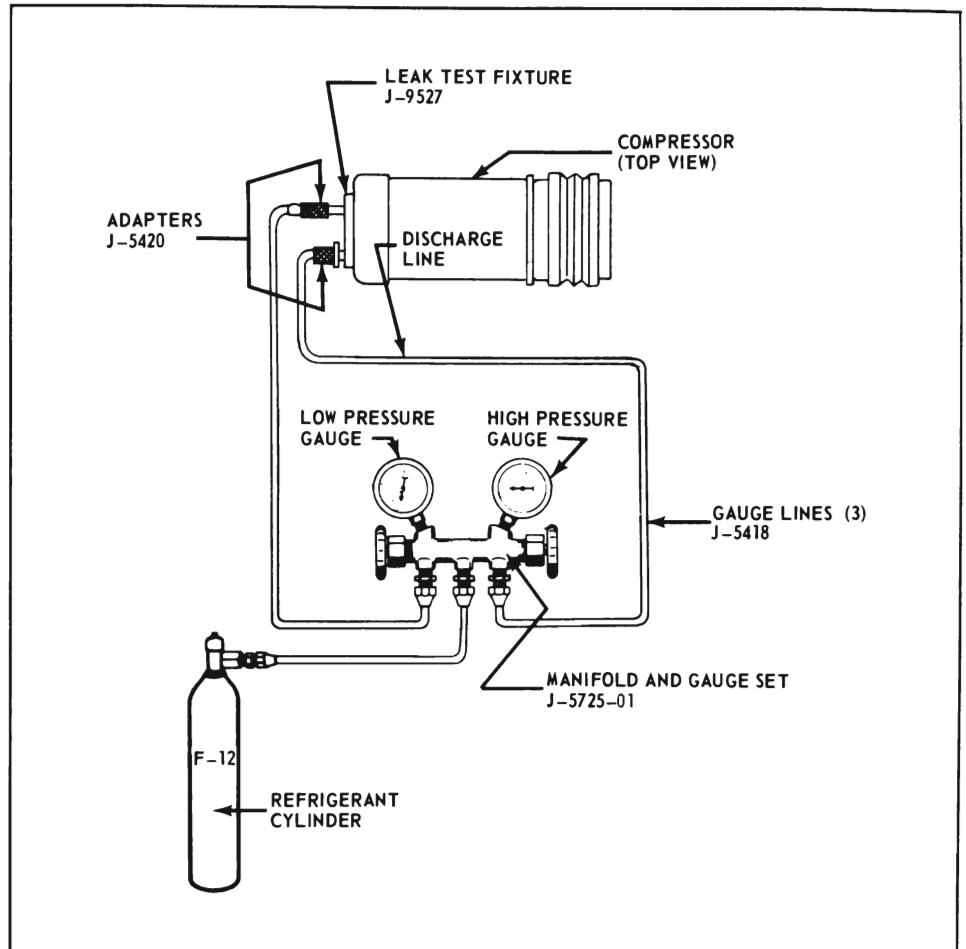

Figure 11-105—Compressor Internal Leak Test

port, and discharge port of cylinder assembly.

52. Assemble rear discharge valve plate to rear of cylinder assembly and align with dowel pins.

53. Reassemble inner and outer oil pump rotors so that the sides previously identified are in their original location, and then position oil pump outer rotor as shown in Figure 11-103.

54. Generously coat with No. 525 viscosity oil new shell to head "O" ring and install in shell (see Figure 11-103).

55. Coat teflon surfaces of rear head with No. 525 viscosity oil, mark with pencil on side of rear head the location of the dowel pin holes and reassemble onto compressor.

**NOTE:** It may be necessary to reposition oil pump outer rotor slightly in order to install rear head. In addition, if dowel pins do not engage holes in rear head, grasp front head and rotate cylinder assembly slightly (see Figure 11-104).

56. Assemble new nuts to threaded shell studs and torque to 20 lb. ft.

**NOTE:** If pressure relief valve has been removed, reassemble using a new pressure relief valve gasket.

57. Reassemble new lubricated suction and discharge "O" rings into suction and discharge ports of rear head.

58. Reassemble shaft seal onto front of shaft and swash plate assembly (ref. subpar. "i").



Figure 11-104—Installing Rear Head

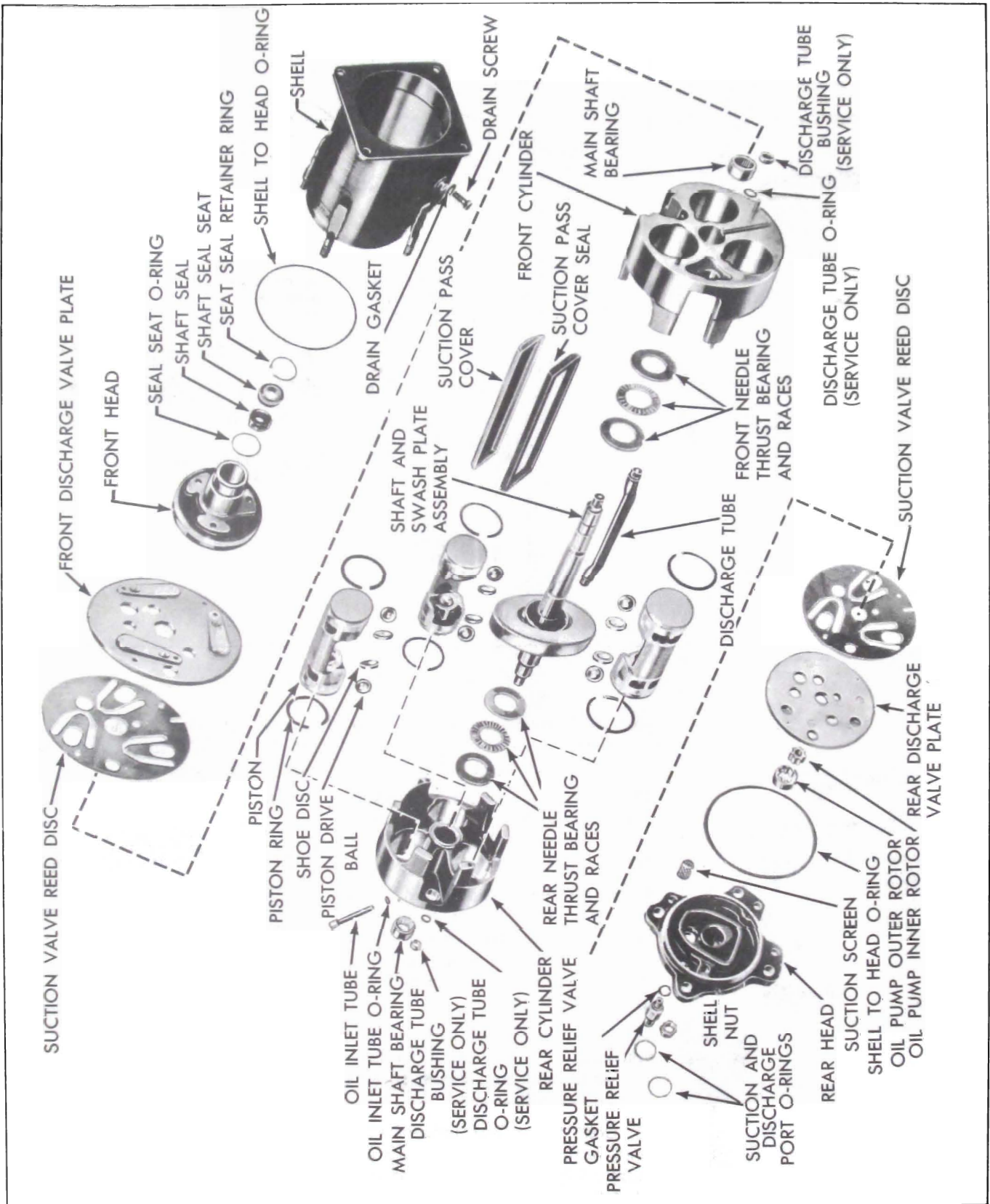

Figure 11-106—Compressor (Exploded View)

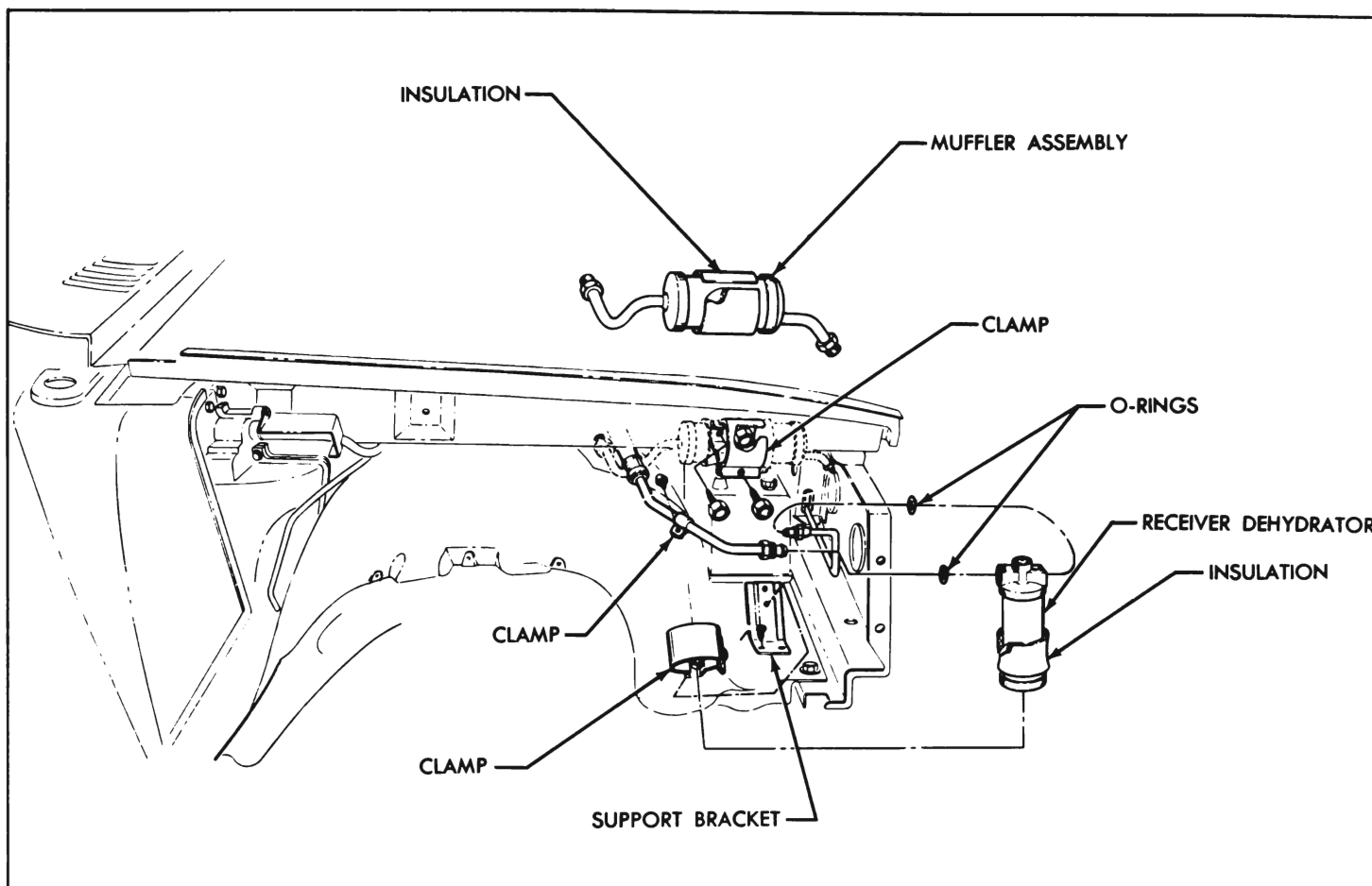

Figure 11-107—Muffler and Receiver - Dehydrator Installation

**NOTE:** Do not reassemble clutch drive plate at this time.

**LEAK TESTING COMPRESSOR**

59. After the shaft seal pressure test (ref. subpar. "i") has been performed, change the test circuit to the configuration shown in Figure 11-105.

60. Pressurize only discharge side (refrigerant cylinder at room temperature) of compressor by opening cylinder valve, lower pressure gauge valve and high pressure gauge valve. If the same pressure is noted on the discharge high pressure gauge as on the low pressure gauge--an internal leak exists. Correct leak as necessary.

**NOTE:** If internal leak exists, leak may exist in sealing surface of teflon seal, discharge tube,

shell to head "O" rings, or suction valve reed discs.

61. Close high pressure gauge valve and observe if high pressure gauge drops more than 10 pounds in 30 seconds. Indication of this also evidences an internal leak. Correct leak as necessary.

62. Remove drain screw from shell and add No. 525 viscosity oil as specified in subparagraph "f".

63. Reassemble pulley assembly, and coil and housing assembly onto hub of front head (ref. subpar. "j").

64. Complete reassembly by installing clutch drive plate onto hub of front head (ref. subpar. "i").

**I. Removal and Installation of Muffler**

**REMOVAL**

1. Discharge system (ref. subpar. "e").
2. Remove battery.
3. Disconnect refrigerant lines connected to muffler (see Figure 11-107) and tape closed both open ends of refrigerant lines and both ends of muffler.
4. Remove two screws holding muffler clamp to inner portion of fender and lift out muffler and clamp, and disassemble as required.

**INSTALLATION**

5. Install muffler reverse of removal, using new "O" rings during installation coated with No. 525 viscosity oil.



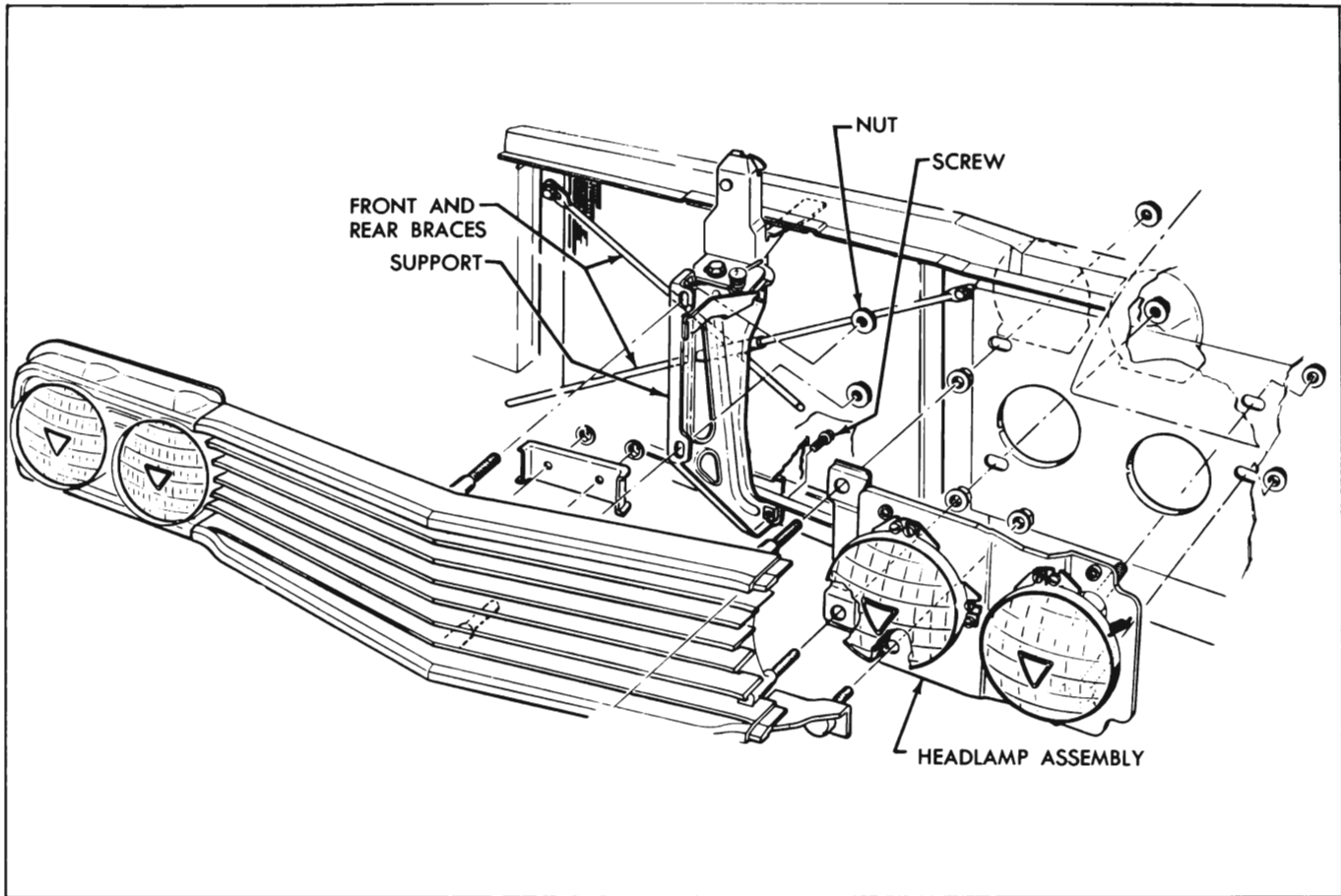

Figure 11-108—Front End and Headlamp Installation

NOTE: If refrigerant circuit or muffler has been exposed to the atmosphere for any amount of time and moisture may be present in the circuit, flush the muffler or system as necessary (ref. subpar. g). Install a new receiver-dehydrator in system.

6. Charge the system (ref. subpar. s).

#### m. Removal and Installation of Condenser

##### REMOVAL

1. Discharge system (ref. subpar. "e").
2. Disconnect inlet and outlet pipes of condenser (see Figure 11-28) and tape closed both open ends of refrigerant lines, and also

the open ends of the inlet and outlet pipes of the condenser.

3. Remove one bolt securing each cross brace (see Figure 11-108) to the radiator baffle and position front and rear braces out of way.

4. Remove five screws and take out grille support.

5. Remove screws holding right and left flanges of condenser to radiator baffle and remove condenser.

##### INSTALLATION

6. Install condenser reverse of removal and use new "O" rings during installation. Lubricate "O" rings prior to installation using No. 525 viscosity oil.

NOTE: If refrigerant circuit or condenser has been exposed to the

atmosphere and moisture may be present in circuit, the system and/or component must be flushed prior to installation (ref. subpar. "g").

7. Charge the refrigerant circuit (ref. subpar. "s").

#### n. Removal and Installation of Receiver-Dehydrator

##### REMOVAL

1. Discharge system (ref. subpar. "e").
2. Remove battery.
3. Disconnect refrigerant lines to both ends of receiver-dehydrator (see Figure 11-107) and tape closed both open ends of refrigerant lines, and also the open ends of the inlet and outlet pipes of the receiver-dehydrator.

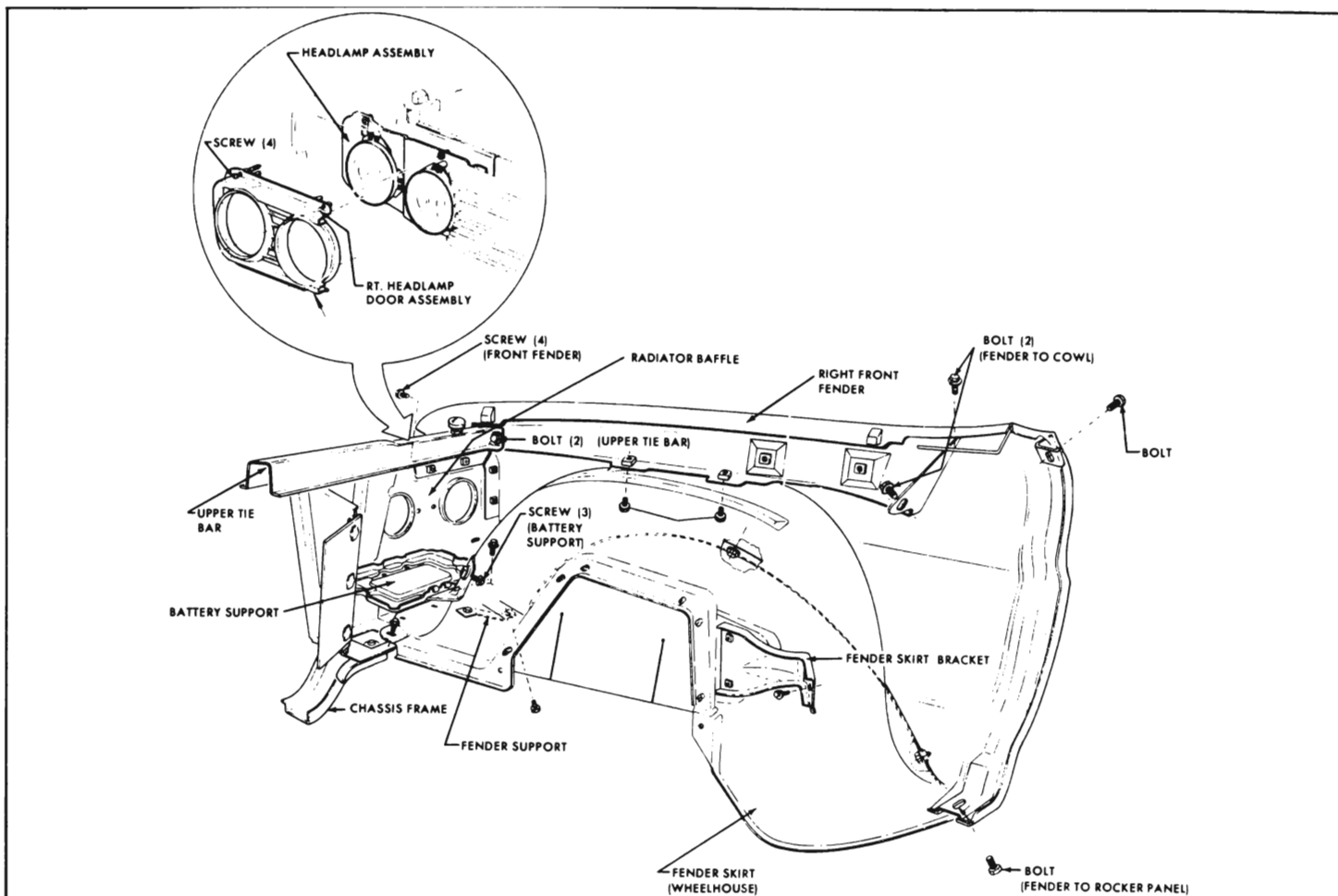

Figure 11-109—Right Front Fender Installation

4. Remove two screws securing receiver-dehydrator and clamp to support bracket and lift out receiver-dehydrator.

#### INSTALLATION

5. Install receiver-dehydrator reverse of removal and use new "O" rings during installation. Lubricate "O" rings with No. 525 viscosity oil prior to installation.

NOTE: If the receiver-dehydrator has been exposed to the atmosphere for any amount of time, the receiver-dehydrator should be replaced, since the life of desiccant is probably expended.

6. Charge refrigerant circuit (ref. subpar. "s").

#### o. Removal and Installation of Expansion Valve

##### REMOVAL

1. Remove right front fender and skirt as follows:

(a) Unscrew four screws securing right headlamp door assembly (see Figure 11-109) to headlamp assembly.

(b) Remove four screws securing front fender to radiator baffle.

(c) Remove battery, unscrew two screws securing battery support to radiator baffle, and two screws securing battery support to fender skirt (wheelhouse), and lift out battery support.

(d) Discharge refrigerant circuit (ref. subpar. "e").

(e) Disconnect lines to muffler and receiver-dehydrator, tape

closed open lines, and also both openings in muffler and receiver-dehydrator.

(f) Unfasten all electrical wires attached to fender skirt.

(g) Remove one bolt and five screws securing front of fender skirt to radiator baffle.

(h) Remove two bolts securing front of fender to upper tie bar.

(i) Remove two bolts securing upper rear portion of fender to cowl.

(j) Remove one bolt securing rear edge of fender to inner portion of door jamb.

(k) Remove one bolt securing lower rear edge of fender to rocker panel.

(l) Rest a 2 x 4 inch board across cowl and radiator, and position board to support hood. Remove

two bolts holding hood hinge to fender.

(m) Remove one bolt which secures fender skirt bracket to cowl.

(n) Disconnect antenna lead (if so equipped) from radio.

(o) Raise up and lift off fender and skirt, and withdraw antenna lead.

2. Disconnect expansion valve capillary tube bulb attached to the outlet pipe of the evaporator. (See Figure 11-41).

3. Disconnect the equalizer line from the body of suction throttling valve. (See Figure 11-38). Tape closed equalizer line port on suction throttling valve, and also open end of equalizer line.

4. Disconnect inlet and outlet ends of expansion valve from refrigerant circuit, and tape closed open ends of refrigerant lines and inlet and outlet ports of expansion valve.

5. Remove lower clamp of bracket securing expansion valve and suction throttling valve to plenum blower and air valve assembly and lift out expansion valve.

#### INSTALLATION

6. Install expansion valve reverse of removal, and use new "O" rings during installation. Lubricate "O" rings prior to installation using No. 525 viscosity oil.

NOTE: If expansion valve or refrigerant lines have been exposed to the atmosphere for any amount of time and moisture may have entered the valve or the system, flush the system or valve as necessary (ref. subpar. "g").

7. Install new receiver-dehydrator.

8. Charge system (ref. subpar. "s").

NOTE: Due to the possible adjustment difficulties involved if

the expansion valve is disassembled, disassembly of the valve is not recommended. The valve may be cleaned by submerging it in a bath of trichlorethylene, alcohol, or similar solvent. Dry by blowing filtered compressed air through the outlet port of the valve. The filter screen at the inlet port may be replaced. Remove screen by threading a 10-32 NF screw into old filter screen. With a washer and a nut on the screw arranged to work as a puller screw, hold the body of the screw and turn the nut. Insert the new filter screen into the inlet port and lightly tap screen only enough to seat.

#### p. Removal and Installation of Evaporator

##### REMOVAL

1. Remove right front fender and skirt as follows:

(a) Unscrew four screws securing right headlamp door assembly (see Figure 11-109) to headlamp assembly.

(b) Remove four screws securing front fender to radiator baffle.

(c) Remove battery, unscrew two screws securing battery support to radiator baffle, and two screws securing battery support to fender skirt (wheelhouse), and lift out battery support.

(d) Discharge refrigerant circuit (ref. subpar. "e").

(e) Disconnect lines to muffler and receiver-dehydrator, tape closed open lines, and also both openings in muffler and receiver-dehydrator.

(f) Unfasten all electrical wires attached to fender skirt.

(g) Remove one bolt and five screws securing front of fender skirt to radiator baffle.

(h) Remove two bolts securing front of fender to upper tie bar.

(i) Remove two bolts securing upper rear portion of fender to cowl.

(j) Remove one bolt securing rear edge of fender to inner portion of door jamb.

(k) Remove one bolt securing lower rear edge of fender to rocker panel.

(l) Rest a 2 x 4 inch board across cowl and radiator and position board to support hood. Remove two bolts holding hood hinge to fender.

(m) Remove one bolt which secures fender skirt bracket to cowl.

(n) Disconnect antenna lead (if so equipped) from radio.

(o) Raise up and lift off fender and skirt, and withdraw antenna lead.

2. Remove eight screws securing front and rear halves of duct between evaporator, and plenum blower and air door assemblies (see Figure 11-110). Remove front half of duct by pushing it down under the evaporator pipes. Remove rear half in a similar manner.

3. Disconnect oil bleed line from suction throttling valve (see Figure 11-38) and capillary tube bulb from outlet pipe of evaporator (see Figure 11-41). Tape closed openings in valve and line.

4. Disconnect suction throttling valve and expansion valve from evaporator outlet and inlet pipes. Tape closed all connection openings.

5. Remove five stamped screws from studs of air conditioner heater assembly (see Figure 11-110).

6. Remove glove box, disconnect air conditioner outlet hoses from distributor duct (see Figure 11-111). Remove two screws securing duct to heater assembly and take out distributor duct.

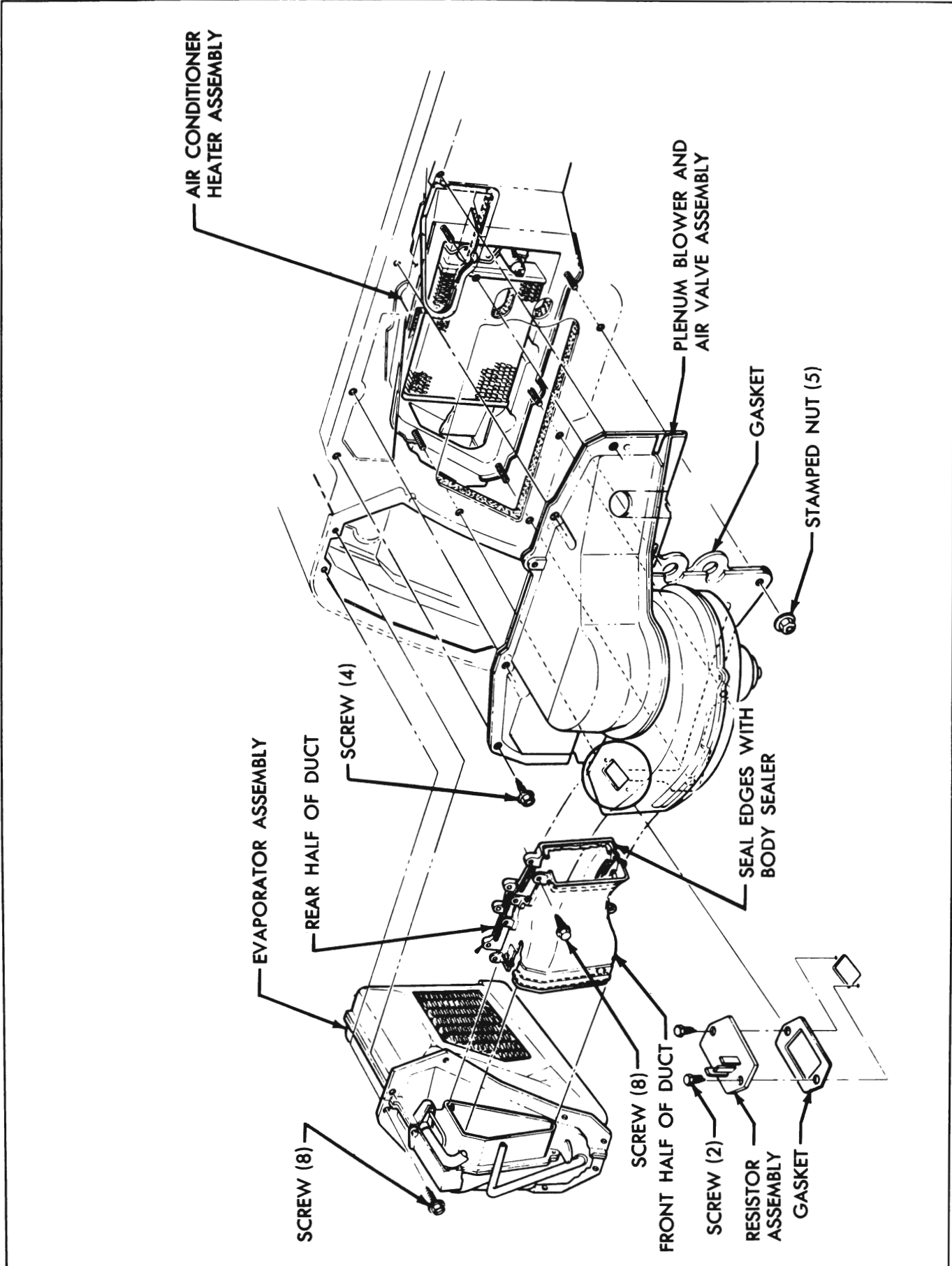

Figure 11-110—Evaporator Assembly, and Plenum Blower and Air Valve Assembly Installation

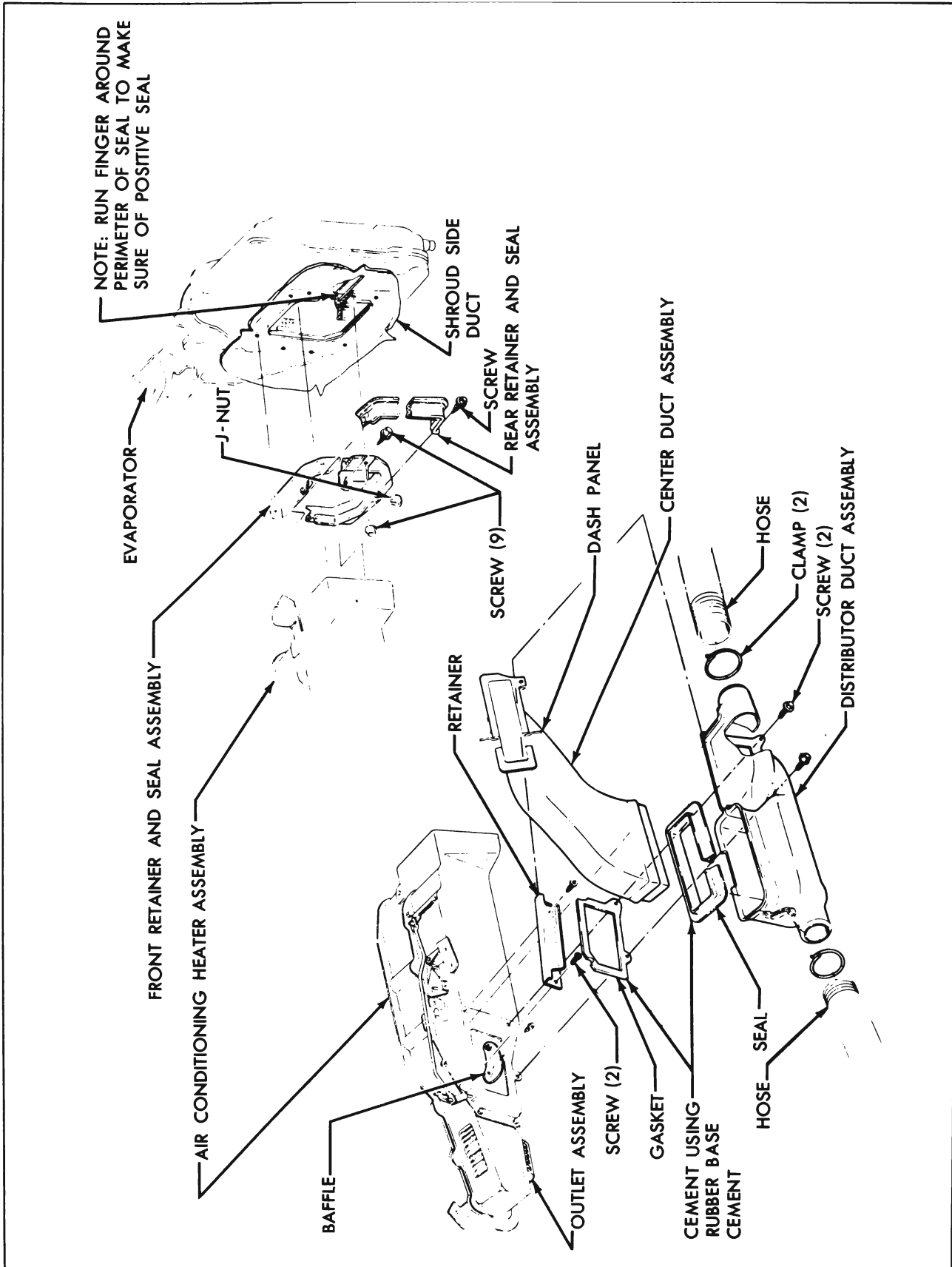

Figure 11-111—Distributor Duct Assembly, and Front Retainer and Seal Installation

7. Disconnect temperature, diverter, and defroster control wires (see Figure 11-19). Remove rear retainer and seal assembly (see Figure 11-111) and pull out air conditioner heater assembly.

8. Remove eight screws securing evaporator to cowl and pull out evaporator.

**INSTALLATION**

9. Install evaporator reverse of removal and charge system (ref. subpar. "s").

NOTE: It is recommended that a rubber lubricant be used to assist in effecting a good seal between side of evaporator and front seal. After evaporator is reassembled to the cowl, reposition front edge of rubber seal on front retainer and seal assembly so that a proper seal is created. Poor sealing action may seriously affect system performance.

**q. Removal and Installation of Suction Throttling Valve**

**REMOVAL**

1. Discharge system (ref. subpar. "e").

2. Disconnect evaporator oil bleed line from body of suction throttling valve (see Figure 11-38) and tape closed opening on suction throttling valve and evaporator oil bleed line.

3. Disconnect equalizer line from the body of the suction throttling valve. Tape closed the equalizer line port on suction throttling valve, and also open end of equalizer line.

4. Disconnect inlet and outlet ports of valve from refrigerant lines, and tape closed inlet and outlet ports. Also tape closed both refrigerant line openings.

5. Disconnect vacuum tube from vacuum diaphragm.

6. Remove lower clamp of bracket securing expansion valve and suction throttling valve to plenum blower and air door assembly, and lift out suction throttling valve.

**INSTALLATION**

7. Install suction throttling valve reverse of removal procedure using new "O" rings during installation. Lubricate "O" rings

prior to installation with No. 525 viscosity oil.

NOTE: If suction throttling valve or refrigerant lines have been exposed to the atmosphere for any amount of time, and moisture may have entered the valve or system, flush system or valve as required (ref. subpar. "g").

8. Charge system (ref. subpar. "s").

**r. Disassembly, Reassembly and Adjustment of Suction Throttling Valve**

**DISASSEMBLY**

1. Loosen lock nut and unscrew and separate vacuum diaphragm (see Figure 11-112) and outer spring from suction throttling valve.

NOTE: Due to spring tension of the outer spring, care should be exercised when separating vacuum diaphragm from valve body.

2. Remove five screws securing diaphragm cover to valve body and disassemble diaphragm cover, retainer cup and piston assembly from valve body.

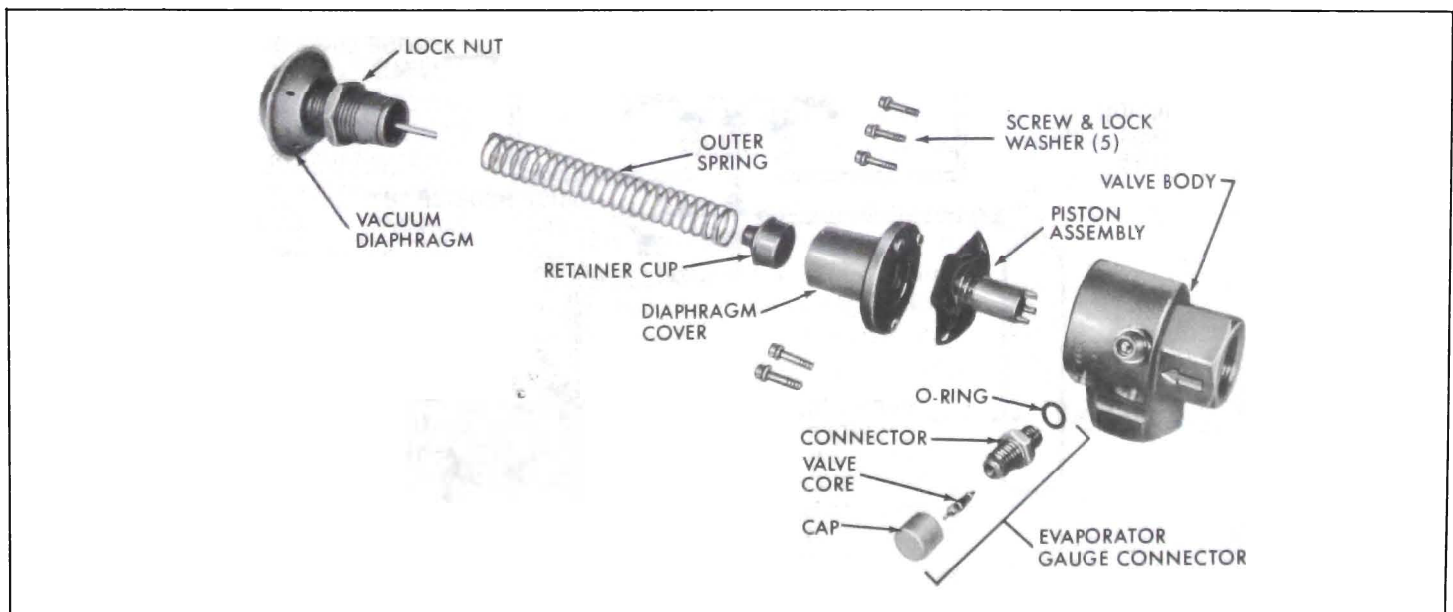

Figure 11-112—Suction Throttling Valve (Exploded View)

NOTE: Do not disassemble screen diaphragm or piston from piston assembly. Exercise care not to pinch or otherwise damage rubber diaphragm portion of piston assembly. Clean assembly by submerging in solution of trichlorethylene, alcohol or similar solvent.

3. Unscrew evaporator gauge connector from valve body and disassemble cap, valve core and "O" ring from connector.

4. Unscrew bleed connector from valve body and separate cap, valve core and "O" ring from connector.

NOTE: Due to close tolerances involved, repair of damaged parts of suction throttling valve is not recommended. Replace all un-serviceable parts.

REASSEMBLY

5. Reassemble reverse of disassembly procedure, the evaporator gauge connector and bleed connector onto valve body.

6. Lightly coat rubber diaphragm portion of piston assembly with Molykote Type Z powder. Coat only the outer side (side nearest vacuum diaphragm) of the rubber diaphragm using Molykote Type Z

(Alpha-Molykote Corporation, Stamford, Connecticut). No other powder is recommended.

7. Lightly coat inside of valve body with No. 525 viscosity oil and reassemble and hold together piston assembly, retainer cup and diaphragm cover onto valve body. Do not install screws at this time.

8. Press a finger into the inlet port and push the piston upward into the valve body. This action will force the rubber diaphragm to form inside the diaphragm cover, and thereby take up the excess rubber allowing the diaphragm cover to be seated on the valve body.

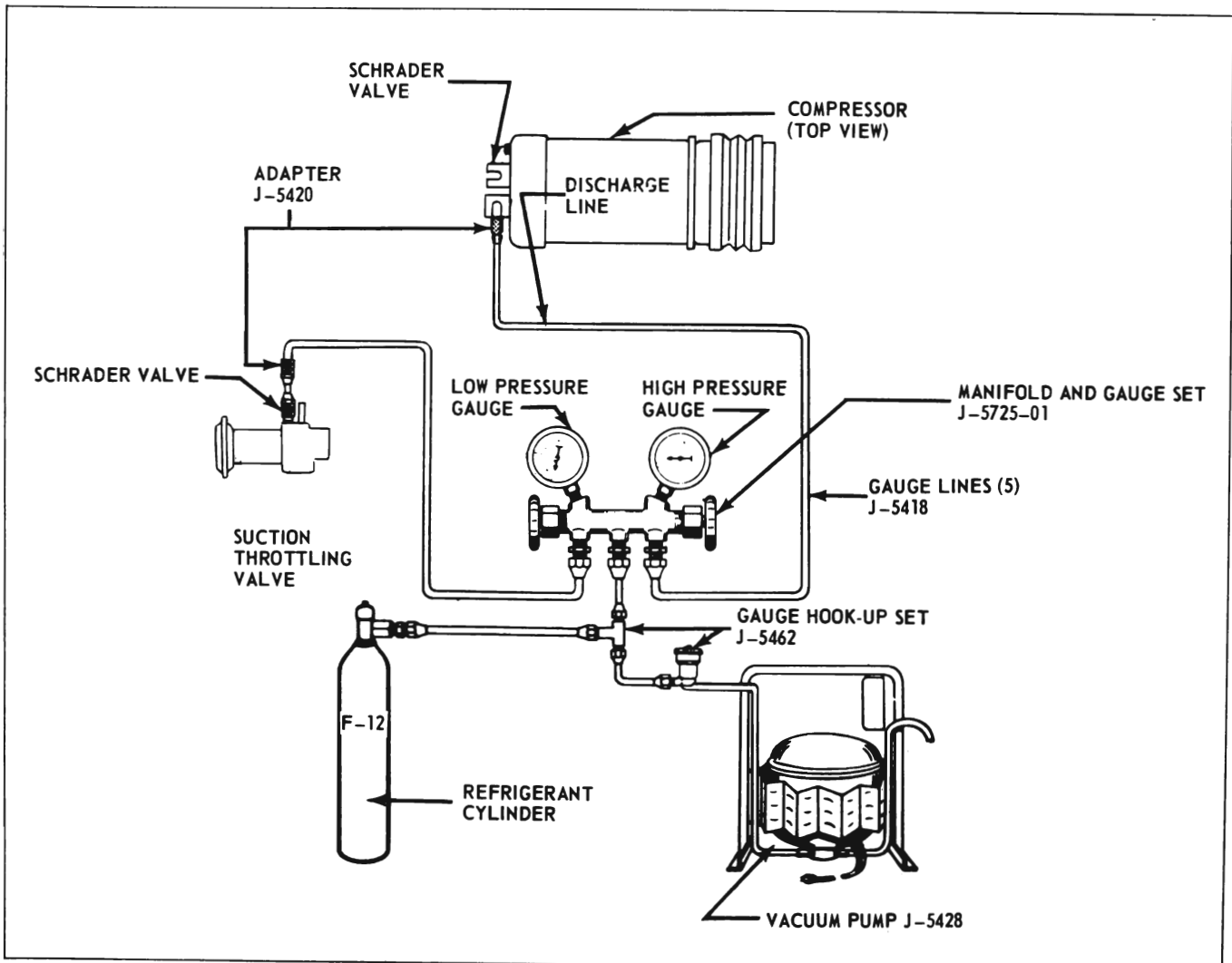

Figure 11-113—Charging Air Conditioner System

9. Once the rubber diaphragm has formed inside the diaphragm cover, press the retainer cup down several times from the opposite end of the assembly. This action will insure that the piston will seat against the inner shoulder of the body.

10. Reassemble five screws and torque 45-50 lb. inches.

11. Reassemble outer spring, washer, lock nut and vacuum diaphragm onto assembly and turn vacuum diaphragm approximately ten turns into diaphragm cover.

#### ADJUSTMENT

12. Reinstall suction throttling valve in car and perform functional tests as described in subparagraph "c".

13. If adjustment of the suction throttling valve is required, rotate vacuum diaphragm clockwise to increase suction throttle valve (low pressure gauge) pressure, and counterclockwise to decrease suction throttle valve pressure.

14. Move temperature lever from COLD to MED position and note an increase in suction throttling valve pressure of approximately 3 psi.

NOTE: If a pressure increase is not noted, check for proper operation of the suction throttling valve vacuum disc switch located on the heater and defroster control assembly, loose vacuum hose connections or kinked vacuum hoses. If these checks do not correct the problem, the difficulty is in the suction throttling valve vacuum diaphragm. Repair valve as necessary.

15. Tighten lock nut on vacuum diaphragm.

#### s. Charging System

Charging of air conditioner system consists essentially of evacuating the system, checking for leaks, primary charging, final

evacuation and final charging of system. Proceed as follows:

NOTE: A portable air conditioner service station unit (J-8393) is available for air conditioner servicing. The unit provides a means of measuring refrigerants without the use of scales and heating of the refrigerant cylinder. Due to the fact that complete instruction on use of the service station are contained on the unit, the information will not be repeated here.

1. Remove protective cap from Schrader valve located on suction throttling valve, and Schrader valve located on discharge port of compressor.

2. Interconnect vacuum pump (J-5428), Manifold and Gauge Set (J-5225-01), Gauge Hook-Up Set (J-5462), Gauge Adapters (J-5420), five Gauge Charging Lines (J-5418) and refrigerant-12 cylinder with air conditioner system (see Figure 11-113). Be sure all valves are closed.

3. Start vacuum pump and open both high and low pressure valves on manifold and gauge set. Slowly open shut-off valve of gauge hook-up set.

NOTE: If shut off valve is opened too quickly, oil may be forced out of vacuum pump.

4. Operate pump until at least 28 inches of vacuum (at sea level) registers on the low pressure gauge of the manifold and gauge set and operate vacuum for 10 minutes at or below this vacuum level. Stop vacuum pump, close shut-off valve and observe that vacuum does not drop more than 2 inches in 5 minutes.

NOTE: Allowance should be made for elevation when obtaining a vacuum. Compute vacuum level to be obtained by subtracting 1 inch of vacuum for each 1000 feet of elevation above sea level.

If 28 inches of vacuum (sea level) cannot be obtained, or if vacuum

drop with vacuum pump off is more than 2 inches in 5 minutes, then open cylinder valve to charge system at ambient cylinder pressure. Close cylinder valve, test the system for leaks using appropriate equipment (ref. subpar. "d"), and correct any leaks found. Repeat preceding step 4.

5. Primary charge system at ambient cylinder pressure by opening cylinder valve.

6. Final evacuate system by closing cylinder valve, starting vacuum pump, and slowly opening shut-off valve. Maintain 28 inches of vacuum for 10 minutes and then close shut-off valve and stop vacuum pump.

7. Close high pressure valve on manifold and gauge set.

8. Place cylinder in a bucket of water which does not exceed 125°F. Weigh cylinder and bucket of water, and record weight.

CAUTION: Never heat cylinder above 125°F. as dangerous hydrostatic pressures result in cylinder. When there is danger of cylinder overheating, a suitable pressure relief valve should be connected into the circuit. It may be necessary to reheat the water during charging operation to maintain proper temperature.

9. Open cylinder valve, idle engine and operate compressor until 3 1/2 lbs. of refrigerant-12 have been charged into the system.

NOTE: It may be necessary to move temperature lever on instrument panel from OFF to MED positions approximately 12 times to normalize the piston diaphragm in the suction throttling valve.

10. Close valve on refrigerant-12 cylinder, low pressure valve, and remove cylinder from bucket of water.

11. Perform functional test (ref. subpar. "c").



12. Remove gauge charging lines from system and replace protective caps over Schrader valve fittings and tighten securely.

## 11-19 SERVICING AIR DISTRIBUTION COMPONENTS

### a. Adjustment of Temperature Control Lever and Temperature Door

NOTE: It is suggested that control wires regulating the position of the temperature control lever and the temperature door be adjusted when: air conditioner heater control assembly has been removed, or when temperature door does not properly regulate the mixing of, or blocking off of heated air.

The following adjustment procedure is based on the assumption that the control wire involved is completely disconnected. Minor after installation adjustments of the temperature lever may be accomplished, without disconnecting the control wire, by rotation of the control wire adjuster nut.

Adjustment of the vacuum diaphragms of the suction throttling valve, and outside air inlet door, although actuated by the temperature lever, is not treated in the following adjustment procedure. Refer to subparagraph 11-18, "r" for adjustment of suction throttling valve vacuum diaphragm. No adjustment is possible for the vacuum diaphragm of the water valve. The linkage between the outside air inlet door and the vacuum diaphragm on the plenum blower and air door assembly may be adjusted. To adjust, the plenum blower and air door assembly must be removed (ref. subpar.11-19 "c"). Method of adjustment will be obvious on inspection.

1. Connect temperature control wire to respective pin on heater and defroster control assembly (see Figure 11-19) and secure in position.

2. Loose assemble temperature control wire to pin located on cam of temperature door.

3. Place temperature control lever in OFF position, hold temperature door closed, and secure control wire in position at temperature cam.

4. Rotate adjuster nut until 1 1/8 to 3/16 inch springback exits when temperature control lever in OFF position.

### b. Adjustment of Air Control Lever, Defroster Door, Diverter and Deflector Doors

NOTE: It is suggested that the control wires regulating the action of the air control lever and the related doors be adjusted when: recommended springback of 1/8 to 3/16 inch not present, air conditioner heater control assembly has been removed, or when diverter, deflector, or defroster doors do not properly regulate flow of air.

The following adjustment procedure is based on the assumption that all control wires involved are completely disconnected. Minor after installation adjustment of the air lever, diverter and deflector doors may be accomplished, without disconnecting the control wires, by rotation of the control wire adjuster nut.

1. Connect defroster control wire to respective pin on heater and defroster control assembly (see Figure 11-19) and secure in position.

2. Loose assemble defroster control wire to pin located on lever of defroster valve.

3. Move air control lever to OFF position, hold defroster door closed and secure control wire in position at defroster lever.

4. Connect diverter control wire to respective pin on heater and defroster control assembly and secure in position.

5. Secure opposite end of control wire to diverter lever on heater assembly.

6. Insure that air control lever is in OFF position and rotate the control wire adjuster nut until: (1) approximately 1/8 to 3/16 inch springback is obtained when the air control lever is in OFF position, (2) approximately 1/16 inch clearance exists between surface of heater and defroster control assembly pin and edge of slot in control assembly (see Figure 11-19).

NOTE: The air control lever will lock in the mid (HTR) position if less than 1/8 inch springback occurs. The diverter door will not fully open if more than 3/16 inch springback exists.

### c. Adjustment of Vacuum Switch

To adjust vacuum switch on air conditioner heater and defroster control assembly proceed as follows:

1. Position the FAN switch lever to OFF.

2. Loosen the vacuum switch attaching screws and move the switch forward until the plunger is fully depressed.

3. Secure vacuum switch in position.

### d. Removal and Installation of Plenum Blower and Air Door Assembly

#### REMOVAL

1. Remove right front fender and skirt as follows:

(a) Unscrew four screws securing right headlamp door assembly (see Figure 11-109) to headlamp assembly.

(b) Remove four screws securing front fender to radiator baffle.

(c) Remove battery, unscrew two screws securing battery support to radiator baffle, and two screws securing battery support to fender skirt (wheelhouse), and lift out battery support.

(d) Discharge refrigerant circuit (ref. subpar. 11-18 "e").

(e) Disconnect lines to muffler and receiver-dehydrator, tape closed open lines, and also both openings in muffler and receiver-dehydrator.

(f) Unfasten all electrical wires attached to fender skirt.

(g) Remove one bolt and five screws securing front of fender skirt to radiator baffle.

(h) Remove two bolts securing front of fender to upper tie bar.

(i) Remove two bolts securing upper portion of fender to cowl.

(j) Remove one bolt securing rear edge of fender to inner portion of door jamb.

(k) Remove one bolt securing lower rear edge of fender to rocker panel.

(l) Rest a 2 x 4 inch board across cowl and radiator, and position board to support hood. Remove two bolts holding hood hinge to fender.

(m) Remove one bolt which secures fender skirt bracket to cowl.

(n) Disconnect antenna lead (if so equipped) from radio.

(o) Raise up and lift off fender and skirt and withdraw antenna lead.

2. Remove 5 stamped nuts and four screws securing plenum

blower and air door assembly to cowl (see Figure 11-110).

3. Loosen screws on duct located between evaporator and plenum blower and air door assemblies.

4. Disconnect vacuum hose from vacuum diaphragm of outside air inlet door.

5. Disconnect blower motor wire, resistor assembly lead, compressor lead, and suction throttling valve and water valve vacuum tubes, and withdraws leads and tubes from grommet in assembly.

6. Withdraw plenum blower and air door assembly from cowl and lift out.

#### INSTALLATION

7. Install assembly reverse of removal.

NOTE: During installation, mating edges between the assembly and cowl must effect a good seal. Use body sealer as required along edges of plenum chamber and also recirculate to outside air dividing rib of plenum chamber.

#### e. Removal and Installation of Air Conditioner Heater Assembly

##### REMOVAL

1. Remove right front fender and skirt as follows:

(a) Unscrew four screws securing right headlamp door assembly (see Figure 11-109) to headlamp assembly.

(b) Remove four screws securing front fender to radiator baffle.

(c) Remove battery, unscrew two screws securing battery support to radiator baffle, and two screws securing battery support to fender skirt (wheelhouse), and lift out battery support.

(d) Discharge refrigerant circuit (ref. subpar. 11-18 "e").

(e) Disconnect lines to muffler and receiver-dehydrator, tape closed open lines, and also both openings in muffler and receiver-dehydrator.

(f) Unfasten all electrical wires attached to fender skirt.

(g) Remove one bolt and five screws securing front of fender skirt to radiator baffle.

(h) Remove two bolts securing front of fender to upper tie bar.

(i) Remove two bolts securing upper rear portion of fender to cowl.

(j) Remove one bolt securing rear edge of fender to inner portion of door jamb.

(k) Remove one bolt securing lower rear edge of fender to rocker panel.

(l) Rest a 2 x 4 inch board across cowl and radiator, and position board to support hood. Remove two bolts holding hood hinge to fender.

(m) Remove one bolt which secures fender skirt bracket to cowl.

(n) Disconnect antenna lead (if so equipped) from radio.

(o) Raise up and lift off fender, and withdraw antenna lead.

2. Remove five stamped nuts from lower portion of plenum blower and air door assembly.

3. Remove glove box, disconnect air conditioner outlet hoses from distributor duct (see Figure 11-111). Remove two screws securing duct to heater assembly and take out duct.

4. Disconnect temperature, diverter, and defroster control wires (see Figure 11-19).

5. Remove rear retainer and seal assembly (see Figure 11-111) and pull out air conditioner heater assembly.

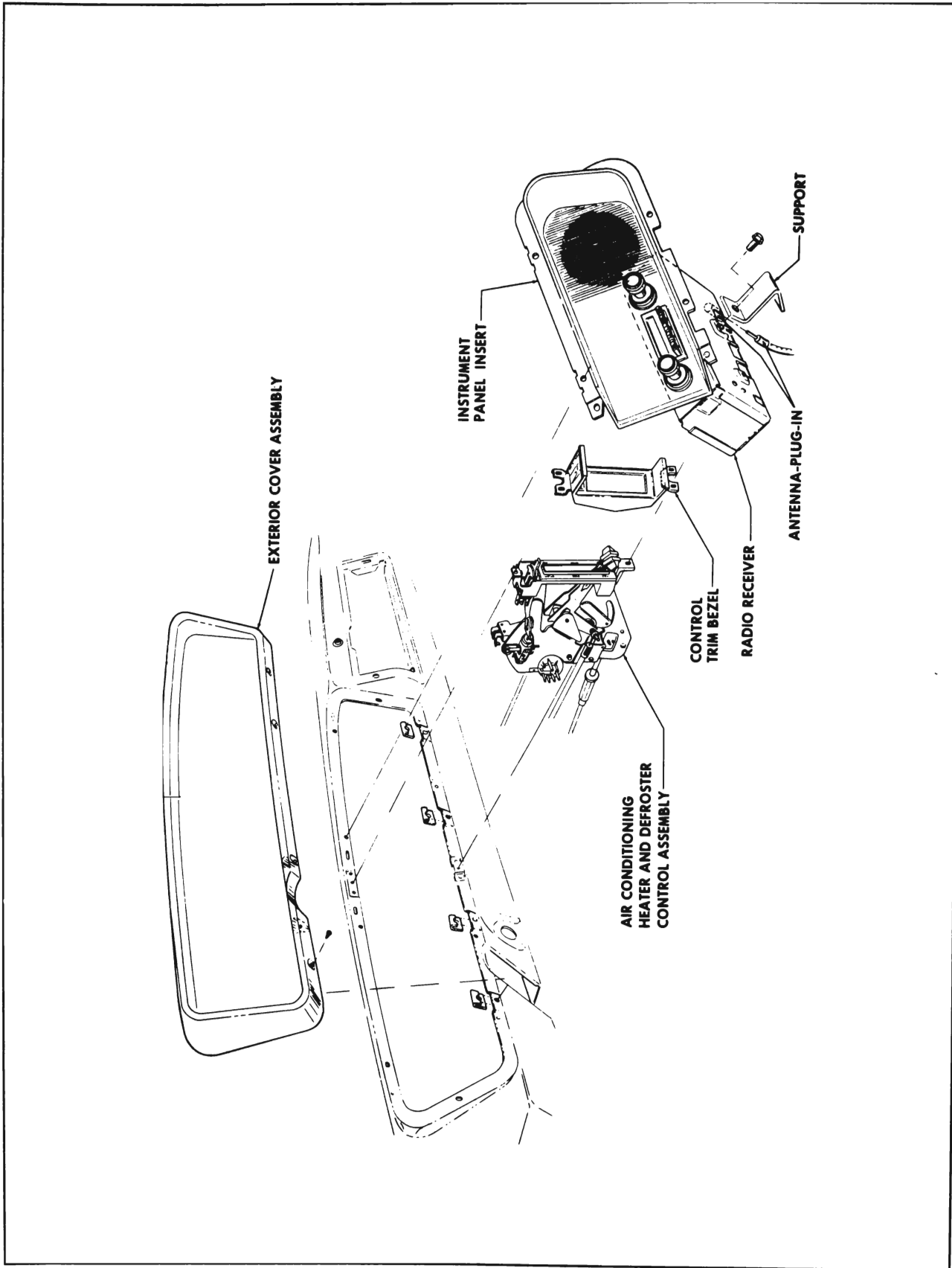

Figure 11-114—Air Conditioner Heater and Defroster Control Assembly Installation

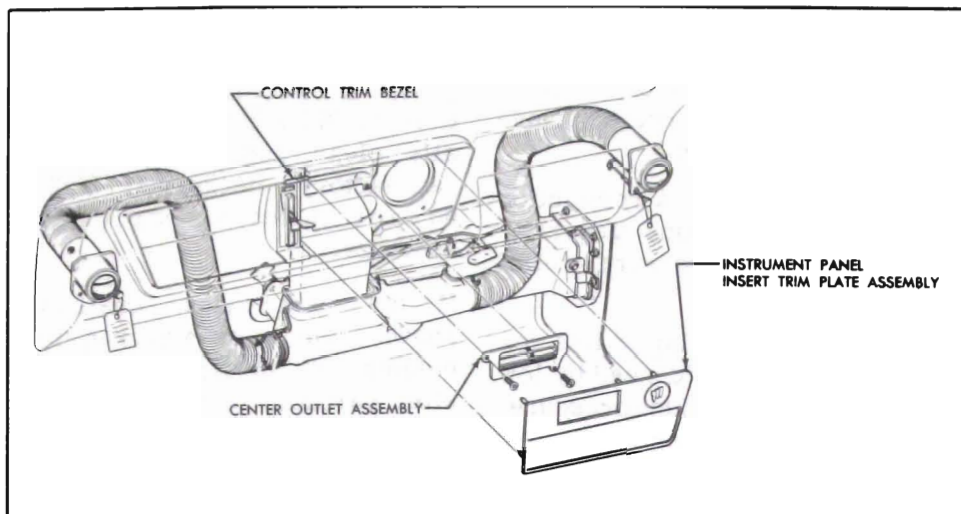

Figure 11-115—Dash Units Installation

## INSTALLATION

6. Install heater assembly reverse of removal and check for proper operation of control levers.

### f. Removal and Installation of Air Conditioner Control Assembly

#### REMOVAL

1. Remove five screws and take out exterior cover assembly (see Figure 11-114).
2. Remove four screws from control trim bezel and take out bezel.
3. Remove ash tray assembly and take out screw holding support to radio receiver.
4. Remove four screws securing instrument panel insert to instrument panel and partially withdraw insert. Disconnect radio lead and antenna lead connectors and complete removal of assembly.
5. Remove three screws securing control assembly to instrument panel and partially withdraw control assembly.
6. Disconnect all attached control wires, clutch compressor switch and heater blower switch connectors, vacuum hoses, and lamp holder from heater and defroster

control assembly. Complete removal of assembly.

#### INSTALLATION

7. Install control assembly reverse of removal and check controls for proper operation.

## 11-20 TROUBLE DIAGNOSIS

The following is a brief description of the type of symptom each refrigerant component will evidence if a malfunction occurs:

### a. Compressor

Compressor malfunction will appear in one of four ways: noise, seizure, leakage, or low discharge pressure.

NOTE: Resonant compressor noises are not cause for alarm; however, irregular noise or rattles are likely to indicate broken parts. To check seizure, de-energize the magnetic clutch and check to see if drive plate can be rotated. If rotation is impossible, compressor is seized. To check for a leak, refer to subparagraph 11-18 "d". Low discharge pressure may be due to a faulty internal seal of the compressor, or a restriction in the compressor.

NOTE: Low discharge pressure may also be due to an insufficient refrigerant charge or a restriction elsewhere in the system. These possibilities should be checked prior to servicing the compressor. If the compressor is inoperative; however, is not seized, check to see if current is being supplied to the magnetic clutch coil terminals.

### b. Condenser

A condenser may malfunction in two ways: it may leak, or it may be restricted. A condenser leak will be evidenced by low system pressure. A condenser restriction will result in excessive compressor discharge pressure. If a partial restriction is present, sometimes ice or frost will form immediately after the restriction as the refrigerant expands after passing through the restriction. If air flow through the condenser or radiator is blocked, high discharge pressures will result. During normal condenser operation, the outlet pipe will be colder than the inlet pipe.

### c. Receiver-Dehydrator

A receiver-dehydrator may fail due to a restriction inside of body of the unit. A restriction at the inlet to the receiver-dehydrator will cause high head pressures. Outlet tube restrictions will be indicated by low head pressures and little or no cooling. An excessively cold receiver-dehydrator outlet may be indicative of a restriction.

### d. Expansion Valve

Expansion valve failures usually will be indicated by low suction and discharge pressures, and insufficient evaporator cooling. The failure is generally due to malfunction of the power element and subsequent closing of the valve. A less common cause of the above symptom is a clogged inlet screen.

### e. Evaporator

When the evaporator malfunctions, the trouble will show up as inadequate supply of cool air. A partially plugged core due to dirt, a cracked case, or a leaking seal will generally be the cause.

### f. Suction Throttling Valve

If the suction throttling valve is defective, it may cause evaporator pressure (hence air temperature) to be either too high or too low depending on the type of failure. Prior to servicing valve, perform adjustment procedures (ref. subpar. 11-16 "r"). If vaporator pressure remains high after adjusting, the expansion valve may be malfunctioning.

### g. Refrigerant Line Restrictions

Restrictions in the refrigerant lines will be indicated as follows:

1. Suction - A restricted suction line (see Figure 11-27) will cause low suction pressure at the compressor, low discharge pressure and little or no cooling.

2. Discharge Line - A restriction in the discharge line generally will cause the pressure relief valve to open.

3. Liquid Line - A liquid line restriction will be evidenced by low discharge and suction pressure, and insufficient cooling.

### h. Use of Receiver Sight Glass for Diagnosis

At temperatures higher than 70°F., the sight glass may indicate whether the refrigerant charge is sufficient. A shortage of liquid refrigerant is indicated after about five minutes of compressor operation by the appearance of slow-moving bubbles (vapor) or a broken column of refrigerant under the glass. Con-

tinuous bubbles may appear in a properly charged system on a cool day. This is a normal situation. If the sight glass is generally clear and performance is satisfactory, occasional bubbles do not indicate refrigerant shortage.

If the sight glass consistently shows foaming or a broken liquid column, it should be observed after partially blocking the air to the condenser. If under this condition the sight glass clears and the performance is otherwise satisfactory, the charge shall be considered adequate.

In all instances where the indications of refrigerant shortage continues, additional refrigerant should be added in 1/4 lb. increments until the sight glass is clear. An additional charge of 1/2 lb. should be added as a reserve. In no case should the system be overcharged.

**TROUBLE-SHOOTING TABLE**

TROUBLE AND SYMPTOM	CAUSE AND CORRECTION
<p>1. Insufficient Cooling</p> <p>a. Low air flow</p> <p>b. Air temperature not cool</p> <p>c. Improper operation of system</p>	<p>a. Check that blower is operative, proper valve operation, obstructions, or iced evaporator core. Check adjustment of suction throttling valve (ref. subpar. 11-18 "r").</p> <p>b. Check suction throttling valve and adjust if necessary (ref. subpar. 11-18 "r"). Check that manual gate valve is closed.</p> <p>c. Vents and windows open, and/or improper operation of controls. Correctly advise owner.</p>
<p><u>NOTE: If the above corrections do not remedy the complaint, perform the functional test (ref. subpar. 11-18 "c"). If complaint is not corrected, check items 2, 3, 4 and 5 of this table.</u></p>	
<p>2. Compressor Discharge Pressure Too High</p>	<p>2. Engine overheated (refer to Section 2 of this manual for correction).</p> <p>Overcharge of refrigerant in system. Release pressure slowly.</p>
<p><u>NOTE: If pressure drops rapidly, air or moisture in the refrigerant is indicated. A slow decrease in pressure indicates only an excessive refrigerant charge. Release pressure until pressure gauges are within specifications (ref. Figure 11-47) or pressure drop levels. Release just enough additional refrigerant to cause bubbles or foam to appear in the receiver-dehydrator sight glass. Recharge to eliminate bubbles or foam, and then add additional 1/2 lb. of refrigerant. If system pressures remain high and are not corrected, there is possibility a restriction in the high pressure side of the system.</u></p>	
<p>Restriction in condenser or receiver-dehydrator. Repair or replace as applicable. Condenser air flow blocked. Clean fins of condenser and radiator. Also refer to item 4 of this table.</p>	
<p>3. Compressor Discharge Pressure Too Low</p> <p>a. Bubbles or foam under indicator sight glass</p>	<p>a. Insufficient refrigerant charge (ref. subpar. 11-18, "c"). Charge system until sight glass clears and then add an additional 1/2 lb of refrigerant.</p>

**TROUBLE-SHOOTING TABLE (Cont.)**

TROUBLE	CAUSE & CORRECTION
3. Compressor Discharge Pressure Too Low (Cont'd.) b. Inadequate cooling	b. Defective compressor such as broken reed valves, leaking internal seal. Repair compressor as required (ref. subpar. 11-18, "k").
4. Evaporator Pressure Too High	4. Capillary bulb loose. Secure bulb to evaporator outlet pipe. Check expansion valve and/or suction throttling valve. Replace or adjust, whichever applicable.
5. Evaporator Pressure Too Low and Core Freezing	5. Check expansion valve and clean or replace as necessary. Check for restriction in liquid lines and correct as necessary. Check and adjust suction throttling valve if necessary (ref. subpar. 11-18, "r").

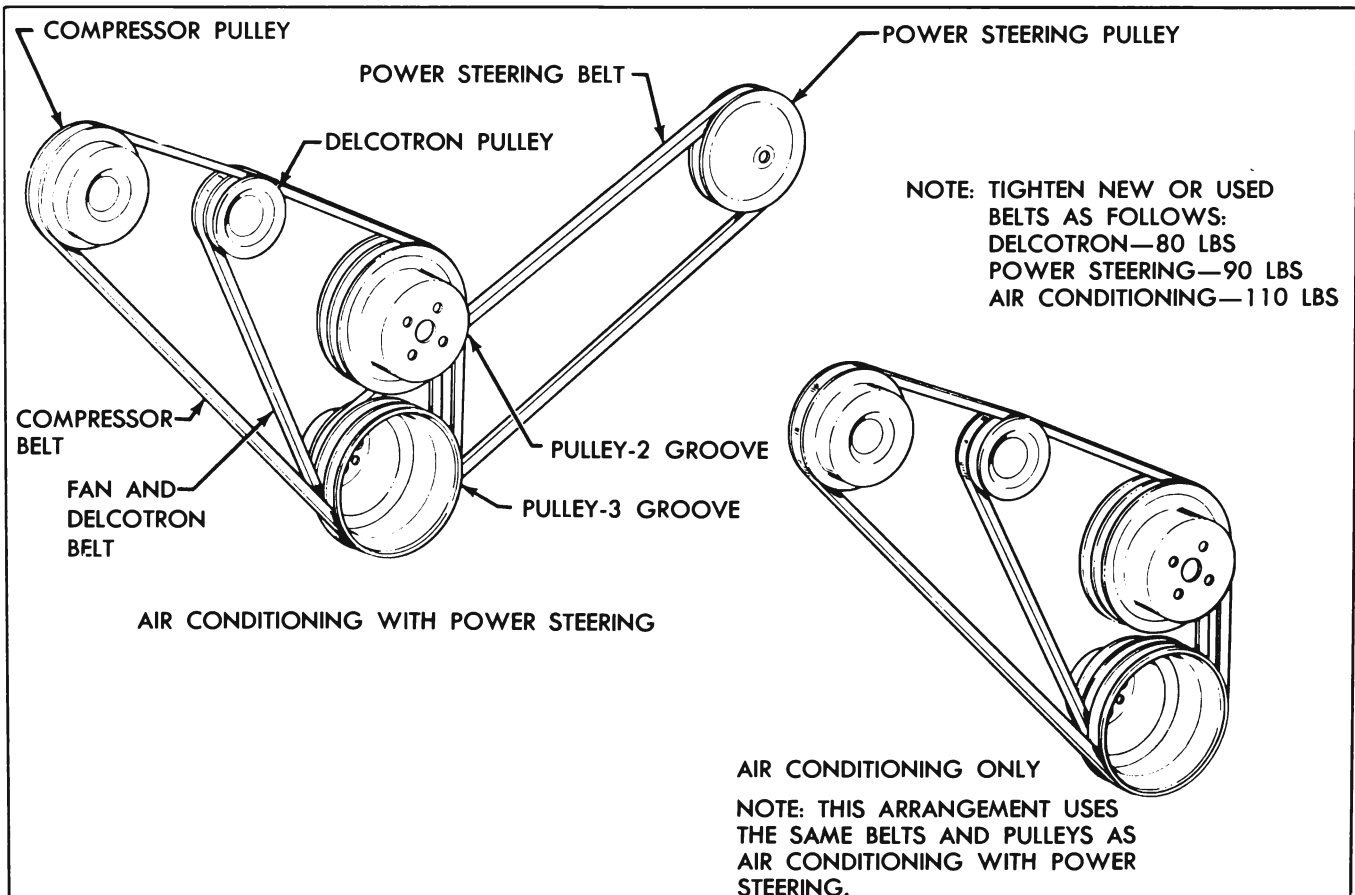

Figure 11-116—Belt and Pulley Installation

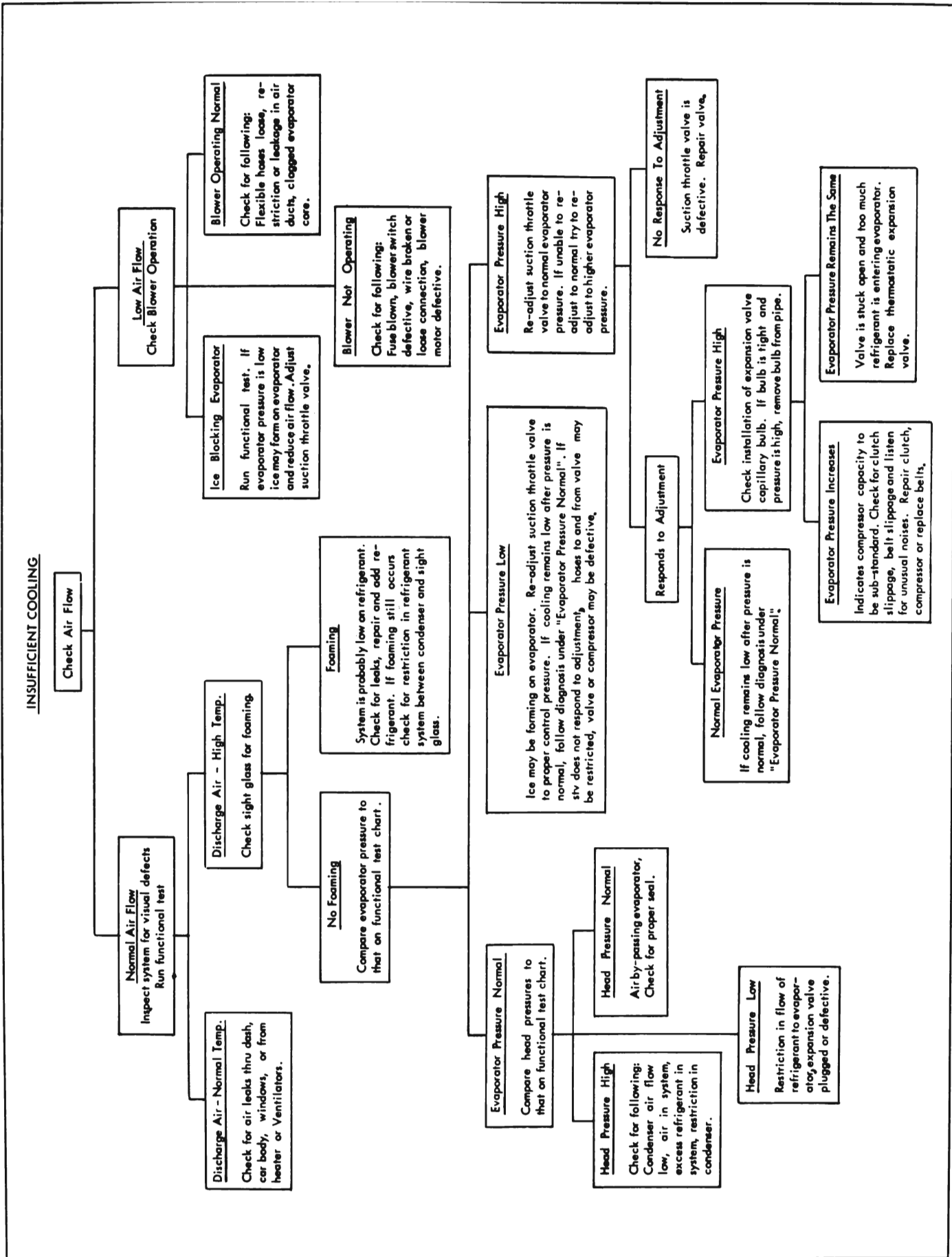

Figure 11-117—Air Conditioner Trouble Diagnosis Chart



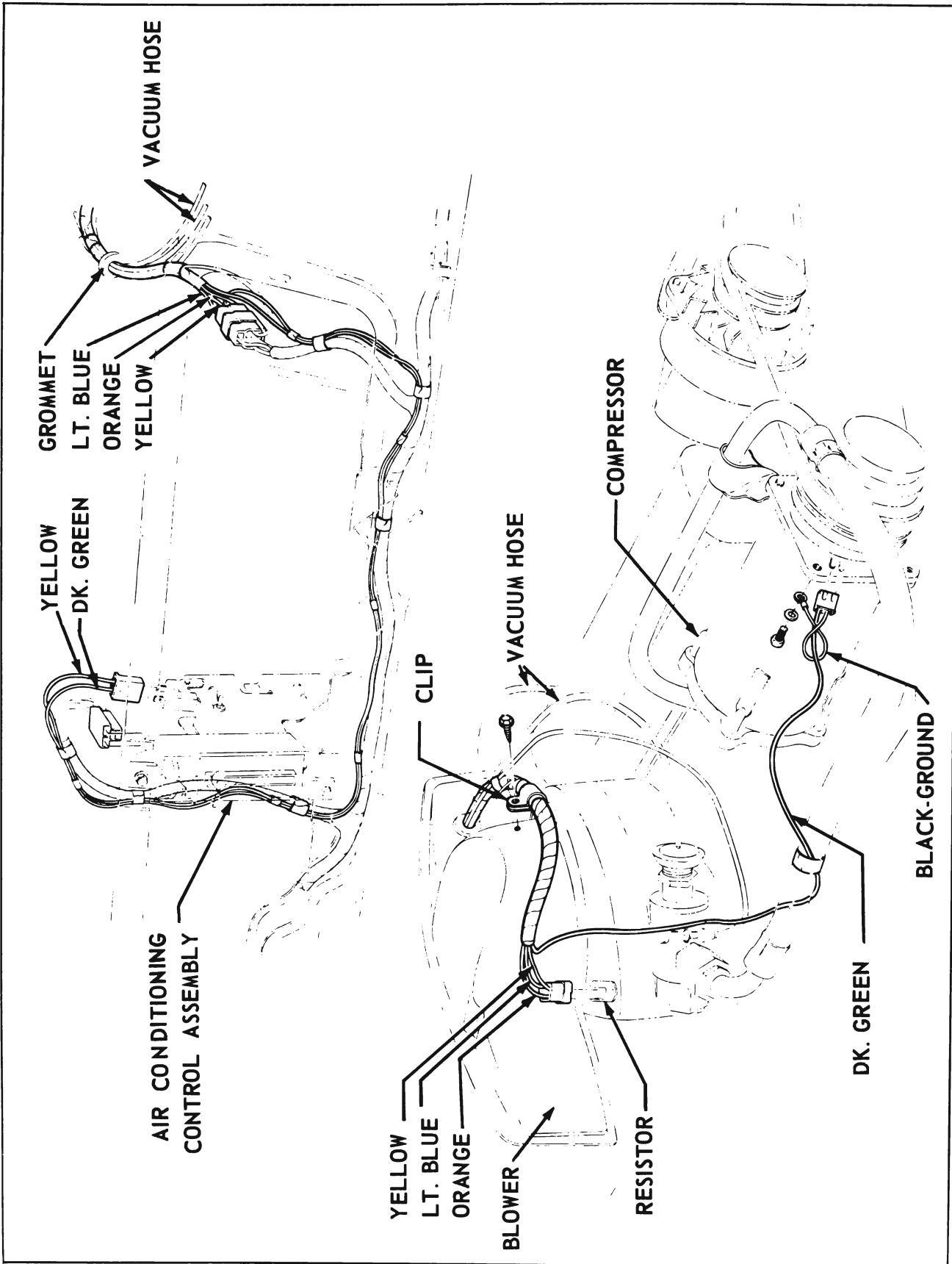

Figure 11-118—Air Conditioner Wiring Installation

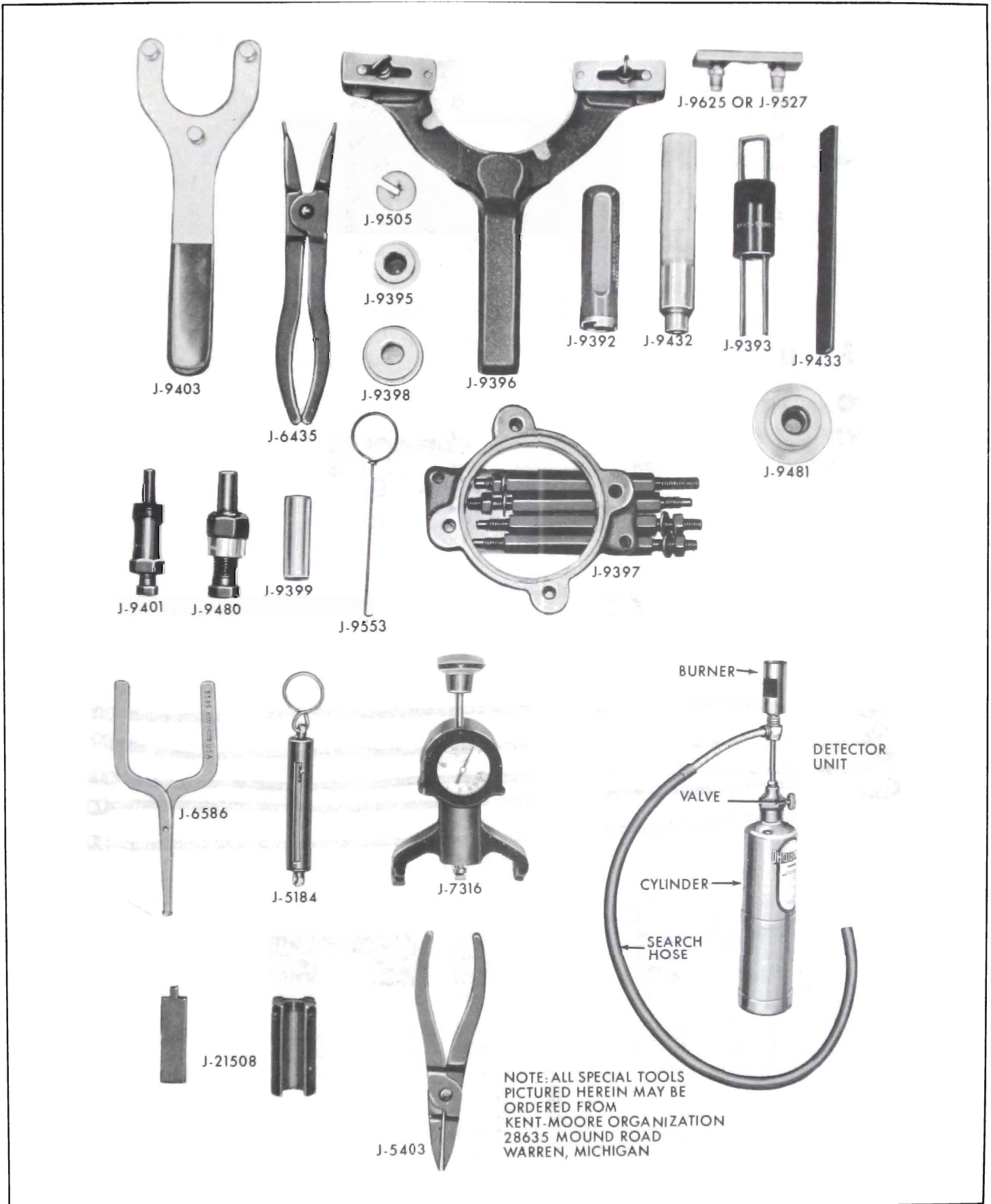

Figure 11-119—Special Tools (Page 1 of 2)

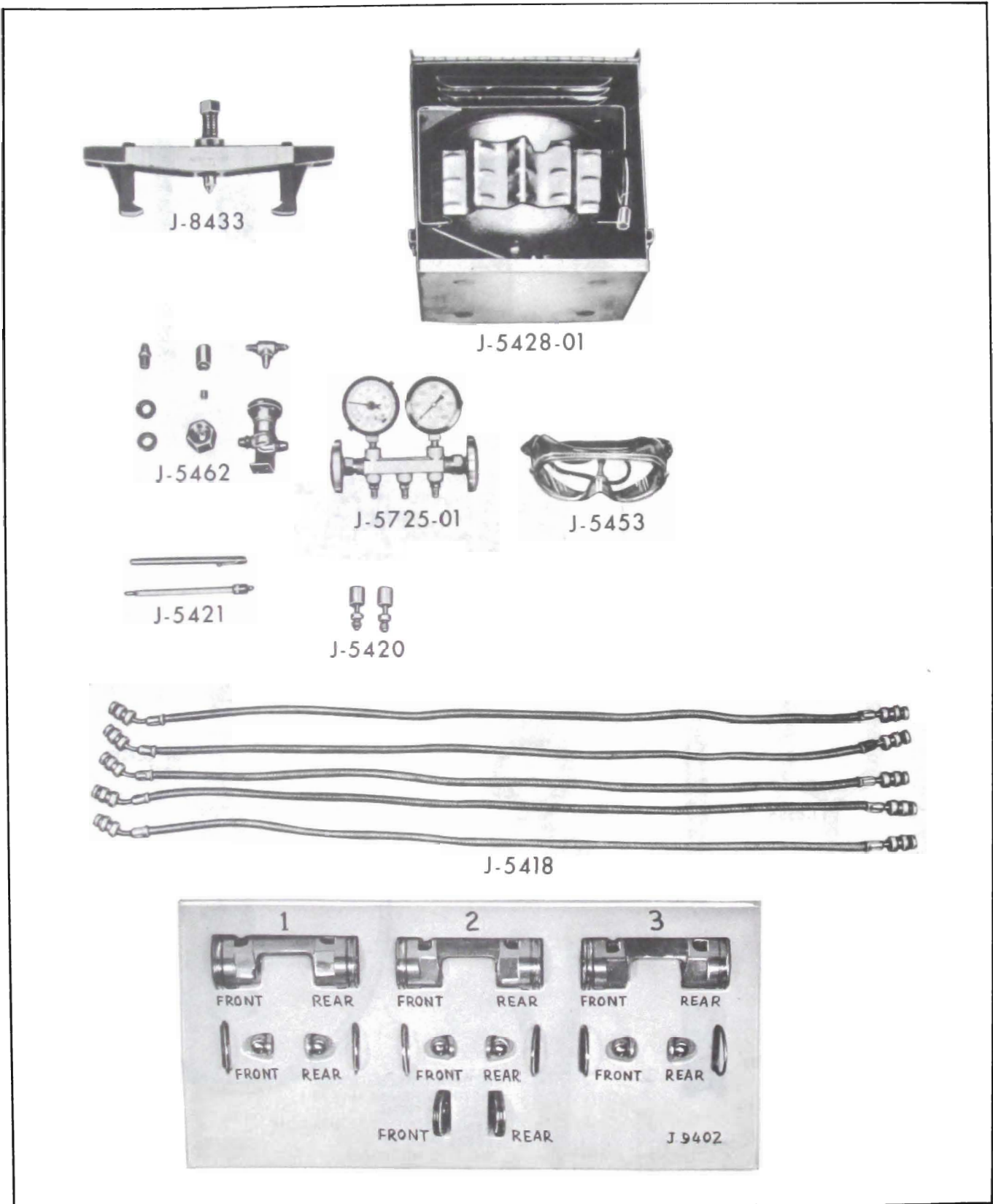

Figure 11-119—Special Tools (Page 2 of 2)