

SECTION 10-H INSTRUMENTS AND CLOCK

CONTENTS OF SECTION 10-H

Paragraph	Subject	Page	Paragraph	Subject	Page
10-48	Instrument Cluster Assembly, Generator Indicator, Oil Pressure Indicator, Temperature Indicator	10-57	10-49	Electric Clock	10-65
			10-50	Gasoline Gauge - Dash and Tank Units	10-65
			10-51	Speedometer	10-66

10-48 INSTRUMENT CLUSTER ASSEMBLY, GENERATOR INDICATOR, OIL PRESSURE INDICATOR, TEMPERATURE INDICATOR

a. Description of Instrument Cluster Assembly

The instrument cluster assembly shown in Figure 10-61 contains the speedometer, fuel gauge, indicator lights and clock. For the instrument cluster location on the instrument panel, see Figure 10-62.

The generator, temperature and oil pressure indicators use red lights to warn the driver of conditions other than normal when the engine is running.

A printed circuit which is part of the speedometer housing is

used to complete the circuit for the fuel gauge and the lights in the cluster assembly. See Figure 10-63.

A disconnect plug which is part of the chassis wiring harness attaches to the printed circuit connector pins. A keyway is located in the printed circuit to

insure correct assembly of the disconnect plug on the connector pins. If the printed circuit should become defective, it should be replaced as it is not practical to repair it.

To remove the printed circuit and housing assembly it is necessary to remove the instrument cluster.

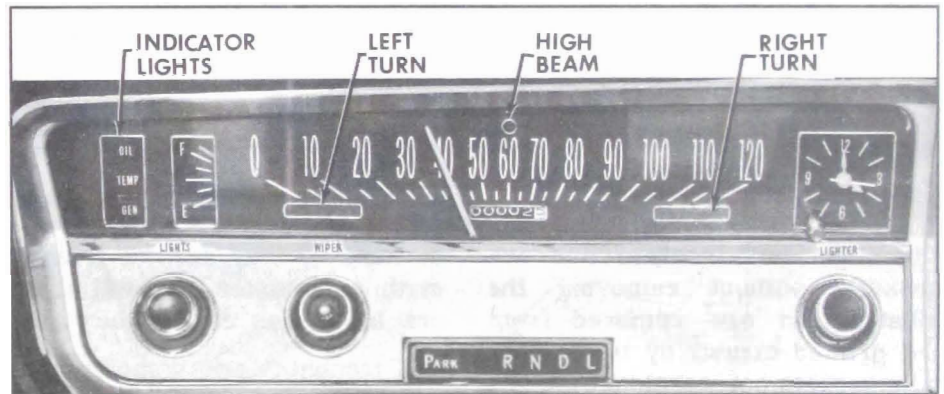

Figure 10-61—Instrument Cluster

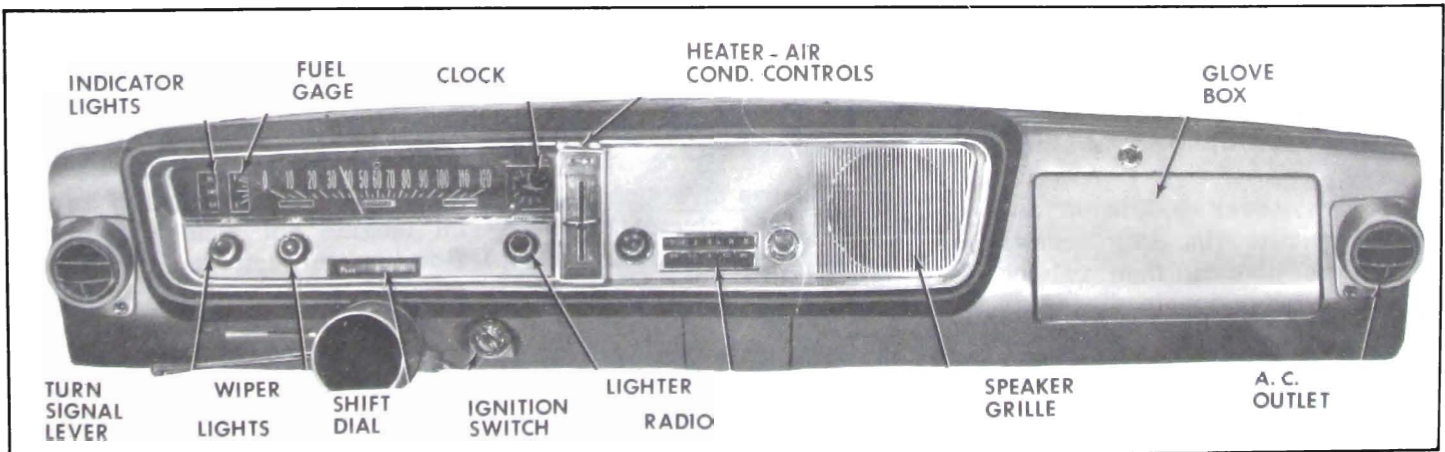

Figure 10-62—Instrument Panel

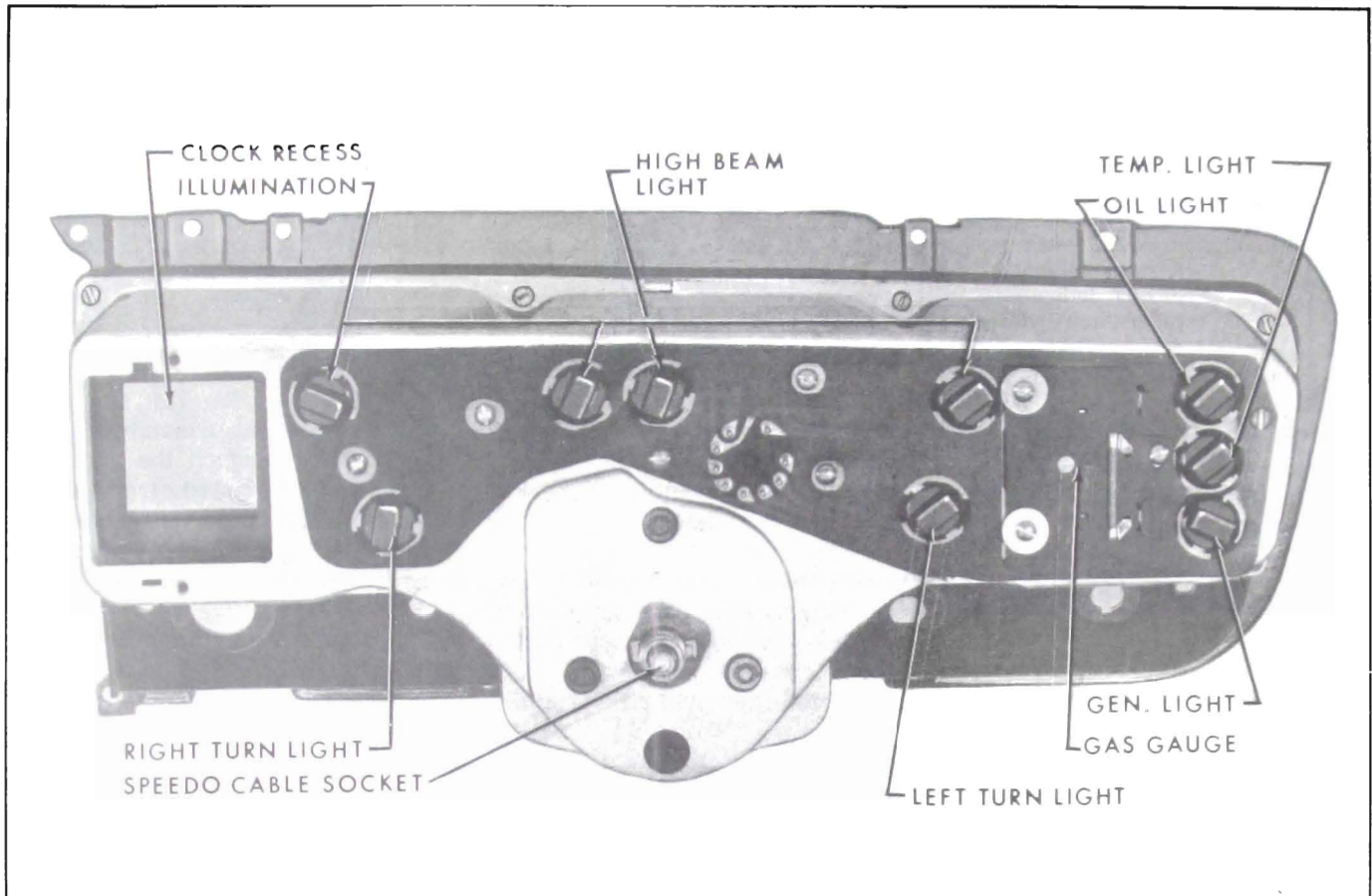

Figure 10-63—Instrument Cluster - Back Side

The light bulb sockets are accessible without removing the cluster and are removed from the printed circuit by turning the bulb sockets counterclockwise.

CAUTION: Disconnect battery ground cable from battery terminal before removing any instrument panel unit or wiring.

b. Removal and Installation of Instrument Cluster Assembly

1. Remove cover extension assembly by removing four screws across the bottom, then raising the entire extension to disengage it from four clips across the top. See Figure 10-65.

2. Remove heater control trim bezel by removing four screws from corners. See Figure 10-64.

3. Remove four screws from instrument cluster and pull cluster out as far as connections allow.

4. Disconnect speedometer cable, printed circuit plug, shift indicator lamp, clock wire, light switch connector, wiper switch wires, lighter wire and accessory switch wires (if any).

5. Remove cluster.

6. Reinstall instrument cluster by reversing above steps.

NOTE: Observe direction of keyway in printed circuit to make blind installation of cluster plug easier.

c. Generator Charge Indicator

The red "GEN" warning light should light when the ignition is turned "ON" and before the engine is started; if not lighted,

either the bulb is burned out or the indicator light wiring has an open circuit. After the engine is started, the "GEN" light should be out at all times; if the light comes on, the generator belt may be loose or missing, the generator or regulator may be defective, or the charging circuit may be defective. See paragraph 10-18 for trouble shooting procedures.

To trace the generator indicator light circuit, see Figure 10-68. With the ignition switch turned on (engine not running), current flow is through the ignition switch, out the "IGN" terminal, through the generator light in the instrument cluster, to the "4" terminal of the regulator, through the lower contacts of the voltage regulator (held closed by the spring), out the "F" terminal, in the "F" terminal of the generator,

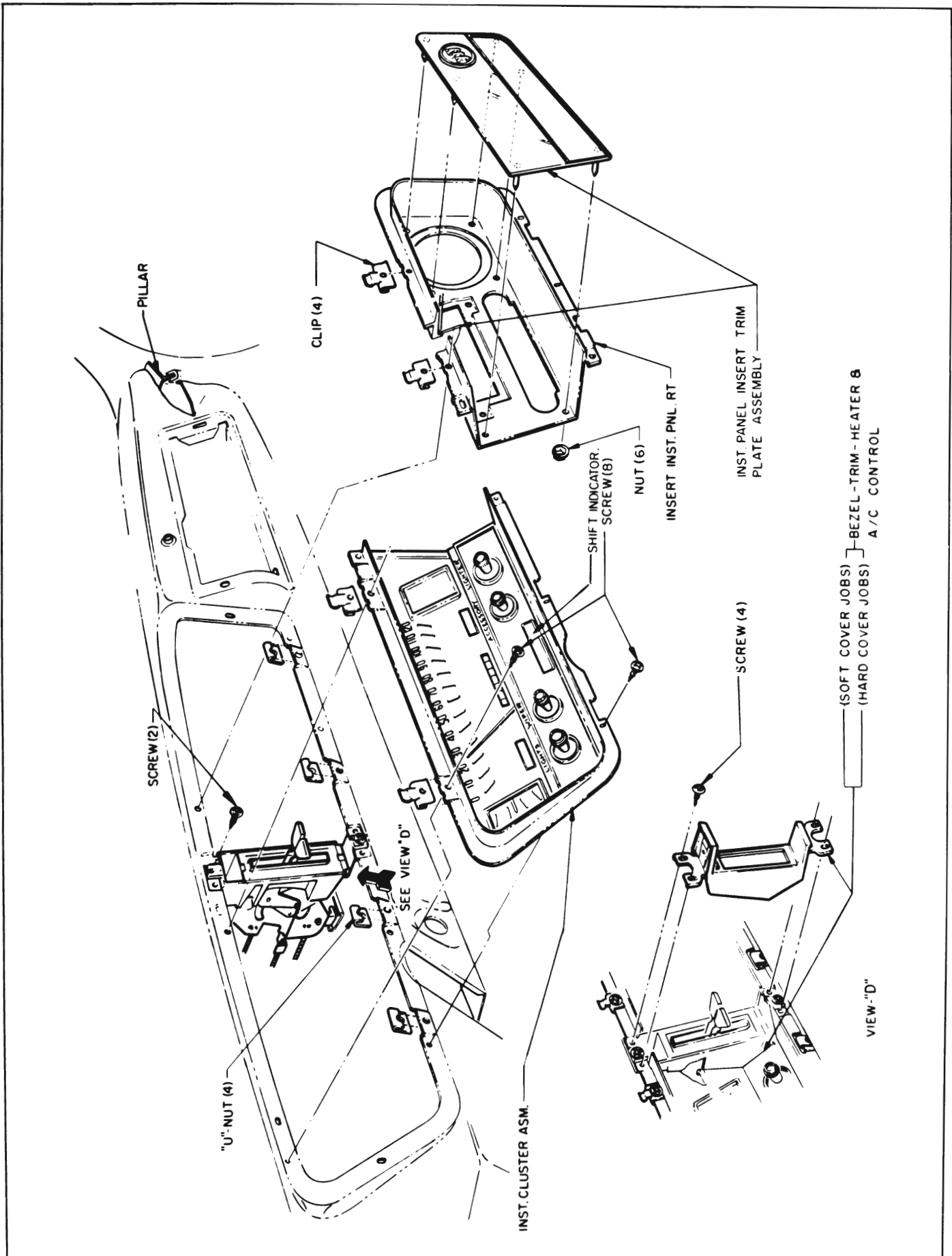

Figure 10-64—Instrument Panel and Right Insert Installation

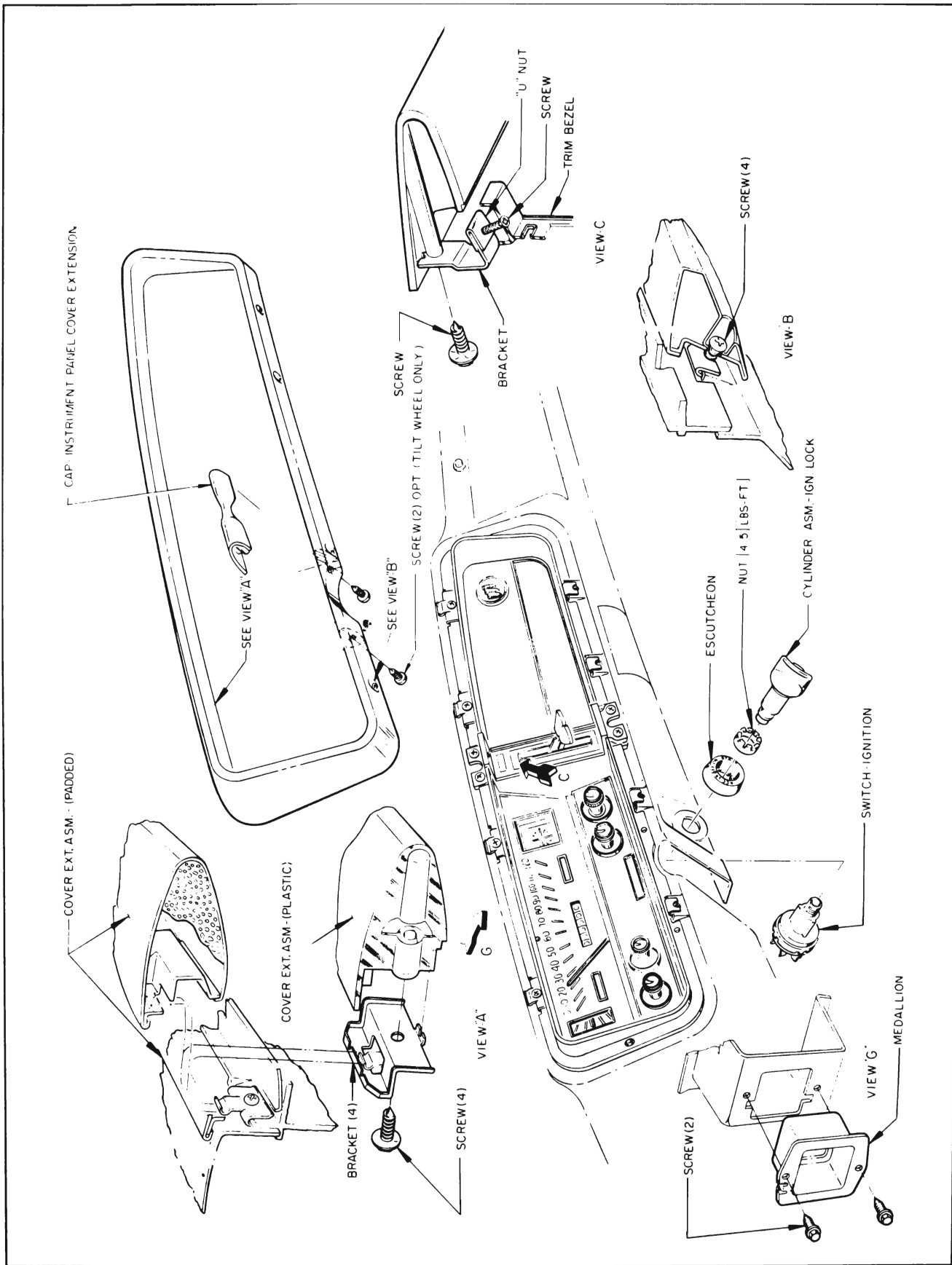

Figure 10-65—Instrument Panel Cover Extension and Ignition Switch Installation

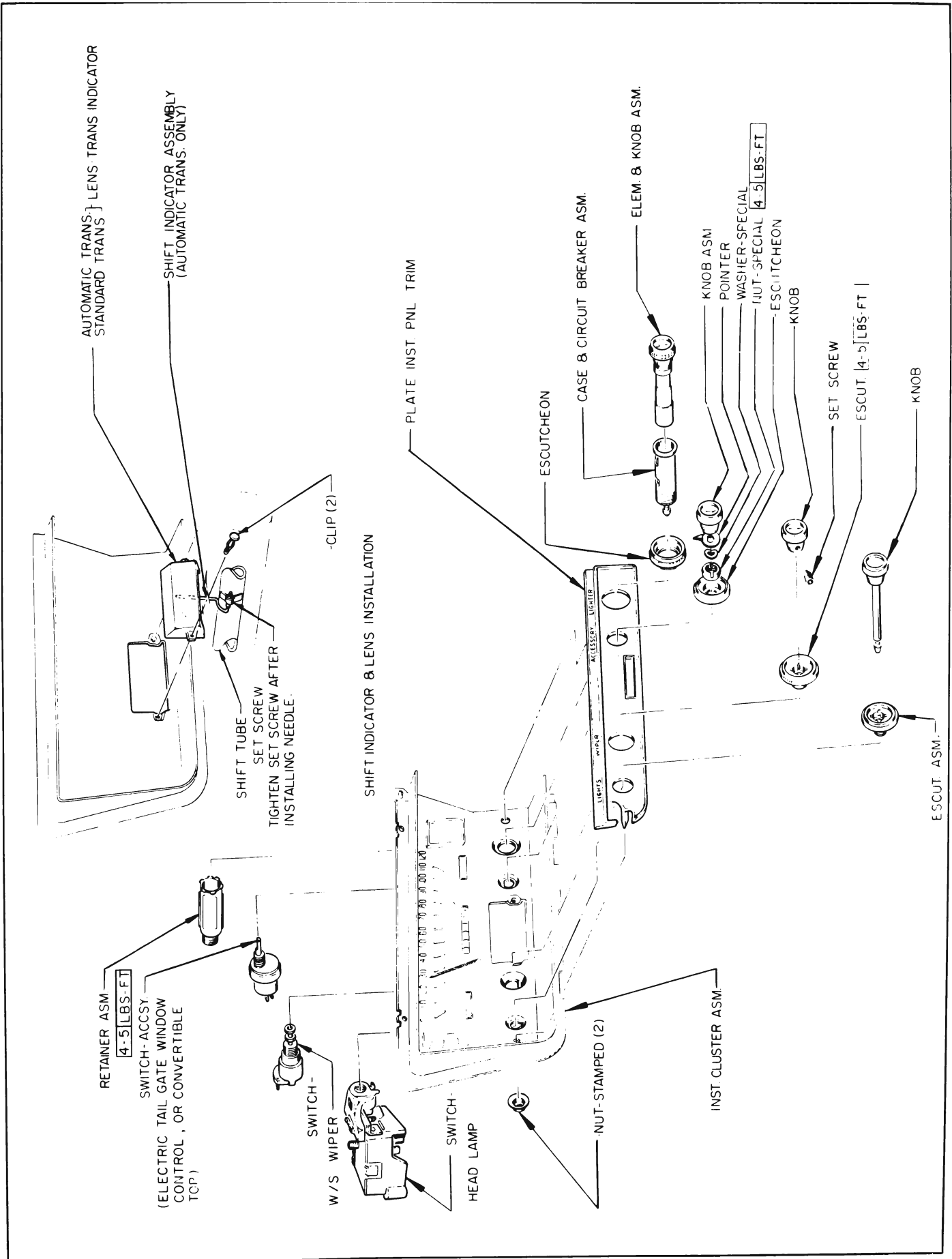

Figure 10-66—Instrument Panel Switch Installation

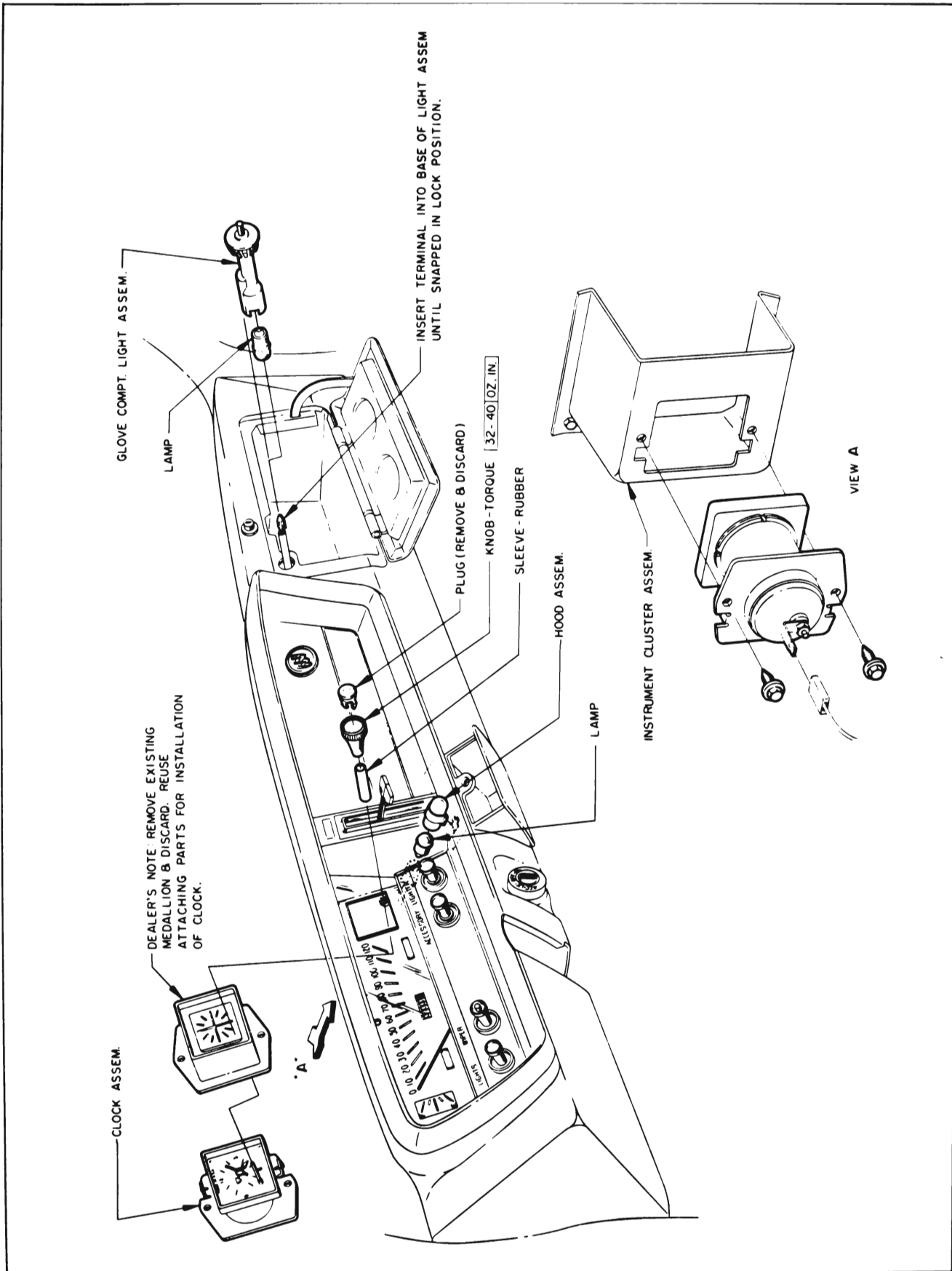

Figure 10-67—Clock, Ash Tray Light and Glove Box Light Installation

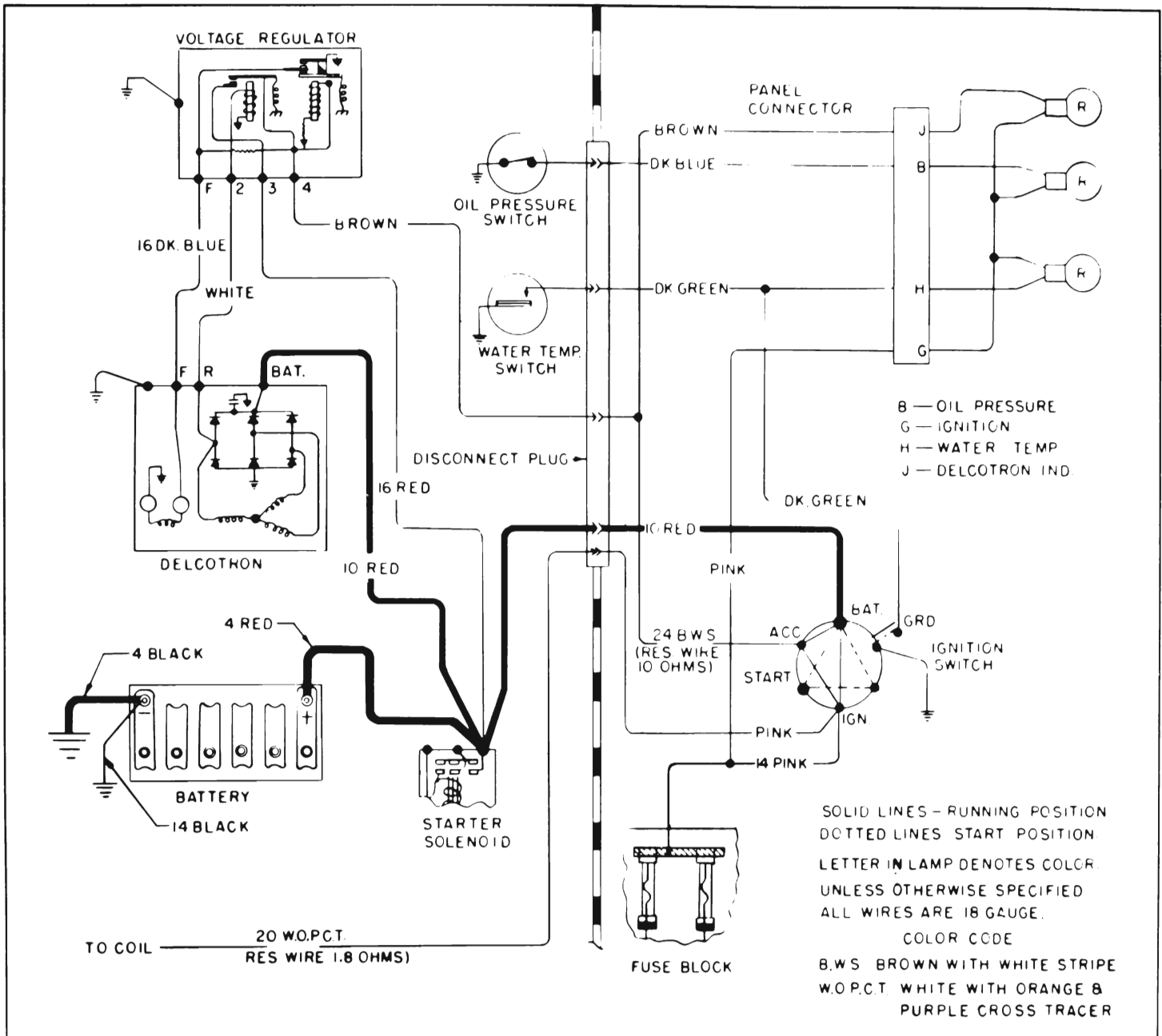

Figure 10-68—Indicator Light Circuits

through the brush and slip ring, through the field, through another brush and slip ring to ground.

Before the engine is started, the generator light should glow at about 1/2 brightness. This is because the voltage in the circuit before the light is about 12 volts, but the voltage at the "4" terminal after the light is about 5 volts. This makes the effective voltage across the generator light approximately 7 volts for about 1/2 brightness.

After the engine is started, the voltage put out by the generator immediately closes the field relay. This causes battery voltage from the "3" terminal to be present at the "4" terminal. See Figure 10-68. Since battery voltage is present on both sides of the generator light, the light goes out. If the generator light comes on with the engine running, the charging circuit should be tested at the first opportunity to determine the cause of the trouble. See paragraph 10-21.

d. Oil Pressure Indicator

The engine oil pressure indicator light is controlled by a pressure operated switch located in the oil pump cover. This light should come on when the ignition is turned "on" and the engine is not running. If not lit, either the bulb is burned out, the wiring has an open circuit or the oil switch is defective.

If the engine oil pressure drops below a safe level during operation, the circuit is completed

through the pressure switch to ground, and the "Oil" indicator light in the cluster will be turned on. See Figure 10-68.

If the "Oil" indicator stays on or comes on when the engine is running at speeds above idle, stop engine immediately and find out reason. The following may be the cause, rather than low oil pressure:

1. Wiring circuit between oil pressure switch and light grounded. Remove connector from pressure switch, if light stays on trouble is in wiring.

2. Switch defective. Replace switch.

e. Temperature Indicator

A temperature switch located in right front of the intake manifold controls the operation of the "Temp" indicator light located in instrument cluster.

If the engine cooling system is not functioning properly and the water temperature should reach 248°F., the "Temp" indicator will be turned on by the temperature

switch. As a test circuit to check whether the "Temp" indicator bulb is functioning properly, a wire which is connected to the "GND" terminal of ignition switch is tapped into the temperature switch circuit. See Figure 10-68. When the ignition is in the "Start" position (engine cranking), the "GND" terminal is grounded inside switch and the "Temp" bulb will be lit. When the engine is started and the ignition switch is in the "On" position, the test circuit is opened and the bulb is then controlled by the temperature switch.

COMPLAINT	POSSIBLE CAUSE
<p>1. GENERATOR INDICATOR</p> <p>Light not lit, ignition "On" and engine not running.</p> <p>Light on, engine running.</p>	<p>Bulb burned out. Replace.</p> <p>Open in light circuit. Locate and correct.</p> <p>No generator output. Check output, paragraph 10-21.</p> <p>Loose or broken generator belt.</p>
<p>2. OIL PRESSURE INDICATOR</p> <p>Light not lit, ignition "On" and engine not running.</p> <p>Light on, engine running above idle speed.</p>	<p>Bulb burned out. Replace.</p> <p>Open in light circuit. Locate and correct.</p> <p>Oil pressure switch defective. Replace.</p> <p>Wiring between light and switch grounded. Locate and correct.</p> <p>Oil pressure switch defective. Replace.</p> <p>Low oil pressure. Locate cause and correct.</p>
<p>3. TEMPERATURE INDICATOR</p> <p>Light not lit when cranking engine.</p> <p>Light on, engine running.</p>	<p>Bulb burned out. Replace.</p> <p>Open in light circuit. Locate and correct.</p> <p>Ignition switch defective. Replace.</p> <p>Wiring between light and switch grounded. Locate and correct.</p> <p>Temperature switch defective. Replace.</p> <p>Cooling system water temperature above 248°F. Find cause and correct.</p> <p>Ignition switch defective. Replace.</p>

f. Trouble Diagnosis— Generator Indicator, Oil Pressure Indicator, Temperature Indicator

Use Figure 10-68 to trace wiring circuits for indicator lights and Figure 10-63 for location of indicator light bulb sockets. To determine if there is a ground in the indicator light circuit, remove connector from control switch. If light stays on, trouble is in circuit.

10-49 ELECTRIC CLOCK

The electric clock is mounted in the right end of the instrument cluster. The clock wiring circuit is protected by the 10 ampere "TAIL-CLOCK" fuse on the fuse block. Clock light brilliance is controlled by the rheostat in the lighting switch and is protected by the "PANEL" fuse on the fuse block.

a. Clock Time Reset and Automatic Regulation

The electric clock incorporates a sweep-second hand and an automatic regulator. A reset knob extends through the glass on bottom of the clock dial. To reset the time, pull the knob out and turn in either direction as required. See Figure 10-69.

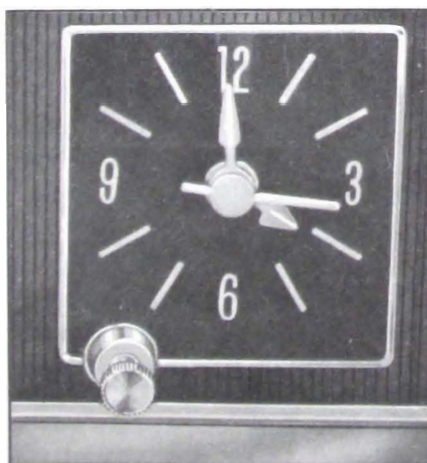

Figure 10-69—Electric Clock

There is no regulator knob because regulation is accomplished automatically by the action of resetting the time. If a clock is running fast, the action of turning the hands back to correct the time will automatically cause the clock to run slightly slower; if a clock is running slow, the action of turning the hands forward to correct the time will automatically cause the clock to run slightly faster (10 to 15 seconds per day).

A lockout feature prevents the regulator mechanism from being moved more than once during a rewind period (approximately 3 minutes), regardless of the number of times the clock reset is operated. After clock rewinds, if it is again reset, automatic regulation will take place.

b. Clock Service

The clock manufacturers have established Authorized Service Stations in many cities throughout the United States and Canada. These service stations are prepared to carry out terms of the manufacturer's warranty and also to perform any repairs made necessary through use of clock.

When a clock requires warranty service or repairs other than regulation, it should be removed by the Buick dealer and sent to the nearest authorized service station. The manufacturer's warranty is void if repairs have been attempted outside of an authorized service station.

10-50 GASOLINE GAUGE— DASH AND TANK UNITS

The gasoline gauge consists of two units: the dash unit located in the instrument cluster, and the tank unit located in the gasoline tank. One terminal of the dash unit is connected to the ignition switch so that the unit registers only when the ignition switch is turned on.

With the ignition turned off, the pointer may register any place on the dial of gauge. The other terminal of the dash unit is connected by a single wire to the tank unit, which is grounded on the tank to complete the circuit. See Figure 10-70.

The dash unit pointer is moved by changing the magnetic pull of

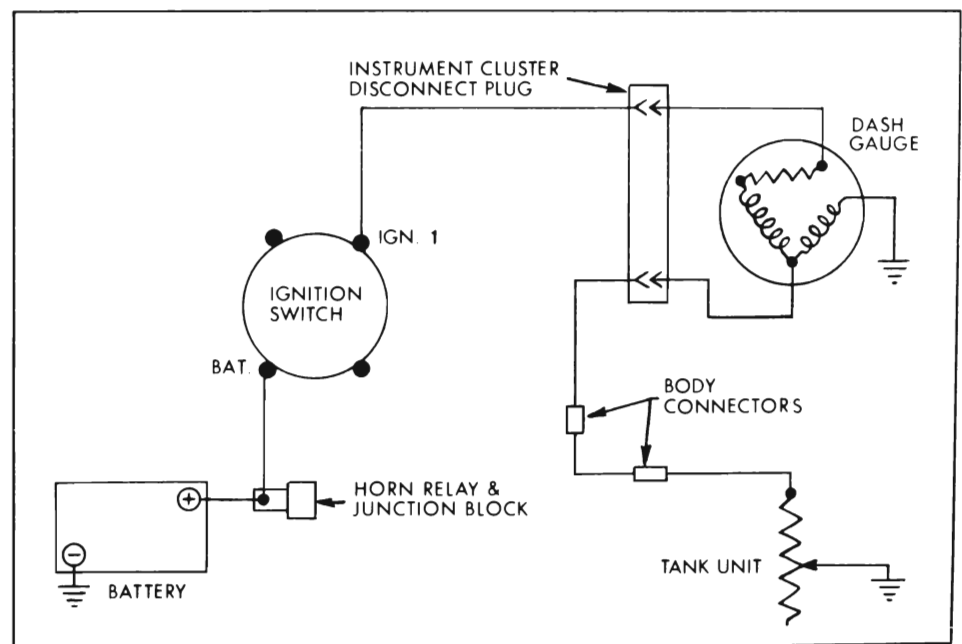

Figure 10-70—Fuel Gauge Circuit

two coils in the unit. The magnetic pull is controlled by action of the tank unit which contains a variable rheostat, the value of which varies with movement of a float and arm. The tank unit is mounted in the tank so that the float rises and falls on the surface of the gasoline near the middle of the tank. The float is adjusted to provide approximately 1 gallon reserve when the dash unit pointer is at the dot next to the "E" position.

If the gasoline gauge does not operate properly, the dash unit, wiring between dash unit and tank unit and tank unit should be separately tested to determine which is at fault. The units and wiring may be tested by using a known good tank unit with a 12 foot piece of red insulated (#16) wire attached to binding post of unit and a similar 5 foot piece of black wire attached to flange of unit. Attach a spring clip to end of black wire and a terminal to end of red wire.

a. Test of Dash Unit and Tank Unit Wiring

1. Disconnect the tank unit (tan) wire at connector under rear floor of luggage compartment. See Figure 10-105 or 106. Plug the red test wire terminal into the connector and attach the black test wire to any convenient ground on the car.
2. Turn ignition switch on and move arm of test unit up and down against the stops while observing dash unit. If dash unit and wiring are okay, dash unit pointer will move freely from "Empty" to "Full" with movement of tester arm, indicating that trouble is in tank unit or the short wire leading to it.

b. Test of Dash Unit

1. Disconnect the tank unit at connector under rear floor of luggage compartment. See Figure 10-105 or 106. Attach the test unit black wire to ground.

2. Turn ignition on. Then with terminal of red test wire contacting the dash unit to tank unit terminal on printed circuit, move arm of test unit up and down against the stops. If dash unit is okay, the pointer will move freely from "Empty" to "Full" with movement of tester arm, indicating that trouble is in wiring or printed circuit. If pointer does not move or only moves part way, remove tan wire from printed circuit disconnect plug and repeat test on dash unit. If dash unit still does not operate properly, the printed circuit may be defective or the dash unit is faulty and should be replaced.

CAUTION: If the wrong terminal is contacted on dash unit, the rheostat in test unit may be damaged.

3. If, on the test of dash unit and tank unit wiring, (subpar. a) dash unit reads "Empty" or noticeably low at all times, look for a ground in the wiring circuit between dash unit and tank unit connector. If dash unit reads above "Full" or noticeably high at all times during test, look for points of high resistance or open circuit in wiring.

c. Test of Tank Unit

1. If tests given above indicate that the trouble is in the tank unit, remove the gasoline tank so that the tank unit may be cleaned and tested.
2. Before removing unit from gasoline tank clean away all dirt that has collected around the terminal; also make sure that insulation was in proper position over the terminal and wire. Road dirt, particularly calcium chloride, may have caused an electrical leak that threw the tank unit out of calibration.
3. After thorough cleaning and removal of tank unit, connect it to ground and to wire leading to

dash unit, and test in the same manner as when using tester. If tank unit tests okay it should be reinstalled in tank, otherwise it should be replaced with a new unit. When installing tank unit make certain that insulation is folded over the terminal and snapped over wire.

d. Removal and Installation of Dash Unit

1. Disconnect battery ground cable.
2. Remove the dash unit to instrument cluster printed circuit retaining screws. See Figure 10-63.
3. Remove dash unit.
4. To install dash unit reverse procedure.

e. Removal and Installation of Tank Unit

To replace tank unit it is necessary to remove gas tank as instructed in paragraph 3-10.

10-51 SPEEDOMETER

a. Speedometer Head

The speedometer head has a magnetic speed indicator and a gear driven odometer. It is driven by a flexible cable connected to a worm gear in the transmission rear bearing retainer. See Group 4 for gear ratios.

The speed indicating portion of speedometer operates on the magnetic principle. In the speedometer head is a permanent magnet which rotates at the same speed as the cable. This magnet exerts a pull on a speed cup causing it to move in direct ratio to the revolving magnet speed. A pointer is attached to the speed

cup spindle to indicate speed on the speedometer dial. A calibrated hair spring (part of speed cup) opposes the magnetic pull on the speed cup so the pointer indicates and pulls the cup and pointer to zero when car stops.

b. Checking Noisy Speedometer

1. Jack up rear wheels in safe manner and close car windows to exclude outside noises.

2. With transmission in direct drive, run slowly from 0 to 50 MPH and back to 0, noting speed range where noise appears.

3. Apply brakes and shift transmission to neutral or parking position, then run engine through same speed range as before.

4. If noise continued with transmission parts stationary, something other than the speedometer installation is at fault.

5. If noise disappeared with transmission stationary, check further for cause of noise by checking routing of speedometer cable as shown in Figure 10-84.

6. If cable routing was okay, next remove inner cable from casing. Lay inner cable on clean paper to keep dirt from cable lubricant. Reconnect empty casing to speedometer and recheck for noise at various speeds.

7. If noise still continues, noise is coming from transmission rather than speedometer.

8. If noise stopped with inner cable removed, speedometer or cable is at fault. Inspect and lubricate cable as described in subparagraph c.

c. Inspection and Lubrication of Speedometer Cable

If the speedometer installation appears to be noisy or the speed indicator wavers, inspect the cable casing for damage, sharp bends, or for being out of the supporting clips. If casing is in good condition and properly installed, remove cable for inspection and lubrication.

1. Disconnect speedometer cable casing at the speedometer head,

then pull cable out of upper end of casing.

2. Inspect cable for worn spots or breaks. Check cable for kinks by holding one end vertically in each hand and turning cable slowly; if cable is kinked, the loop will "flop." Replace a cable which has kinks or bent tips.

3. Coat the lower two thirds of the cable lightly with AC spec. 640 speedometer cable lubricant. If this is not available, #110 Lubriplate may be used. As cable is inserted into casing from upper end the lubricant will spread over its entire length.

4. When cable is connected to speedometer head make sure that the felt dampener washer is in place over the cable collar and that the cable tip seats properly in the head socket.

5. If speedometer noise is still present, install a new service speedometer cable assembly.

6. If this does not correct noise, have speedometer head checked by a UMS Service Station.

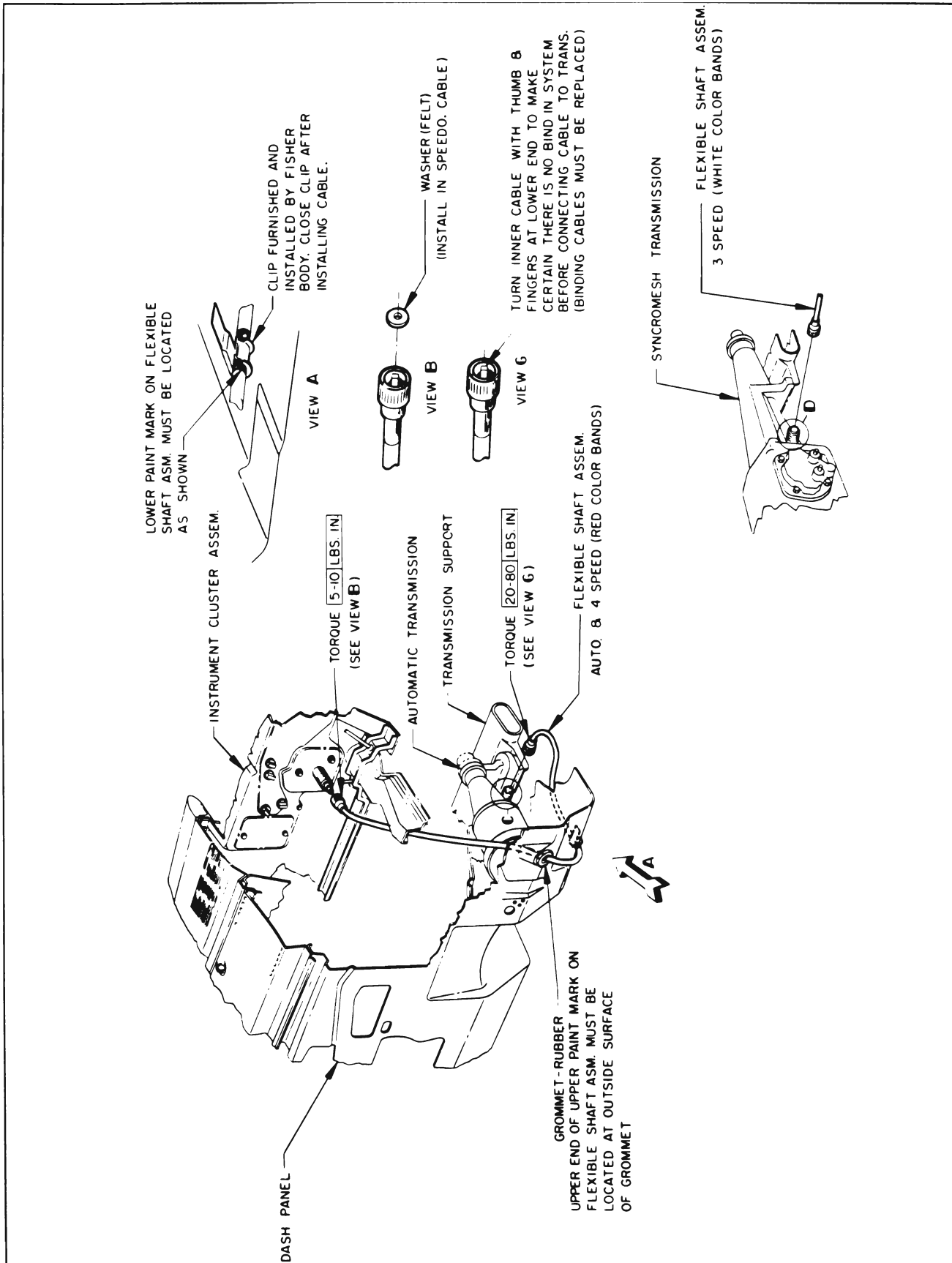

Figure 10-71—Speedometer Cable Installation