

SECTION 8-D

MAST JACKET AND TILT STEERING WHEEL ASSEMBLIES

CONTENTS OF SECTION 8-D

Paragraph	Subject	Page
8-22	Removal and Installation of Mast Jacket Assembly	8-54
8-23	Description of Tilt Steering Wheel	8-54
8-24	Tilt Steering Wheel Service Procedure	8-56

8-22 REMOVAL AND INSTALLATION OF MAST JACKET ASSEMBLY

a. Removal

1. Disconnect ground strap from battery.
 2. Disconnect rod from lower shift lever.
 3. Remove lower coupling pinch bolt on power steering cars. On manual steering, remove bolt and nut that retain clamp to coupling and slide clamp off coupling.
 4. Disconnect wiring harness connector from direction signal switch, horn wire that enters jacket and neutral safety switch.
 5. Remove the two nuts that retain jacket to lower edge of instrument panel. See Figure 8-75.
 6. Remove the screws that retain toe pan cover (located at lower end of jacket) to toe pan.
 7. Carefully pull jacket assembly up and out of opening in toe pan.
- CAUTION:** Use care not to damage shift indicator pointer.

b. Installation

1. Position mast jacket assembly through opening in toe pan.
2. Install steering shaft lower coupling on steering gear shaft and install lower coupling bolt as shown in Figure 8-9 or 8-26.

3. Attach jacket to instrument panel and to toe pan. See Figure 8-75.

NOTE: On power steering, lower coupling pins should extend $1/16''$ to $1/8''$ through steering shaft flange when mast jacket is installed. See Figure 8-71. On manual steering, the lower end of jacket should be $1\ 3/8''$ from end of lower coupling on all cars, except 4400 Synchronesh cars. On 4400 Synchronesh cars, there should be $1\ 1/2''$. See Figure 8-72.

4. Install wiring connectors on switches on jacket and horn wire.
5. Connect battery ground cable.
6. Check neutral safety switch adjustment and adjust if necessary.

8-23 DESCRIPTION OF THE TILT STEERING WHEEL

The optional tilt steering wheel is designed to give ease of entry and driver comfort through six different steering wheel angle positions on the 4400, 4600 and 4800 Series and seven different steering wheel angle positions on the 4700 Series. The steering wheel is locked in the selected position by a lever located to the left of the steering column. See Figure 8-76. This lever is pulled toward the steering wheel to disengage the lock and allow positioning the wheel at the desired angle.

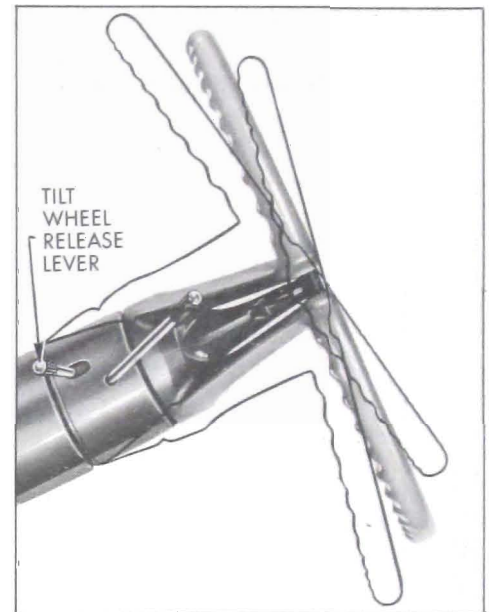

Figure 8-76—Tilt Steering Wheel Release Lever

The tilt steering assembly basically consists of an upper and lower steering shaft assembly with a universal type joint between them. See Figure 8-77. The joint has two Delrin spheres with a spring installed inside them to prevent any looseness in the joint. A support assembly is held to the mast jacket by a lock plate. The actuator is positioned over the upper steering shaft and is attached to the support by two pivot pins which allow up down motion between these parts. The upper and lower lock shoes which are retained to the actuator assembly, engage pins in the support. Two tilt springs are attached between the upper edge of the support and actuator.

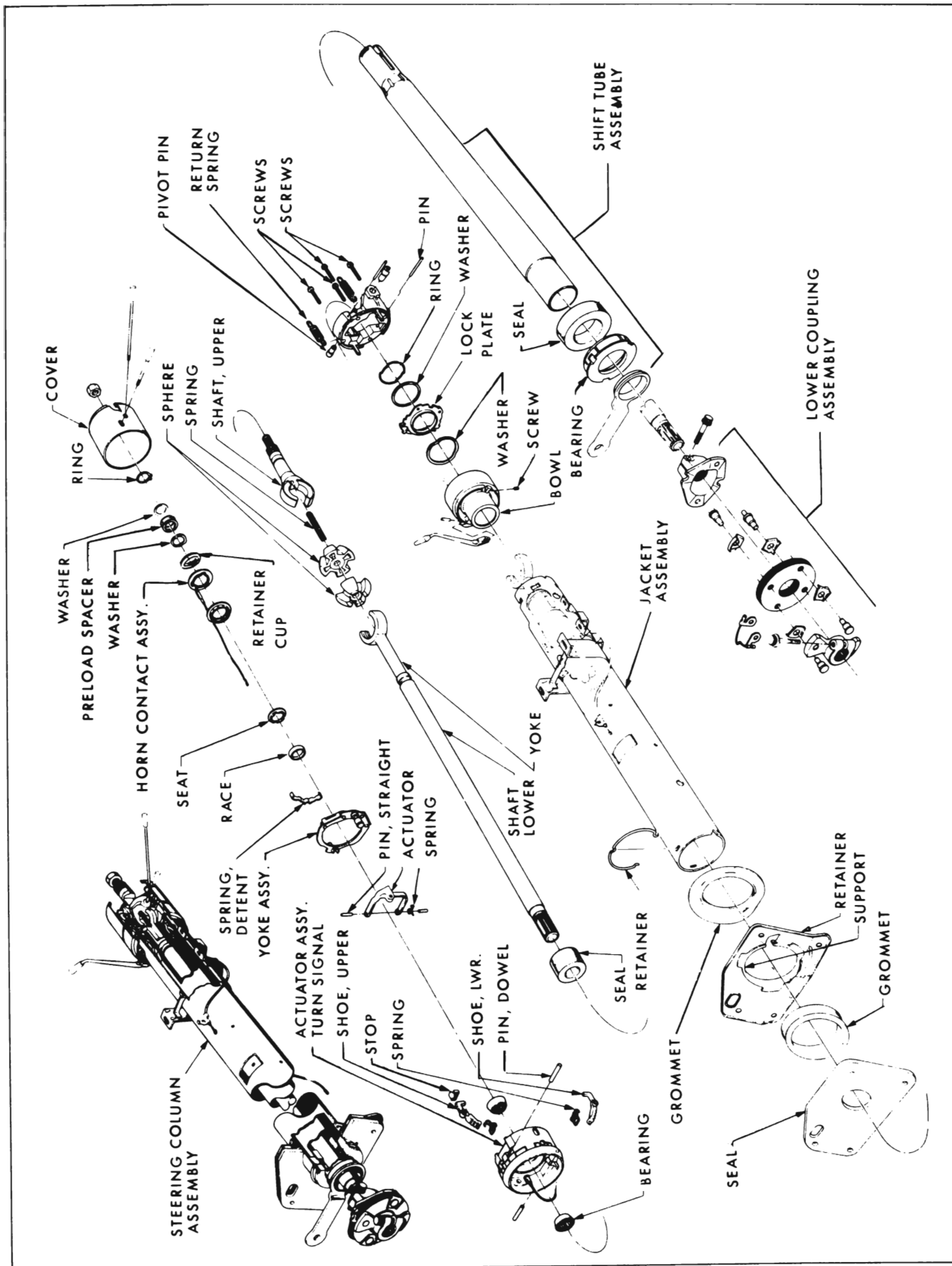

Figure 8-77—Exploded View of Tilt Steering Wheel

The upper shaft is secured in the actuator assembly by an upper and lower bearing. The bearings are preloaded by means of a bearing preload spacer. When the lever is released, the lock shoes will engage the pins in the support and hold assembly at angle desired.

When the tilt wheel release lever is moved upward the shoe release actuator causes the lock shoes to move inward and disengage the support. This allows the upper shaft which steering wheel is attached to and the actuator assembly to be set at a different position.

If no pressure is applied to the steering wheel when lever releases lock shoes, the tilt springs will position the steering wheel in its upper most position.

The 4400, 4600 and 4800 Series tilt wheel has a total of six positions. The 4700 tilt wheel has seven positions. Each position moves the steering wheel five degrees. The 4700 gains the extra position by use of a different upper lock shoe. This lock shoe allows the 4700 tilt wheel to move up one more position than the 4400, 4600 and 4800 tilt wheel.

8-24 TILT STEERING WHEEL SERVICE PROCEDURES

a. Removal of Actuator, Support and Steering Shaft Assemblies

The parts of the tilt wheel mechanism may be removed while the mast jacket assembly is installed in the car. If it is necessary to remove shift tube, the jacket assembly must be removed from car.

1. Remove steering wheel. Paragraph 8-5.

2. Remove direction signal switch from mast jacket. Disconnect control cable from switch.

3. Unplug horn ground wire connector where it enters mast jacket.

4. Carefully pry up horn contact and remove contact and wire from actuator.

5. Remove direction signal lever and tilt wheel release lever.

6. Remove actuator cover.

(a) Place Remover J-2180 inside cover.

(b) Thread two J-7004 slide hammers into J-21180 and carefully remove cover by applying force to one slide hammer at a time. See Figure 8-78.

7. Remove the upper shaft retainer ring using #2 Truarc Pliers J-4880. See Figure 8-79.

8. Remove washer, bearing preload spacer, rubber washer, retainer cup, seat, bearing inner race and upper bearing. See Figure 8-90. Discard preload spacer.

9. Remove turn signal detent spring and carefully remove actuator yoke.

10. Reinstall tilt release lever and position actuator assembly at the extreme up position.

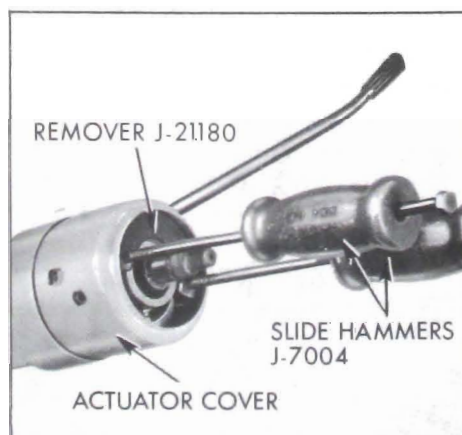

Figure 8-78—Removing Actuator Cover

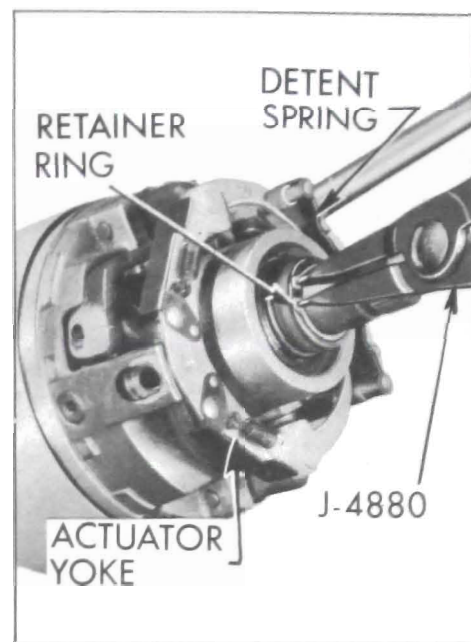

Figure 8-79—Removing Retainer Ring

11. Unhook upper ends of tilt springs by inserting a screwdriver in top coil of spring and prying upward, then disengage top loop of spring with another screwdriver. See Figure 8-80. View A shows removing spring on left side and View B shows removing spring on right side.

12. Remove the two pivot pins with Remover J-21179. See Figure 8-81. Thread stud of J-21179 into pin. Position remover as shown so that shift lever bowl will not be damaged. Hold stud and turn nut to remove pin.

13. Lift tilt wheel release lever to disengage lock shoes from the support and remove actuator assembly. See Figure 8-82. Remove tilt springs.

14. Remove lower bearing from steering shaft.

15. From the engine compartment remove the upper pinch bolt from the lower steering shaft flange.

16. Remove steering shaft assembly by pulling it up and out of mast jacket.

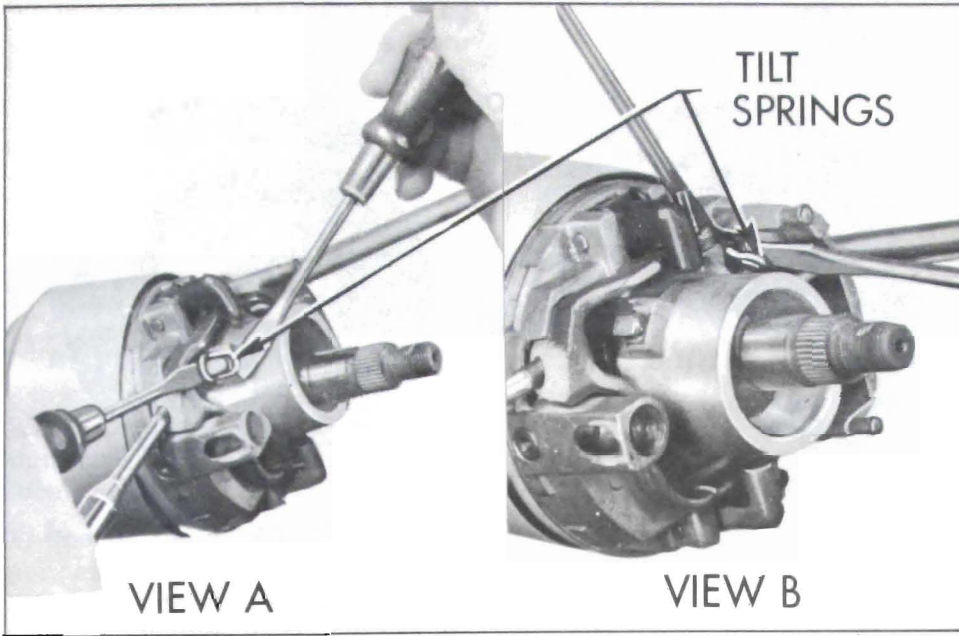

Figure 8-80—Removing Tilt Springs

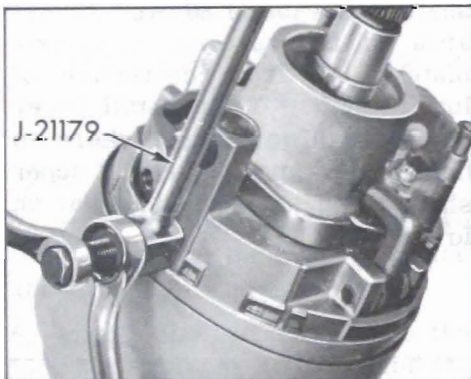

Figure 8-81—Removing Pivot Pin

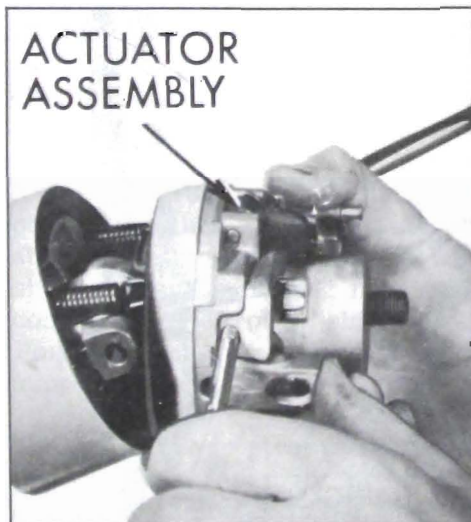

Figure 8-82—Removing Actuator Assembly

17. Remove the four support screws and then lift support off jacket.

b. Removal of Shift Bowl and Shift Tube

1. Remove mast jacket assembly from car. Paragraph 8-22.

2. Remove actuator, support and steering shaft assemblies from mast jacket. Subparagraph a.

3. Remove the shift tube retainer ring and washer from the top of shift tube. See Figure 8-83.

4. Remove the shift tube bearing retainer from the lower end of the mast jacket.

5. Remove the shift tube downward through column with two Slide Hammers J-7004 and Tool J-21180, driving against lower shift lever. See Figure 8-84.

6. Remove lock plate, wave washer and shift bowl from upper end of the mast jacket.

c. Assembly of Shift Bowl and Shift Tube

1. Install shift bowl on the mast jacket, then the wave washer lubricated with front wheel bearing

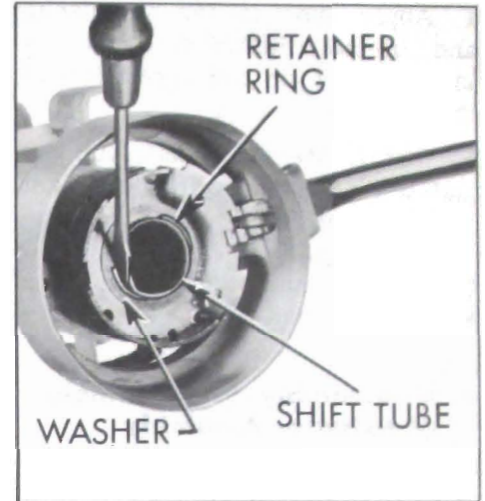

Figure 8-83—Removing Shift Tube Retainer Ring

lube over the mast jacket and then slide the lock plate into position through the opening in the mast jacket.

2. Install the shift tube assembly with felt seal into the mast jacket from the lower end of the jacket.

3. Position the Delrin bearing into the lower end of the mast jacket so that slots in bearing line up with openings in jacket and install the retaining ring.

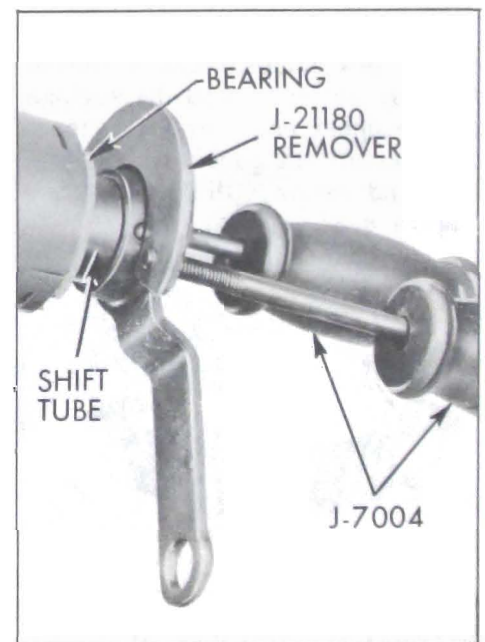

Figure 8-84—Removing Shift Tube

4. Apply lube to thrust washer and install the washer and retaining ring on the upper end of the shift tube.
5. Install steering shaft support and actuator assemblies in mast jacket. Subparagraph f.
6. Install mast jacket in car. Subparagraph 8-22.

d. Disassembly and Assembly of Actuator Assembly

The actuator, lock shoes and springs may be replaced separately. The shoe release actuator is serviced only with the actuator. See subparagraph a for removal of these parts.

1. Drive lock shoe pins out of actuator and remove shoes and springs. The upper shoe has a rubber stop on it. See Figure 8-85.
2. If necessary remove control cable from actuator.
3. If removed, install the turn signal switch control cable on the bell crank in the turn signal actuator mounting cable loop inboard. Install cable bracket screw.
4. If lock shoes were removed from actuator, install the springs on the upper end over lock shoes, then install the shoes in the actuator and retain with the pins. See Figure 8-86.

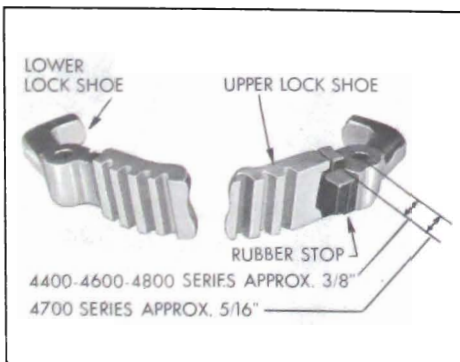

Figure 8-85—Lock Shoes

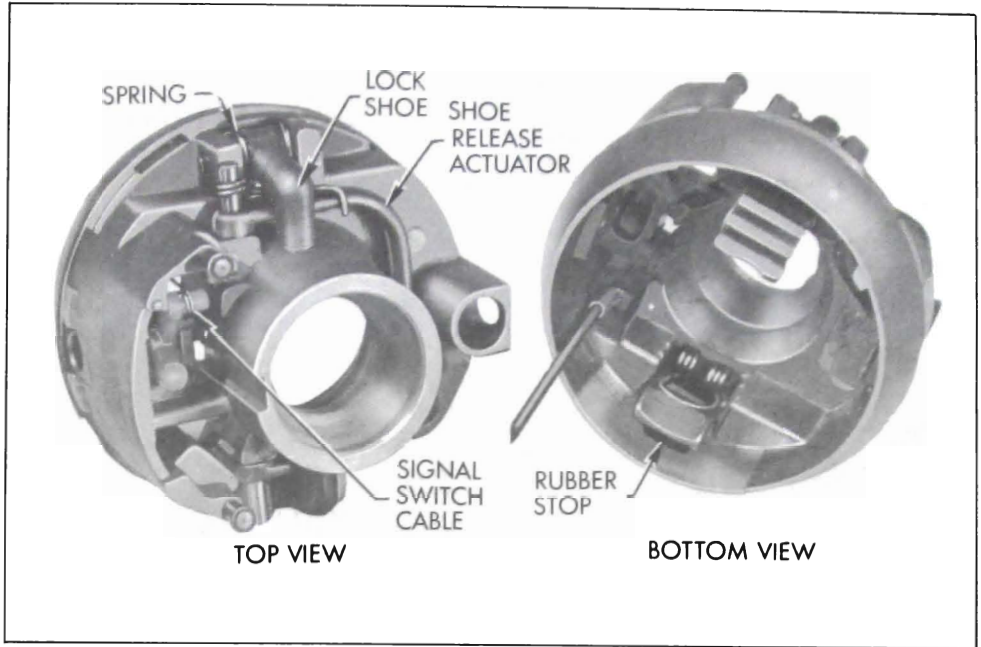

Figure 8-86—Actuator Assembly

NOTE: The upper lock shoe must have the rubber stop installed.

e. Disassembly and Assembly of Steering Shaft Assembly

See subparagraph a for removal of shaft assembly.

1. Turn upper shaft slightly from centerline of lower shaft.
2. Using a narrow bladed screwdriver, compress joint preload spring enough to remove from upper shaft, then remove spring from centering spheres. See Figure 8-87.
3. Turn upper shaft 90° from centerline of lower shaft and remove shaft over flats of centering sphere.
4. Remove the sphere from the upper shaft by rotating so sphere flats align with shaft socket.
5. Apply front wheel bearing lube to the centering spheres and the steering shaft sockets.
6. Place the centering spheres in the upper shaft socket.
7. Turn the spheres so the lower

shaft can be installed over the flat area of the spheres. (Approximately 90° from centerline of lower shaft.) Then install lower shaft socket over the sphere so that locating mark on end of upper shaft is on same side as flat on lower shaft.

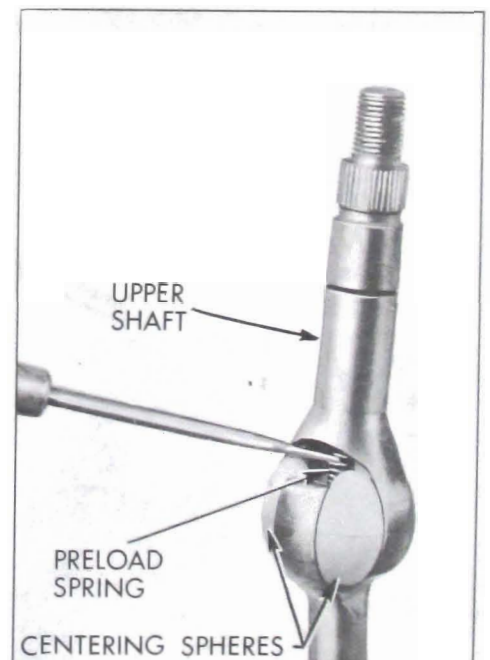

Figure 8-87—Removing Joint Preload Spring

8. Insert the joint preload spring through centering spheres into lower shaft. Using the upper shaft to hold the spring in place and a screwdriver in the other hand, carefully feed spring into shaft joint. See Figure 8-88.

f. Installation of Support, Steering Shaft and Actuator Assemblies

When assembling parts, apply a thin coat of front wheel bearing lube to all friction parts.

1. Install the support on the upper end of the mast jacket and install the four attaching support screws. Torque screws to 25 in. lb. Torque larger screws first.

2. Install the steering shaft assembly into the mast jacket.

3. Install steering shaft seal on lower end of steering shaft.

4. Place the lower bearing on upper steering shaft.

5. Snap the lower ends of the two tilt springs on the support spring anchor.

6. Install the tilt lever into the lock shoe release actuator and install horn wire and contact assembly in actuator assembly.

7. Apply front wheel bearing lube on lock shoes and on frictional surfaces at actuator assembly including surfaces where actuated contacts support. Move the tilt lever up slightly to prevent the lock shoes from engaging the support pins, then install the actuator assembly over the steering shaft, carefully feeding horn and control wire through shift bowl. Position actuator assembly on support. See Figure 8-82.

8. Apply lube to pivot pins. Align the actuator assembly pivot pin holes with the holes in the support assembly and install pivot pins. Pins should be flush with edge of actuator.

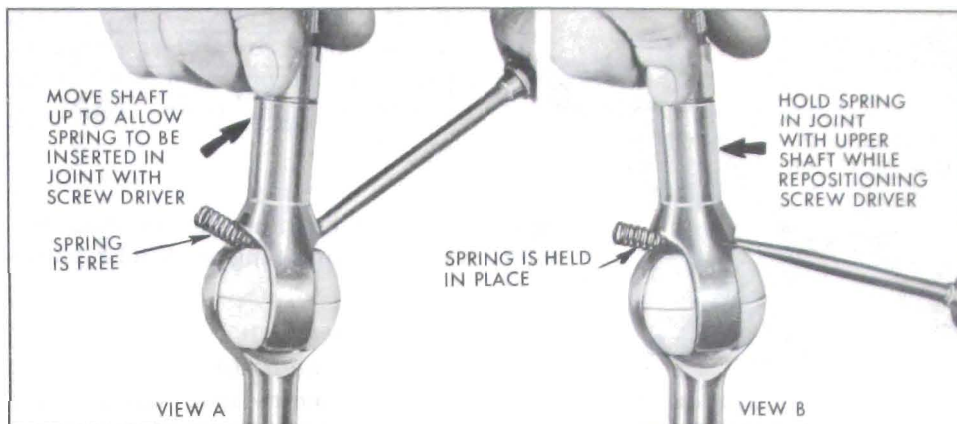

Figure 8-88—Installing Joint Preload Spring

9. Raise tilt release lever and position actuator at extreme up position.

10. Install the upper ends of the two tilt springs using Tool J-21181 spring installer. See Figure 8-89.

11. Install the turn signal actuator yoke and detent spring. Be sure yoke engages turn signal cable operating lever in actuator.

12. Install the upper steering shaft bearing, bearing inner race, seat, retainer cup (lip side up), rubber washer, new bearing preload spacer, washer and retainer ring on upper steering shaft. See Figure 8-90.

13. Using the #2 Truarc Pliers J-4880, install the retainer ring on upper shaft. Place Installer J-21179 with cut out or slot on retainer ring as shown in Figure 8-91. Install the steering shaft nut and tighten until the cut out in J-21179 is in line with the upper edge of the retainer ring groove in shaft. See Figure 8-91. Remove nut and J-21179 and allow ring to seat in groove in shaft.

IMPORTANT: Care must be used when compressing preload spacer in Step 13 so that bearings will be properly preloaded.

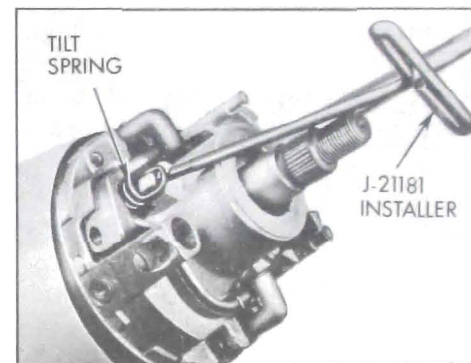

Figure 8-89—Installing Tilt Springs

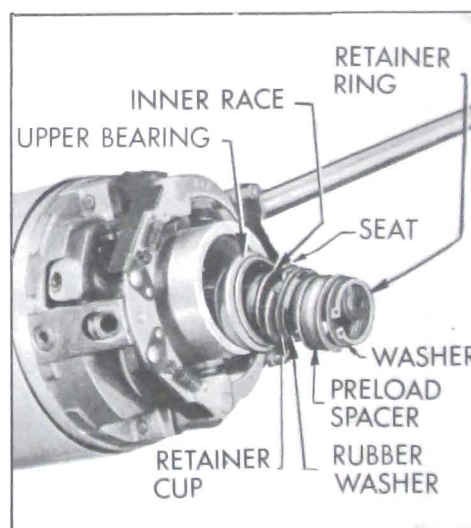

Figure 8-90—Installing Bearing Preload Parts

NOTE: If mast jacket is removed or lower end of steering shaft is free, check torque of steering

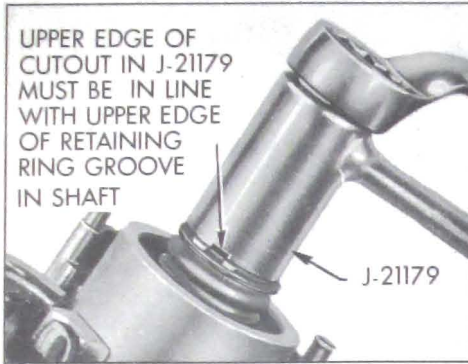

Figure 8-91—Compressing Preload Spacer

shaft to see if bearing preload is correct using Torque Wrench J-5853. Torque should be 35 to 45 inch ounces in all tilt wheel positions. If torque is too high, remove retainer ring from upper shaft and repeat Step 13 being sure to properly compress spac-

er. If torque is too low, obtain another new bearing preload spacer and properly install being careful not to over compress spacer.

14. Seat horn contact in actuator. Coat contact ring with lubriplate.

15. Remove tilt release lever. Align the actuator cover so that tang on cover lines up with its slot in actuator. Carefully install cover on actuator using a block of wood.

16. Install the tilt release and direction signal turn levers in actuator.

17. Plug horn wire together at mast jacket.

18. Install steering wheel. Paragraph 8-5.

19. Install direction signal switch as follows:

a. Position tilt wheel in full down position. Locate switch pin in center position.

b. Place direction signal lever in off position, then install control wire loop over switch operating pin.

c. Attach cable wire clamp to switch.

d. Assemble switch to mast jacket.

20. Install lower coupling pinch bolt and tighten to 25 ft. lbs.

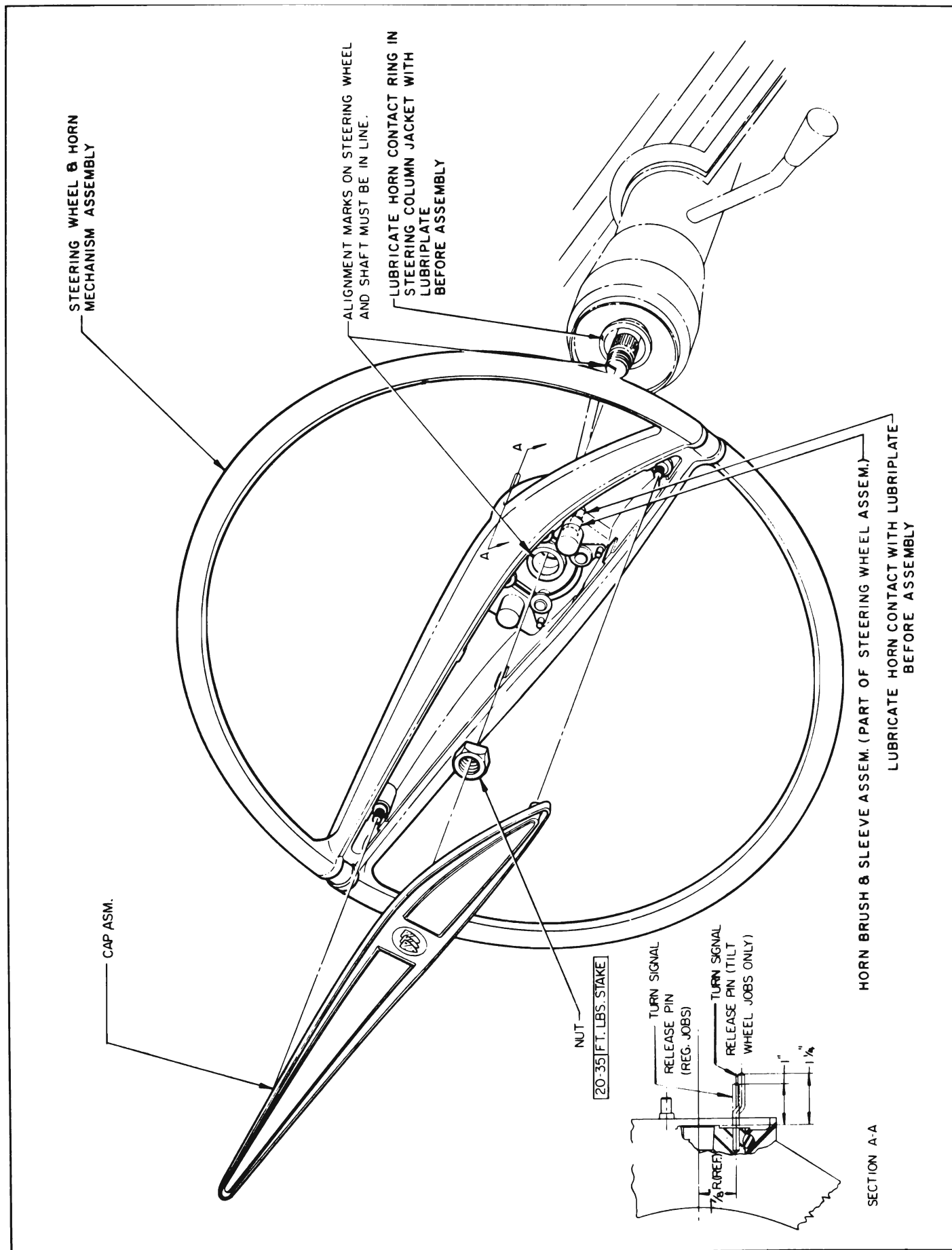

Figure 8 -92—Steering Wheel Installation