

## SECTION 8-C MANUAL AND POWER STEERING LINKAGE

### CONTENTS OF SECTION 8-C

Paragraph	Subject	Page
8-19	Steering Linkage Specification . . . .	8-44
8-20	Description of Steering Linkage . . .	8-44
8-21	Adjustment of Steering Linkage Idler Arm . . . . .	8-45

### 8-19 STEERING LINKAGE SPECIFICATIONS

#### a. Tightening Specifications

Use a reliable torque wrench to tighten the parts listed to insure proper tightness without straining or distorting parts. These specifications are for clean and lightly lubricated threads only; dry or dirty threads produce increased friction which prevents accurate measurement of tightness.

Part	Location	Thread Size	Torque Ft. Lbs.
Bolt & Nut	Tie Rod Clamp . . . . .	3/8-24	20-27
Bolt	Idler Arm Support to Frame . . . . .	3/8-24	40-50
Nut	Tie Rod Ball Stud to Steering Arm & Intermediate Rod . . . . .	1/2-20	50-60
Nut	Pitman & Idler Arm to Intermediate Rod . . . . .	1/2-20	50-60
Nut	Pitman Arm to Pitman Shaft . . . . .	7/8-14	90-110
Bushing	Idler Arm (Saginaw) . . . . .	7/8-11	100-115

#### b. Steering Linkage Specifications

	Specification
Type . . . . .	Parallelogram
Make . . . . .	
Manual Steering . . . . .	Saginaw Steering
Power Steering . . . . .	Saginaw Steering & Thompson Products
Turning Circle Diameter (Curb to Curb)	
Series 4400-4600 . . . . .	45.9 ft.
Series 4700 . . . . .	43.6 ft.
Series 4800 . . . . .	47.6 ft.
Toe-in, Caster, Camber, etc. . . . .	See Group 7

### 8-20 DESCRIPTION OF STEERING LINKAGE

The parallelogram type steering linkage is used to connect both front wheels to the steering gear pitman arm. The right and left tie rods are attached to a forged intermediate rod by ball studs. The left end of the intermediate rod is supported by the pitman arm and the right end by an idler arm which pivots on a support attached to the frame. The pitman and idler arms are always parallel with each other and move

through symmetrical arcs. There are three different linkage setups. Two manufactured by Saginaw Steering, one for power gears and the other for manual gears. The third is manufactured by Thompson Products and is used only for power gears. See Figures 8-67 and 8-68.

The inner and outer tie rod ends, the idler arm support bushing and the pitman and idler arm ball studs are of the permanent lubricated design and do not require periodic lubrication, on all linkage assemblies.

However, all the ball studs except the pitman arm and idler arm ball studs have removable plugs. If a squeak develops in a stud on a high mileage car, the plug may be removed and a grease fitting (1/4 - 28) installed and stud lubricated as instructed in paragraph 1-3.

When assembling the idler arm to support it must be adjusted as shown on Figure 8-67. There is no adjustment of the Thompson idler arm and support as these parts are serviced as an assembly.

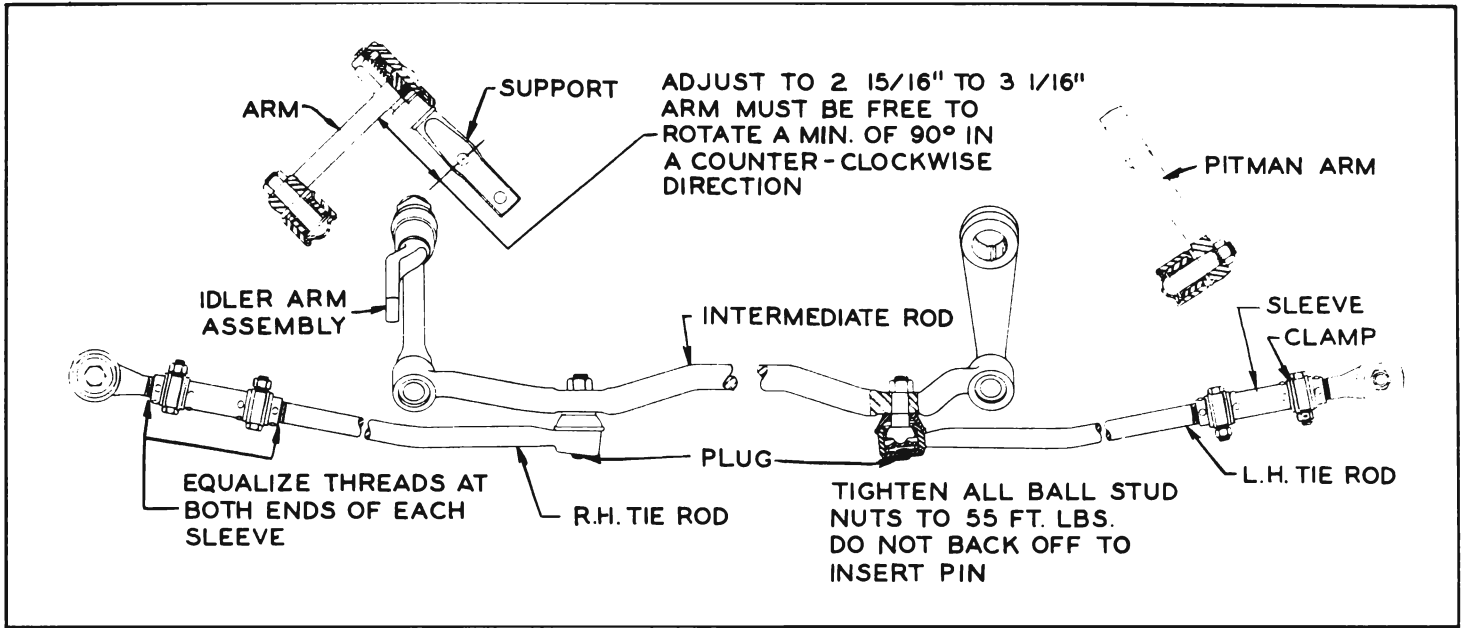

Figure 8-67—Manual and Power Steering Linkage—Saginaw

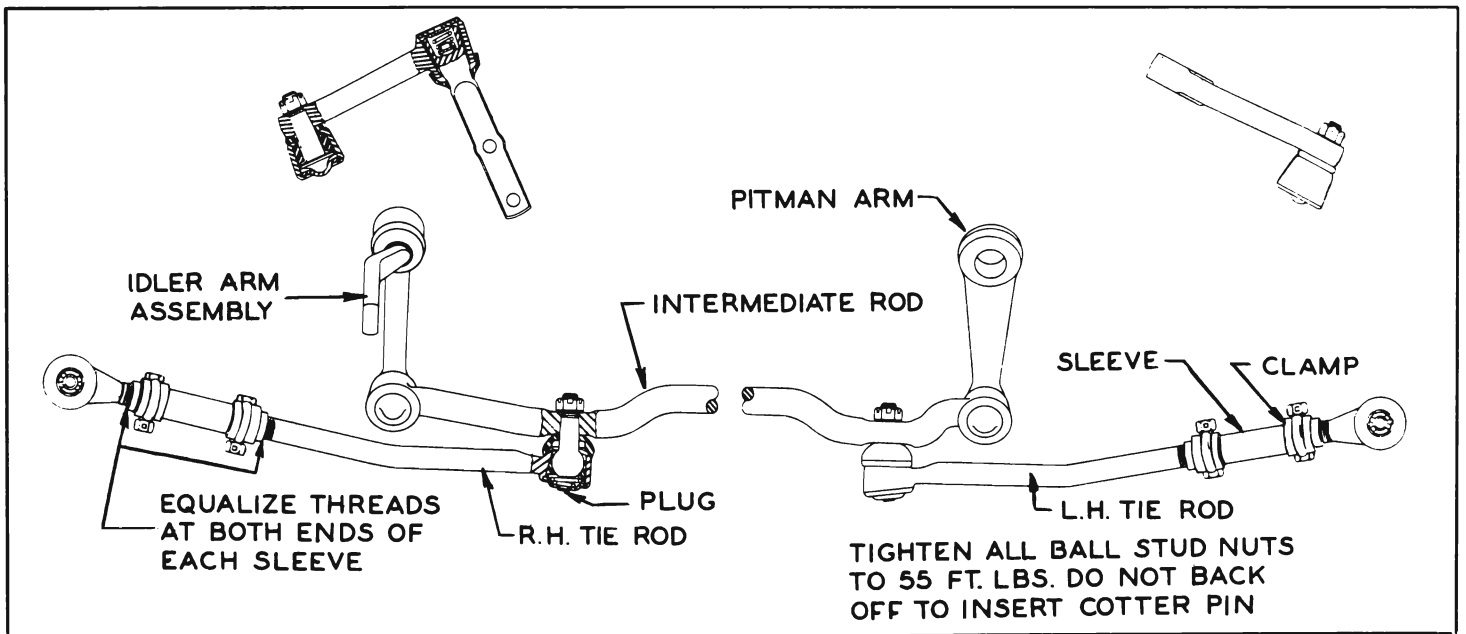

Figure 8-68—Power Steering Linkage—Thompson

The Saginaw manual linkage is the same as the Saginaw power steering linkage, except the manual linkage has a different pitman arm to fit the manual gear pitman shaft.

### 8-21 ADJUSTMENT OF STEERING LINKAGE IDLER ARM

The Thompson steering linkage

does not require any special adjustment as the idler arm and support assembly is self-adjusting.

The Saginaw linkage requires proper location of the idler arm on its support so that the idler arm ball socket will be level with the pitman arm ball socket. The support must be threaded into the idler arm bushing until the dis-

tance from the center of the support lower bolt hole to the nearest face of the idler arm is 2-15/16" to 3-1/16", as shown in Figure 8-67 and 8-69. When the idler arm is installed on support, it must be free to rotate a minimum of 90 degrees in a counterclockwise direction.

**IMPORTANT:** If the Saginaw idler arm support is dismantled

from the frame for other work, wire the support to the idler arm so that it cannot turn from its existing position and possibly change the toe-in of the front wheels.

See Group 7 for adjustment of tie rods to obtain proper toe-in of front wheels.

When disconnecting any of the

steering linkage ball studs, use Puller J-5504 where possible. If puller will not work, use Remover J-3295 and firmly support the member that stud is being removed from.

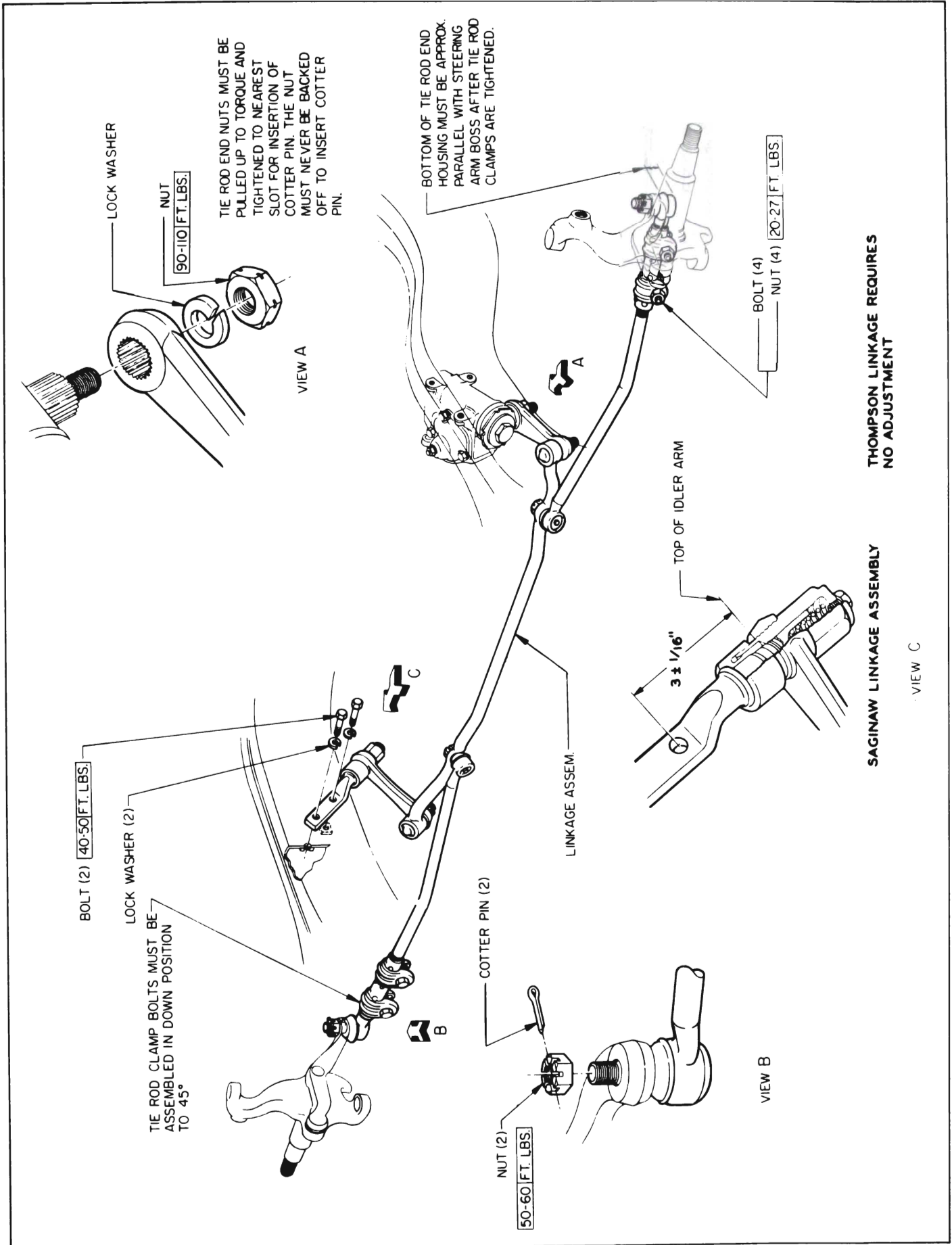
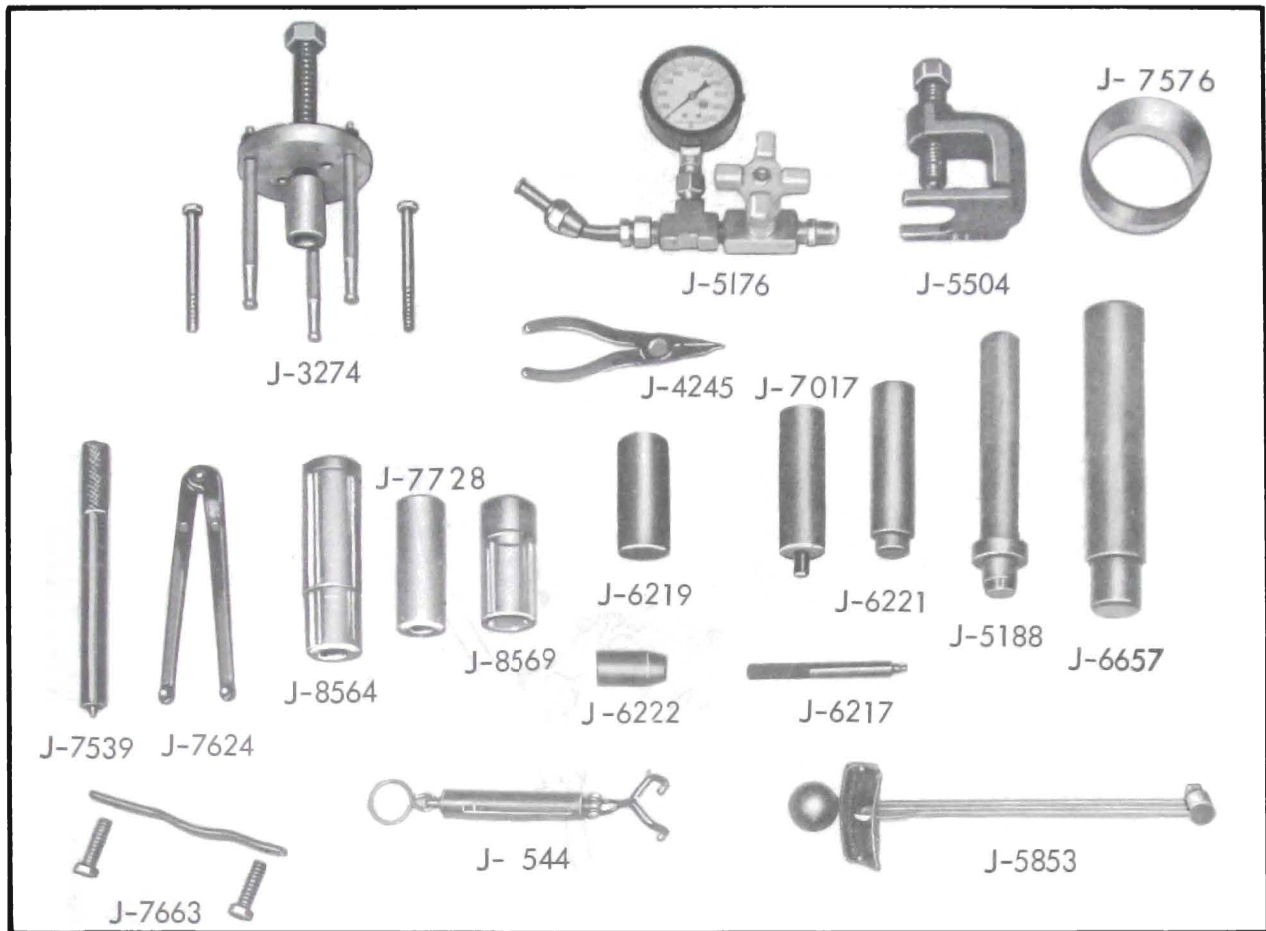

Figure 8-69—Steering Linkage Installation



STEERING TOOLS

- J- 544 Steering Gear Tension Scale 0-4 lbs.
- J-3274 Steering Wheel Puller
- J-4245 Trueare Pliers
- J-5176 Testing Gauge, Oil Pressure
- J-5188 Valve Cover Seal Installer
- J-5504 Pitman Arm Puller
- J-5853 0-100 in. lb. Torque Wrench
- J-6217 Valve Connector Seal Installer
- J-6219 Steering Gear Pitman Shaft Oil Seal Installer
- J-6221 End Cover Bearing Remover and Installer (Adjuster Plug Needle Bearing)
- J-6222 End Cover Seal Protector (Stub Shaft Protector)
- J 6657 Pitman Shaft Needle Bearing Remover and Installer
- J-7539 Power Steering Gear Ball Retaining Tool
- J-7624 Power Steering Gear Adjustable Spanner Wrench
- J-7663 Power Steering Pump End Plate Installer
- J-8564 Worm Shaft Oil Seal Installer , Manual Gear
- J-8569 Pitman Shaft Oil Seal Installer ,Manual Gear
- J-7017 Power Steering Oil Pump Shaft Seal Installer
  
- J-7728 Power Steering Pump Seal Installer With Shaft in Place
- J-7576 Teflon Ring Compressor

Figure 8-70—Steering Gear and Linkage Special Tools

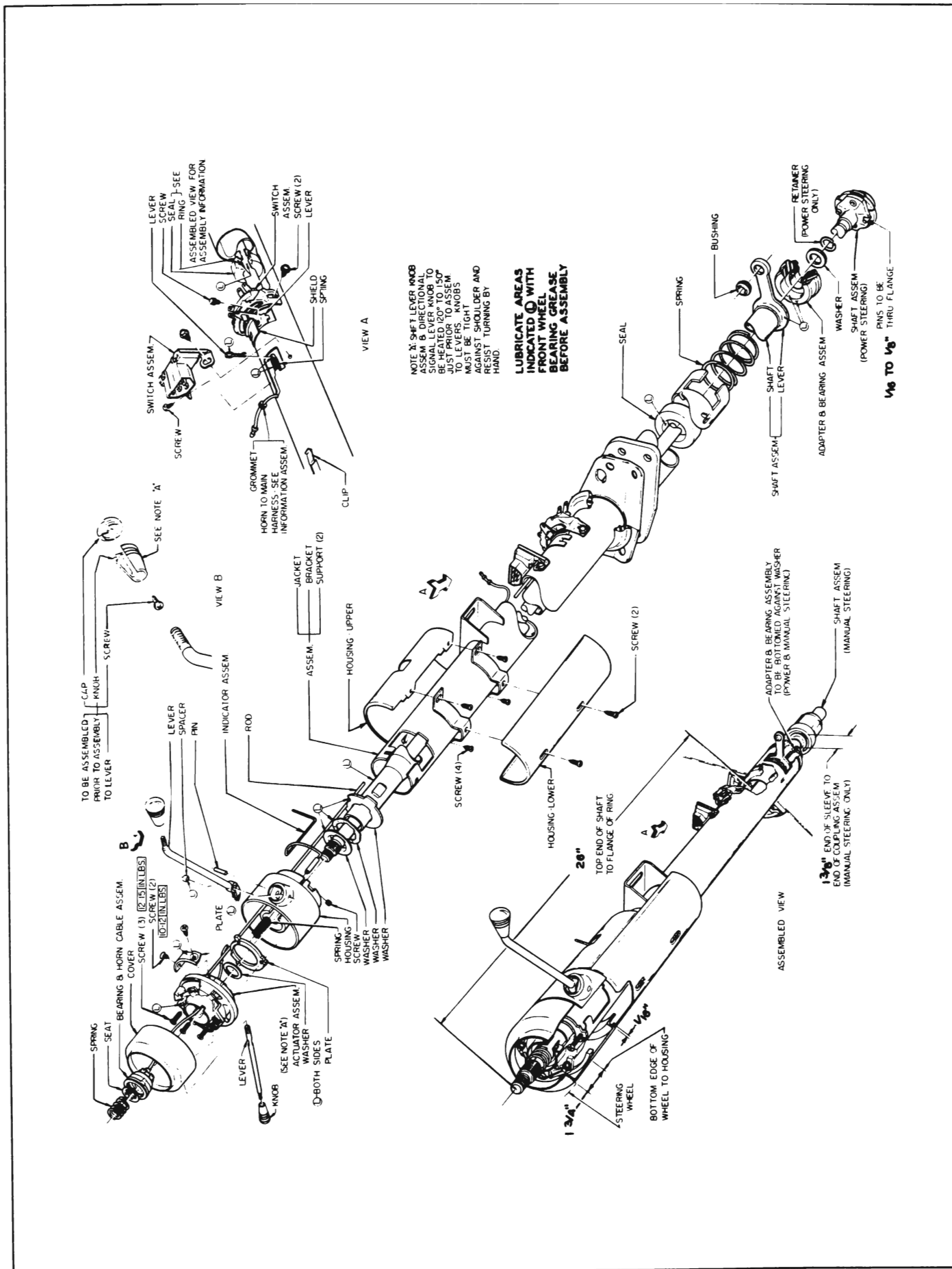

Figure 8-71—Steering Column Jacket and Transmission Control Shaft Assembly—4400-4635-4800 with Automatic Transmission

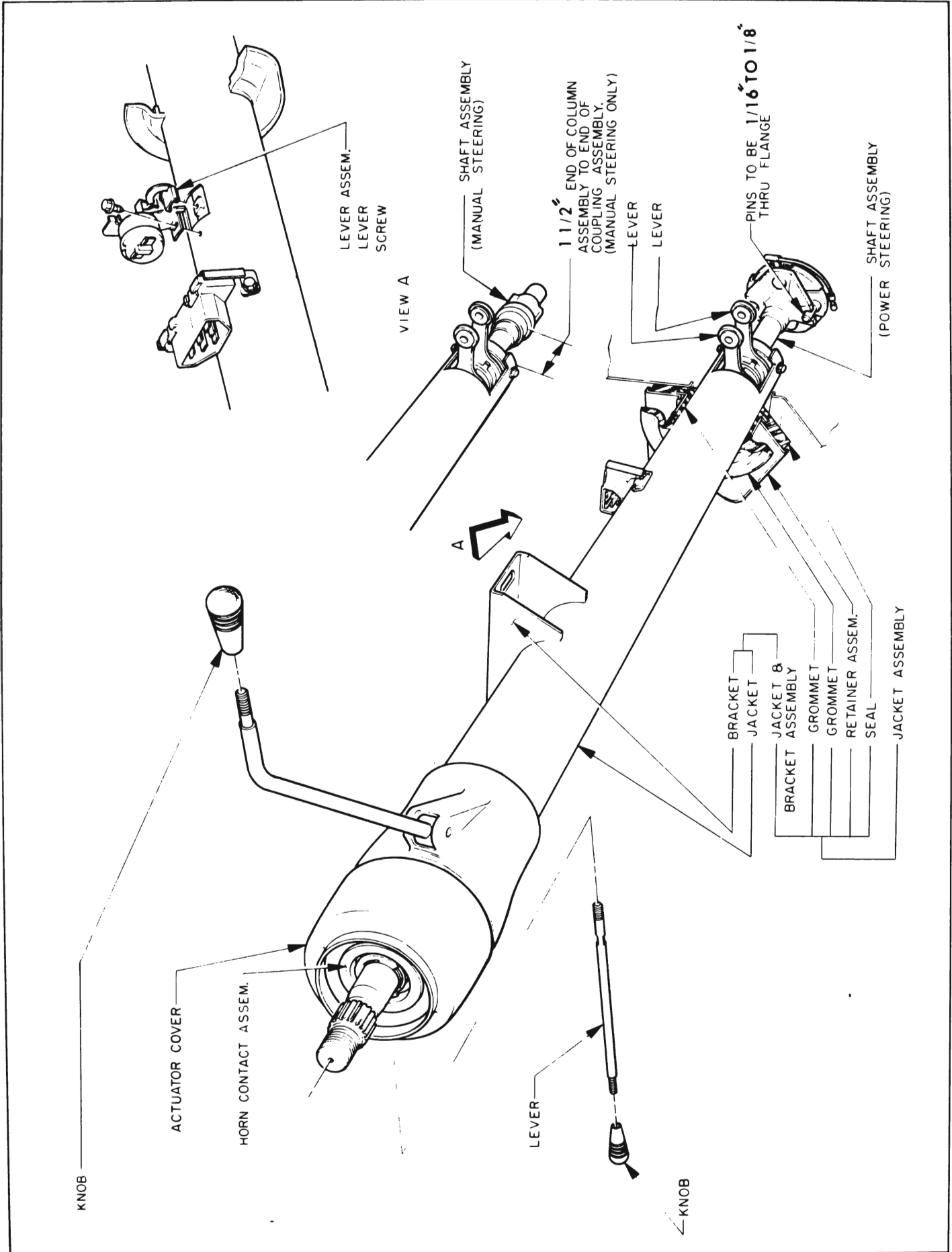

Figure 8-72—Steering Column and Transmission Control Shaft Assembly—4400 Three Speed Synchronmesh Transmission

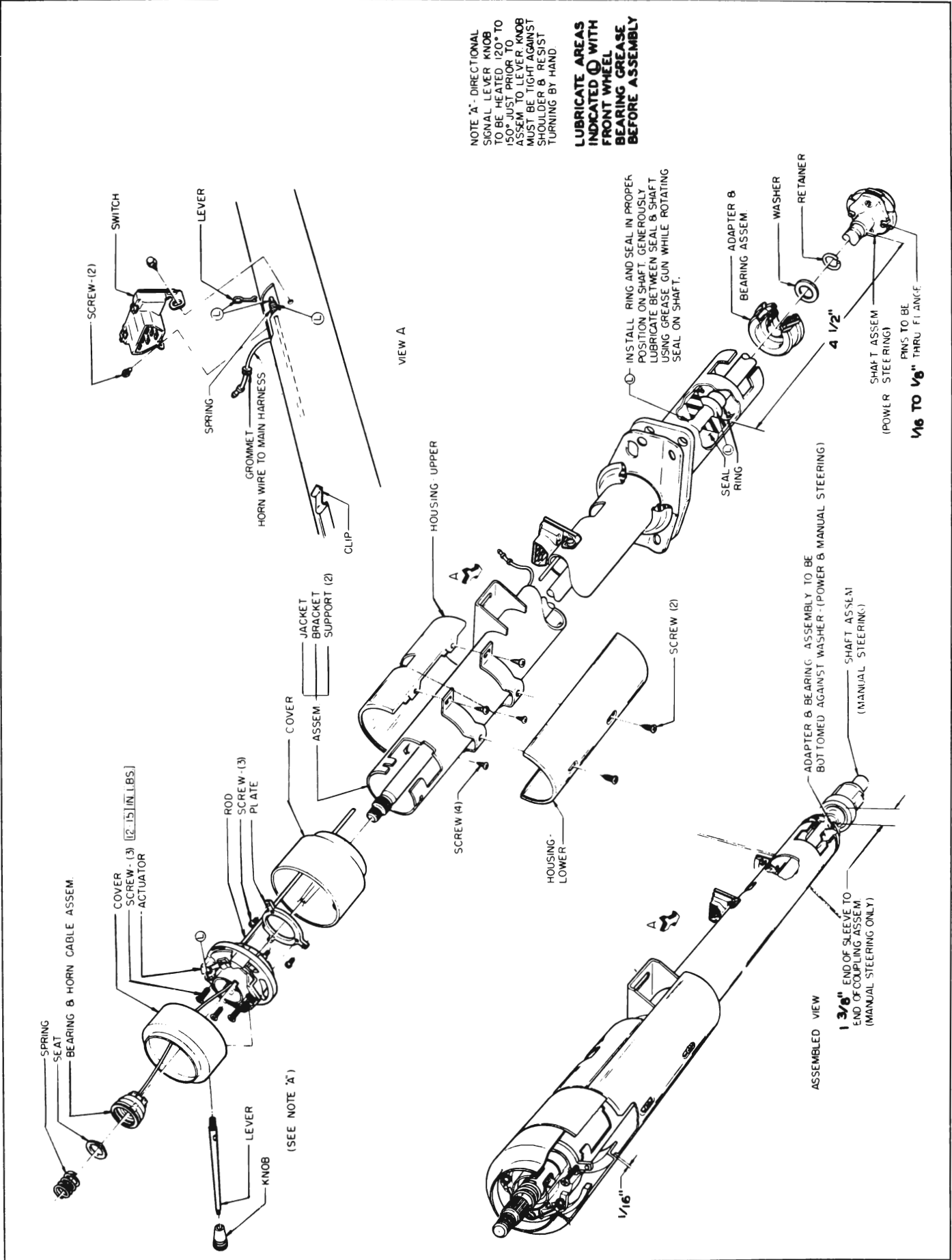

Figure 8-73—Steering Column Assembly—4400—Four Speed Transmission and 4639, 4647, 4667 Series



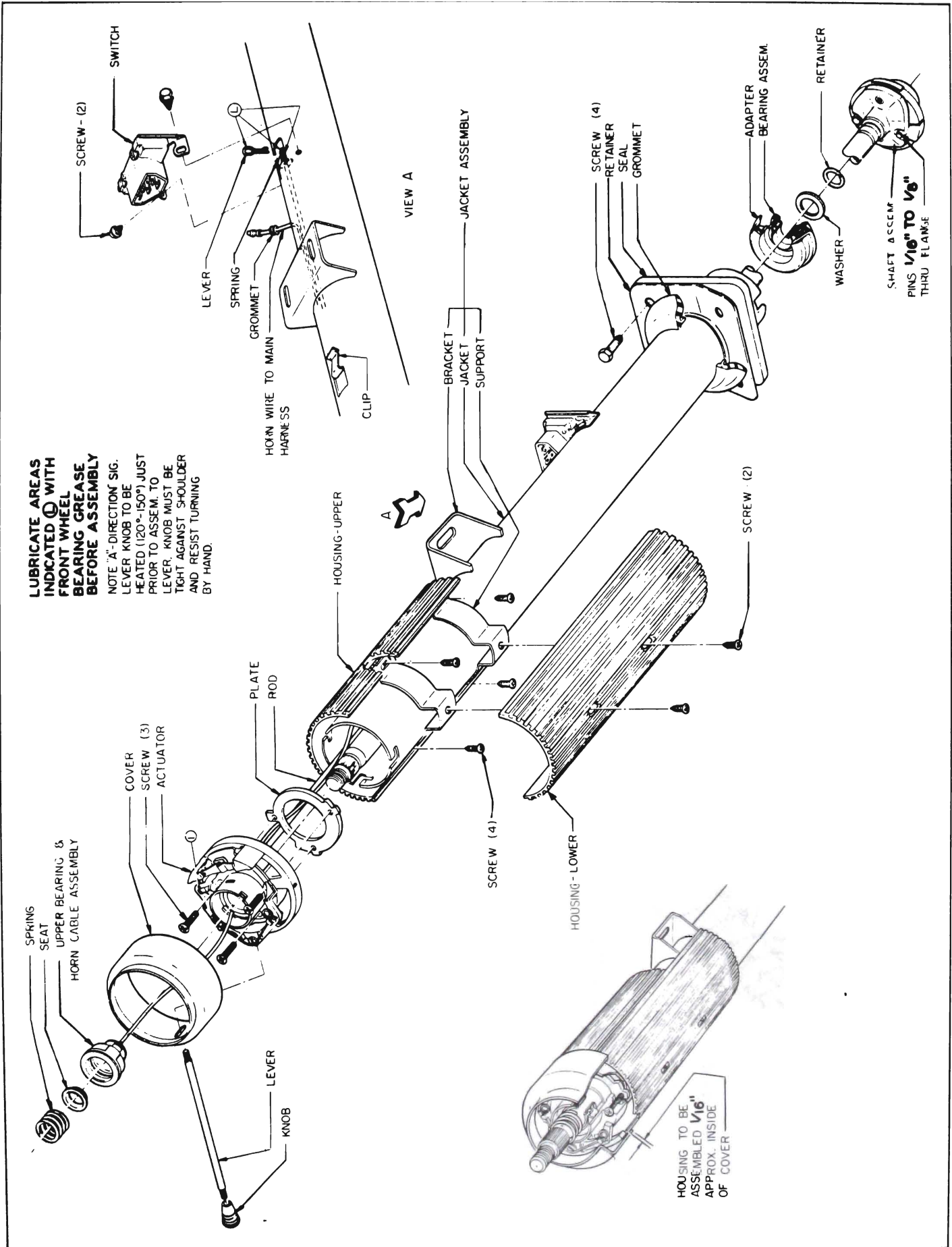

Figure 8-74—Steering Column Assembly—4700 Series

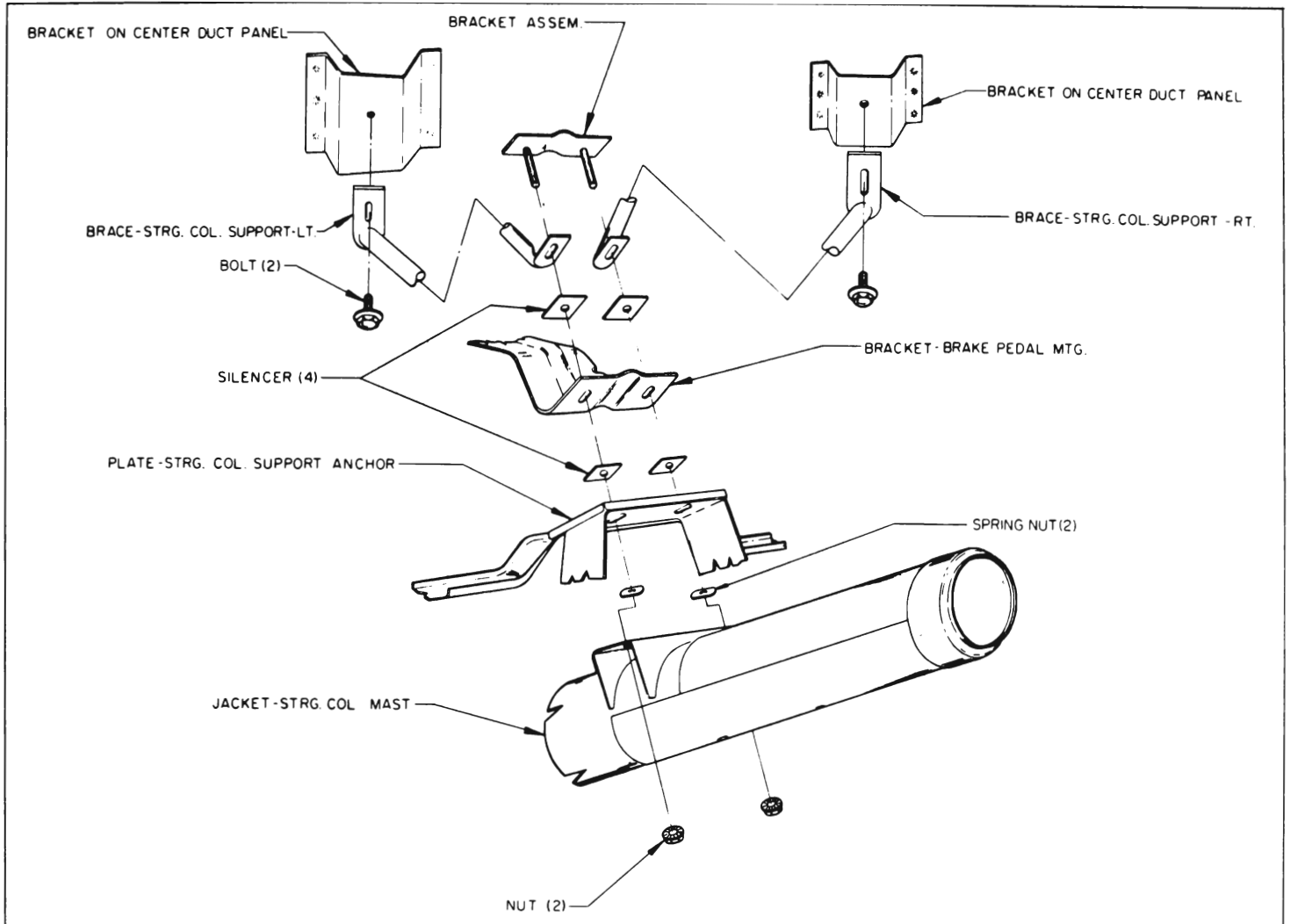

Figure 8-75—Steering Column Installation—Upper End