

SECTION 6-C

POSITIVE TRACTION DIFFERENTIAL

CONTENTS OF SECTION 6-C

Paragraph	Subject	Page	Paragraph	Subject	Page
6-9	Description of Positive Traction Differential	6-18	6-11	Positive Traction Differential Service Procedures	6-20
6-10	Lubrication of Positive Traction Differential	6-20			

6-9 DESCRIPTION OF POSITIVE TRACTION DIFFERENTIAL

a. General Description

The Positive Traction (non-spin) Differential is optional equipment on all series Buicks. Its primary advantage is that it reduces the possibility of the car becoming stuck under adverse driving conditions. Unlike the conventional differential assembly, when one wheel is on a slippery surface the car will still move forward since both wheels are automatically locked together and rotating at the same speed, allowing the wheel on dry surface to provide the necessary traction.

A secondary advantage of the Positive Traction Differential is that bumps do not adversely effect rear wheel action. During power application, with a conventional differential, when one rear wheel hits a bump and bounces clear of the road, it spins momentarily. When this rapidly spinning wheel contacts the road again, the sudden shock may cause the car to swerve. This is also hard on the complete drive train and tires. With a non-spin differential, the free wheel continues rotating at the same speed as the wheel on the road, thereby minimizing the shock and its resulting swerve.

The Positive Traction Differential consists of a different type of differential case assembly which is used in place of the conventional

case assembly. All rear axle parts are identical.

b. Operation

The Positive Traction Differential has pinion gears and side gears which operate in a manner similar to those in a conventional differential. However, behind each side gear is a side gear ring and a clutch pack whose function is to hold the side gears to the case under certain driving conditions, which in effect locks both axle shafts together to turn as one. In order to provide room to assemble these clutches the differential case is split into two halves (the ring gear flange half and the cover half) which bolt together.

The mechanism that actuates the clutches consists of four pinion gears positioned in the case on two cross shafts which are at right angles to each other. Both ends of the shafts have bevelled surfaces which mate with ramps in the case. See Figure 6-39.

Until force is applied to the differential case by the drive pinion and ring gear, the two cross shafts are down in the grooves in the differential case and the clutches are not applied. However, when force is applied upon acceleration with the weight of the vehicle proportionally on the rear wheels and the friction of the rear wheels against a surface, the side gears which are splined to the axles exert a force to the pinion gears and to the cross shafts

forcing the cross shaft up the ramps in the case. When the cross shafts ride up the ramps they carry the pinion gears with them against the side gear ring forcing this against the clutch pack, thus compressing the clutch pack against the differential case and locking the two axles together.

Although one wheel may be slipping in mud, snow or on ice, there is usually enough friction on this slipping wheel to start the above process. In extreme cases such as wet ice, which is probably the slipperiest road surface one might encounter, there may not be enough friction on the slipping wheel to lock the axles together. This can be overcome by lightly applying the parking brake. This added resistance to the slipping wheel can cause the pinion shafts to climb their ramps and lock the axles together. This gives the wheel on solid ground sufficient power to pull the car away from the obstacle.

Each clutch pack consists of three clutch plates which are keyed to the differential case by external lugs, and two clutch discs which are splined internally to the side gear ring. The gear ring is splined to the side gear which is in turn splined to the axle shaft. Whenever a load is applied to the differential, each side gear ring is forced outward, squeezing its clutch pack against the differential case. See Figure 6-40.

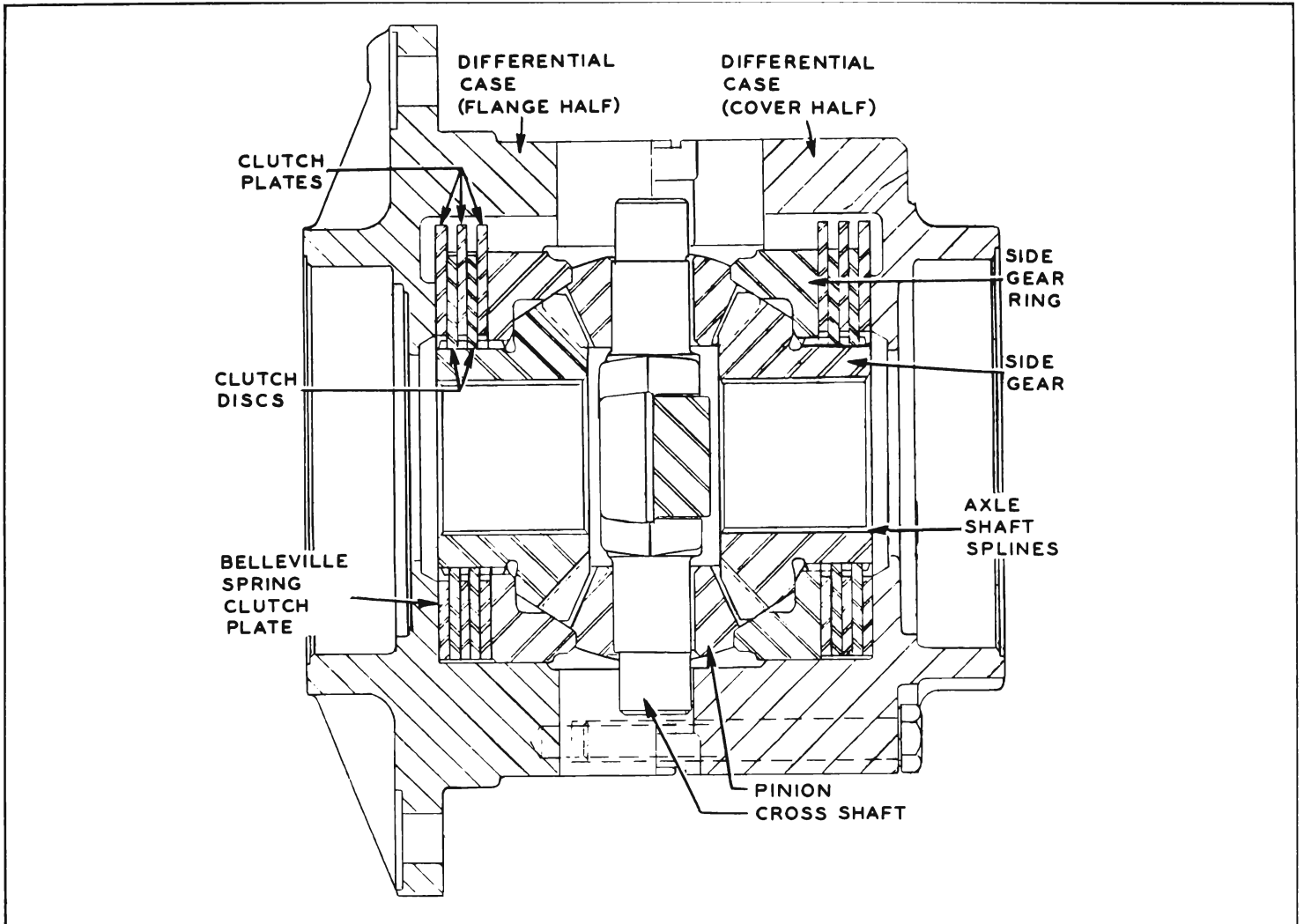

Figure 6-38—Positive Traction Differential

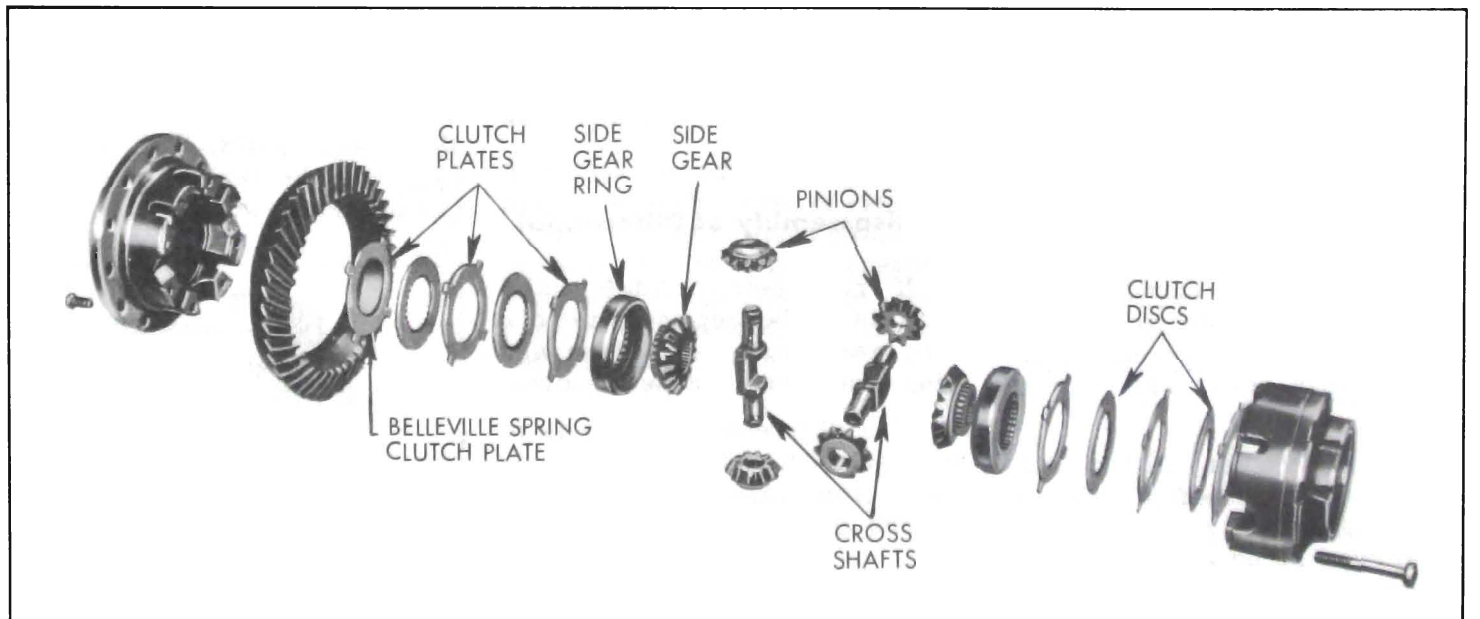

Figure 6-39—Positive Traction Differential - Exploded

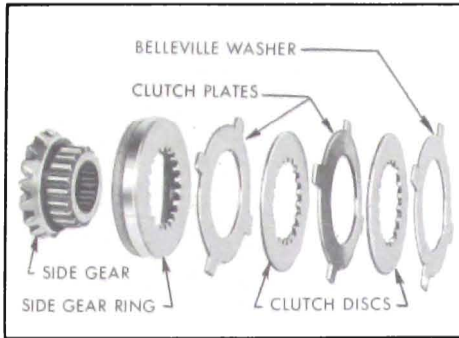

Figure 6-40—Clutch Pack

The outer plate of each clutch pack is a Belleville spring (dished) which takes up all clutch pack clearance and adds a slight pre-load. When turning a sharp corner under normal conditions, the differential action is essentially the same as that of a conventional differential.

CAUTION: When working on a car with a Positive Traction Differential, never raise one rear wheel and run the engine with the transmission in gear. The driving force to the wheel on the floor may cause the car to move.

6-10 LUBRICATION OF POSITIVE TRACTION DIFFERENTIAL

The lubricant level should be checked every 1000 miles. Maintain level between the bottom of the filler plug opening and 1/4 inch below the opening by adding Special Positive Traction lubricant available through the Buick Parts Department under Part No. 531536. Never use lubricant other than this special lubricant, even for adding, or a severe clutch chatter may result when turning corners.

Positive Traction Differentials can be easily identified either by a stainless steel plate around the filler plug or by an X in a circle stamped on the bottom edge of the carrier housing flange. See Figure 6-41. However, if the wrong lubricant is accidentally added, it

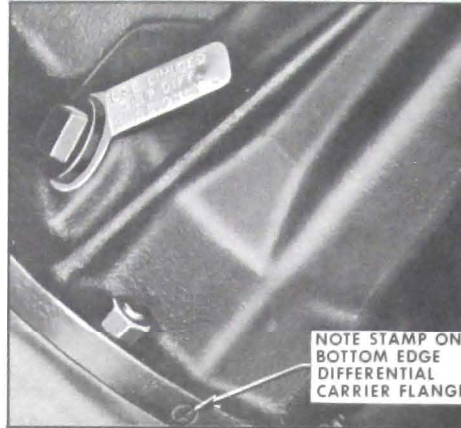

Figure 6-41—Identification of Positive Traction Differential Axle

will be necessary to completely remove all lubricant, flush with light engine oil, and then fill with the special lubricant. Capacity of the rear axle housing is 4-1/2 pints.

6-11 POSITIVE TRACTION DIFFERENTIAL SERVICE PROCEDURES

All rear axle service procedures are the same in the Positive Traction rear axle as in a conventional rear axle, except for servicing the internal parts of the differential assembly. All rear axle parts outside of the differential such as the ring gear, differential side bearings, and axle shafts are the same in either rear axle assembly.

a. Disassembly of Differential

1. If ring gear or differential case is to be replaced, remove ring gear from case. Otherwise ring gear need not be removed.
2. If a differential bearing is to be replaced, pull bearing outer race from case using Remover J-6552 as shown in Figure 6-14.
3. Clamp case assembly in a brass jawed vise by ring gear or by case flange.
4. Mark flange half and cover

half of case with a center punch to provide alignment when assembling. If cross shafts are to be reused, see that they have a paint daub on one end of each shaft matching a similar paint daub on the case to assure assembly in proper location. See Figure 6-42.

5. Loosen 8 bolts holding cover half to flange half. Remove assembly from vise, place on bench with bolt heads up and remove bolts.

6. Lift cover half of case from flange half. Remove cover half cross shaft, pinions, side gear, side gear ring, clutch plates and discs. Keep with cover so they can be reinstalled in their original positions.

7. Remove corresponding parts from flange half of case and keep with flange half.

b. Cleaning and Inspection of Parts

1. Make certain that all differential parts are absolutely clean and dry.
2. Inspect cross shafts, pinions and side gears. Replace any parts which are excessively scored, pitted or worn.
3. Inspect side gear rings and differential case halves for scoring. Replace damaged or excessively worn parts. Both halves of case must be replaced if one half is damaged or worn.

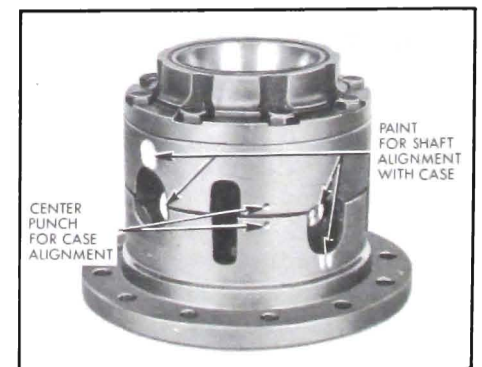

Figure 6-42—Alignment Marks

4. Inspect clutch discs and plates for worn, cracked or distorted condition. If any of these defects exist, new clutch packs must be installed.

c. Assembly of Differential

1. If ring gear was removed, install ring gear on case flange using three Studs J-6251 as shown in Figure 6-33.

2. If a differential bearing outer race was removed, drive new race into case using Replacer J-9742 as shown in Figure 6-32.

3. Place flange half of differential case on bench with opening up.

4. Oil clutch plates and discs thoroughly with Special Positive Traction Lubricant and install clutch packs. If inspection showed plates and discs to be in good condition, install original side gear ring and clutch pack on each side gear according to Figure 6-40. If any plates or discs were defective, install two new clutch packs.

5. Oil remaining parts with Special Lubricant just before installing. With clutch packs in place on both side gears, next install proper side gear and clutch pack in flange half of differential.

6. Install pinion gear and cross shafts as shown in Figure 6-44. Be certain bevelled sides of shafts match ramps in case. See Figure 6-43.

7. Install other side gear and clutch pack. Align clutch plate

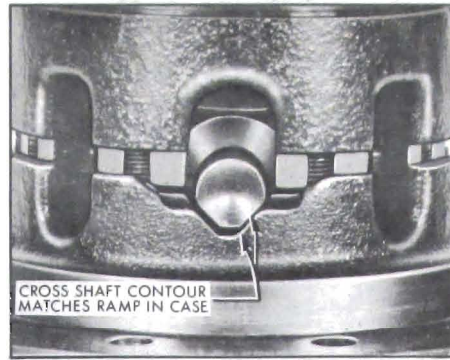

Figure 6-43—Matching Cross Shafts and Case Ramps

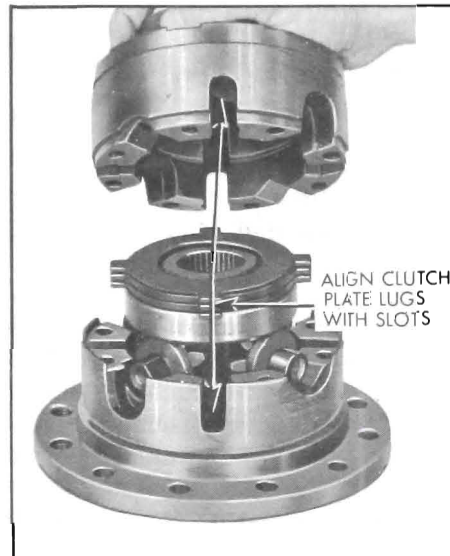

Figure 6-44—Installing Differential Parts

lugs with slots in differential case.

8. Check location of alignment marks on both halves of case and on cross shafts. Place cover half of case over clutch pack, engaging slots with clutch plate lugs. Make certain that paint daubs on shaft ends match daubs on case.

9. Install eight cover to flange half bolts and tighten evenly and alternately to 40 ft. lbs. torque. See Figure 6-45.

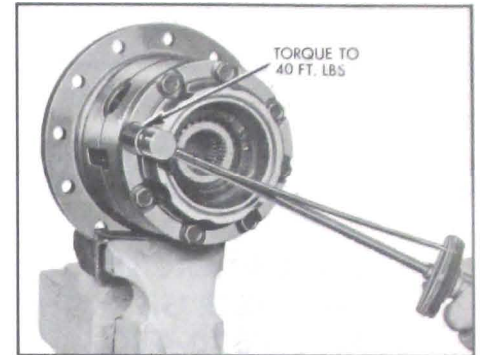

Figure 6-45—Torquing Differential Bolts

d. Simple Procedure for Testing a Positive Traction Differential

If there is a doubt that a Buick is equipped with a Positive Traction Differential, or to determine if this option is performing satisfactorily, a simple test can be performed.

Place a roller-equipped floor jack far outboard under the rear axle housing to slightly raise one wheel. This wheel should touch the floor merely to the extent that it can be turned by hand. With one person guiding the jack, another can attempt to slowly drive the car forward. If the car is equipped with a proper functioning Positive Traction Differential the car will move forward since the slipping wheel has just enough ground contact friction to engage the clutch pack.