

SECTION 3-F ROCHESTER 4-BARREL CARBURETOR

CONTENTS OF SECTION 3-F

Paragraph	Subject	Page	Paragraph	Subject	Page
3-18	Description and Operation of Rochester 4-Barrel Carburetor	3-41	3-20	Assembly and Internal Adjustment of Rochester 4-Barrel Carburetor	3-47
3-19	Disassembly, Cleaning, and Inspection of Rochester 4-Barrel Carburetor	3-46	3-21	External Adjustment of Rochester 4-Barrel Carburetor	3-50

3-18 DESCRIPTION AND OPERATION OF ROCHESTER 4-BARREL CARBURETOR

a. General Description

The Rochester Model 4GC is a 4-barrel down-draft type which provides the advantages of a compound installation of two 2-barrel carburetors in one compact unit. See Figure 3-41 or 42. To aid description and the proper identification of parts the carburetor is considered to be divided into a primary section and a secondary section.

The primary section covers the 2-barrelled forward half of the carburetor assembly. This section is essentially a complete 2-barrel carburetor containing a

float system, idle system with adjustable needle valves, main metering system, power system, and accelerating system. This section also includes the automatic choke mechanism.

The secondary section covers the 2-barrelled rearward half of the carburetor assembly. This section is essentially a supplementary 2-barrel carburetor which cuts in to assist the primary section when a predetermined throttle opening and engine RPM are reached. This section contains a float system, a non-adjustable idle system, and a main metering system. It has a separate set of throttle valves and a set of auxiliary valves, which are located in the barrels above the throttle valves.

The primary throttle valves are operated by the accelerator pedal

and the connecting throttle linkage. The secondary throttle valves are operated by the primary throttle valve shaft through delayed action linkage which permits a predetermined opening of the primary valves before the secondary valves start to open. Action of the linkage then causes both sets of throttle valves to reach the wide open position at the same time.

b. Operation of Float System

Each section of the carburetor has a separate and independent float system, consisting of a float chamber formed by a partition in the main body, a 2-pontoon float, a needle valve seat and valve. Fuel enters the carburetor through the inlet port in the primary side of the air horn. From this point fuel flows to the separate float chambers through a horizontal passage in the air horn. There is a fuel strainer located just above each needle seat on both the primary and secondary side. See Figure 3-43.

When the fuel reaches the prescribed level in each float chamber the float moves the needle valve against its seat to shut off the flow of fuel. The needle valves are connected to the float levers by clips. Because of these, the needle valves will be pulled from their seats if stickiness is encountered due to gum formation.

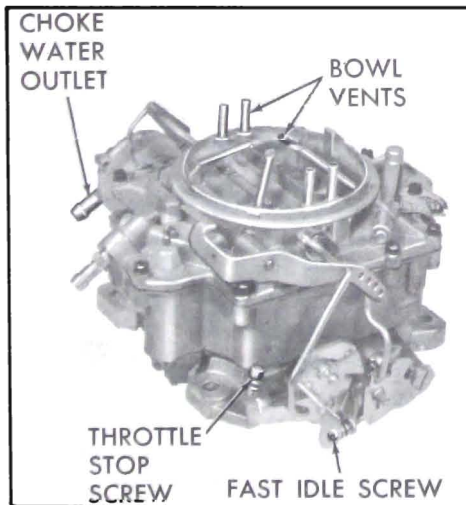

Figure 3-41—Rochester 4-Barrel Carburetor-300 Engine

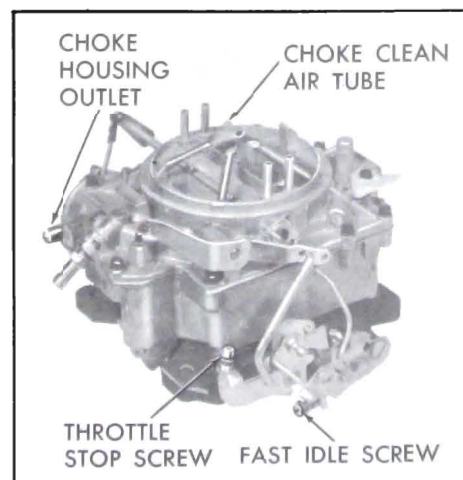

Figure 3-42—Rochester 4-Barrel Carburetor-401 Engine

The floats are spring loaded at the rear tangs. The purpose of these balance springs is to give a more positive closing of the needle valves. The spring tension against the tangs determines float drop and also helps determine fuel level. See Figure 3-43.

There is a cored passage located in the side of the carburetor body which links the fuel chambers on the primary and secondary sides together. In this way, any abnormal rise in fuel in one side of the carburetor bowl will automatically balance with the other side.

The joint between the air horn and the main body is sealed by a gasket, and the float chambers are vented by passages which are calibrated to provide proper air pressure above the fuel under all operating conditions. These passages in the air horn lead into the throat of the air horn, and to outside atmosphere. The amount of fuel metered by the carburetor depends on the air pressure on the fuel in the float bowl. The external vents permit fumes to escape from the float chambers when the engine is idling or stopped after extremely hot operation.

c. Operation of Idle (Low Speed) Systems

Each barrel of the carburetor has a separate idle system but the general operation is identical in all barrels. The idle system in each barrel supplies fuel to the engine whenever the position of the throttle valve is such that suction is created at the idle discharge holes in the throttle body.

Suction on an idle discharge hole causes fuel in the float chamber to flow through the main metering jet and upward into the idle tube which meters the fuel. Calibrated bleed holes permit air to enter at the top and side of the idle

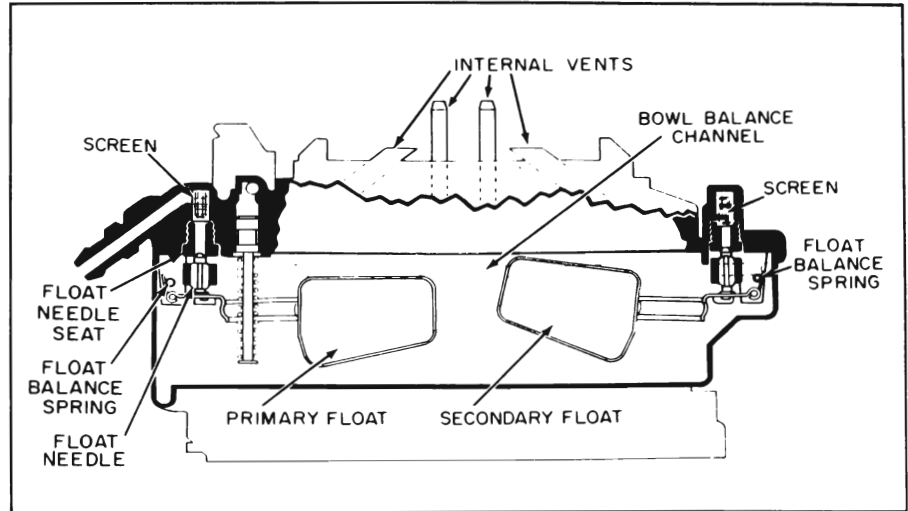

Figure 3-43—Primary and Secondary Float Systems

passage in the cluster so that a mixture of fuel and air passes down the idle channel to the idle discharge holes. Additional air is drawn into the fuel-air mixture in the idle channel through lower idle air bleeds which are in the primary side of the main body. See Figure 3-44.

When the throttle valve is closed, the fuel-air mixture is supplied through the lower idle discharge

holes only, since the upper holes are above the valve and are not affected by suction. As the throttle valve is opened, suction is also placed on the upper idle discharge holes which then feed additional fuel-air mixture into the engine. With continued opening of the throttle valve the suction on the idle discharge holes tapers off until a point is reached where the idle system no longer supplies fuel-air mixture. Before

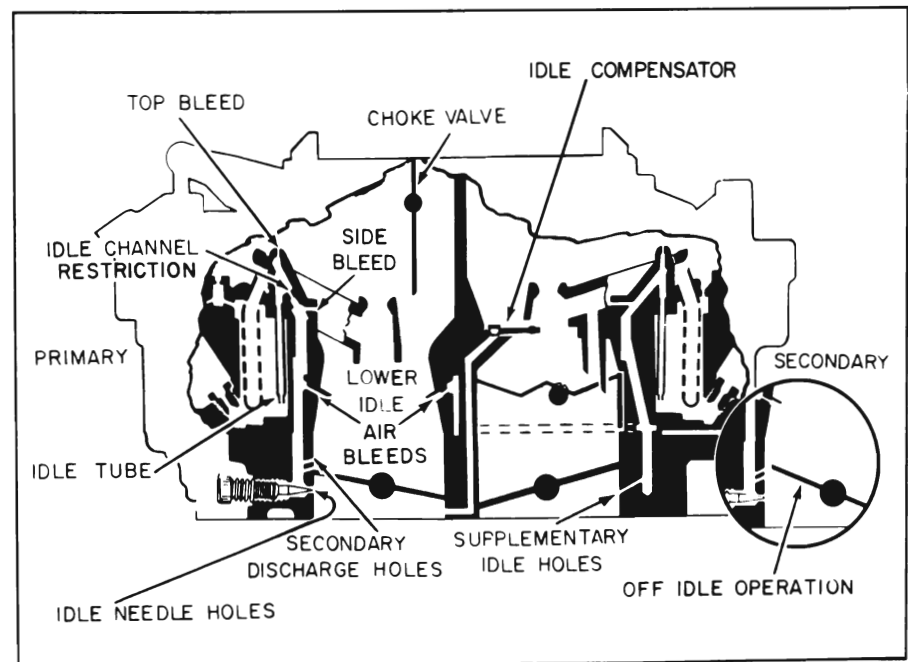

Figure 3-44—Primary and Secondary Idle Systems

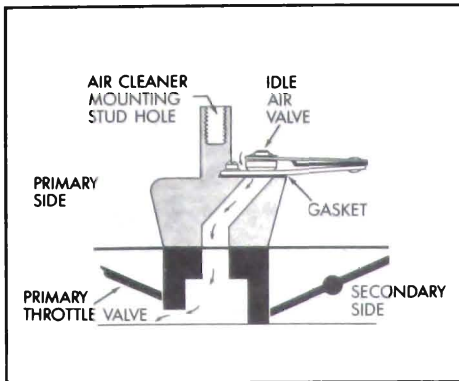

Figure 3-45—Idle Compensator

this point is reached however, the main metering system has begun to supply fuel, as described later.

The lower idle air bleeds discharge fuel after the idle systems cease to operate, thereby keeping fuel immediately available in the idle channels at a point very near the idle discharge holes and also enriching the mixture being delivered by the main metering system.

In the primary section, the quantity of fuel-air mixture supplied through the lower idle discharge holes is controlled by the idle needles, which may be adjusted to provide smooth engine idle operation. In the secondary section, the quantity of idle fuel-air mixture is controlled by the fixed size of discharge holes located in the rear of the secondary throttle bores.

On the secondary side of the float bowl, a thermostatic valve allows additional air to enter the primary bores under extreme hot idle conditions. This valve, called the "idle compensator", is operated by a bi-metal strip which senses temperature. See Figure 3-45. In a prolonged hot idle the bi-metal strip bends, raising the valve and uncovering a hole leading to the underside of the primary throttle valves. The additional air drawn into the engine in this manner is sufficient to offset the enriching effects of high temperatures and prevent hot idle stalling. When underhood

temperatures are lowered, the valve closes and operation returns to normal. This valve cannot be repaired, so a defective valve must be replaced.

d. Operation of Main Metering Systems

Each barrel of the carburetor has a separate main metering system; however, the operation of all systems is identical. The main metering system in each barrel supplies fuel to the engine whenever the position of the throttle valve is such that the incoming air stream creates suction on the main discharge nozzle.

Air entering the barrel through the air horn passes through the venturi tubes which increases the velocity of the air and create a suction on the main discharge nozzle. This causes fuel to flow from the float chamber through the main metering jet into the main discharge nozzle. Air is drawn in through the high speed bleeder so that a mixture of fuel and air is discharged from the main discharge nozzle into the air stream passing through the small venturi in the barrel of the carburetor. See Figure 3-46.

The main metering systems in the primary section control the flow of fuel during the intermediate or part throttle range of operation and up to approximately 85 MPH if the car is accelerated gradually. The secondary throttle valves remain closed until the primary valves have opened approximately 45-55 degrees, after which they are opened proportionately so that all valves reach the wide open position at the same time. While the secondary throttle valves are closed, the auxiliary valves located above them are held closed by the spring tension on the auxiliary valve shaft; therefore, there is not sufficient air flow through the barrels to

operate the main metering system in the secondary section.

When the secondary throttle valves are open and engine speed is about 1600 RPM, the resulting air flow through the secondary barrels starts to open the auxiliary valves because their supporting shaft is located off-center in the barrels. The auxiliary valves will be fully open at approximately 2800 RPM. When the auxiliary valves are open the main metering systems in the secondary section also supply fuel to the engine. See Figure 3-46.

During the period in which the secondary throttle valves are open and air flow is not high enough in the secondary bores to open the auxiliary valves, additional fuel is needed for the air which by-passes around the auxiliary valves. This additional fuel is supplied by tubes which extend from the mixture channel in the venturi cluster arm to the low pressure point below the closed auxiliary valves. The tubes are slanted on the bottom to provide a smoother transition between the opening of the secondary valves and the opening of the auxiliary valves. When the air flow is high enough to open the auxiliary valves, the down tubes no longer feed the fuel because the low pressure point is now in the small venturi. With this feature the correct fuel-air mixture is supplied at any point during secondary throttle valve operation.

e. Operation of Power System

For maximum power under load or for all speeds above approximately 85 MPH, a richer mixture is required than that necessary for normal throttle opening. This additional fuel is provided by one power system connected to the main metering systems in the primary section of the carburetor. See Figure 3-46.

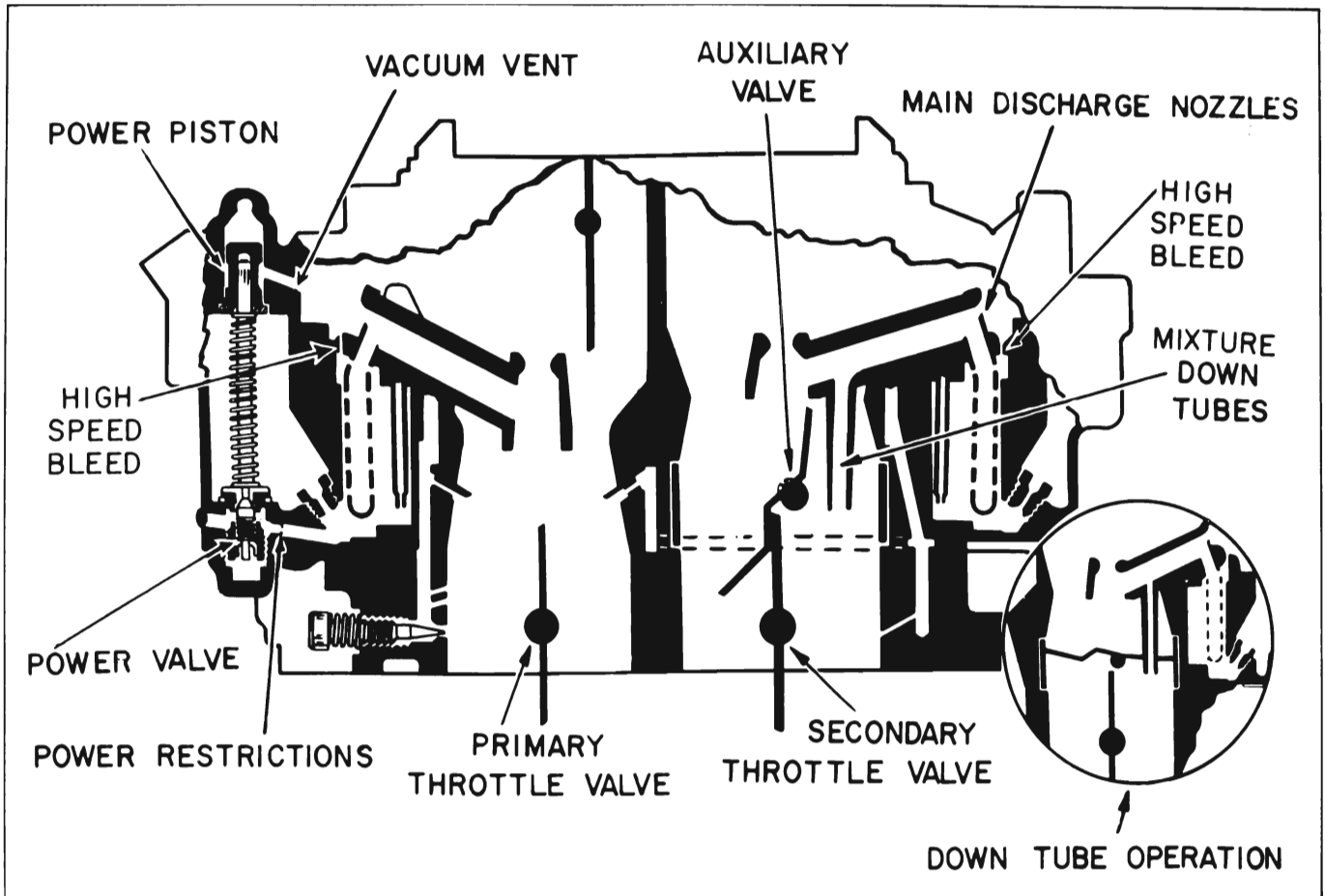

Figure 3-46—Main Metering and Power Systems

The power piston cylinder in the air horn of the carburetor is connected by a channel to the face of the mounting flange so it is subject to intake manifold vacuum. At part throttle position the vacuum is sufficient to hold the power piston in its "up" position against the tension of the piston spring. When the throttle valves are opened to a point where manifold vacuum drops to approximately 9 to 5 inches of mercury and additional fuel is required for satisfactory operation, the piston spring moves the power piston down to open the power valve. This allows additional fuel to enter the main discharge nozzles in the primary section through calibrated restrictions located below the main metering jets. See Figure 3-46.

f. Operation of Accelerating System

For smooth and rapid acceleration it is necessary to supply an extra quantity of fuel momentarily when the throttle is opened suddenly. This is accomplished by one accelerating pump piston which is directly connected to the primary throttle shaft lever by means of a rod and pump lever.

When the throttle is closed, the pump piston moves up and draws a supply of fuel from the float chamber through the inlet strainer, past the inlet ball check valve and into the pump cylinder. When the throttle is opened, the piston on its downward stroke exerts pressure on the fuel which closes the inlet check ball and opens

the outlet check ball. A metered quantity of fuel is then discharged through the pump discharge nozzles into each barrel in the primary section of the carburetor. This occurs only momentarily during the accelerating period. The pump duration spring which

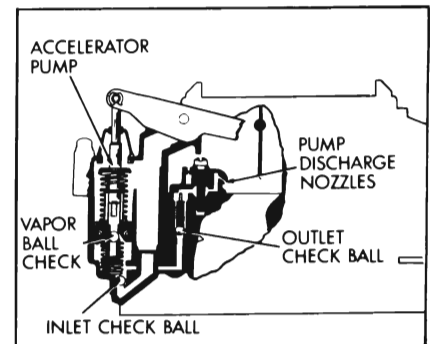

Figure 3-47—Accelerating System

is compressed by the downward movement of the pump linkage against the resistance of the fuel provides a follow-up action so that the discharge carries out over a brief period of time. A ball check in the accelerator pump plunger acts as a vapor vent to prevent vapor pressure from forcing fuel from the pump discharge holes during extreme heat periods. Downward movement of the plunger, however, seats the ball and allows normal operation of the accelerating system. See Figure 3-47.

When the desired speed is reached and the throttle is held in a fixed position, the pressure on the fuel decreases sufficiently so that the outlet check ball closes and fuel ceases to discharge from pump nozzles. Thus a quantity of fuel is maintained in the channel adjacent to the outlet check ball where it is immediately available for future requirements.

g. Operation of Choke System

In 401 and 425 engines, the automatic choke mechanism is contained in the primary section of

the carburetor. It consists of a choke valve mounted on a shaft in the carburetor air horn connected through linkage to a thermostat mounted on the carburetor throttle body. The thermostat contains a bi-metal spring and a vacuum actuated piston. A choke rod connects the choke valve to a fast idle cam on the throttle body. A heat pipe connects the choke housing to a heat stove in the right exhaust manifold.

The heat stove in the exhaust manifold heats the air which is drawn through it and the heat pipe into the choke housing. A restriction in the choke housing cover regulates the quantity of air flowing into the choke housing to heat the thermostat.

When the accelerator pedal is depressed preparatory to starting the engine, the throttle stop screw is lifted clear of the fast idle cam and the thermostat then closes the choke valve. When the engine starts, intake manifold vacuum causes the piston to partially open the choke valve against the spring tension of the thermostat, thereby admitting sufficient air to give a satisfactory running mixture.

If the throttle is partially opened while the running engine is cold, the increased force of air flow against the off-set choke valve will open the valve against the spring tension of the thermostat. At the same time the choke valve opens, the fast idle cam will also drop to a new position, thereby reducing the fast idle speed when the throttle is again closed.

As the engine and exhaust manifold warm up, warm air is drawn through the heat pipe into the choke housing by manifold vacuum. This warms the thermostat, causing it to reduce its spring tension on the choke valve in proportion to the increase in temperature. This, in turn, allows the choke valve to be opened by the combined forces of air velocity on the valve and vacuum on the choke piston.

When the engine reaches normal operating temperature, the choke thermostat is heated to the point where it no longer exerts any spring tension on the choke valve. The choke valve is in the wide open position and the fast idle cam is in the slow idle position so that the fast idle screw misses

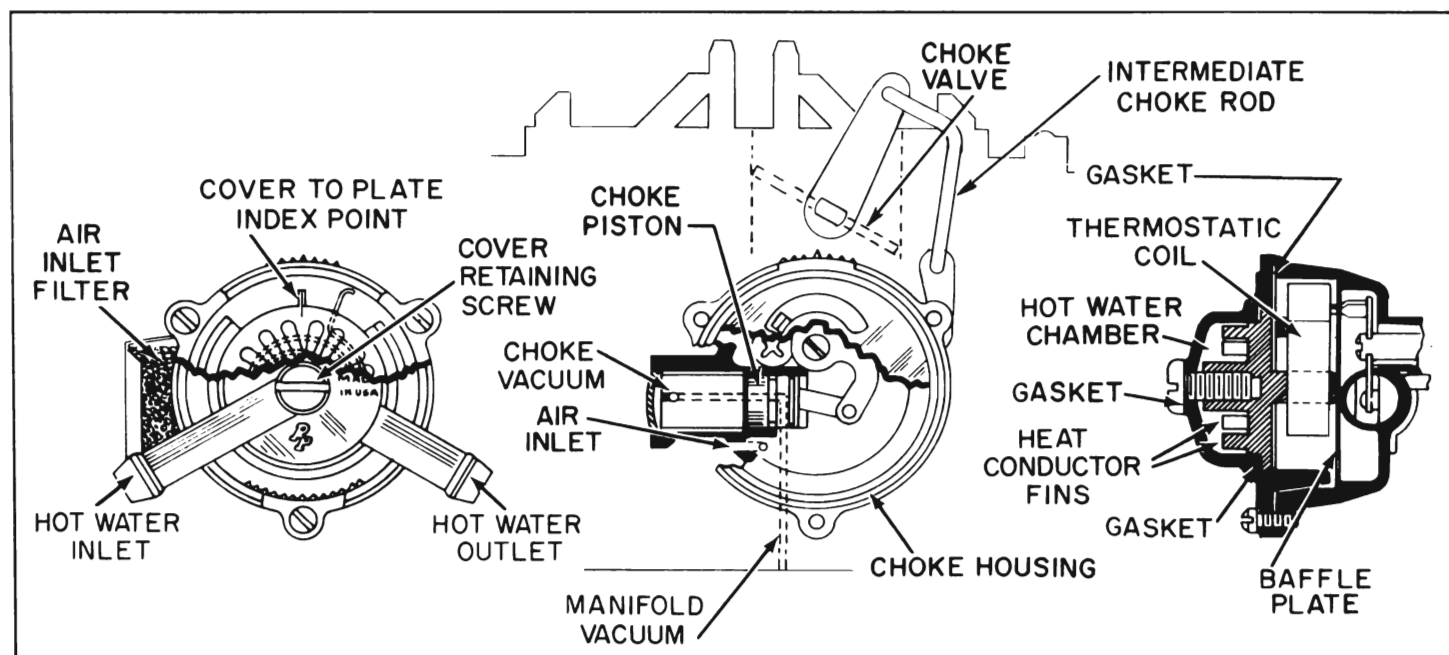

Figure 3-48—Water Heated Choke Housing-300 Engine

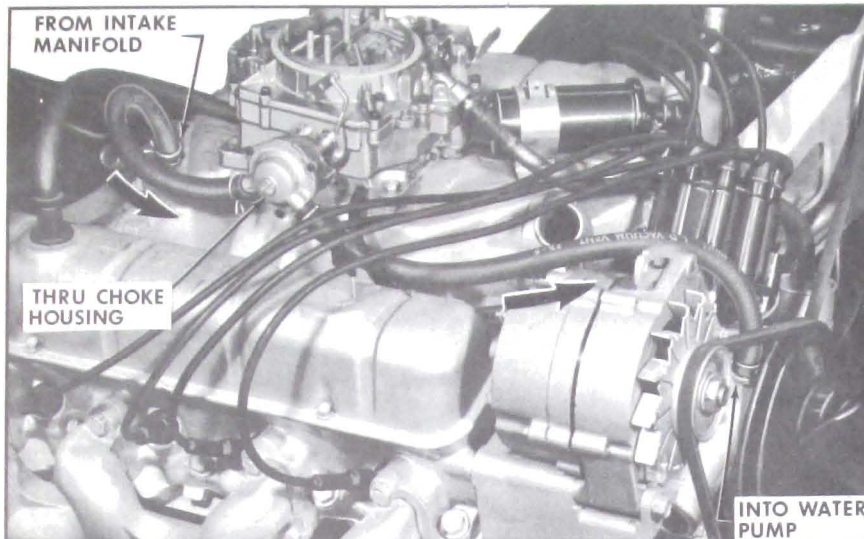

Figure 3-49—Water Heated Choke System-300 Engine

the cam completely. The throttle stop screw now takes over in determining curb idle speed.

In 300 engines, a hot water heated choke system is used. Instead of using hot air from the exhaust manifold to heat the choke thermostatic coil, heat from the engine hot water is used. The engine water is circulated directly from the engine to a chamber in the choke cover. Heat is transmitted to the thermostatic coil inside the choke housing by fins which project from the inner choke cover into the hot water circulating through the choke cover. See Figures 3-48 and 49.

Automatic choke failure due to build up of dust or other foreign material in the choke housing is prevented by a filter located at the side of the choke housing assembly. All air entering the choke housing, due to manifold vacuum drawing air into the choke housing, is filtered. Periodic service of the filter element is required to keep the air inlet open and free of foreign material.

h. Operation of Choke Unloader

If the engine becomes flooded for any reason, the choke valve can

be partially opened by depressing the accelerator pedal to the full extent of its travel. This causes an arm on the throttle lever to contact and rotate the fast idle cam, which forces the choke valve open.

i. Operation of Secondary Lock-Out

The secondary section does not have a choke valve in the air horn. In order to prevent air from entering the carburetor through the secondary side during the engine warm-up period it is necessary to block the movement of the secondary throttle valves by means of the lock-out slot in the fast idle cam.

When the choke valve is in any position except wide open, it holds the fast idle cam up from its lowest position. This causes a lock-out slot in the fast idle cam to engage a tang on the secondary throttle shaft lever which prevents the secondary throttle valves from opening.

When the choke is wide open the lock-out slot of the fast idle cam drops to its lowest position; the secondary throttle shaft tang is then free to move and the secondary valves can open.

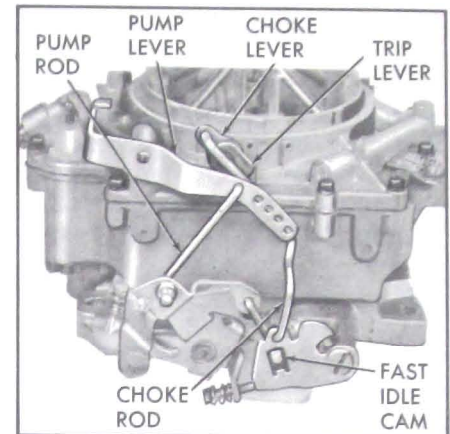

Figure 3-50—Exterior Linkage-300 Engine

3-19 DISASSEMBLY, CLEANING, AND INSPECTION OF ROCHESTER 4-BARREL CARBURETOR

1. Remove spring clip from upper end of intermediate choke rod and disengage rod from choke shaft lever. See Figure 3-50.
2. Remove clip from upper end of pump rod and disengage rod from pump lever. Remove horseshoe clip from upper end of pump plunger.
3. Remove choke trip lever and attaching screw. Disengage choke lever and collar assembly from choke shaft and disengage lower end of choke rod from fast idle cam. Then remove choke lever and collar, and choke rod as an assembly. See Figure 3-50.

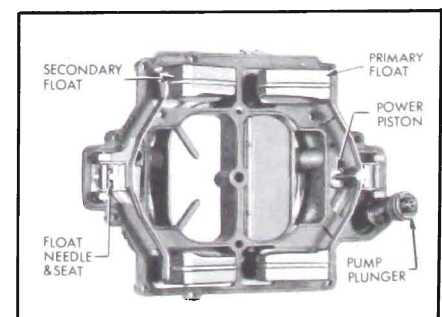

Figure 3-51—Air Horn Parts

4. Remove two choke valve attaching screws. Remove choke valve from slot in shaft. Remove burrs from choke shaft, then remove shaft from air horn.

5. Remove all air horn screws, then carefully lift air horn straight up from main body to avoid damaging floats, pump plunger, and vacuum power piston which are attached to air horn. See Figure 3-51.

6. Remove float hinge pin, float and needle from primary side being careful not to damage small spring. Then remove inlet needle seat and gasket. Remove fuel inlet strainer. NOTE: Keep primary float system parts separate from secondary float system parts.

7. Remove float hinge pin, float needle, needle seat, and gasket from side opposite pump (secondary). Then remove needle seat strainer. See Figure 3-51.

8. Remove pump plunger assembly and boot from air horn. Remove air horn gasket.

9. Remove power piston assembly by compressing spring and letting it snap repeatedly until hammering action of power piston drives staked retaining disk from air horn. NOTE: It may be necessary to remove burrs if heavy staking is encountered.

10. Remove thermostat cover screws and retainers. Remove thermostat cover assembly and gasket. Remove choke baffle plate. Remove choke piston lever screw and take choke piston, piston pin, connecting link, and lever from thermostat housing as an assembly.

11. In a 300 engine carburetor, remove three choke cover attaching screws and retainers. Remove choke cover assembly, gasket and insulator baffle inside choke housing. The outer water jacket

cover may be disassembled from inner choke cover by removing large screw and metal gasket in center of cover; then remove outer water jacket cover and gasket between inner and outer cover.

NOTE: The large inner to outer choke cover screw should never be loosened unless all coolant is drained from the choke housing. A loose screw could allow coolant to leak into the choke housing and on into the engine.

The air inlet filter on the side of the choke housing can be removed by snapping off spring retaining clip.

12. Remove screws holding thermostat housing to throttle body. Remove thermostat housing and gasket. Then remove intermediate choke shaft, lever, and rod from choke housing as an assembly.

13. Remove attaching screws from cluster assembly on pump side of carburetor (primary). Then carefully remove cluster assembly and gasket. NOTE: Keep primary main body parts separate from secondary main body parts as they are all different.

14. Remove both main metering jets from pump side of main body. See Figure 3-52. Remove power valve and gasket.

15. Remove pump return spring from pump plunger well. Remove outlet check ball spring guide from outlet hole. Carefully invert carburetor main body and catch aluminum pump inlet check ball and larger steel pump outlet ball in hand.

16. If necessary, remove pump inlet screen and retainer from bottom of float bowl. NOTE: If screen is not visibly damaged or plugged, it need not be removed.

17. Remove secondary cluster assembly screws, cluster assembly, and gasket. Remove both secondary main metering jets.

18. Remove idle compensator and gasket from secondary side by removing two self-tapping screws.

Be careful not to bend or distort valve holder strip or bi-metal strip.

19. Invert carburetor. Remove idle mixture adjusting needles and springs. Remove vacuum hose fitting.

20. Remove throttle body to main body screws. Asbestos plug and retainer must be removed to gain access to one screw. Remove throttle body and gasket.

21. Remove auxiliary throttle body assembly by lifting straight up from inverted bowl. CAUTION: This auxiliary throttle assembly should not be disassembled because it is calibrated at the factory.

22. The throttle body assembly consisting of the body, primary and secondary throttle valves, shafts, levers, and springs is serviced only by replacing the assembly. Therefore the throttle body should not be disassembled further for normal cleaning and inspection.

3-20 ASSEMBLY AND INTERNAL ADJUSTMENT OF ROCHESTER 4-BARREL CARBURETOR

When assembling the carburetor, use all new gaskets and any additional new parts found to be necessary during inspection. Calibrated parts must be as specified for carburetor CODE number.

1. With main body inverted on bench, place auxiliary throttle body assembly in its proper position with screw heads toward top of carburetor. Check to make sure it is flush or slightly below main body casting.

2. Place new gasket on main body and install throttle body assembly and screws.

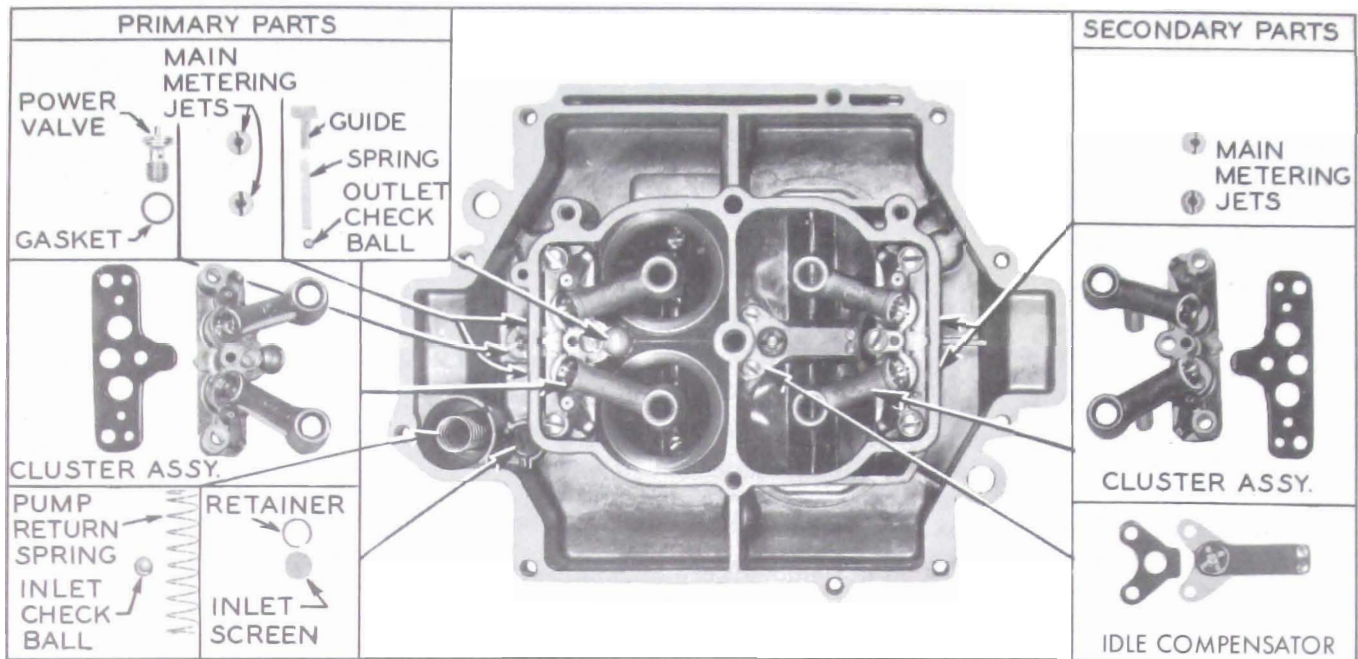

Figure 3-52—Main Body Parts

3. If removed, install throttle stop screw and fast idle screw with springs (throttle stop screw has a round point; fast idle screw has a flat point). Install vacuum hose fitting. Install both idle mixture needles and their springs. Seat needles lightly and back out 1-1/2 turns which will provide an average starting adjustment. Forcing needles hard against seats will score them and ruin them for service.

4. Place throttle body and main body assembly in upright position on bench or mounting fixture.

5. Install idle compensator using a new gasket. Install secondary cluster assembly using a new gasket. This cluster has no pump discharge nozzles.

6. Install all four main metering jets. These jets have tapered seats and do not require gaskets.

NOTE: The primary jets are the two having the smaller holes and are installed in the pump side of the body.

7. Install pump outlet check ball. This is a steel ball and is larger

than the pump inlet ball. Install pump outlet ball spring and spring guide.

8. Install primary cluster assembly, screws, lock washers, and new gasket in pump side of carburetor.

9. Install new pump inlet screen and retainer if old screen was removed.

10. Install pump inlet check ball (small aluminum) and pump return spring. NOTE: Never substitute a steel ball for the aluminum ball.

11. Install power valve and gasket.

12. Assemble choke piston and pin to choke piston lever and connecting link, make sure that pin hole in piston is opposite from tang on lever. Then install in thermostat housing. Install intermediate choke shaft, lever, and rod assembly in choke housing with lever hanging down. Connect choke piston lever to intermediate choke shaft with screw. Do not use lubricant of any kind on piston or in cylinder.

13. Install thermostat housing on throttle body using a new gasket.

14. Install pump plunger assembly and boot in inverted air horn. Install power piston assembly and stake securely in air horn. Power piston must be free in any position.

15. Install new air horn gasket. Install a fuel inlet strainer on inlet side of each needle seat. Install float needle seats and gaskets. Install float needles, floats, and hinge pins making sure that float tangs are placed outside balance springs. NOTE: All primary and secondary float system parts should go back in their same positions, thereby holding need for float adjustments to a minimum. The float needles are also matched to their respective seats and should never be mixed.

16. Adjust Primary Float Level. Make all float adjustments with gasket in place.

(a) With air horn inverted, position part of primary gauge marked "HEEL" vertically at highest

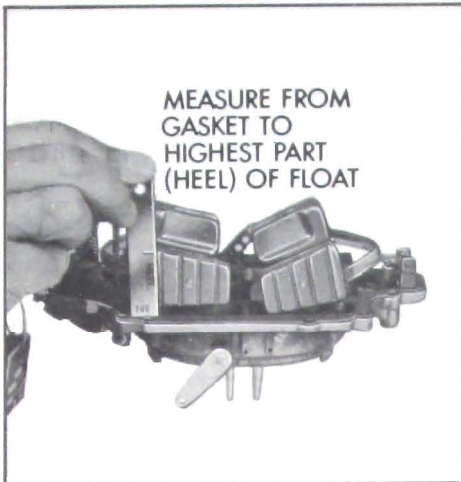

Figure 3-53—Primary Float Heel Adjustment

part of each float pontoon. See Figure 3-53. Adjust as necessary.

(b) Position part of primary gauge marked "TOE" vertically at dimple in each pontoon as shown in Figure 3-55. Adjust as necessary.

17. Adjust Secondary Float Level.

(a) With air horn inverted, position part of secondary gauge marked "HEEL" vertically at highest part of each float pontoon. See Figure 3-54. Adjust as necessary.

(b) Position part of secondary gauge marked "TOE" vertically at dimple in each pontoon. See Figure 3-55. Adjust as necessary.

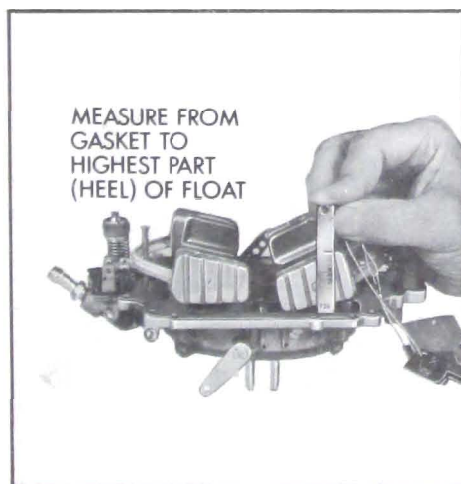

Figure 3-54—Secondary Float Heel Adjustment

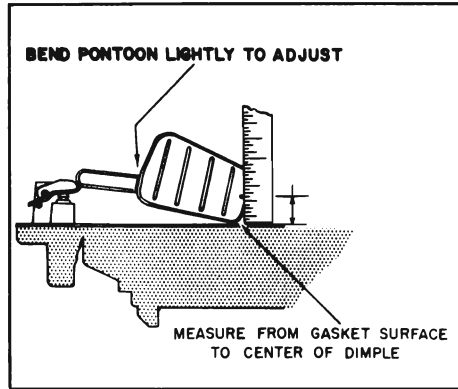

Figure 3-55—Secondary Float Toe Adjustment

18. Align Floats. Align bowl cover gasket with screw holes in cover. Then make sure all float pontoons are centered in and aligned with the gasket cut-outs. See Figure 3-56.

19. Adjust Float Drop. Float drop must be adjusted accurately because it affects float balance spring tension which, in turn, affects fuel level in the bowl.

(a) Hold air horn upright and level, gasket in place and floats hanging freely. Bounce floats lightly to make sure they are in normal settled position.

(b) Position part of primary gauge marked "DROP" vertically from air horn gasket to dimple in each primary pontoon. See Figure 3-57.

(c) Position part of secondary gauge marked "DROP" vertically from air horn gasket to dimple in each secondary pontoon. See Figure 3-58.

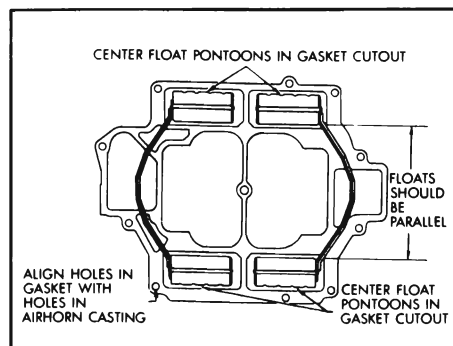

Figure 3-56—Float Alignment

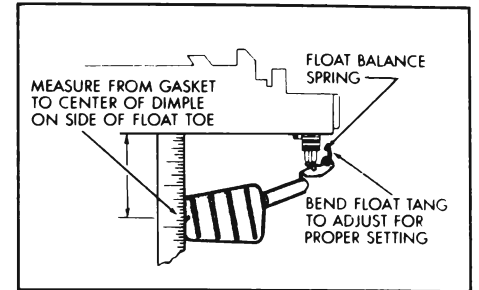

Figure 3-57—Primary Float Drop Adjustment

(d) If adjustment is necessary, bend float arm tang toward balance spring to decrease float drop, or away from balance spring to increase float drop.

20. If any float setting is changed, always recheck all other adjustments and alignment of that float.

21. Install air horn assembly on main body, using care to avoid distortion of float assemblies and making certain that pump piston cup does not have any creases or curled edges when it is inserted in cylinder. Install 13 air horn screws. Tighten three inner screws first for better sealing.

22. Install choke shaft and lever. Install choke valve with "RP" up and install screws loosely. Align choke valve by working choke shaft endwise while maintaining an upward pressure on choke shaft lever. Tighten and stake choke valve screws. Check for uniform clearance and freedom from sticking, as improper fit or binding may cause hard starting.

23. Install choke rod, and choke lever and collar assembly. Install

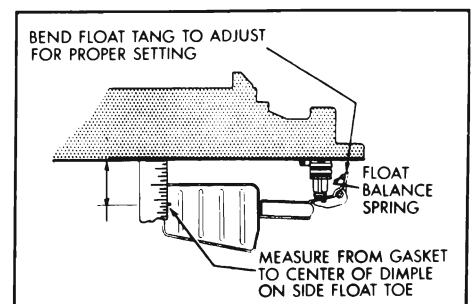

Figure 3-58—Secondary Float Drop Adjustment

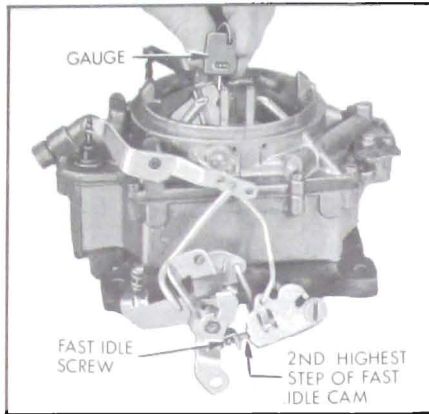

Figure 3-59—Checking Fast Idle Cam Adjustment

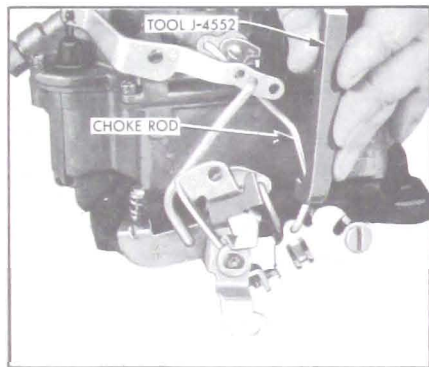

Figure 3-60—Adjusting Fast Idle Cam choke trip lever on end of choke shaft with “RP” out and tighten attaching screw. See Figure 3-50.

3-21 EXTERNAL ADJUSTMENT OF ROCHESTER 4-BARREL CARBURETOR

1. Fast Idle Cam Adjustment. Close throttle so that fast idle screw contacts second highest step of fast idle cam with side of screw against rise to high step of cam, then check clearance between choke valve and air horn dividing wall using .050" gauge (300 engine) or .030" gauge (401 engine). See Figure 3-59.

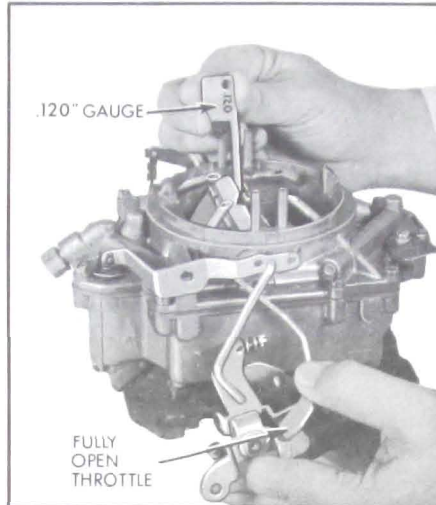

Figure 3-61—Checking Choke Unloader Adjustment

2. If choke valve clearance is not correct, bend choke rod as required to obtain this clearance using Tool J-4552. See Figure 3-60.

3. Choke Unloader Adjustment. Fully open throttle so that throttle arm contacts unloader tang on fast idle cam, then check clearance between choke valve and air horn dividing wall using .120" gauge. See Figure 3-50.

4. If choke valve clearance is not correct, bend unloader tang as required to obtain specified clearance using Tool J-5197. See Figure 3-62.

5. Secondary Lock-Out Adjustment. Close choke valve so that secondary throttle lock-out tang

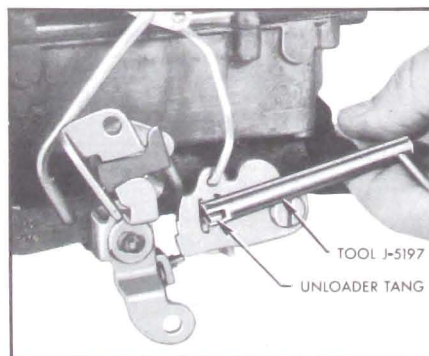

Figure 3-62—Adjusting Choke Unloader

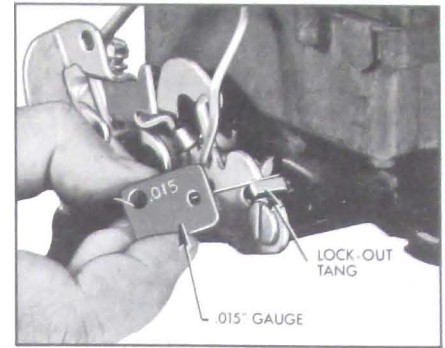

Figure 3-63—Checking Secondary Lock-Out Adjustment

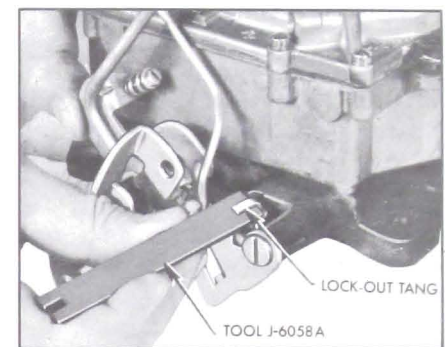

Figure 3-64—Adjusting Secondary Lock-Out

is on lock-out step of fast idle cam. Check clearance between tang and step using .015" gauge. See Figure 3-63.

6. If clearance between tang and lock-out step is not correct, bend tang as required to obtain this clearance using Tool J-6058A. See Figure 3-64.

7. Secondary Contour Adjustment. Fully open choke valve so that

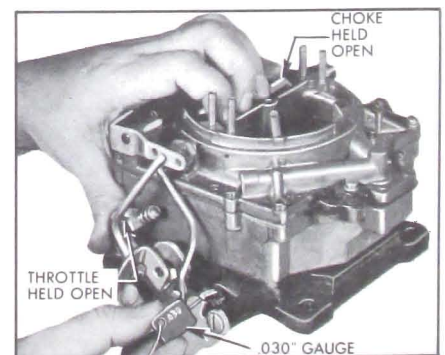

Figure 3-65—Checking Secondary Contour Adjustment

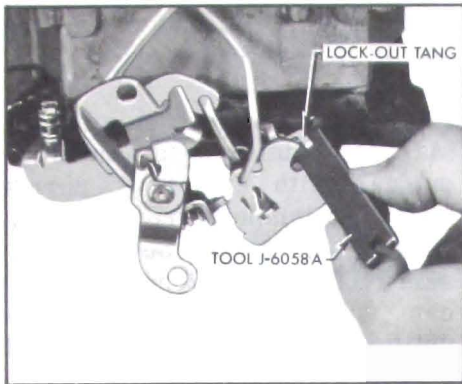

Figure 3-66—Adjusting Secondary Contour

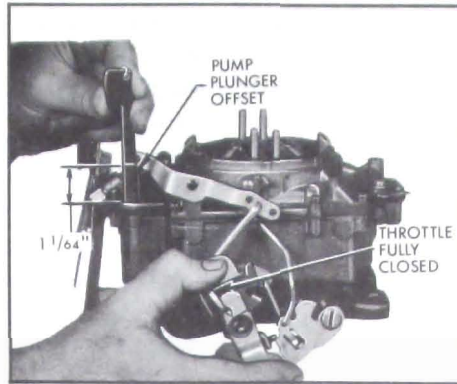

Figure 3-67—Checking Pump Plunger Adjustment

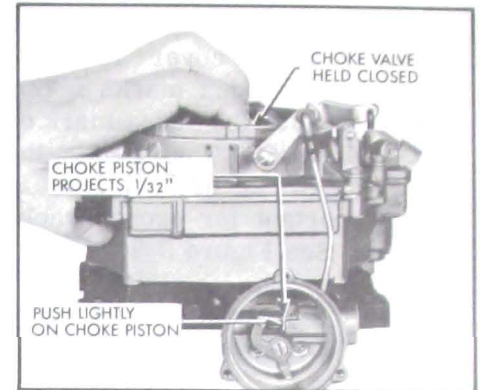

Figure 3-68—Checking Choke Piston Adjustment

fast idle cam falls to its lowest position. Then open throttle so that secondary lock-out tang follows contour portion of fast idle cam. With choke held wide open, check clearance between lock-out tang and contour portion of cam using .030" gauge. See Figure 3-65.

8. If clearance between tang and contour is not correct, bend tang as required to obtain this clearance using Tool J-6058A. See Figure 3-66.

9. If adjustment was necessary to correct lock-out tang to contour clearance, the tang to lock-out slot clearance should be rechecked (Steps 5 & 6) to be sure it was not disturbed.

10. Pump Plunger Adjustment. Push fast idle cam to full down position and back out throttle stop screw until primary throttle valves can be fully closed. With throttle held closed and pump rod in center hole of lever, measure vertically from under side of pump plunger offset to air horn casting. See Figure 3-67. Measurement should be 1-1/64" on 401 engine carburetors or 7/8" in the center (No. 3) hole on 300 engine carburetors. After adjusting, pump rod must be moved to the inner (No. 1) hole on synchromesh transmission cars.

11. Turn throttle stop screw in (from fully closed throttle position) one turn which will provide

an initial slow idle speed adjustment. Install intermediate choke rod and spring clip.

12. Choke Piston Adjustment. With choke valve held tightly closed, and with choke piston pushed lightly toward its cylinder (to take up any linkage slack), check to see that choke piston is projecting from cylinder 1/32". See Figure 3-68. If adjustment is required, bend intermediate choke rod using Tool J-5197. See Figure 3-69.

13. Choke mechanism must be absolutely free in any position; mechanism is free if choke will fall open from its own weight. Install choke baffle plate. Install choke cover and gasket. Rotate counterclockwise until index marks align and choke valve is

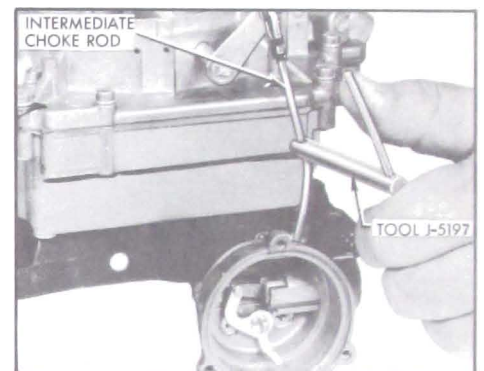

Figure 3-69—Adjusting Choke Piston just closed, then tighten screws and retainers. See paragraph 3-8.

14. Assembly of Hot Water Choke.

a. Assemble inner choke cover to outer cover by first placing a new gasket on the flat surface on outer cover. Then, install inner cover to outer cover, using large retaining screw and gasket.

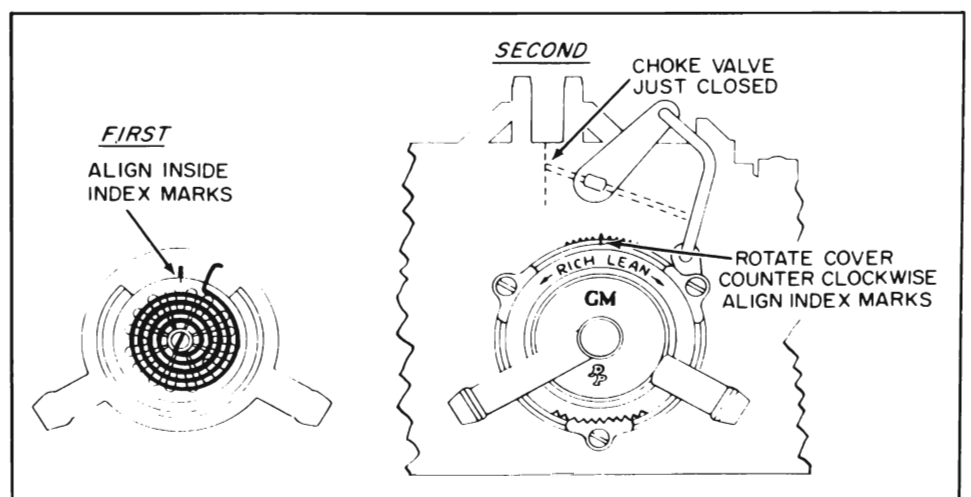

Figure 3-70—Choke Coil Adjustment-300 Engine

b. Before tightening the large outer to inner cover retaining screw, align index marks inside inner cover to the index mark on the outer cover. Then tighten the large screw securely. This is very important for proper choke indexing. See Figure 3-70.

c. Install new gasket on hot water choke cover assembly; then in-

stall assembly to choke housing rotating counterclockwise until the thermostatic coil picks up the choke piston lever and closes the choke valve. Rotate cover until index mark on cover aligns with the index mark on choke housing.

d. Install three choke cover retaining screws and retainers and tighten securely. With the index

markings aligned, the choke valve should be lightly closed at 75° F.

15. Fast Idle Speed Adjustment. Make fast idle speed adjustment on car with engine at normal operating temperature and transmission in drive. Set fast idle screw on lowest step of fast idle cam and adjust fast idle screw until engine speed is 600 RPM.