

SECTION 10-H

INSTRUMENTS AND CLOCK

CONTENTS OF SECTION 10-H

| Paragraph | Subject | Page | Paragraph | Subject | Page |
|-----------|---|-------|-----------|---|-------|
| 10-48 | Instrument Cluster Assembly, Generator, Oil Pressure and Temperature Indicators | 10-62 | 10-50 | Gasoline Gauge System - Description and Operation | 10-68 |
| 10-49 | Electric Clock | 10-68 | 10-51 | Gasoline Gauge-Trouble Diagnosis . | 10-69 |
| | | | 10-52 | Speedometer | 10-70 |
| | | | 10-53 | Accessory Switches on Control Panel | 10-73 |

10-48 INSTRUMENT CLUSTER ASSEMBLY, GENERATOR, OIL PRESSURE, AND TEMPERATURE, INDICATORS

CAUTION: Disconnect battery ground strap before removing any instrument panel unit or wiring.

a. Description of Instrument Cluster Assembly

The instrument cluster assembly shown in Figure 10-65 or 67 contains the speedometer, fuel gauge, indicator lights and clock. For the instrument cluster location in the instrument panel, see Figure 10-66 or 68.

A printed circuit is used to complete the circuits for all the lights and instruments in the cluster assembly. See Figure 10-69. A disconnect plug which is part of the instrument panel wiring harness attaches to the printed circuit connector pins. A key way is located in the printed circuit to insure correct assembly of the disconnect plug on the connector pins. If the printed circuit should become defective, it should be replaced as it is not practical to repair it.

b. Removal and Installation of Instrument Cluster Assembly

The complete instrument cluster seldom needs to be removed unless the printed circuit is defective. The speedometer, clock or

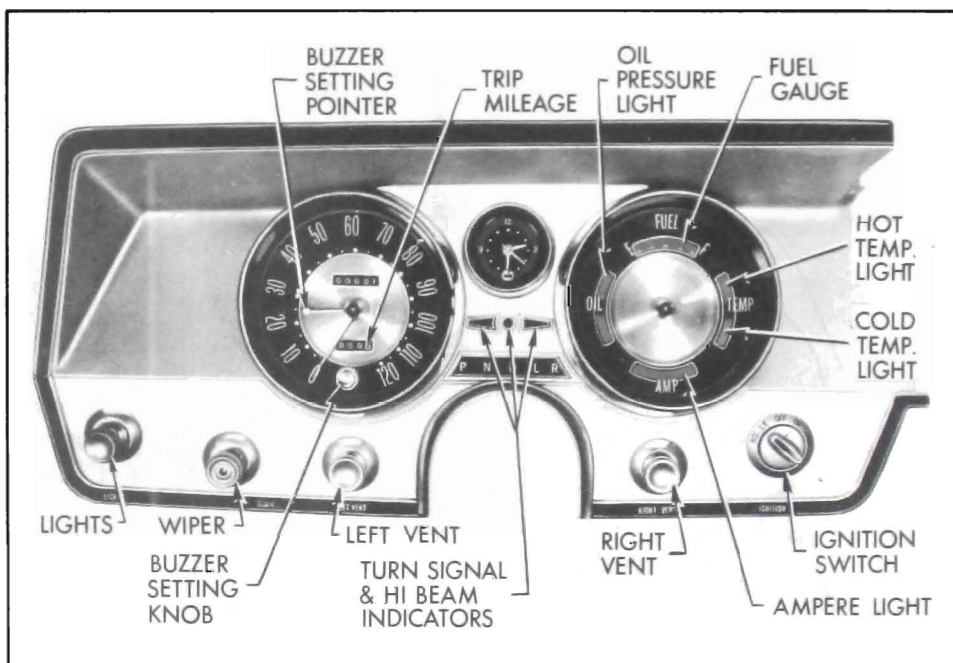

Figure 10-65—Instrument Cluster

gas gauge can each be removed without disturbing the instrument cluster housing. However, when the cluster assembly must be removed, proceed as follows:

1. Remove control panel and trim plate from center of instrument panel (since these overlap the right edge of the cluster housing).
2. Remove right and left lower access doors.
3. Disconnect wiring from light switch, wiper switch, ignition switch, ignition switch light, clock, clock light, multiple cluster connector and parking brake warning light. See Figures 141 thru 143.

4. Disconnect speedometer cable, left and right vent control cables, buzzer wire or cruise control wiring (if so equipped). Disconnect speedometer reset knob.
5. Remove upper left moulding by unsnapping from cluster. Remove exposed screws. See Figure 10-79.
6. Remove nuts from studs along lower edge of cluster. (Remove screws from Riviera cluster lower edge. See Figure 10-91).
7. Remove two nuts from steering column support and lower complete steering column.
8. Remove instrument cluster assembly.

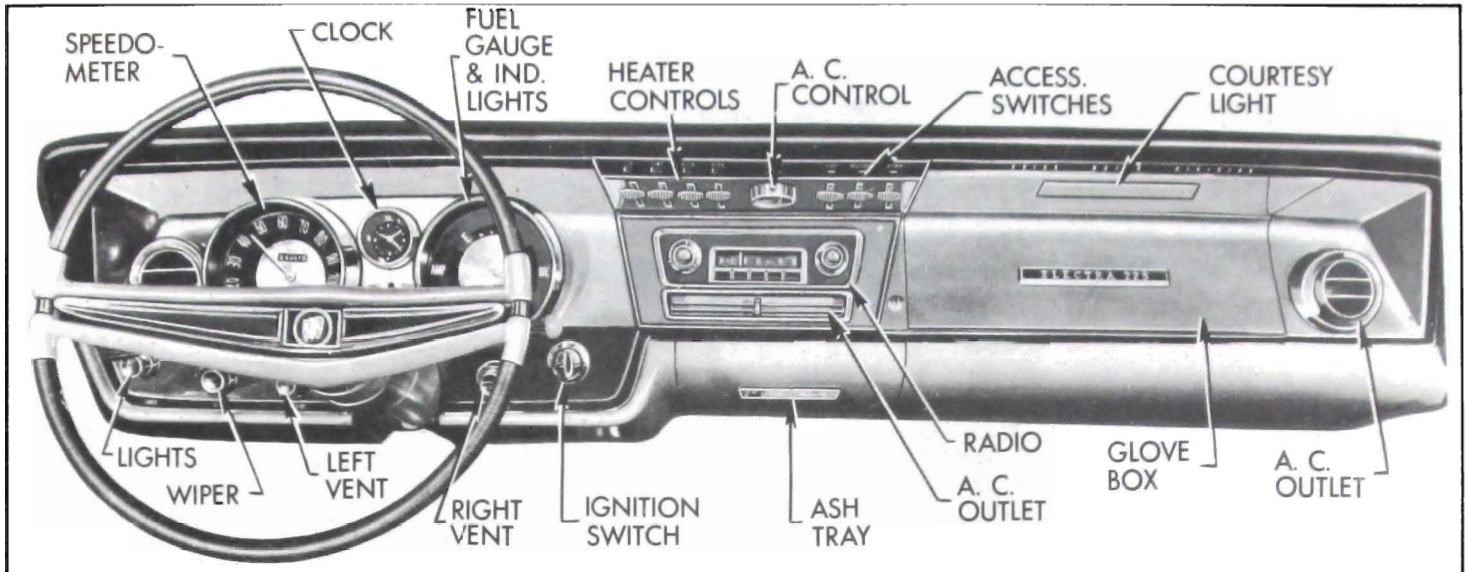

Figure 10-66—Instrument Panel

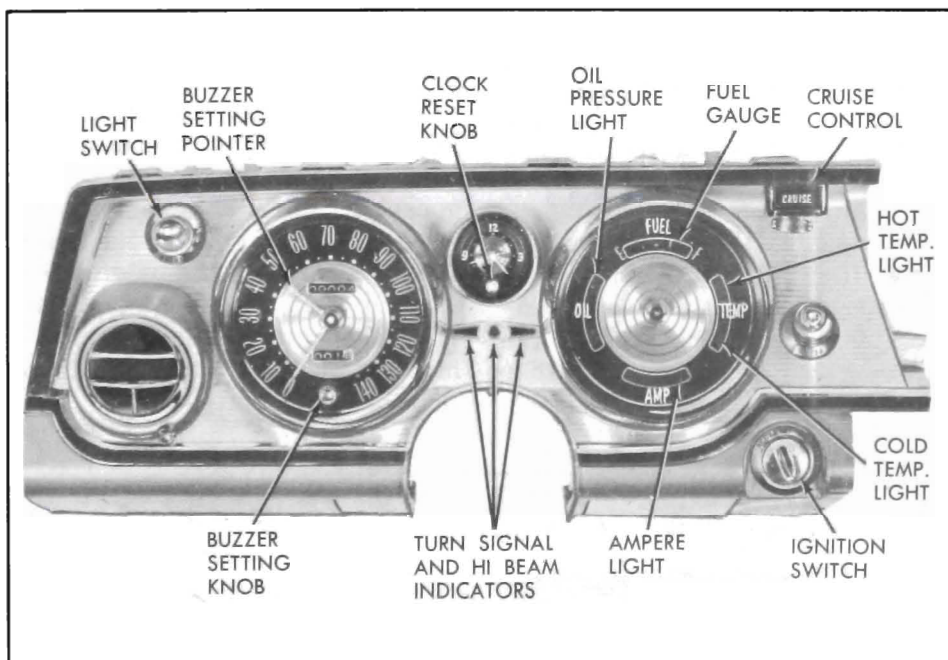

Figure 10-67—Instrument Cluster—Riviera

9. Install by reversing above steps.

c. Generator Charge Indicator

The red "GEN" warning light should light when the ignition is turned "ON" and before the engine is started; if not lighted, either the bulb is burned out or the indicator light wiring has an open circuit. After the engine is started, the "GEN" light should be out at all times; if the light

comes on, the generator belt may be loose or missing, the generator or regulator may be defective, or the charging circuit may be defective. See paragraph 10-18 for trouble-shooting procedures.

To trace the generator indicator light circuit, see Figure 10-70 or 71. With the ignition switch turned on (engine not running), current flow is through the ignition switch, out the "IGN" termi-

nal, through the generator light in the instrument cluster, to the "4" terminal of the regulator, through the lower contacts of the voltage regulator (held closed by the spring), out the "F" terminal of the generator, through the brush and slip ring, through the field, through another brush and slip ring to ground.

Before the engine is started, the generator light should glow at about 1/2 brightness. This is because the voltage in the circuit before the light is about 12 volts, but the voltage at the "4" terminal after the light is about 5 volts. This makes the effective voltage across the generator light approximately 7 volts for about 1/2 brightness.

After the engine is started, the voltage put-out by the generator immediately closes the field relay. This causes battery voltage from the "3" terminal to be present at the "4" terminal. See Figure 10-70 or 71. Since battery voltage is present on both sides of the generator light, the light goes out. If the generator light comes with the engine running, the charging circuit should be tested at the first opportunity to determine the cause of the trouble. See paragraph 10-21.

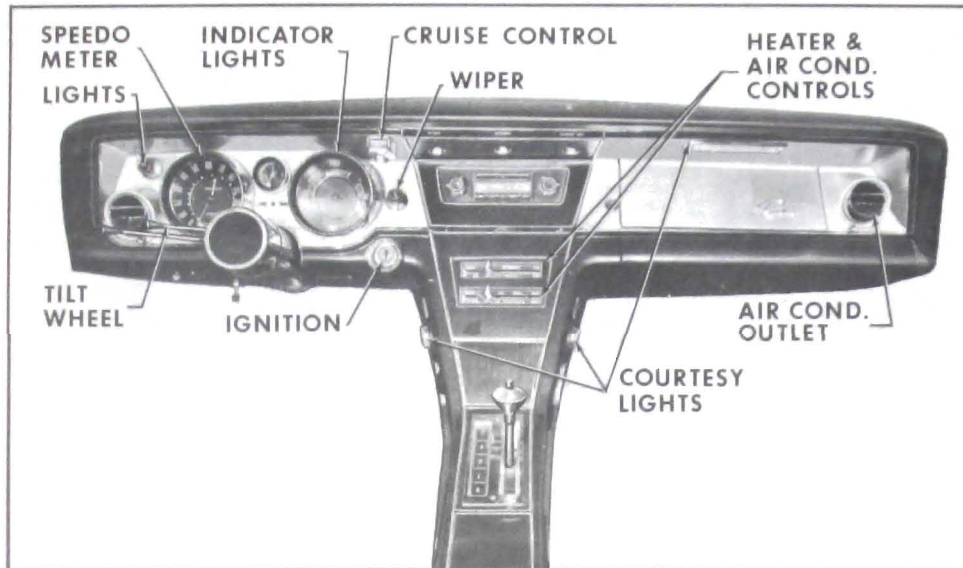

Figure 10-68—Instrument Panel-Riviera

d. Oil Pressure Indicator

The engine oil pressure indicator light is controlled by a pressure operated switch located in the main oil gallery at the right rear of the engine. See Figure 10-148 or 150.

This light should come on when the ignition is turned "on" and the engine is not running. If not lit, either the bulb is burned out, the wiring has an open or the oil switch is defective.

If the engine oil pressure drops below a safe level during operation, the circuit is completed through the pressure switch to ground, and the "Oil" indicator light in the cluster will be turned on.

If the "Oil" indicator stays on or comes on when the engine is running at speeds above idle, the following may be the cause, rather than low oil pressure:

1. Wiring circuit between oil pressure switch and light grounded. Remove connector from pressure switch, if light stays on trouble is in wiring.

2. Switch defective. Replace switch.

e. Temperature Indicator

A temperature switch located in right cylinder head controls the operation of a "Cold" temperature indicator with a green lens and a "Hot" temperature indicator with a red lens. See Figure 10-148 or 150.

When the cooling system water temperature is below approximately 110 degrees F., the temperature switch grounds the "Cold" indicator circuit and the "Cold" on the instrument cluster is lit. When the "Cold" light goes out, the water temperature is high enough so that the heater can be turned on and be effective. The car should never be subjected to full throttle accelerations or high speeds until after the "Cold" light has gone out.

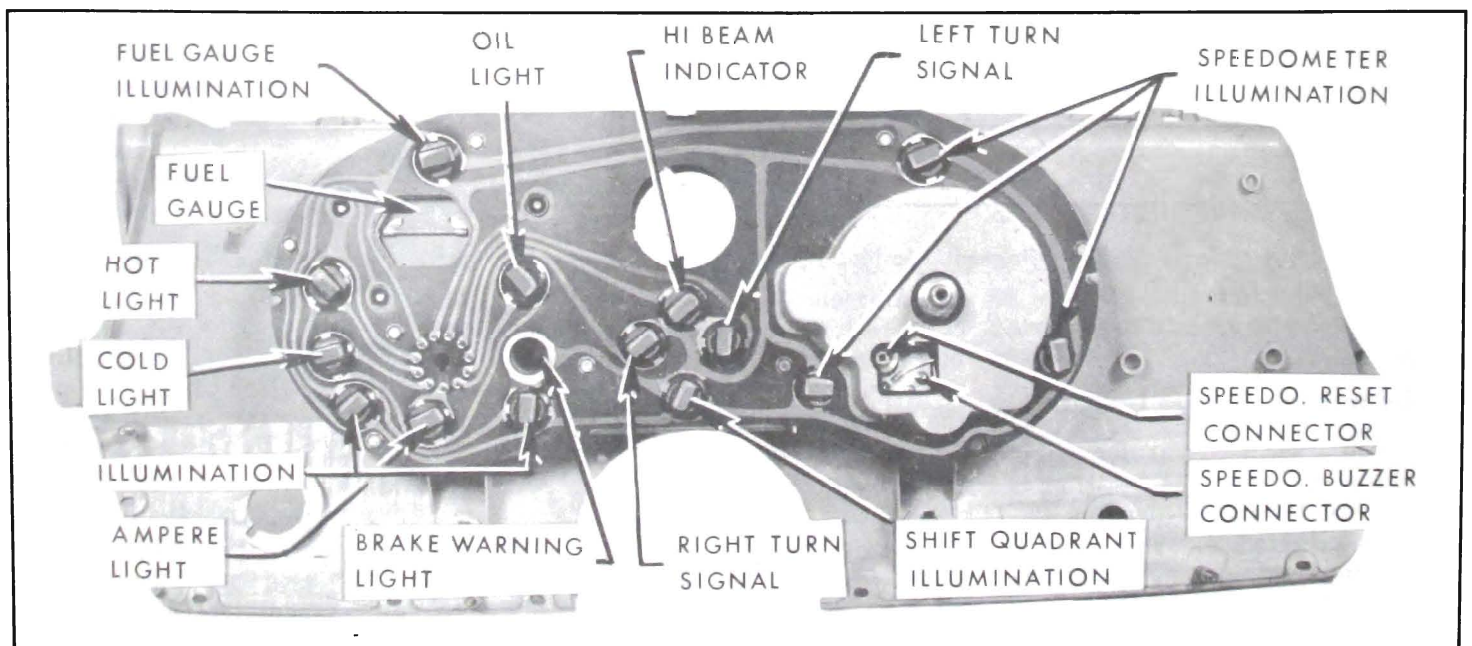

Figure 10-69—Instrument Cluster-Back Side

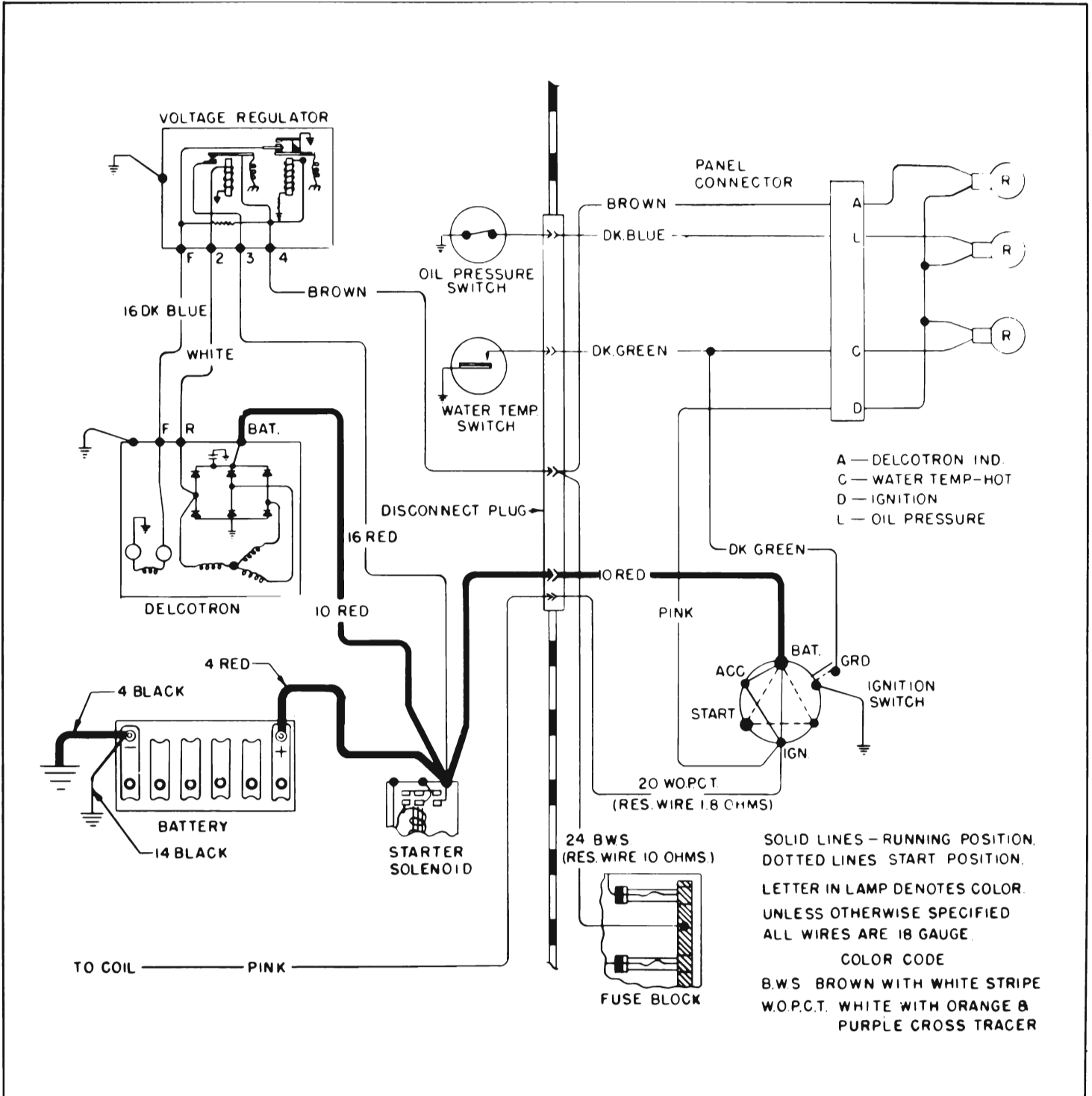

Figure 10-70—Indicator Warning Light Circuits - Series 4400

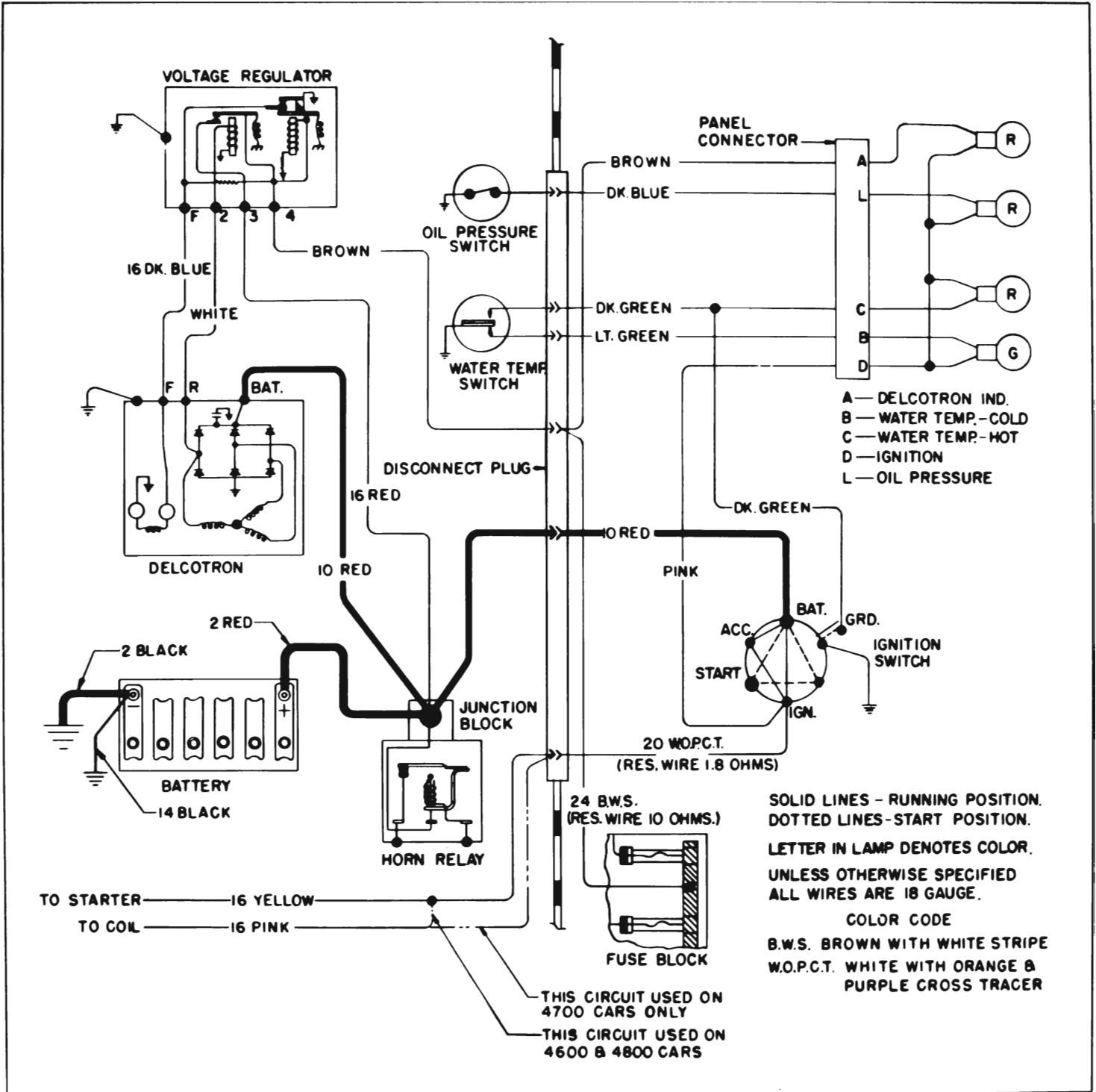

Figure 10-71—Indicator Warning Light Circuits - Series 46-47-4800

| COMPLAINT | POSSIBLE CAUSE |
|---|--|
| <p>1. GENERATOR INDICATOR (See Par. 10-18)</p> <p>Light on, ignition "Off".</p> <p>Light not lit, ignition "On" and engine not running.</p> <p>Light on, engine running above idle speed.</p> | <p>Positive diode shorted. Locate and replace.</p> <p>Bulb burned out. Replace.</p> <p>Open in light circuit. Locate and correct.</p> <p>Positive diode shorted. Locate and replace.</p> <p>No generator output. Check output, paragraph 10-21.</p> <p>Loose or broken generator belt.</p> <p>Resistance or open in field circuit.</p> <p>Defective field-light relay.</p> |
| <p>2. OIL PRESSURE INDICATOR</p> <p>Light not lit, ignition "On" and engine not running.</p> <p>Light on, engine running above idle speed.</p> | <p>Bulb burned out. Replace.</p> <p>Open in light circuit. Locate and correct.</p> <p>Oil pressure switch defective. Replace.</p> <p>Wiring between light and switch grounded. Locate and correct.</p> <p>Oil pressure switch defective. Replace.</p> <p>Oil pressure below 2 lbs. Locate cause and correct.</p> |
| <p>3. TEMPERATURE INDICATORS</p> <p>(a) Hot Indicator</p> <p>Light not lit when cranking engine.</p> <p>Light on, engine running.</p> <p>(b) Cold Indicator</p> <p>Light not lit, ignition "On" and engine cold.</p> <p>Light on, after normal engine warm-up period.</p> | <p>Bulb burned out. Replace.</p> <p>Open in light circuit. Locate and correct.</p> <p>Ignition switch defective. Replace.</p> <p>Wiring between light and switch grounded. Locate and correct.</p> <p>Temperature switch defective. Replace.</p> <p>Cooling system water temperature above 248°F. Find cause and correct.</p> <p>Ignition switch defective. Replace.</p> <p>Bulb burned out. Replace.</p> <p>Open in light circuit. Locate and correct.</p> <p>Water temperature switch defective. Replace.</p> <p>Wiring between light and switch grounded. Locate and correct.</p> <p>Water temperature switch defective. Replace.</p> <p>Thermostat in cooling system defective. Replace.</p> |

If the engine cooling system is not functioning properly and the water temperature should reach approximately 248 degrees F., the "Hot" indicator will be turned on by the temperature switch. As a test circuit to check whether the "Hot" indicator bulb is functioning properly, a wire which is connected to the "GND" terminal of the ignition switch is tapped in to its circuit. See Figure 10-70 or 71. When the ignition is in the "Start" position (engine cranking), the "GND" terminal is grounded inside the switch and the "Hot" indicator bulb will be lit. When the engine is started and the ignition switch is in the "On" position, the test circuit is opened and the bulb is then controlled by the temperature switch.

f. Trouble Diagnosis—Generator Indicator, Oil Indicator, Pressure Temperature Indicator

Use Figure 10-70 or 71 to trace wiring circuits for indicator lights and Figure 10-69 for location of indicator light bulb socket. To determine if there is a ground in the indicator light circuit, remove connector from control switch, if light stays on, trouble is in circuit.

10-49 ELECTRIC CLOCK

The electric clock is mounted in the center of the instrument cluster. The clock wiring circuit is



Figure 10-72—Electric Clock

protected by the "CLOCK" fuse on the fuse block. The clock light is controlled by the rheostat in the lighting switch and is protected by the "INST. LTS." fuse on the fuse block. If burned out, this bulb is accessible by removing one of the lower access doors.

a. Clock Time Reset and Automatic Regulation

The electric clock has a sweep-second hand and an automatic regulator. A reset knob extends through the glass at the bottom of the clock dial. To reset the time, pull the knob out and turn in either direction as required. See Figure 10-75.

There is no regulator knob because regulation is accomplished automatically by the action of resetting the time. If a clock is running fast, the action of turning the hands back to correct the time will automatically cause the clock to run slightly slower; if a clock is running slow, the action of turning the hands forward to correct the time will automatically cause the clock to run slightly faster (10 to 15 seconds per day).

A lock-out feature prevents the regulator mechanism from being moved more than once during a rewind period (approximately 3 minutes), regardless of the number of times the clock reset is operated. After clock rewinds, if it is again reset, automatic regulation will take place.

b. Clock Service

The clock manufacturers have established Authorized Service Stations in many cities throughout the United States and Canada. These service stations are prepared to carry out terms of the manufacturer's warranty and also to perform any repairs made necessary through use of clock.

When a clock requires warranty service or repairs other than regulation, it should be removed by the Buick dealer and sent to the nearest authorized service station. The manufacturer's warranty is void if repairs have been attempted outside of an authorized service station.

10-50 GASOLINE GAUGE SYSTEM—DESCRIPTION AND OPERATION

The gasoline gauge system consists of a dash unit (located in the instrument cluster), a tank unit (located in the gasoline tank), a wire between these two units, and a wire to supply battery voltage to the dash unit. See Figure 10-73. The single tank unit terminal is connected to one dash unit terminal with a tan wire. The other dash unit terminal is connected to the ignition switch with a pink wire so that voltage to energize the system is supplied only when the ignition switch is turned on. The dash unit has a balanced-type pointer; when the ignition is turned off, the pointer may come to rest any place on the dial.

The dash unit pointer is moved by changing the balance between the magnetic pull of two coils in the unit. This balance is controlled by action of the tank unit which contains a variable rheostat, the value of which varies with movement of a float and arm. The tank unit is mounted in the tank so that the float rises and falls on the surface of the gasoline. The float is adjusted to provide approximately 1 gallon reserve when the dash unit pointer is at the dot next to the "E" position.

When the ignition switch is "On" and the tank unit arm is in the full position (maximum resistance for the tan wire to ground), the current flow to ground is through the resistor, battery coil and the

ground coil. Due to the fact that the ground coil has more windings than the battery coil it builds up a stronger magnetic field and the dash unit pointer is pulled to the "F" position. See Figure 10-73. When the tank unit arm is in the empty position (no resistance for tan wire to ground), the current flow is through the resistor, the battery coil and the tan wire to ground at the tank unit. The dash unit pointer is thus pulled to the "E" position.

10-51 GASOLINE GAUGE—TROUBLE DIAGNOSIS

If the gasoline gauge does not operate properly, the dash unit, tank unit wiring and the tank unit should be separately tested to determine which is at fault. The units and wiring may be tested by using a known good tank unit with a 12 foot piece of red insulated (#16) wire attached to binding post of unit and a similar 5 foot piece of black wire attached to flange of unit. Attach a spring clip to end of black wire and a terminal to end of red wire.

1. Test of Wiring Between Dash Unit and Tank Unit.

(a) Disconnect the tank unit tan wire at frame side rail. This connector is located at top of right frame rail just forward of gas tank on all models except estate wagons. On estate wagons the connector is located at the left front corner of gas tank.

Plug the red test wire terminal into the connector and attach the black test wire to any convenient ground on the car.

(b) Turn ignition switch on and move arm of test unit up and down against the stops while observing dash unit. If dash unit and wiring are okay, dash unit pointer will move freely from "Empty" to "Full" with movement of tester arm, indicating that trouble is in tank unit or the short wire leading to it.

(c) If, on the test of dash unit and tank unit wiring, dash unit reads "Empty" or noticeably low at all times, look for a ground in the wiring circuit between dash unit and connector at frame rail. Also an improper grounded dash unit will cause unit to read low. If dash unit reads above "Full" or noticeably high at all times during test, look for points of high resistance or open circuit in wiring.

(d) To eliminate the tank unit brown wire which runs through body to connector at frame rail, remove the left kick pad and unplug wiring harness connector. Contact brown wire in connector with red wire of test unit, ground test unit and turn ignition switch on. If the dash unit functions properly with movement of test unit arm, trouble was caused by the brown wire.

2. Test of Dash Unit

(a) Disconnect wiring connector under left kick pad. Attach test unit red wire to connector tan wire leading to dash unit; attach test unit black wire to ground.

(b) Make sure multiple connector at instrument cluster is plugged in securely.

(c) Turn ignition on. Move arm of test unit up and down against stops. If dash unit pointer moves freely from "E" to "F" with movement of tester arm, dash unit is okay. If pointer does not move or only moves part way, printed circuit may be defective, dash unit may not be grounded properly, or dash unit may be faulty.

(d) Before removing complete

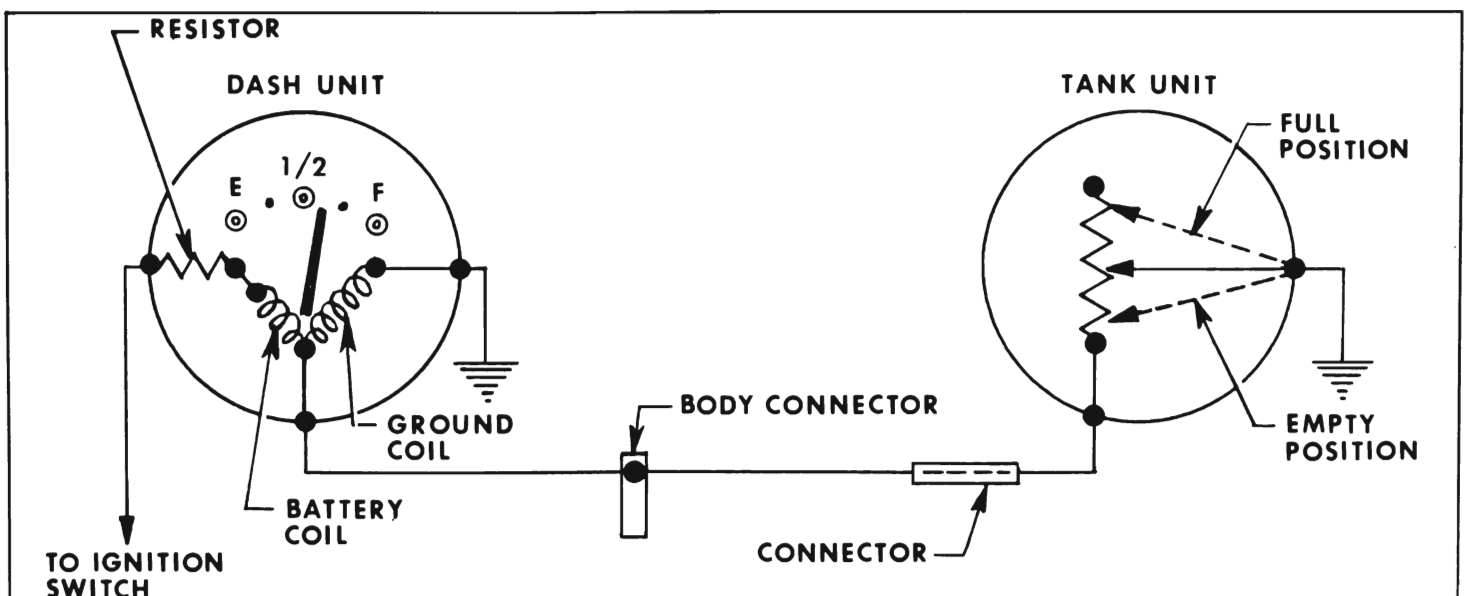

Figure 10-73—Gasoline Gauge Circuit

instrument cluster to check printed circuit, try replacing dash unit with a known good unit as follows:

- (1) Remove Allen set screw from bezel and remove bezel.
- (2) Remove dial face.
- (3) Remove three screws from dash unit and remove unit.
- (e) If pointer of new dash unit will not move properly with movement of tester arm, printed circuit is probably defective. Remove instrument cluster assembly as described in paragraph 10-48, b.

3. Test of Tank Unit.

(a) If tests given above indicate that the trouble is in the tank unit, check the tank unit wiring and if necessary, remove the unit so that it may be cleaned and tested. Tank unit is accessible through trunk compartment by removing cover from floor pan (except in wagons or Rivas.)

(b) After thorough cleaning of tank unit, connect it to ground and to wire leading to dash unit, and test in the same manner as when using tester. If tank unit tests okay it should be reinstalled in tank, otherwise, it should be replaced with a new unit. When installing tank unit make certain that insulation is folded over the terminal and snapped over wire.

10-52 SPEEDOMETER

a. Speedometer Heads

The speedometer head has a magnetic speed indicator and a gear driven odometer. It is driven by a flexible cable connected to a worm gear in the transmission rear bearing retainer.

The speed indicating portion of the speedometer operates on the magnetic principle. There is a permanent magnet in the speedometer head which rotates at the same speed as the cable. This

magnet exerts a pull on a speed cup causing it to move through an arc in direct ratio to the revolving magnet speed. A pointer is attached to the speed cup spindle to indicate speed on the speedometer dial. A calibrated hair spring (part of speed cup) opposes the magnetic pull on the speed cup so the pointer indicates speed accurately; this spring also rotates the cup and pointer to zero when the car stops.

Some speedometers have a trip odometer and a reset knob. Pushing the reset knob in and turning clockwise gives a quick reset to zero; turning the knob counterclockwise resets the trip odometer 1/10 mile at a time. Speedometers which have the trip odometer also have either the safety buzzer or the cruise control.

b. Checking Noisy Speedometer

1. Jack up rear wheels in a safe manner and close car windows to exclude outside noises.
2. With transmission in direct drive, run slowly from 0 to 50 MPH and back to 0, noting speed range where noise appears.
3. Apply brakes and shift transmission to park position, then run engine through same speed range as before.
4. If the noise continues even with the transmission output shaft stationary, something other than the speedometer installation is at fault.
5. If noise disappears with transmission stationary, check further for cause of noise by checking for proper installation of speedometer cable as shown in Figure 10-74 or 75.
6. If cable installation is okay, next remove inner cable from casing. Lay inner cable on clean paper to keep dirt from cable

lubricant. Reconnect empty casing to speedometer and recheck for noise at various speeds. If noise still continues, noise is coming from transmission rather than from speedometer or cable.

7. If noise stops with inner cable removed, speedometer or cable is at fault. Inspect cable as described in subparagraph c.

c. Inspection of Speedometer Cable and Casing

If the speedometer installation appears to be noisy or the speed indicator wavers, inspect the cable casing for damage, sharp bends, or for being out-of-position in the supporting clips. See Figure 10-74 or 75. If casing is in good condition and properly installed, remove inner cable for inspection.

1. Disconnect cable casing at speedometer head, then pull inner cable out of upper end of casing.
2. Inspect cable for worn spots or breaks. Check cable for kinks by holding one end vertically in each hand and turning cable slowly; if cable is kinked, the loop will "flop". Replace a cable which has kinks or bent tips.
3. Before installing a new inner cable, work AC spec. 640 speedometer cable lubricant into the cable thoroughly, then wipe off all excess lubricant. Since the speedometer casing has a Delrin (plastic) liner, this lubricant is used as a rust preventive only.
4. If noise is still present, install a new speedometer cable assembly.
5. If this does not correct noise, have speedometer head checked by a UMS Service Station.

d. Trouble-Shooting Speedometer Safety-Buzzer

The safety-buzzer consists of a buzzer which may be adjusted by the driver to sound at any speed

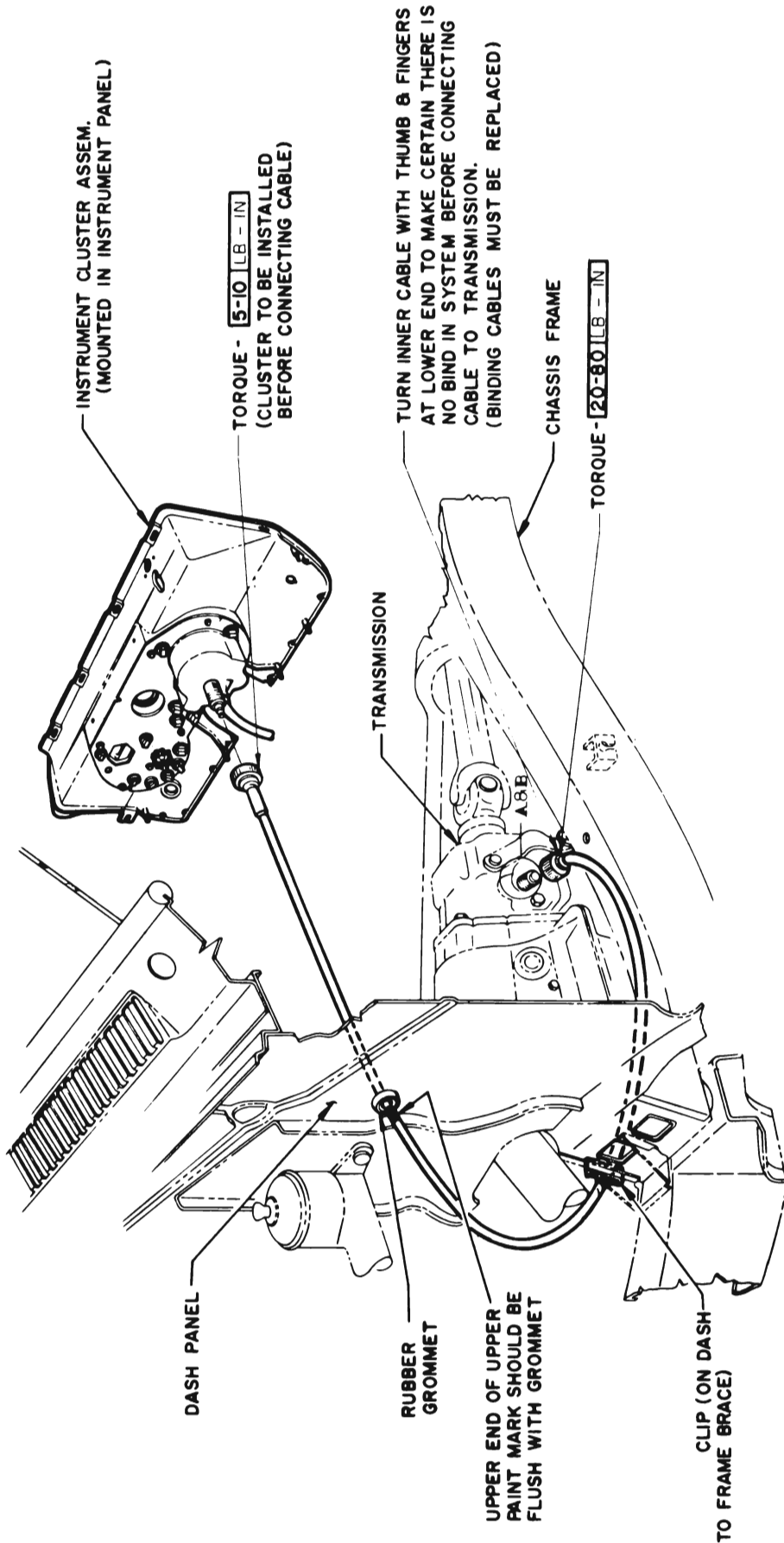

Figure 10-74—Speedometer Cable Installation

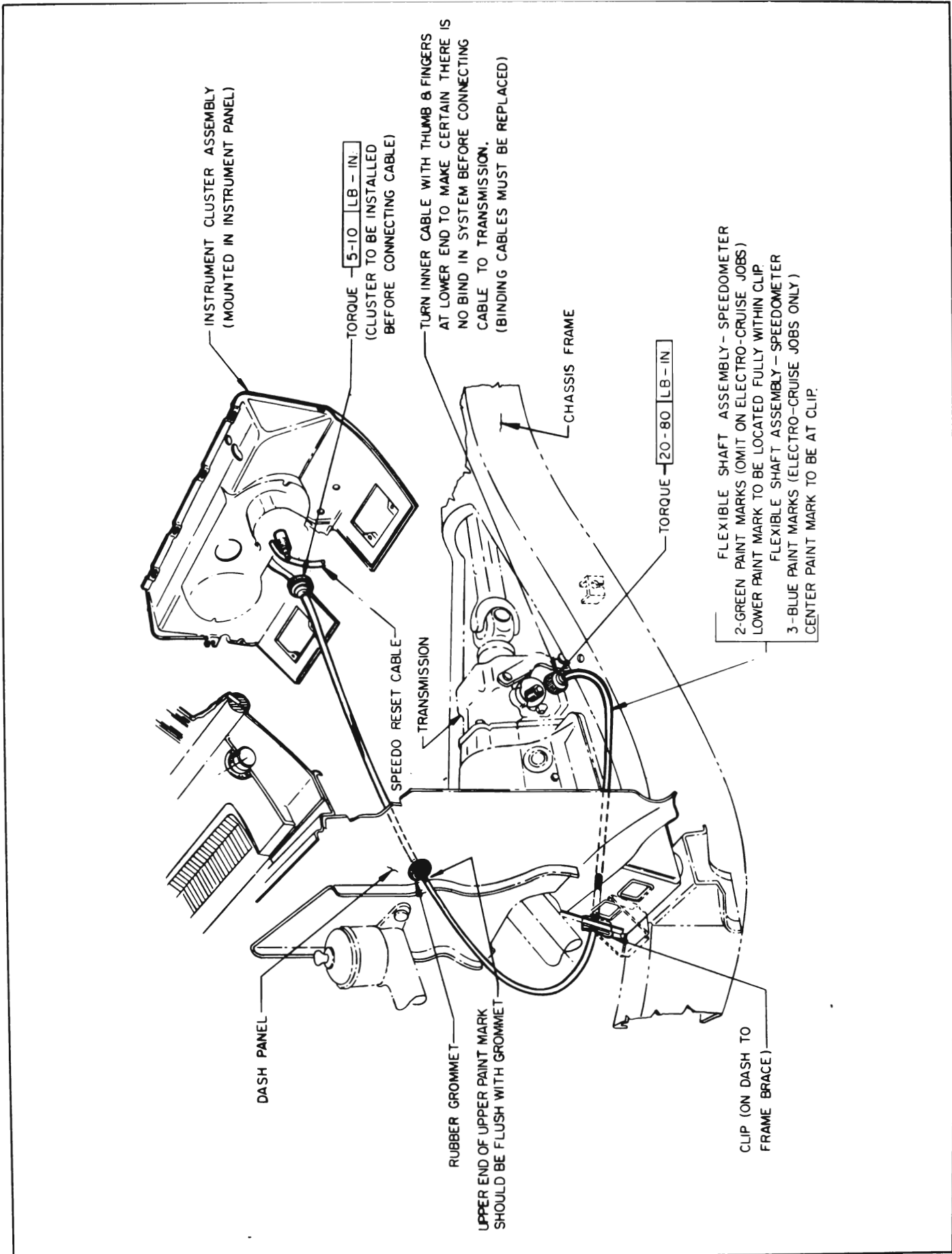

Figure 10-75—Speedometer Cable Installation—Riviera

between 30 and 90 MPH by turning a knob at the bottom of the speedometer face. See Figure 10-69. The speed at which the safety-buzzer is set is indicated by a special pointer with a yellow ball in the speedometer face. When the pointer is turned to the end of its travel (90 MPH), the buzzer turns off.

The safety-buzzer electrical circuit starts at a 6 ampere fuse marked "BK & BZ" located on the fuse block. Since this fuse also protects the parking brake warning light, a functioning warning light indicates that this fuse is OK. This circuit is "hot" whenever the ignition switch is turned on. From the fuse, a dark green wire carries the current to a buzzer mounted on a bracket located under right side of instrument cluster. See Figure 10-136. After passing through the buzzer contacts, a very small amount of current goes through a resistor to ground and the rest of the current passes through a blue wire to the connector plug located on the speedometer case.

In the speedometer, current is conducted from the separate buzzer connector through a wire to an insulated pin in the lower end of the safety-buzzer pointer. As the speedometer pointer moves up to coincide with the safety-buzzer pointer, a light grounding hair spring on the lower end of the speedometer pointer makes contact with the "hot" insulated pin on the safety-buzzer pointer.

This grounds the circuit, causing the buzzer to buzz. If the car speed is increased beyond the safety-buzzer setting, the insulated pin on the safety-buzzer pointer "picks-up" the hair spring as the speedometer pointer passes under the safety-buzzer pointer and the light grounding hair spring winds-up slightly.

1- Buzzer Will Not Operate Or Operates Intermittently.

- (a) Turn ignition switch on.
- (b) To check buzzer, stick a prod in terminal at buzzer connector with the blue wire and run jumper to ground. If buzzer now operates, circuit is OK through buzzer and trouble must be in wire to speedometer or in speedometer. To check buzzer circuit up to speedometer, stick prod in buzzer connector at speedometer and run jumper to ground. See Figure 10-69. If buzzer operates, circuit is OK to speedometer so trouble must be in speedometer.

(c) If buzzer did not operate when buzzer connector was grounded (in Step b), trouble may be in buzzer circuit. Check "BK & BZ" fuse on fuse block and replace 6 ampere fuse if necessary.

NOTE: Since this fuse also protects the parking brake warning light, a functioning warning light indicates that this fuse is OK.

(d) Check buzzer circuit wiring connectors at fuse block and at buzzer.

(e) Next eliminate buzzer as source of trouble by unplugging connector at buzzer. Then plug a known good buzzer onto the connector and ground buzzer.

2. Buzzer Operates Continuously

- (a) Check blue wire from buzzer to speedometer for ground.
- (b) Remove buzzer connector at speedometer. If buzzer stops, circuit is grounded inside speedometer and speedometer must be removed for repair. If buzzer still operates, however, buzzer unit is defective and must be replaced.

3. Speedometer Defective

A defective speedometer assembly must be sent to the nearest UMS Service Station for repairs.

10-53 ACCESSORY SWITCHES ON CONTROL PANEL

The accessory switches are mounted on a control panel located above the radio trim plate. These switches operate the power rear window on estate wagons, the power top on convertibles, the power antenna and the courtesy light, when so equipped. See Figure 10-87.

To remove one of these switches, it is necessary to first remove the control panel.

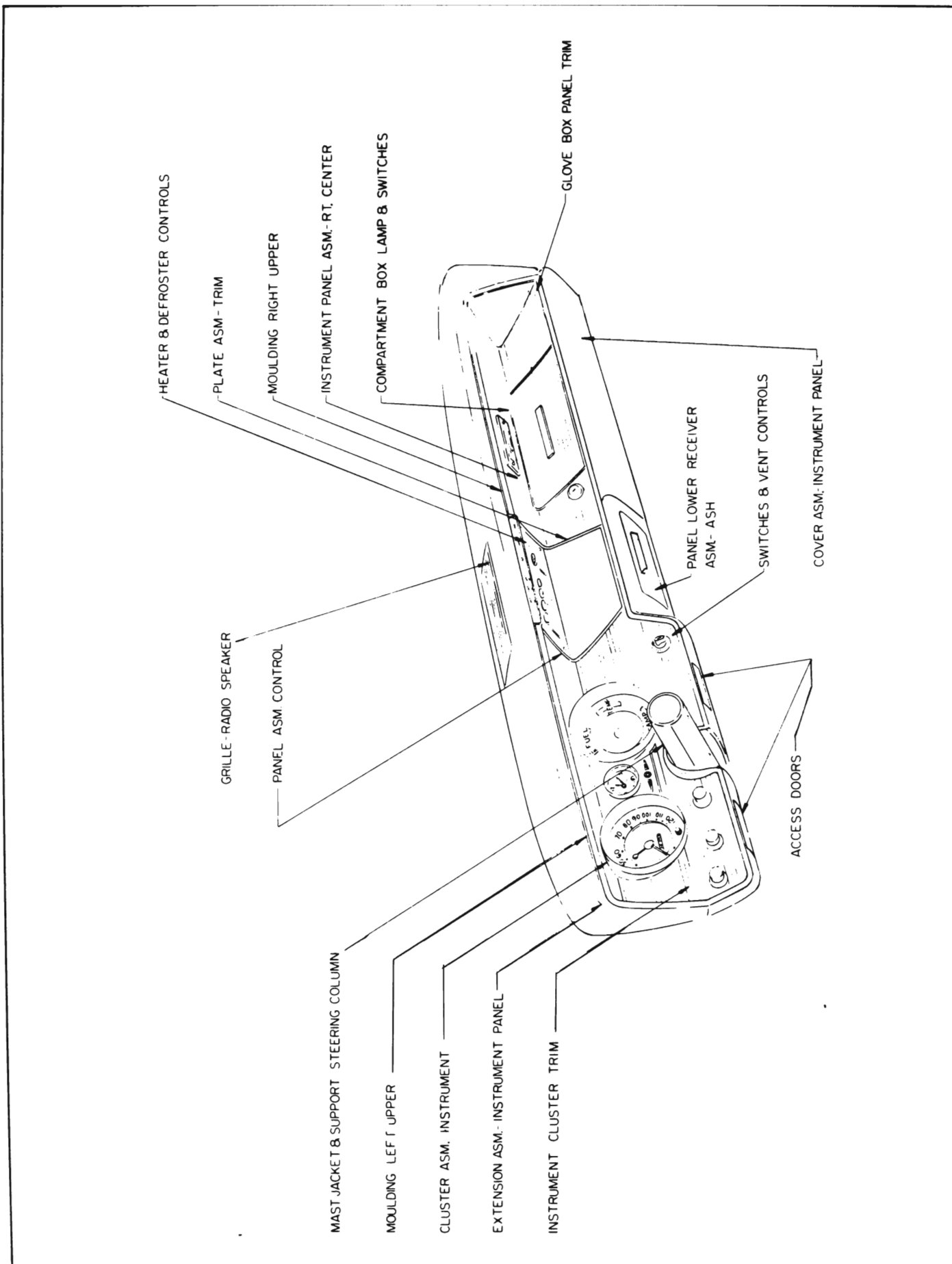

Figure 10-76—Instrument Panel Installation - Index

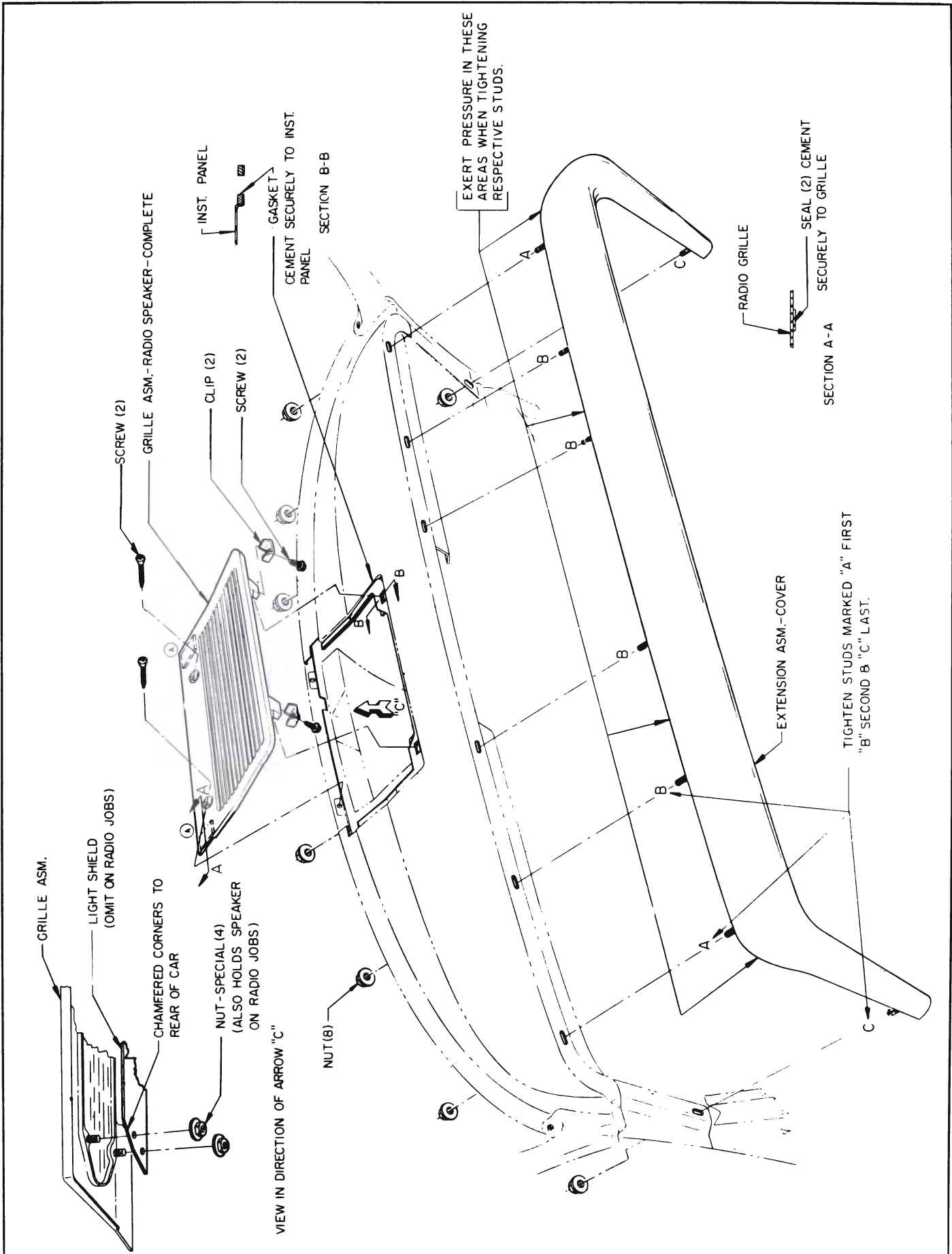

Figure 10-77—Extension and Radio Grille Installation

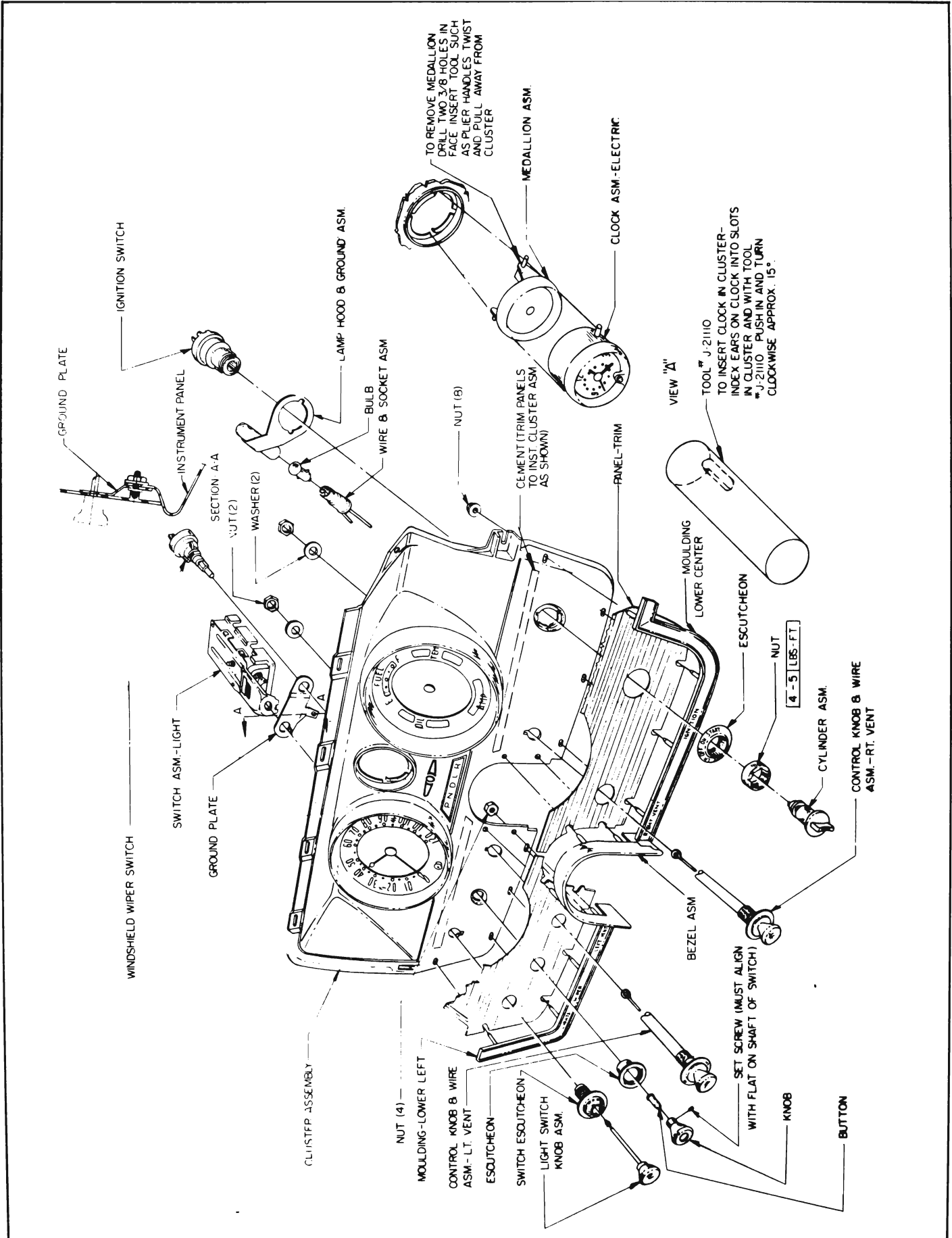

Figure 10-78—Instrument Cluster Assembly

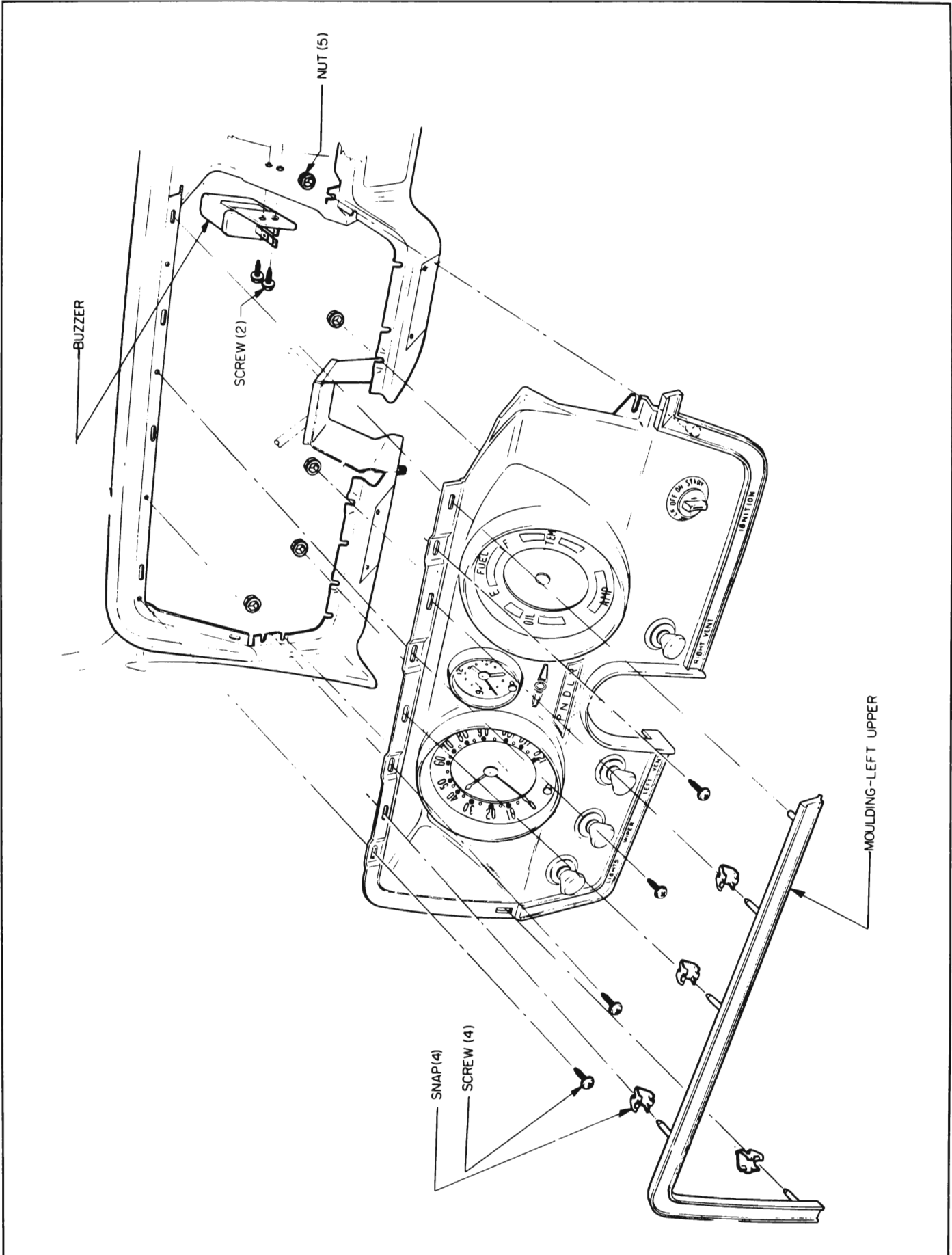

Figure 10-79—Instrument Cluster Installation

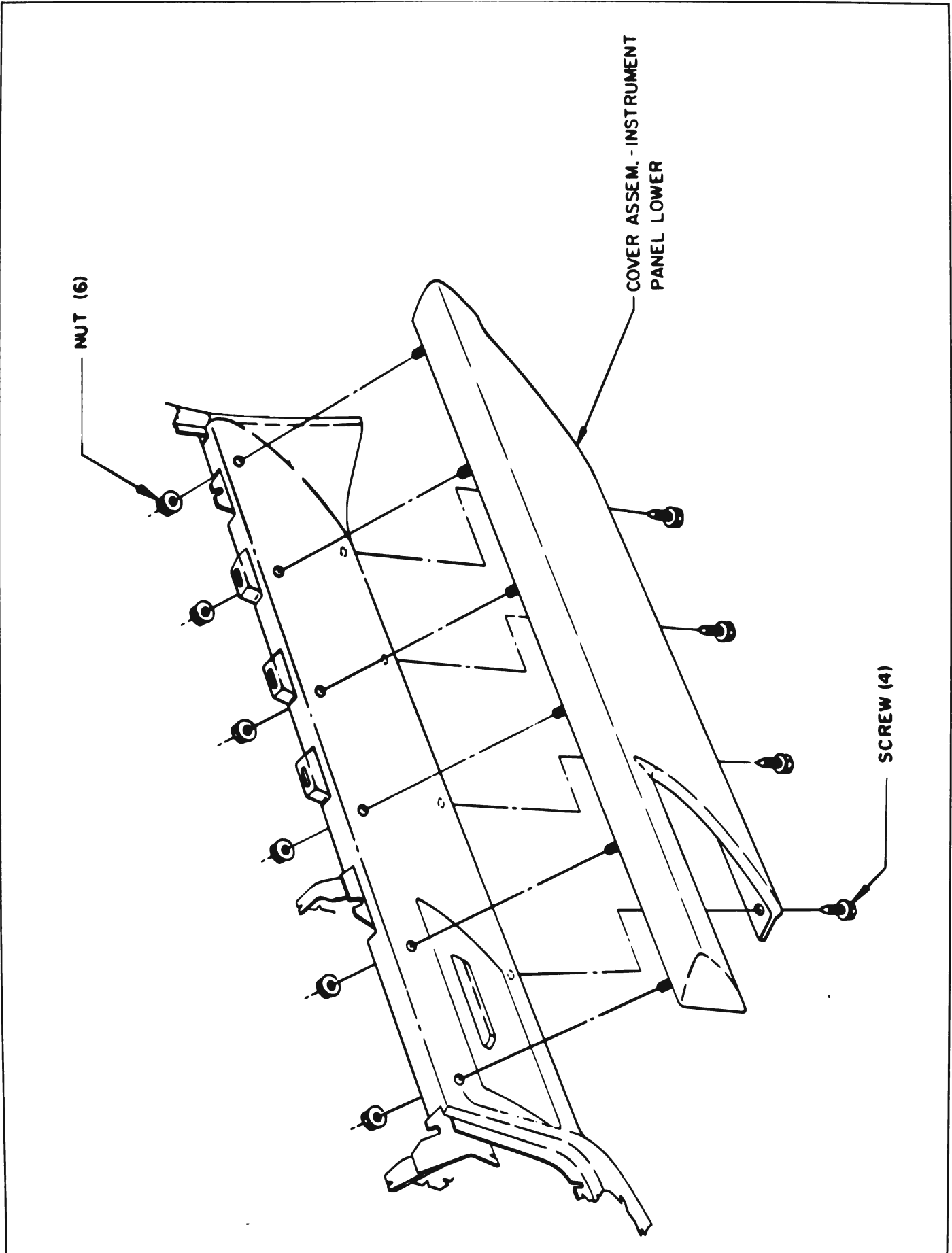

Figure 10-80—Instrument Panel Lower Cover Installation

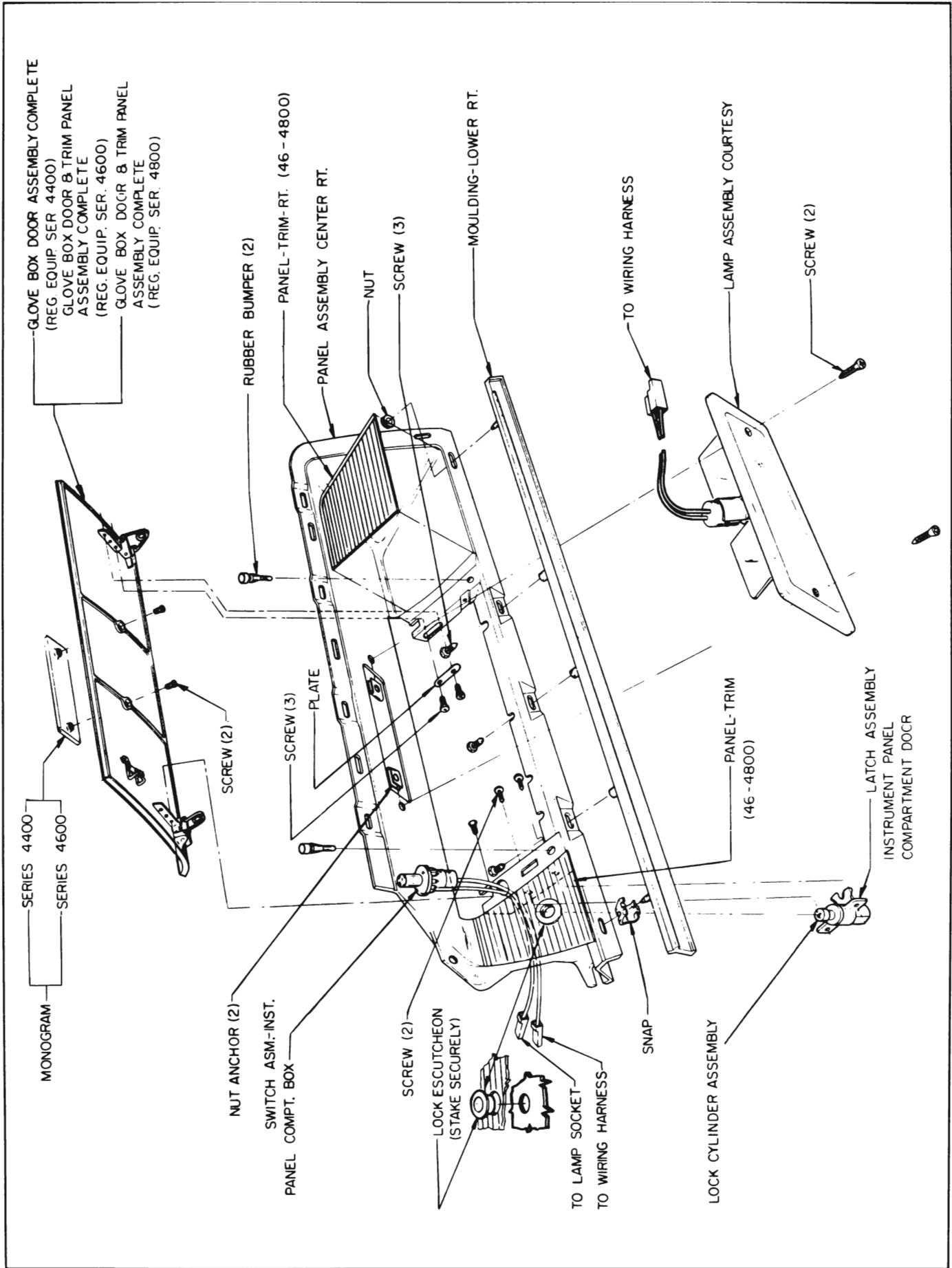

Figure 10-81—Right Center Instrument Panel Assembly

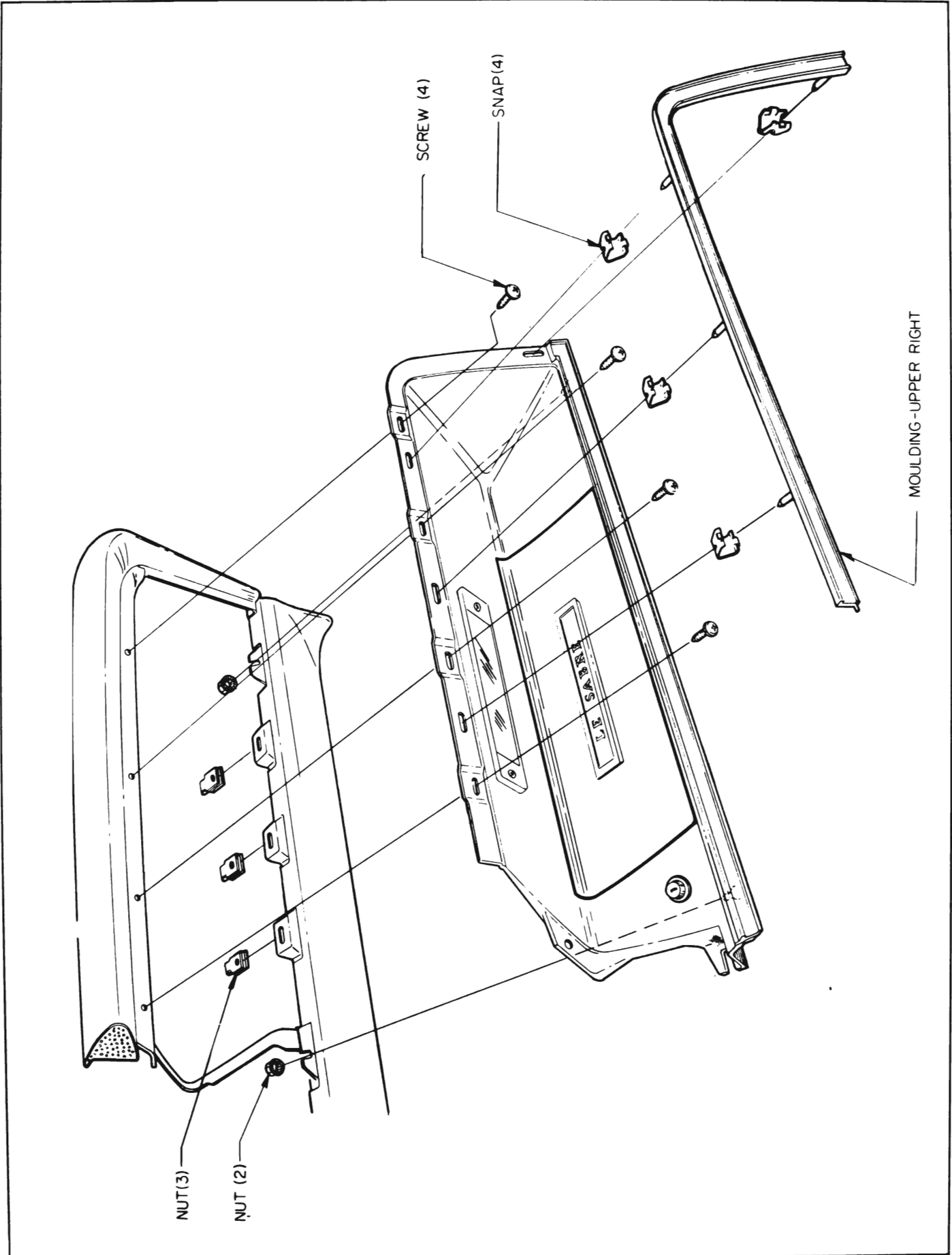

Figure 10-82—Right Center Instrument Panel Installation

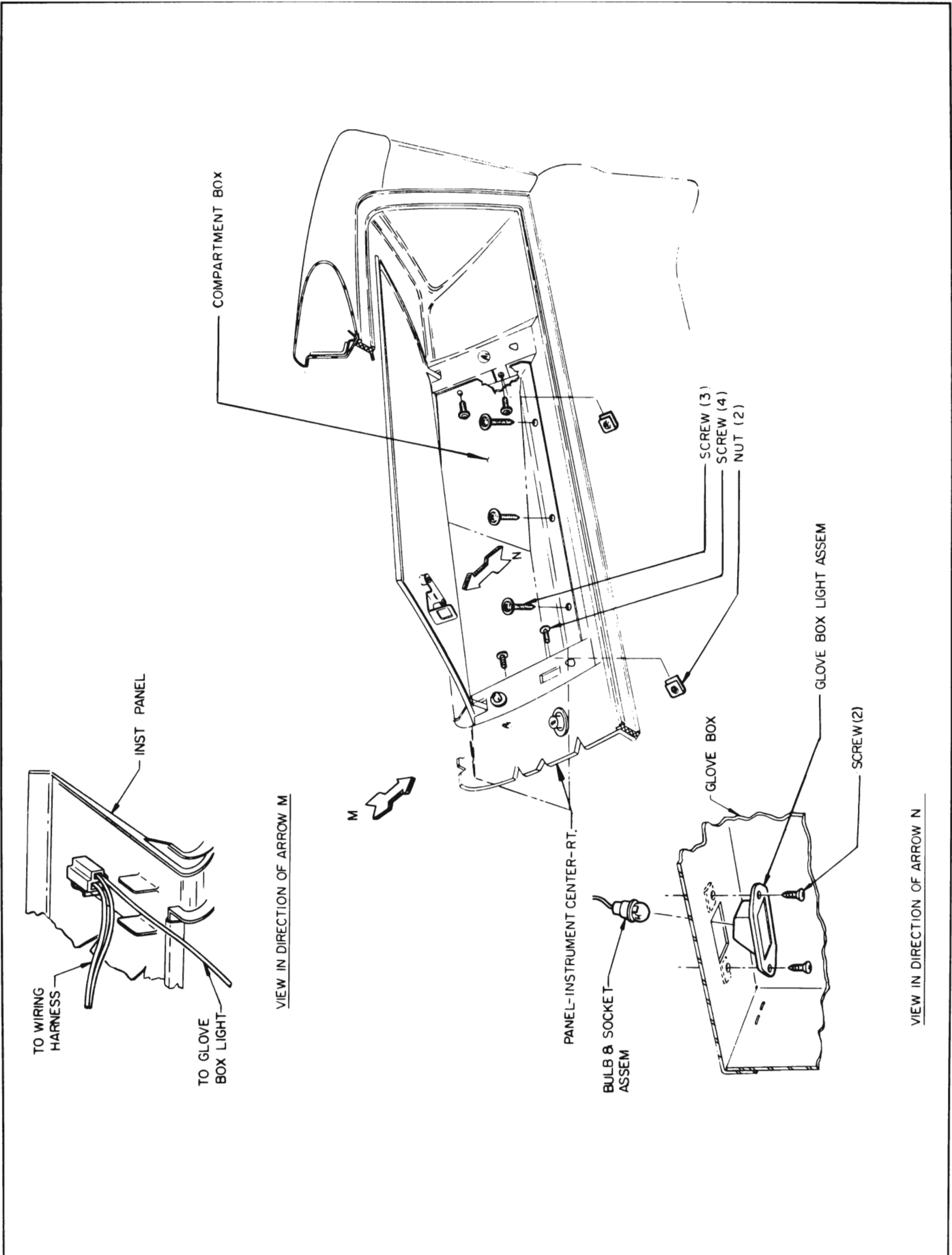

Figure 10-83—Glove Box Installation

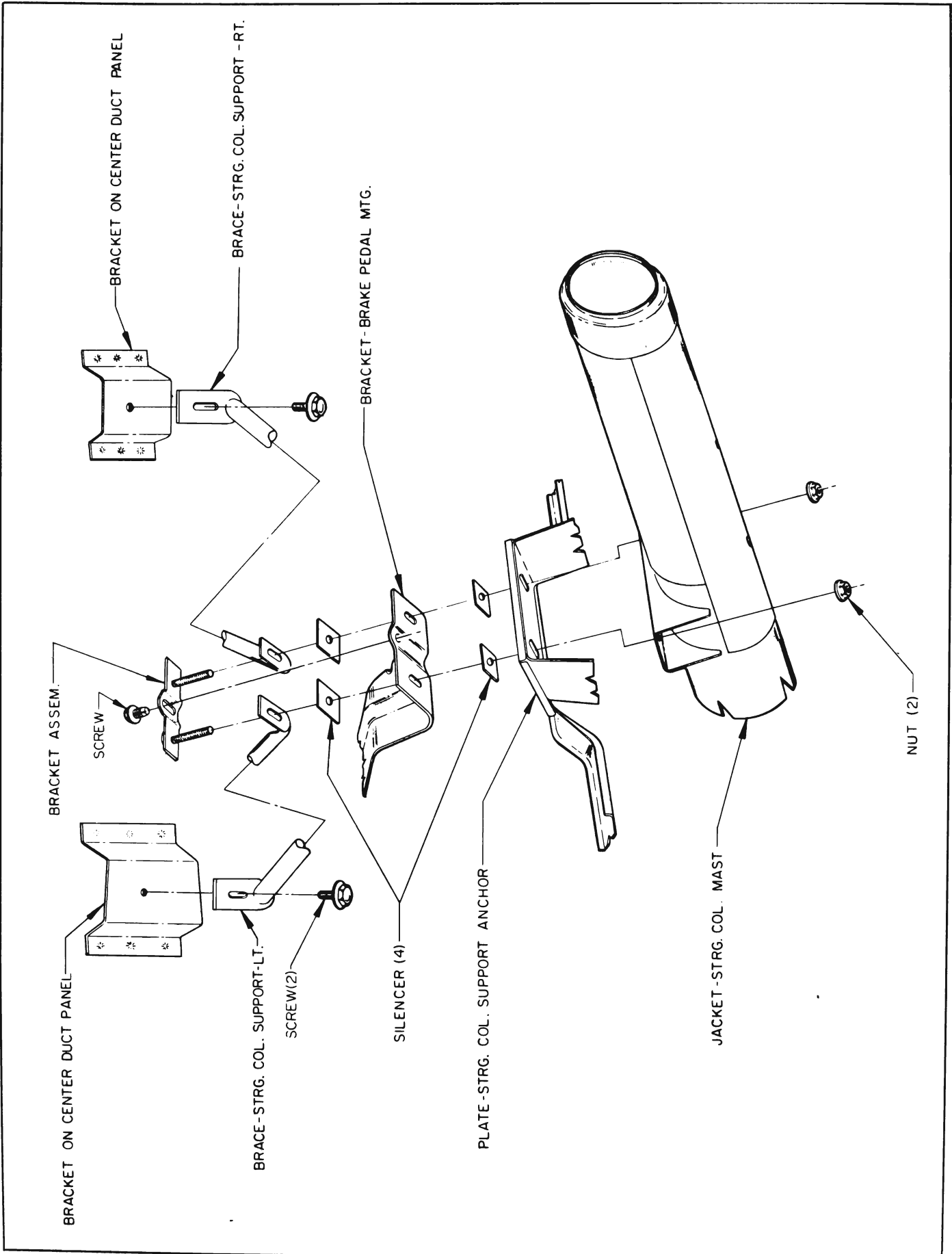

Figure 10-84—Steering Column Installation

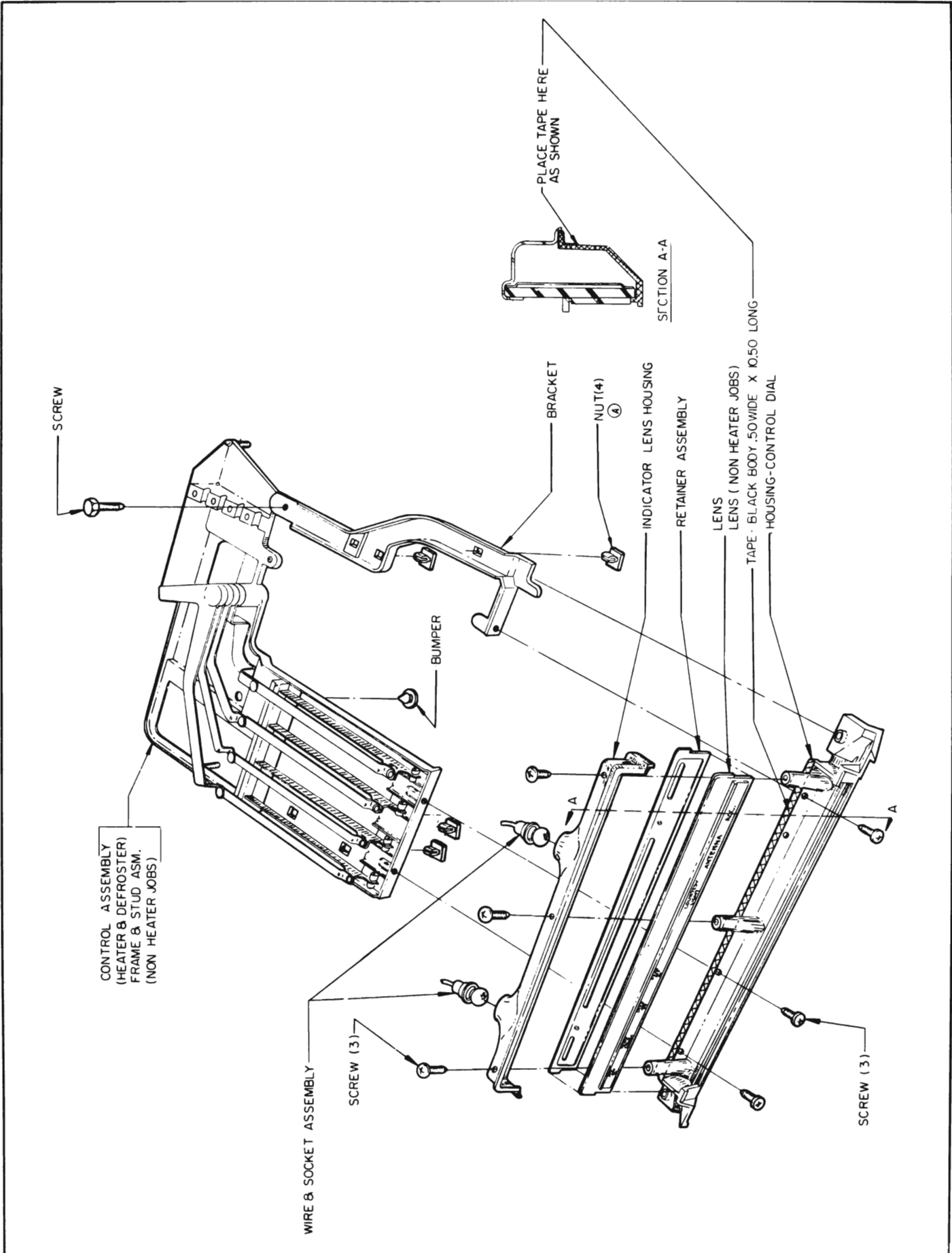

Figure 10-85—Heater Control Assembly

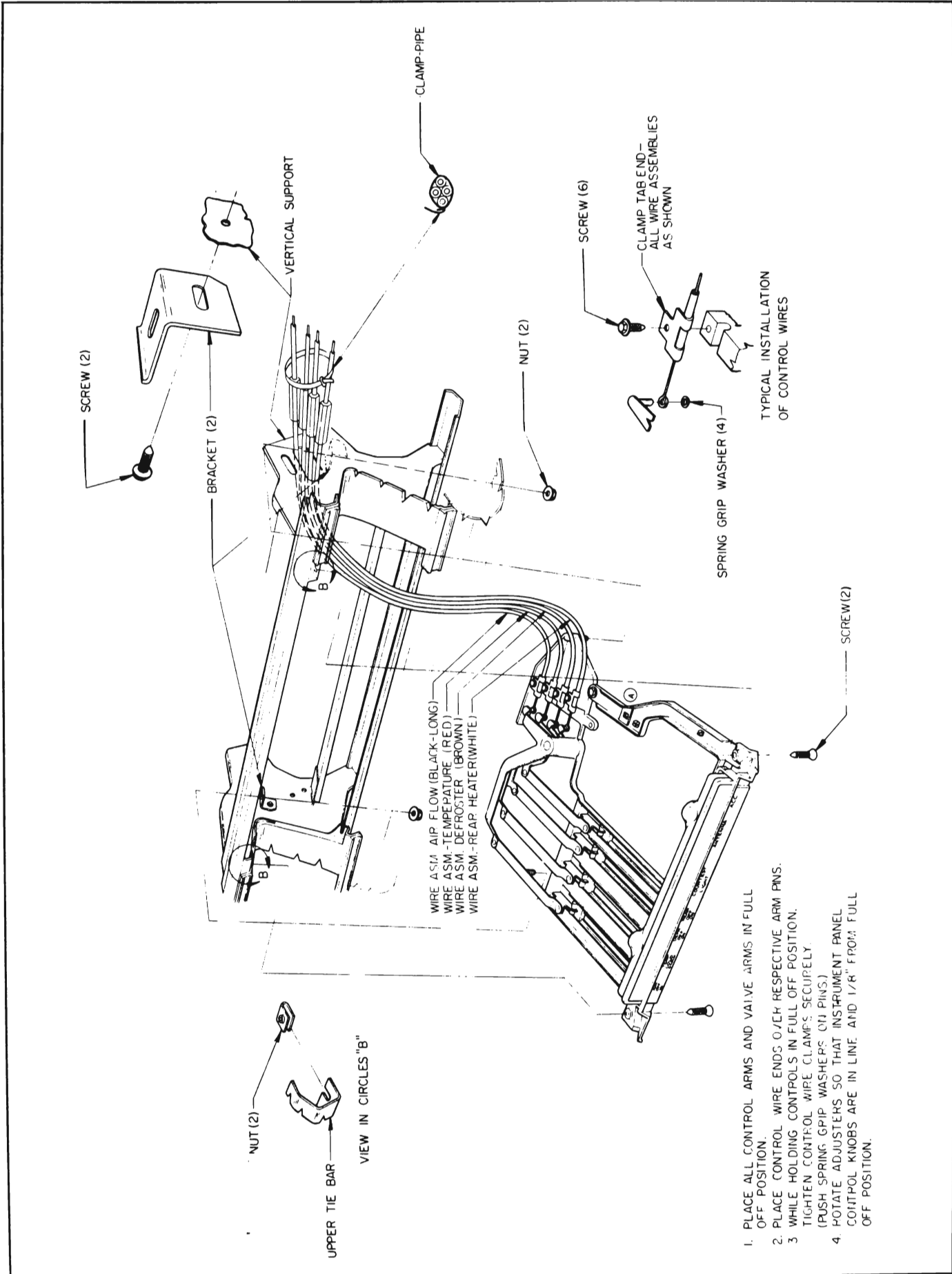

Figure 10-86—Heater Control Adjustment

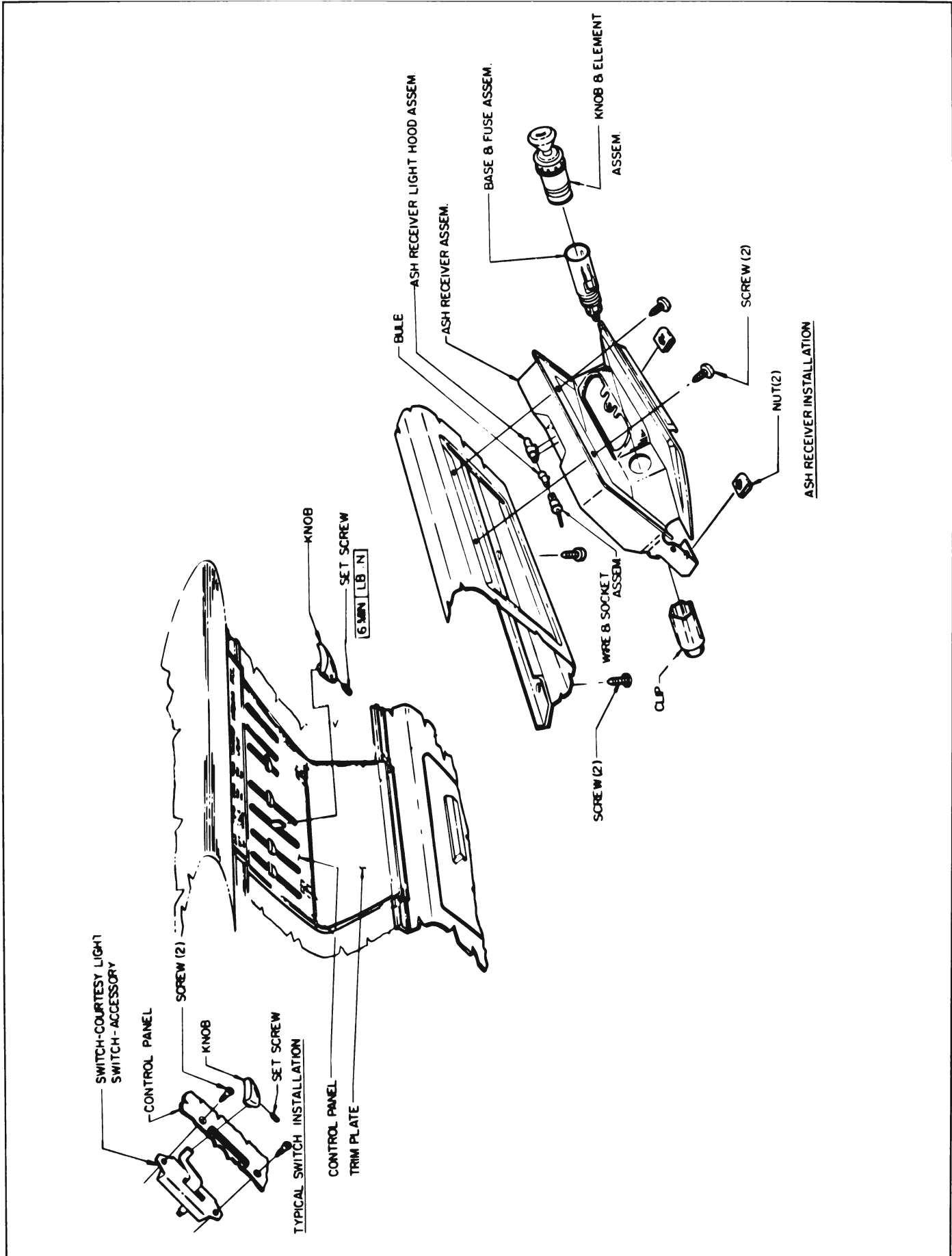

Figure 10-87—Control Panel and Ash Tray Installation

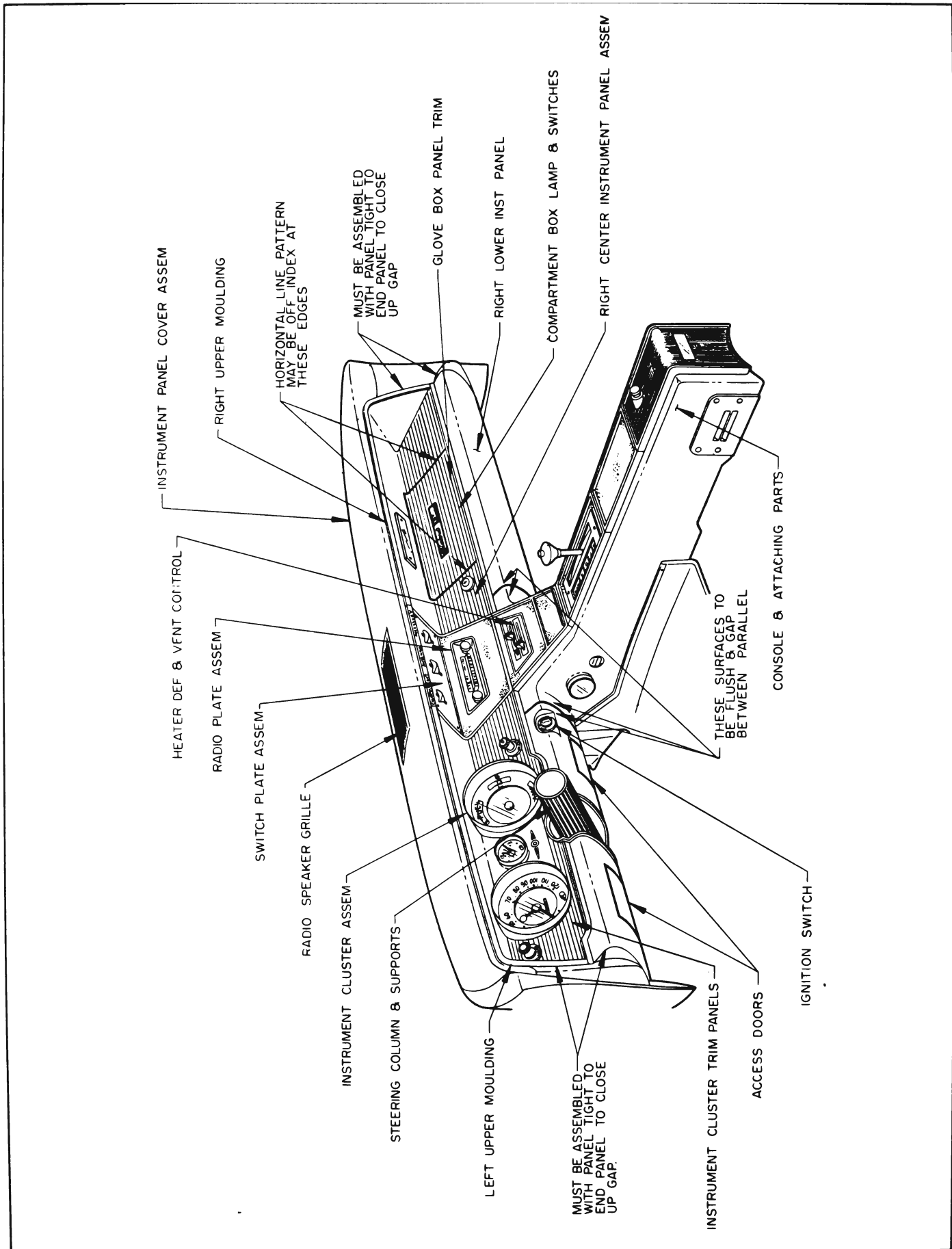

Figure 10-88—Instrument Panel and Console Installation - Index (Riviera)

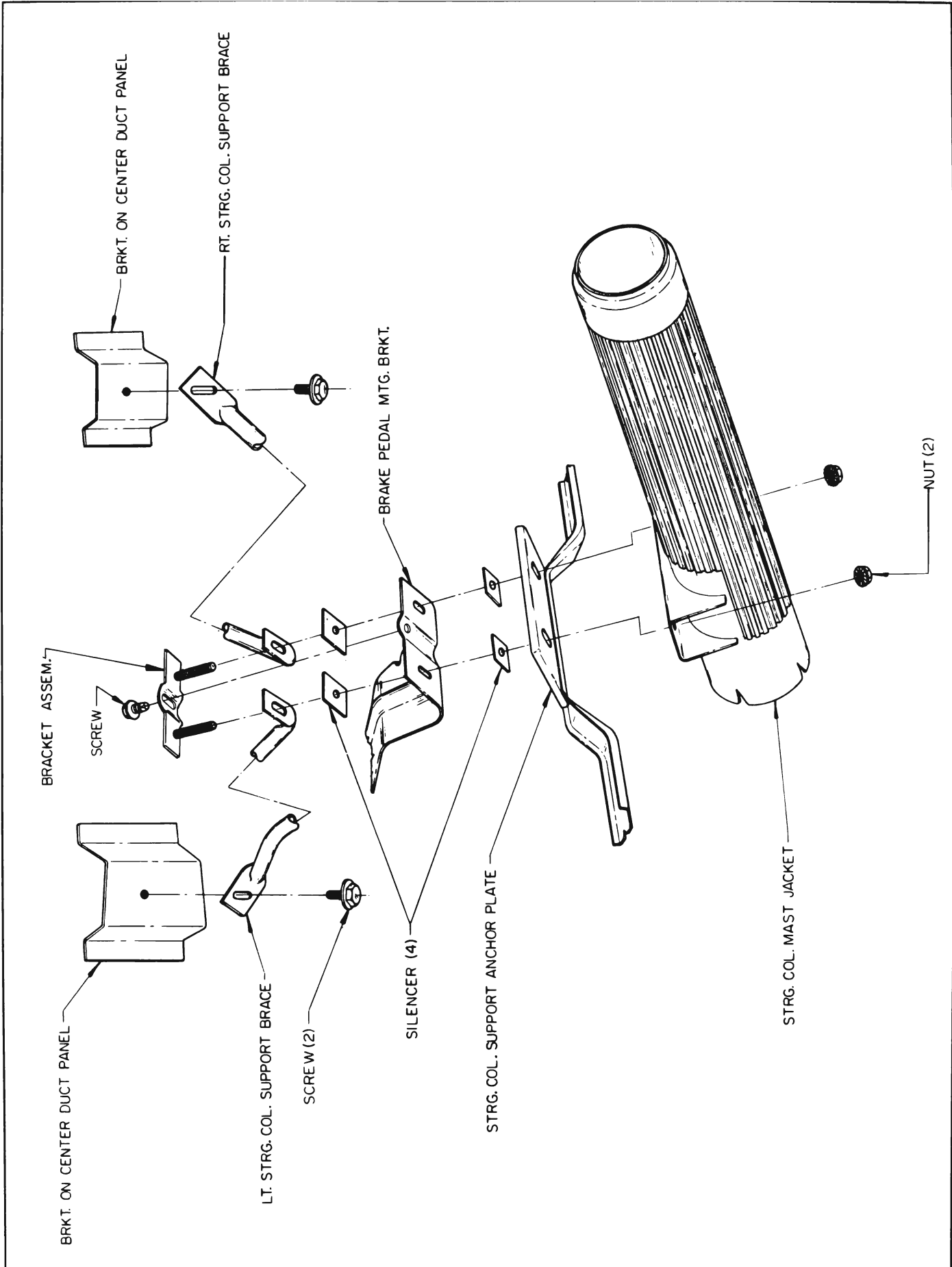

Figure 10-89—Steering Column Installation - Riviera

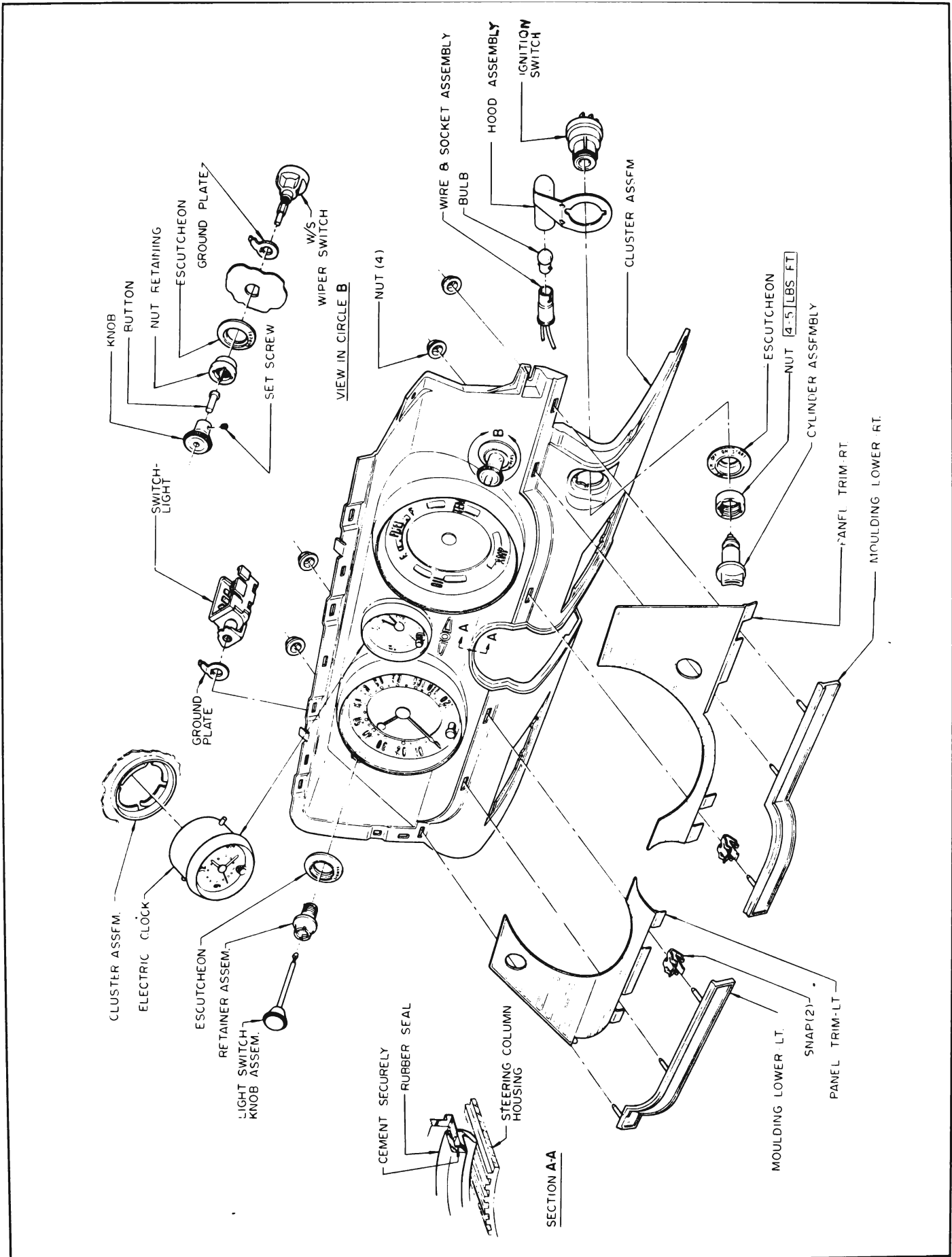

Figure 10-90—Instrument Cluster Assembly - Riviera

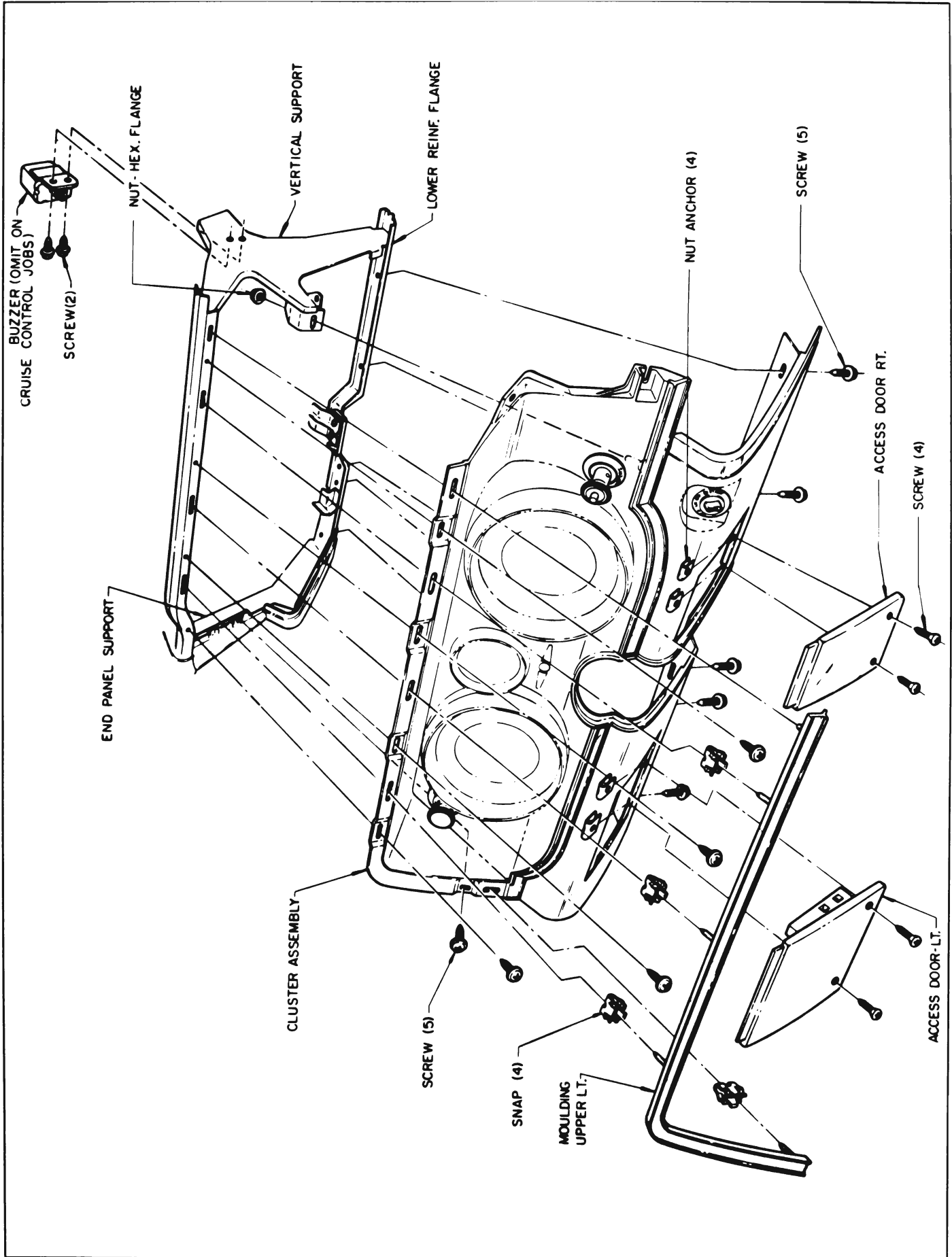

Figure 10-91—Instrument Cluster Installation - Riviera

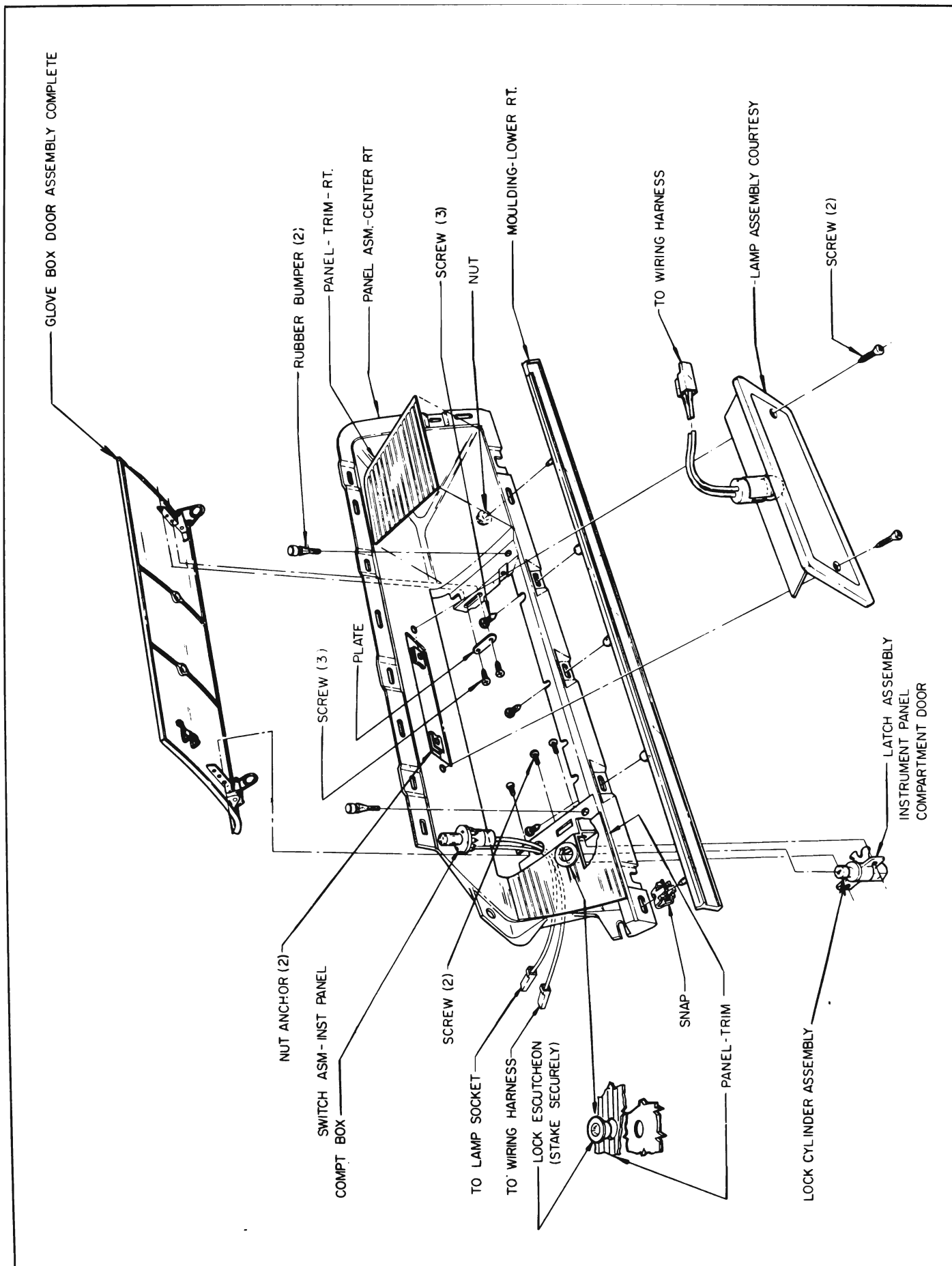

Figure 10-92—Right Center Instrument Panel Assembly - Riviera

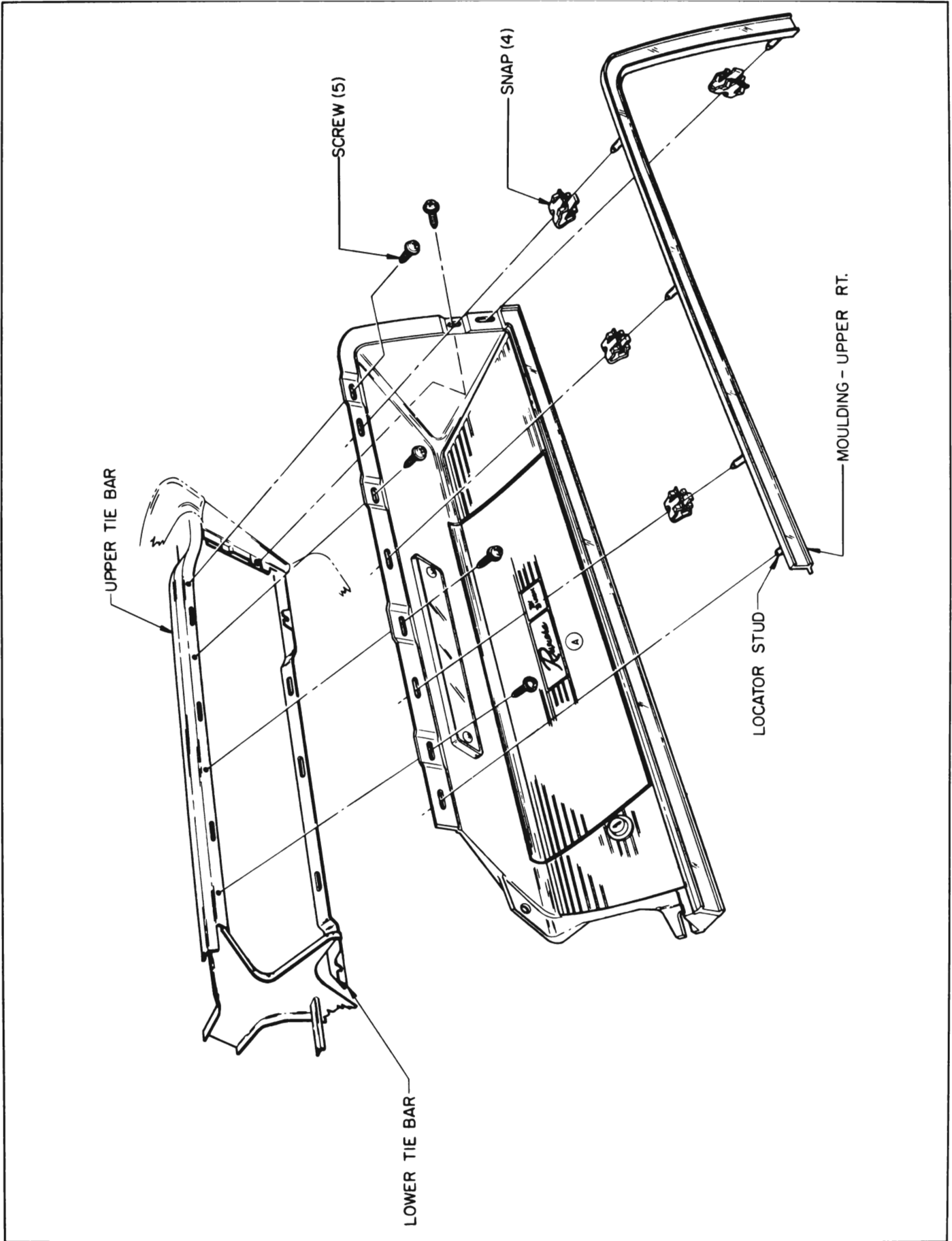

Figure 10-93—Right Center Instrument Panel Installation - Riviera

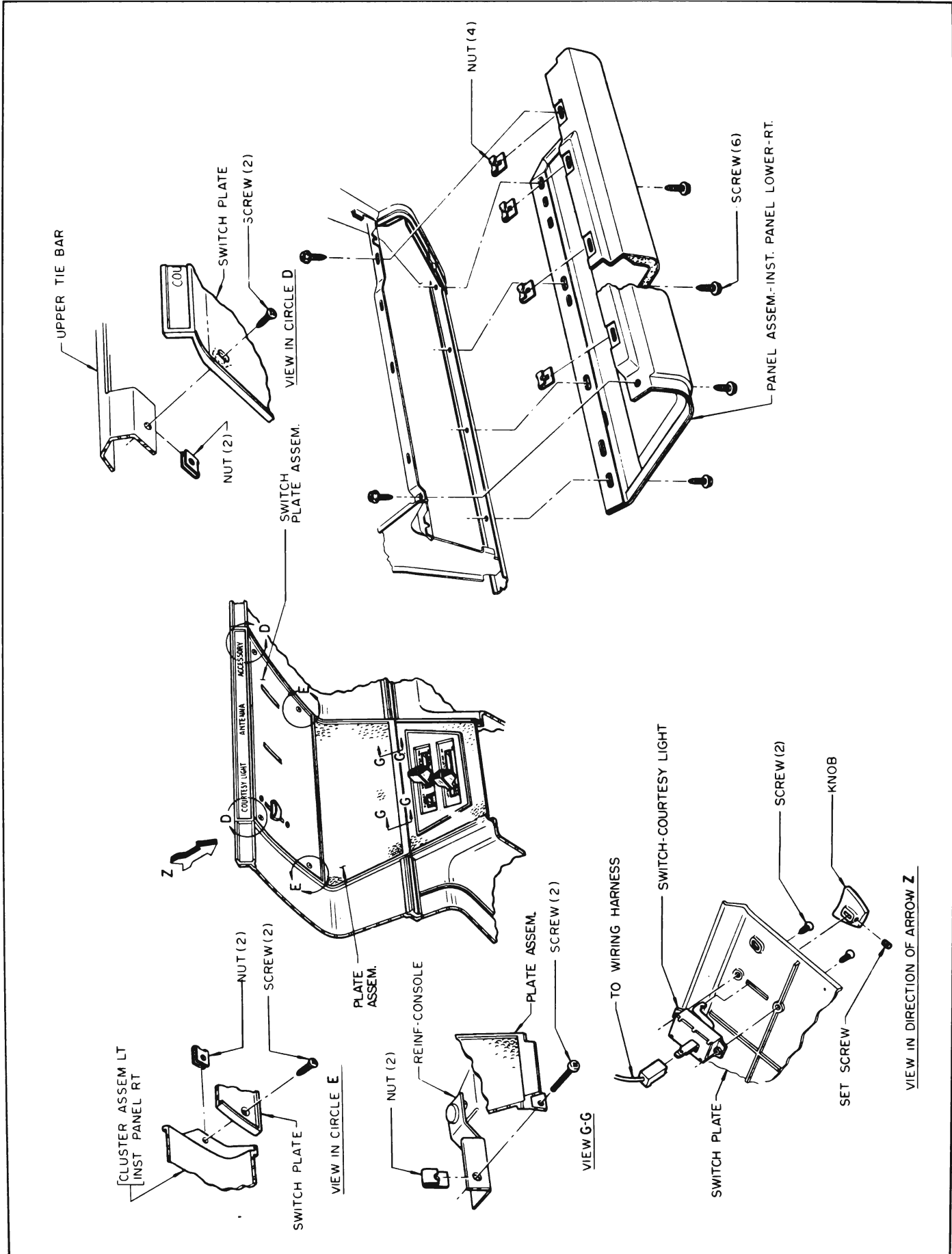

Figure 10-94—Center and Right Lower Instrument Panel Installation - Riviera

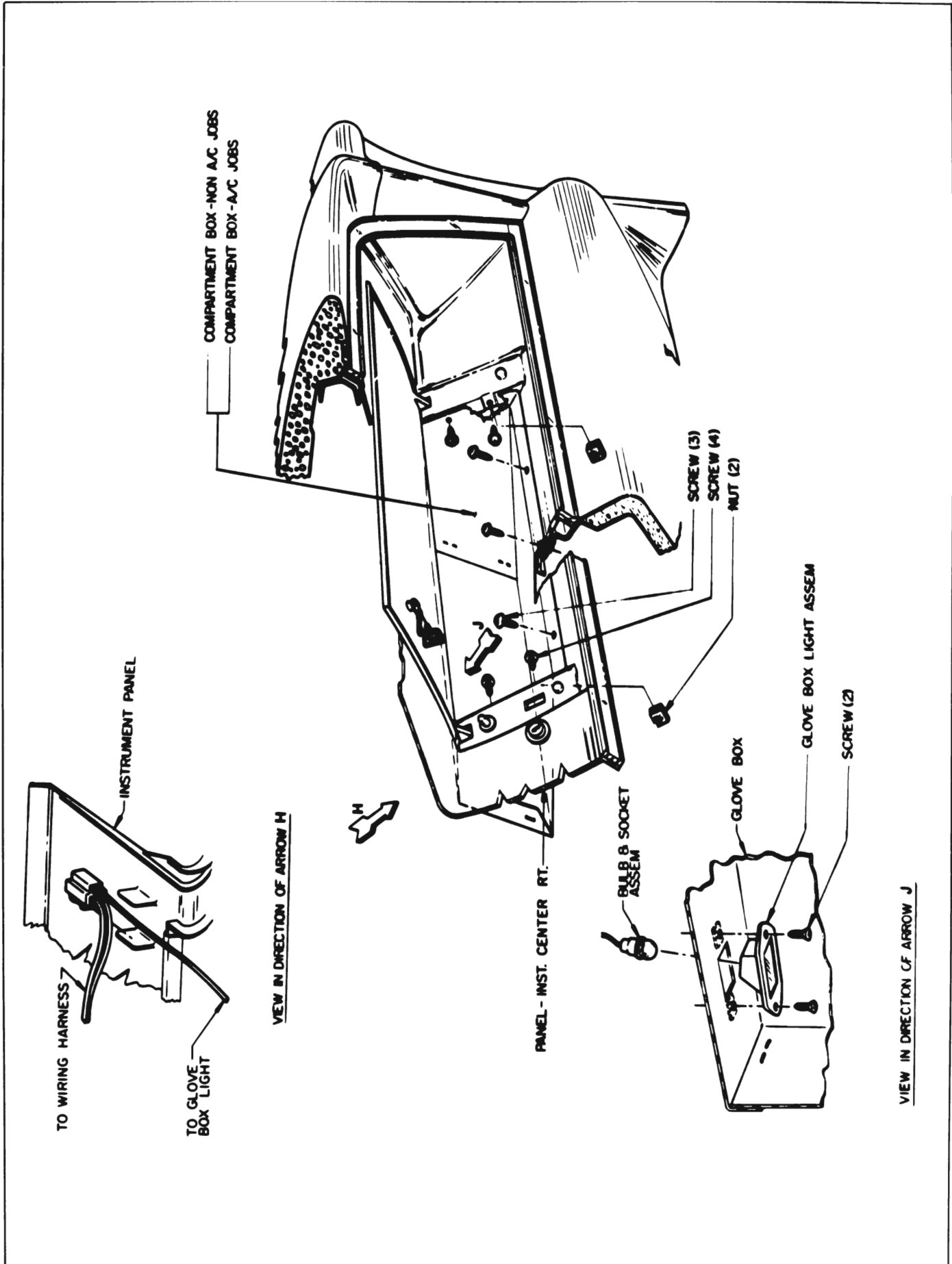

Figure 10-95—Glove Box Installation - Riviera

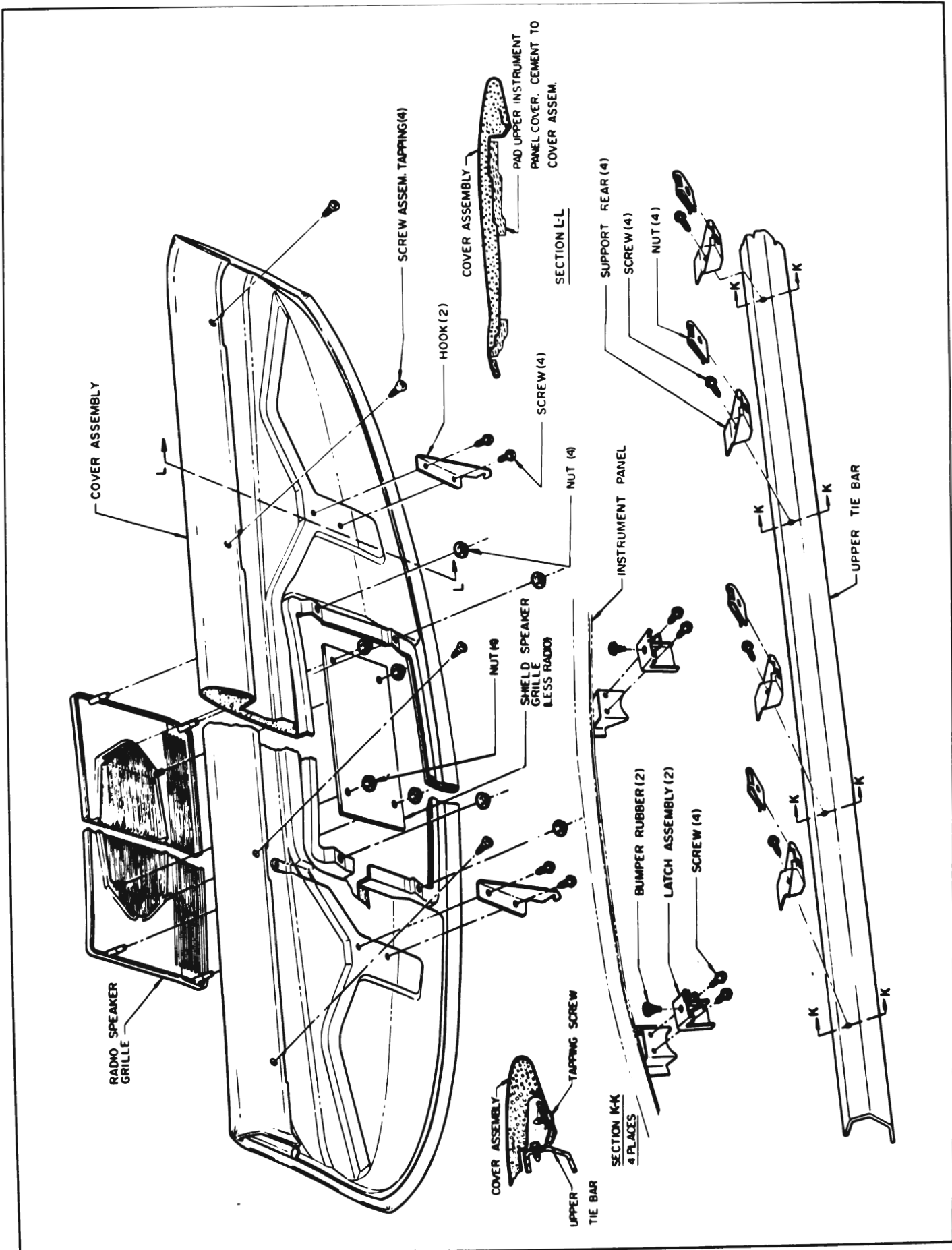

Figure 10-96—Instrument Panel Cover Assembly - Riviera

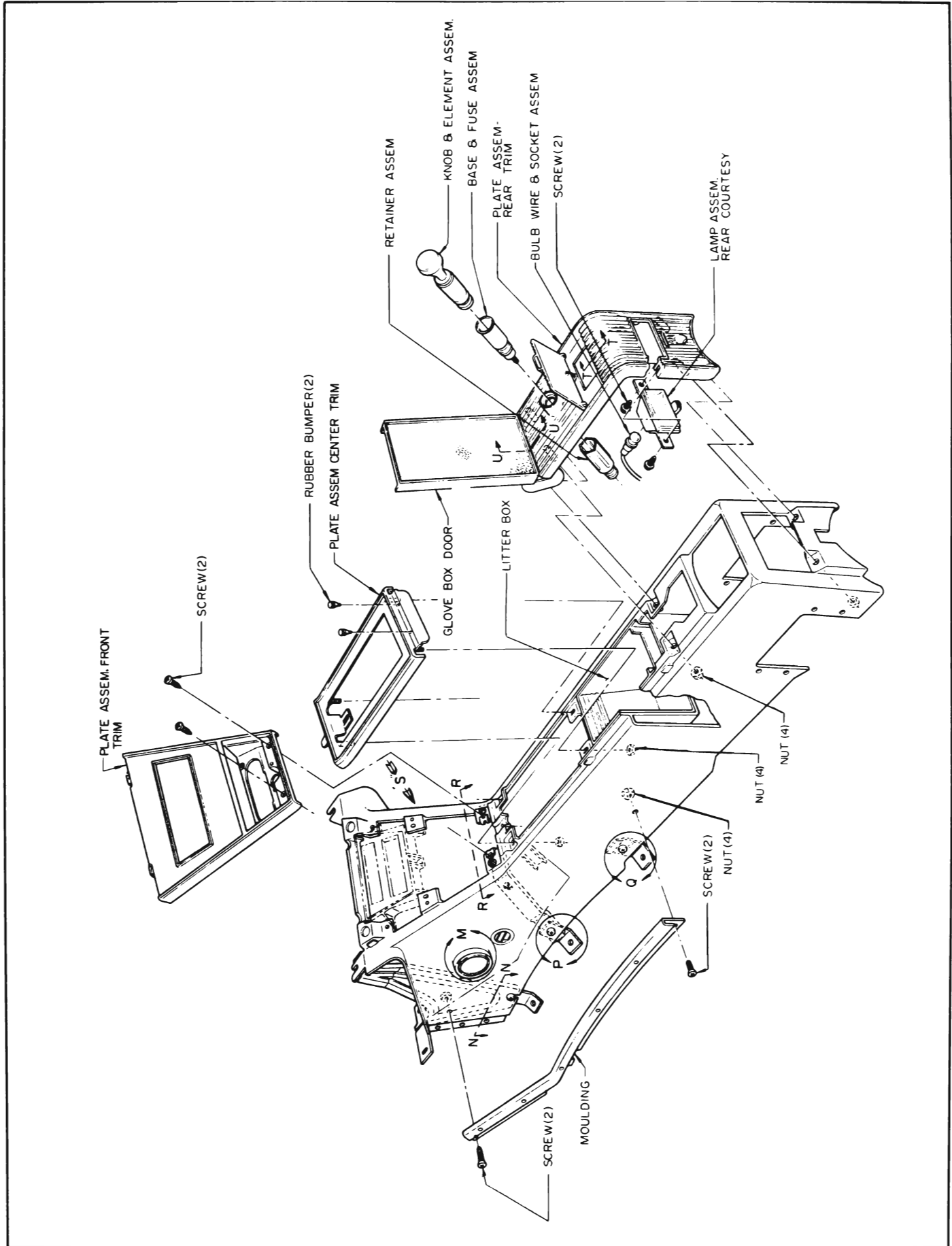

Figure 10-97—Console Assembly - Riviera

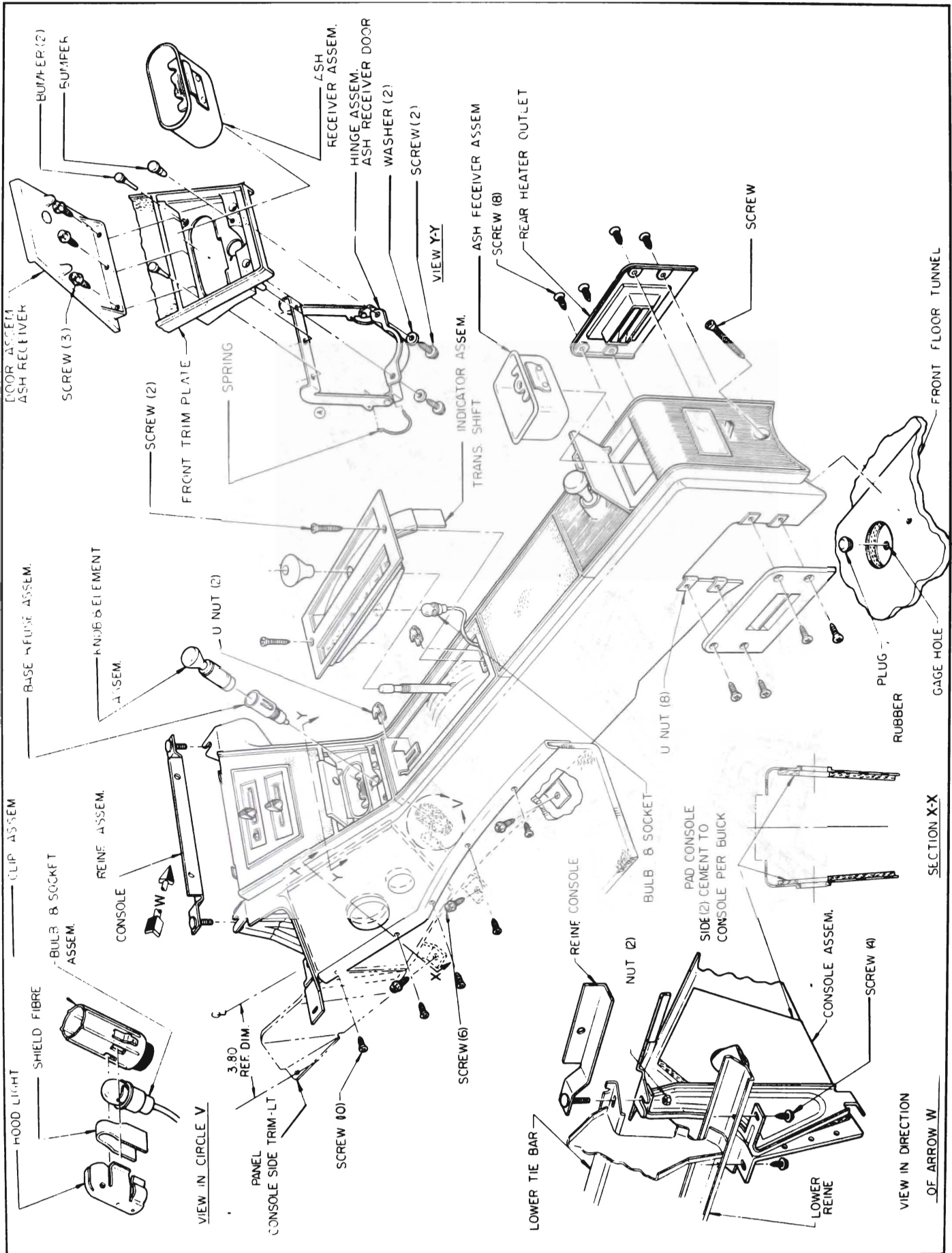

Figure 10-98—Console Installation - Riviera