

SECTION 10-C

GENERATING SYSTEM

CONTENTS OF SECTION 10-C

Paragraph	Subject	Page	Paragraph	Subject	Page
10-14	Description of Delcotron Generator	10-13	10-19	Inspecting Charging System	10-20
10-15	Generator Repair - on Bench	10-13	10-20	Cleaning Regulator Contacts	10-20
10-16	Description of Regulator	10-16	10-21	Delcotron Generator Tests	10-21
10-17	Operation of Charging System	10-17	10-22	Tailoring the Voltage Setting	10-21
10-18	Trouble-Shooting Charging System	10-18			

10-14 DESCRIPTION OF DELCOTRON GENERATOR

"Delcotron" * generators are continuous-output, diode-rectified alternating current generators. See Figure 10-7. The rotor is mounted on a ball bearing at the drive end, and a roller bearing at the slip ring end, and each bearing has a grease supply which eliminates the need for periodic lubrication. Two brushes are used to carry current through the two slip rings to the field coil which is mounted on the rotor. The brushes are extra long and under normal operating conditions will provide long periods of service.

The stator windings are assembled on the inside of a laminated core that forms part of the generator frame. See Figure 10-8.

* General Motors Trademark

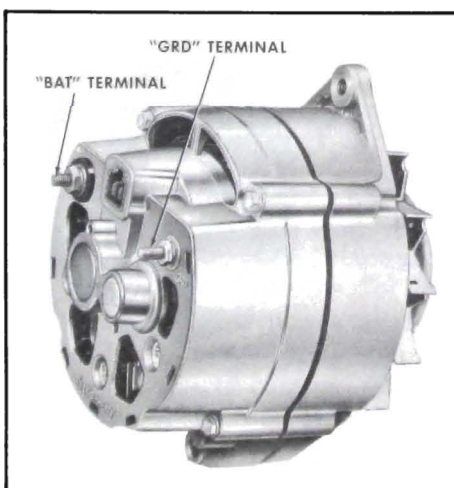

Figure 10-7—Delcotron Generator

Six rectifier diodes are mounted in the slip ring end frame and are connected to the stator windings. The six diodes act to change the generator AC voltages to DC voltage which appears at the "BAT" terminal of the generator.

IMPORTANT: Since the generator and regulator are designed for use on only one polarity system (negative ground), the following precautions must be observed when working on the charging circuit. Failure to observe these precautions will result in serious damage to the electrical equipment.

1. When installing a battery, always make absolutely sure the negative post is toward ground.
2. When connecting a booster battery make certain to connect the negative battery terminals together and the positive battery terminals together.
3. When connecting a charger to the battery, connect the charger positive lead to the battery positive terminal and the charger negative lead to the battery negative terminal.
4. Never operate the generator on open circuit. Make absolutely certain all connections in the circuit are secure.
5. Do not short across or ground any of the terminals on the generator or regulator.
6. Do not attempt to polarize the Delcotron generator.

10-15 GENERATOR REPAIR—ON BENCH

a. Disassembly

To disassemble the generator, take out the four thru-bolts, and separate the drive end frame and rotor assembly from the stator assembly by prying apart with a screwdriver at the stator slot. See Figure 10-8. A scribe mark will help locate the parts in the same position during assembly. The fit between stator and frame is not tight, and the two can be separated easily. Note that the separation is to be made between the stator frame and drive end frame. After disassembly, place a piece of tape over the slip ring end frame bearing to prevent entry of dirt and other foreign material.

To remove the drive end frame from the rotor, place the rotor in a vise and tighten only enough to permit removal of the shaft nut.

CAUTION: Avoid excessive tightening as this may cause distortion of the rotor. Remove the shaft nut, washer pulley, fan and the collar, and then separate the drive end frame from the rotor shaft.

If the rotor shaft has a hex socket in the drive end, use a 5/16" Allen wrench to hold the shaft during removal of the shaft nut.

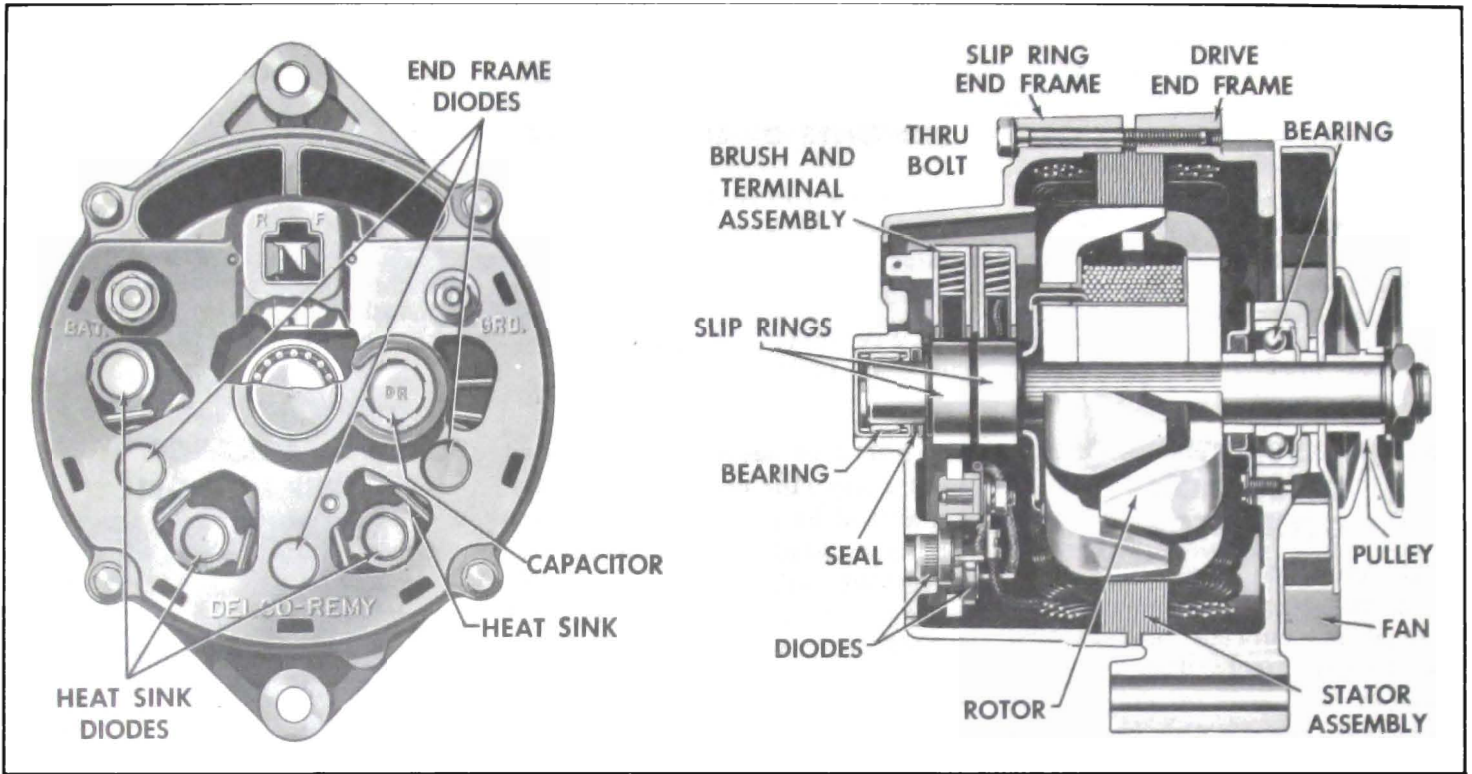

Figure 10-8—Sectional View

b. Rotor Checks

The rotor may be checked electrically for grounded, open or short circuited field coils. To check for grounds, connect a test lamp from either slip ring to the rotor shaft. See Figure 10-9. If the lamp lights, the field winding is grounded.

To check for opens, connect the test lamp to each slip ring. If the lamp fails to light, the winding is open.

The field winding is checked for short-circuits by connecting a battery and ammeter in series with the two slip rings. The field current at 12 volts and 80° F. should be between 1.9 and 2.3 amperes. (2.1 to 2.5 amperes with air conditioner). An ammeter reading above the specified value indicates shorted windings.

rated output, the trouble is in the stator or rectifying diodes.

c. Stator Checks

To check the stator windings, remove all three stator lead attaching nuts, and then separate the stator assembly from the end frame. The fit between stator frame and end frame is not tight, and the two can be separated easily.

The stator winding may be checked with a test lamp. If the

lamp lights when connected from any stator lead to the frame, the windings are grounded. If the lamp fails to light when successively connected between each pair of stator leads, the windings are open. See Figure 10-10.

A short circuit in the stator windings is difficult to locate without laboratory test equipment due to

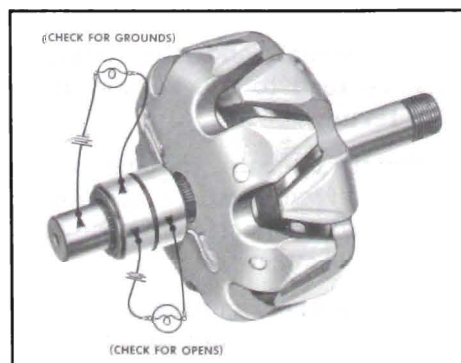

Figure 10-9—Checking Rotor for Opens or Grounds

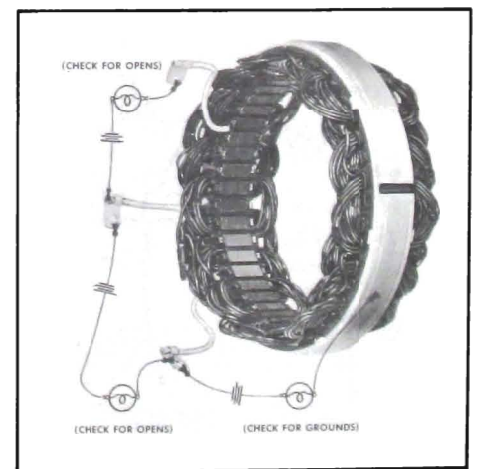

Figure 10-10—Checking Stator for Opens or Grounds

If the rotor is not defective but the generator failed to supply

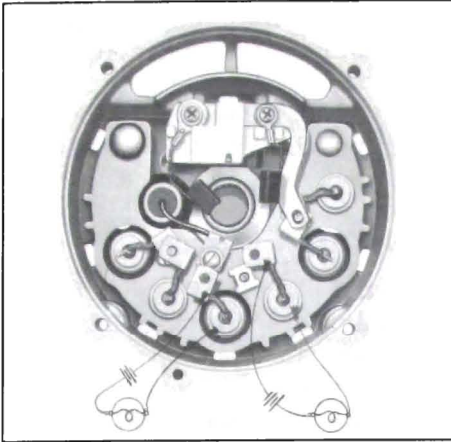

Figure 10-11—Checking Diodes for Opens or Shorts

the low resistance of the windings. However, if all other electrical checks are normal and the generator fails to supply rated output, shorted stator windings are indicated.

d. Diode Checks

Each diode should be checked electrically for a shorted or open condition using a test lamp of not more than 12 volts. **CAUTION:** Do not use a 110-volt test lamp to check diodes.

With the stator disconnected, connect the test lamp leads across each diode, first in one direction and then in the other. See Figure 10-11. If the lamp lights in both checks, or fails to light in both checks, the diode is defective. When checking a good diode, the lamp will light in only one of the two directions.

e. Diode Replacement

1. To remove a diode, place slip ring end frame in a vise so that Remover J-9717-1 bears against defective diode and Support J-9717-2 supports casting. Tighten vise to remove defective diode. See Figure 10-12.

2. To install a diode, place new diode in Installer J-9600-2. Place slip ring end frame in a vise so

that new diode is in position and Remover J-9717-1 supports casting. See Figure 10-13. Tighten vise to install new diode. **CAUTION:** Never attempt to remove or install a diode by striking it, as the shock may damage the other diodes.

f. Slip Ring Servicing

If the slip rings are dirty, they may be cleaned with No. 400 silicon carbide paper and finish polished with crocus cloth. Spin the rotor in a lathe, or otherwise spin the rotor, and hold the polishing cloth against the slip rings until they are clean. **CAUTION:** The rotor must be rotated in order that the slip rings will be cleaned evenly. Cleaning the slip rings by hand without spinning the rotor may result in flat spots on the slip rings, causing brush noise.

Slip rings which are rough or out of round should be trued in a lathe to .002 inch maximum indicator reading. Remove only enough material to make the rings smooth and round. Finish polish with crocus cloth and blow away all dust.

g. Bearing Replacement

The bearing in the drive end frame can be removed by detaching the retainer plate screws, and then pressing the bearing from

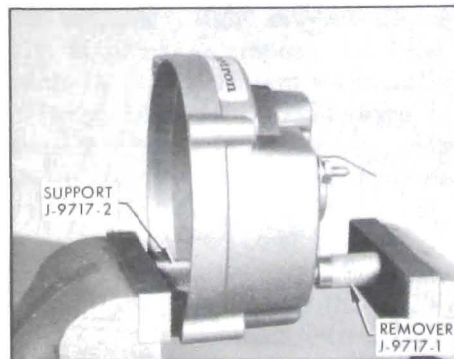

Figure 10-12—Removing a Diode

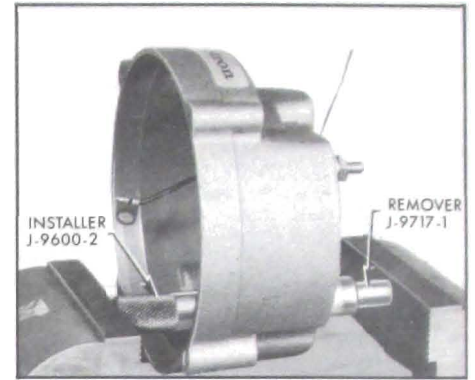

Figure 10-13—Installing a Diode

the end frame with Support J-9717-2.

To install a new bearing, press in with a tube or collar that just fits over the outer race. It is recommended that a new retainer plate be installed if the felt seal in the retainer plate is hardened or excessively worn.

The bearing in the slip ring end frame can be removed by pressing with a tube or collar that just fits inside the end frame housing. Press from the outside of the housing towards the inside using Support J-9717-2.

To install a new bearing, place a flat plate over the bearing and press in from the outside towards the inside of the frame until the bearing is flush with the outside of the end frame. Support the inside of the frame with a hollow cylinder to prevent breakage of the end frame. Use extreme care to avoid misalignment or otherwise placing undue stress on the bearing.

Saturate the felt seal with SAE 20 oil, and then reassemble the felt seal and steel retainer.

The bearings in the generator are permanently lubricated and require no lubrication during the life of the bearings. If a dry bearing is encountered, do not attempt to lubricate the bearing as improper lubricant or an

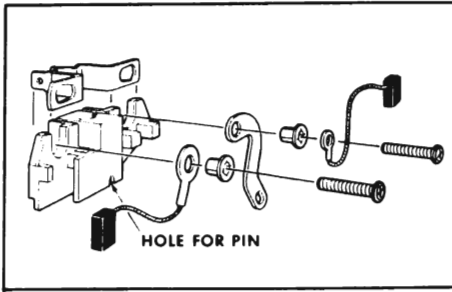

Figure 10-14—Assembling Brush Holder and Parts

excessive amount of lubricant may be thrown off and contaminate the inside of the Delcotron. Replace a dry, worn, or rough bearing with a new bearing which will be prepacked with the proper kind and amount of lubricant.

h. Brush Replacement

When the slip ring end frame assembly is separated from the rotor and drive end frame assembly, the brushes will fall down onto the shaft and come in contact with the lubricant. If the brushes are to be re-used, they must be thoroughly cleaned with a soft dry cloth. Also, the shaft must be thoroughly cleaned before reassembly.

The brush springs should be inspected for any evidence of

damage or corrosion. If there is any doubt as to the condition of the brush springs, they should be replaced.

To install new brushes, remove the brush holder assembly from the end frame by detaching the two brush holder assembly screws. Install the springs and brushes into the brush holder, and insert a straight wire or pin into the holes at the bottom of the holder to retain the brushes. Then attach the brush holder assembly onto the end frame, noting carefully the proper stack-up of parts as shown in Figure 10-14. Allow the straight wire to protrude through the hole in the end frame.

i. Heat Sink Replacement

The heat sink may be replaced by removing the "BAT" and "GRD" terminals from the end frame, and the screw attaching the condenser lead to the heat sink. During reassembly, note carefully the proper stack-up of parts as shown in Figure 10-15.

j. Reassembly

Reassembly is the reverse of disassembly. See Figure 10-16

for connection of internal leads. Remember when assembling the pulley to secure the rotor in a vise only tight enough to permit tightening the shaft nut to 50-60 ft. lbs. If excessive pressure is applied against the rotor, the assembly may become distorted.

To install the slip ring end frame assembly to the rotor and drive end frame assembly, remove the tape over the bearing and shaft, and make sure the shaft is perfectly clean.

Insert a straight wire as previously mentioned through the holes in the brush holder and end frame to retain the brushes in the holder. Then withdraw the wire after the generator has been completely assembled. The brushes will then drop onto the slip rings.

10-16 DESCRIPTION OF REGULATOR

The regulator assembly is made up of a double contact voltage regulator unit and a field relay. See Figure 10-17. The voltage regulator unit operates to limit the generator voltage to a preset

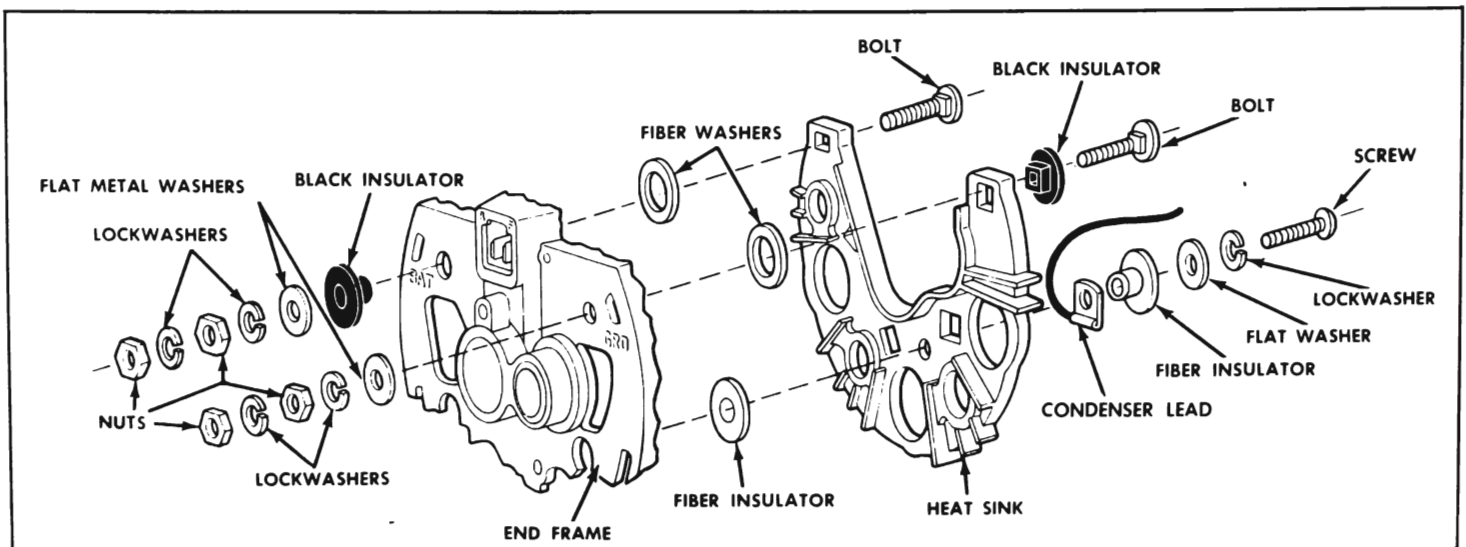

Figure 10-15—Assembling Heat Sink and Parts

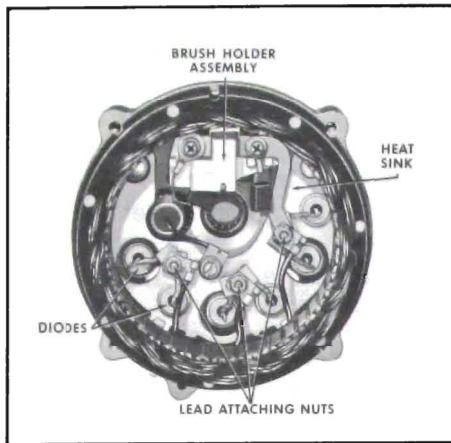

Figure 10-16—Internal Leads

maximum. The field relay connects and disconnects the voltage regulator and generator field directly to the battery. The indicator lamp lights at about 1/2 brightness when the ignition switch is turned on; when the engine is started, the indicator light goes out. If the indicator light ever comes on with the engine running, trouble in the charging system is indicated.

10-17 OPERATION OF CHARGING SYSTEM

Before the generator will put out any current, the rotor field must be energized. The rotor poles have practically no residual magnetism, so unless current is

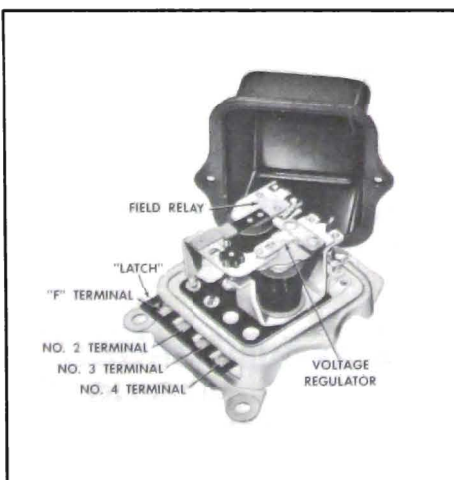

Figure 10-17—Regulator

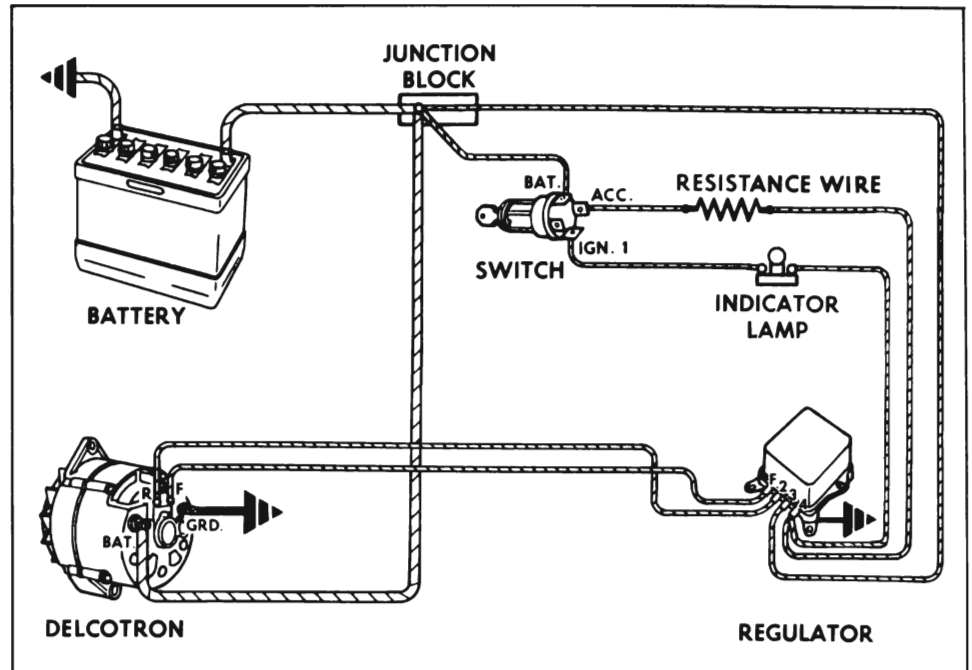

Figure 10-18—Delcotron Generator Wiring

supplied to the field from the battery, there can be no output from the generator.

When the ignition switch is turned on, current flows immediately through the field to ground inside the generator. Before the engine is started, the path of the field current is from the junction block, to the "BAT" terminal of the ignition switch, through the switch to both the "IGN" and the "ACC" terminal. From the "IGN" terminal, current flows through the generator indicator light in the instrument cluster (causing it to light), to the "4" terminal of the regulator. See Figure 10-22.

The indicator light circuit allows only about 1/4 ampere to flow, which is not sufficient to initially energize the field. Therefore, a parallel circuit is necessary; this circuit allows about 3/4 ampere to flow from the "ACC" terminal, through the large cowl connector, through a 10 ohm resistance wire to the "4" terminal of the regulator. The combined current of about one ampere flows through the lower contacts of the voltage

regulator (held closed by the spring), out the "F" terminal of the regulator, in the "F" terminal of the generator, through the brush and slip ring to ground. See Figure 10-19.

When the engine is started, the stator windings immediately put out a voltage. This voltage is conducted from one phase of the stator, out the "R" terminal of the generator, in the "2" terminal of the regulator, through the field relay windings to ground. Even a low voltage at the field relay is sufficient to overcome the spring tension of the armature, thereby closing the field relay contacts.

The instant the field relay closes, the field current is supplied directly from the battery instead of through the ignition switch and resistance wire. The field current then comes from the battery, into the "3" terminal of the regulator through the field relay, and on through the field as before. This allows the same voltage to be present at the "4" terminal as at the ignition switch, thereby causing current to stop

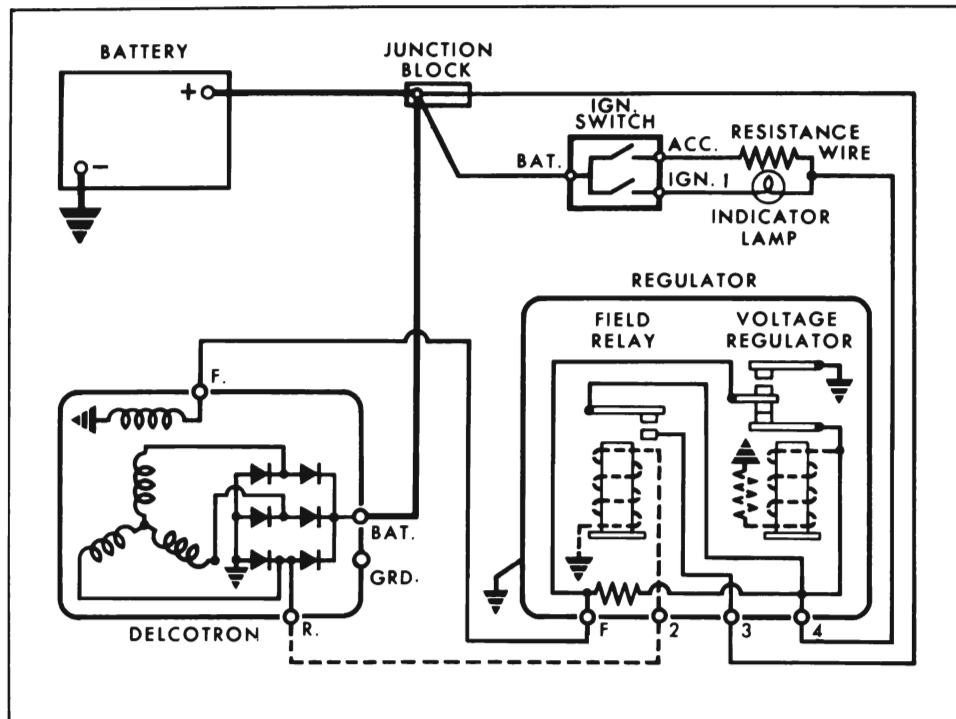

Figure 10-19—Delcotron Generator Wiring Circuit Diagram

flowing through either connecting wire and causing the generator indicator light to go out. The field relay, therefore, has a dual function; it not only completes the circuit between the battery and the field, but also acts as an indicator light relay.

The voltage regulator armature has two contact points which are over and under stationary contact points. When the voltage regulator unit is not operating, the tension of a spiral spring holds the armature away from the core so that the lower set of contacts is closed. See Figure 10-19.

Generator output depends on two variables: Speed and field strength. Only the field strength can be controlled, however. Voltage regulator operation varies according to operating conditions of the car electrical system. There are several stages of voltage regulator operation as follows:

a. Lower Contacts Closed

When the accessories and/or battery need a great deal of current,

but the engine speed is low, the lower contacts will remain tightly closed to allow full field current of approximately 2 amperes. The accessory load not supplied from the generator will be supplied from the battery.

b. Lower Contacts Vibrating

When the accessory load or battery needs are somewhat less, or the engine speed is a little higher, 2 amperes field current would cause too much generator output. Therefore, the lower voltage regulator contact will vibrate to reduce field current. When the contacts are open, the entire field current must flow through the resistor, which limits current to about 3/4 ampere. While the lower contacts are vibrating, then, field current will be somewhere between 2 amperes and 3/4 ampere, depending on the rate of vibration.

c. Both Contacts Open

When the balance of the accessory load and the engine speed is such

that approximately 3/4 ampere field current will provide exactly the needed generator output, the voltage regulator armature will "float" with neither set of contacts touching. Any change in speed or load will upset the balance, however, causing the regulator contacts to again vibrate.

d. Upper Contacts Vibrating

When the combined accessory and battery load is low and the engine speed is high, very little field current is required to provide the needed generator output. The voltage in the charging circuit will rise between .1 and .3 volt and the regulator armature will be drawn farther down to operate on the upper set of contacts. When the contacts are open, field current will be about 3/4 ampere; when the contacts are closed, the upper armature grounds the current from the resistor and field current is zero. See Figure 10-19. While the upper contacts are vibrating, then, field current will be somewhere between 3/4 ampere and zero, depending on the rate of vibration.

The regulator does not contain a cutout relay unit. The rectifier diodes act as one-way check valves to prevent the battery from discharging back through the generator, thereby making a cutout relay unnecessary.

The regulator does not contain a current limiting unit because an alternating current generator acts as its own current regulator.

10-18 TROUBLE-SHOOTING CHARGING SYSTEM

SPECIAL PRECAUTIONS: Alternating current charging system circuits are completely different

from direct current charging system circuits. Therefore, none of the troubleshooting checks used for direct current systems can be used. The diodes may be burned out if you do not observe the following precautions:

1. Never arc terminals. Never short between terminals on the generator or regulator; never arc any terminal to ground. The field has no residual magnetism and therefore cannot be polarized; any attempt to do so may cause damage.

2. Always observe polarity. Use extreme caution before installing a battery, connecting a fast charger or connecting a booster battery to insure that the ground polarity is matched to the ground polarity of the generator and regulator. For example, if a battery is accidentally installed in reverse, the diodes in the generator may be burned out and the wiring harness between the generator and battery will be burned. The generator charging system is a negative ground system, just as Buick's charging systems have always been.

3. Always disconnect battery before doing any work on the generator or regulator.

Complaints on operation of the charging system generally fall into one of the following classifications. Go through steps listing possible troubles in order until the trouble is found.

a. Battery Runs Down

1. Check generator belt tension. Belt tension as measured with Gauge J-7316 should be 80 pounds with a single belt or 110 pounds with a double belt.

2. Check battery condition. Light load test battery to see if battery is actually low (par. 10-9). If

low, quick-charge battery and retest to see if battery is defective. A battery which is sulphated or one with an intermittent internal "open" will remain in an under-charged condition. Replace a defective battery.

3. Check for short or ground. To check complete car electrical system for a short or ground, disconnect ground cable from battery and connect a voltmeter between ground cable and battery post. Make sure all lights and accessories are off and that clock is wound. If voltmeter reads battery voltage, there is a short or ground which must be traced and eliminated; any reading less than battery voltage indicates current leakage so slight that nothing need be done about it.

4. Check generator output. Hook-up test instruments and check current output of generator as described in Delcotron Generator Tests paragraph. If output is low, remove generator for disassembly, test and repair. If generator output tests okay, leave test instruments hooked up and proceed with Step 5.

5. Check voltage regulator setting, as described in Delcotron Generator Tests paragraph. If voltage fluctuates, look for loose or corroded connections in the charging system; if none, clean voltage contacts as described in paragraph on Cleaning Regulator Contacts. If voltage setting is low, adjust to specifications shown in Figure 10-21.

If voltage setting is within the specified limits, but battery checked low in Step 2, raise voltage setting slightly as described in paragraph on Tailoring The Voltage Setting.

b. Battery Uses Too Much Water

1. Check battery condition. Light load test battery to see if there is

a shorted cell (par. 10-9). A battery having a shorted cell will use water excessively. Replace a defective battery.

2. Check voltage regulator setting, as described in Delcotron Tests paragraph. If voltage setting is high, adjust to specifications shown in Figure 10-21. If voltage setting is within limits, lower voltage setting slightly as described in paragraph on Tailoring Voltage Setting.

c. Faulty Indicator Light Operation

There are three conditions of indicator light operation which indicate trouble in the charging system.

1. Indicator light on - ignition off. This is caused by a shorted positive diode. There will be a continuous drain on the battery through the generator. Remove generator for disassembly, test and repair.

2. Indicator light off - ignition on. Before the engine is started, the indicator light should glow at about 1/2 the brightness of the oil pressure light. If the light does not come on, check for either a burned out bulb or an open in the indicator light circuit. A shorted diode as described in Step 1 will also cause the indicator light to go off when the ignition is switched on.

3. Indicator light on - engine running. This can be caused by a loose or missing belt, a defective field relay, or a defective generator. Determine source of trouble as follows:

(a) Check generator belt tension.

(b) Check voltage at field relay coil by connecting a voltmeter from regulator "2" terminal to ground. If voltmeter reading is above 5 volts and the indicator light fails to go out, field relay is defective. Check and replace,

if necessary. If voltmeter reading is below 5 volts, field relay is probably okay so proceed with Step c.

(c) Check voltage at generator field by connecting a voltmeter from generator "F" terminal to ground. If voltmeter reading is below 5 volts, check for a resistance or open in the circuit that should supply the initial field current. See Figure 10-23.

If voltmeter reading at "F" terminal is above 5 volts but voltage output from "R" terminal is low, trouble is in the generator. Hook-up test instruments and check current output of generator as described in Delcotron Generator Tests paragraph. If output is low, remove generator for disassembly, test and repair.

10-19 INSPECTING CHARGING SYSTEM

At regular intervals, inspect the terminals for corrosion and loose connections, and the wiring for frayed insulation. Check the mounting bolts for tightness and the belt for alignment, proper tension and wear. Belt tension should be adjusted to 80 pounds with a single belt or 110 pounds with a double belt as measured with Gauge J-7316. When tightening belt tension, apply pressure against the stator laminations between the end frames, and not against either end frame.

Noise from a Delcotron generator may be caused by worn or dirty bearings, loose mounting bolts, a loose drive pulley, a defective diode, or a defective stator.

10-20 CLEANING REGULATOR CONTACTS

The voltage regulator contacts should not be cleaned unless the electrical performance indicates

it is necessary. A sooty or discolored condition of the contacts is normal after a relatively short period of operation and is not an indication that cleaning is necessary. However, if the voltage fluctuates as evidenced by an unsteady voltmeter reading when checking the voltage setting, the contacts may have excessive resistance or be sticking and they, therefore, should be cleaned.

CAUTION: Before cleaning contacts, make sure the unsteady voltage is not being caused by loose connections or high resistance elsewhere in the system.

The contacts on the voltage regulator unit are of a soft material and must not be cleaned with a file. A strip of No. 400 silicon carbide paper or equivalent folded over and then pulled back and forth between the contacts is recommended as a satisfactory method of cleaning. After cleaning, the contacts should be washed with trichlorethylene or alcohol to remove any residue. If the voltage

control has not improved, repeat the cleaning and washing process.

To clean the field relay contacts, use a thin fine-cut, flat file. Remove only enough material to clean the points. **CAUTION:** Never use emery cloth or sandpaper to clean contact points.

10-21 DELCOTRON GENERATOR TESTS

a. Test Current Output

1. Check belt tension. Adjust to 80 lbs. with a single belt or 110 lbs. with a double belt as measured with Gauge J-7316.
2. Disconnect ground cable from battery.
3. Connect ammeter between generator "BAT" terminal and disconnected lead as shown in Figure 10-20.
4. Connect a tachometer from distributor terminal of coil to ground.

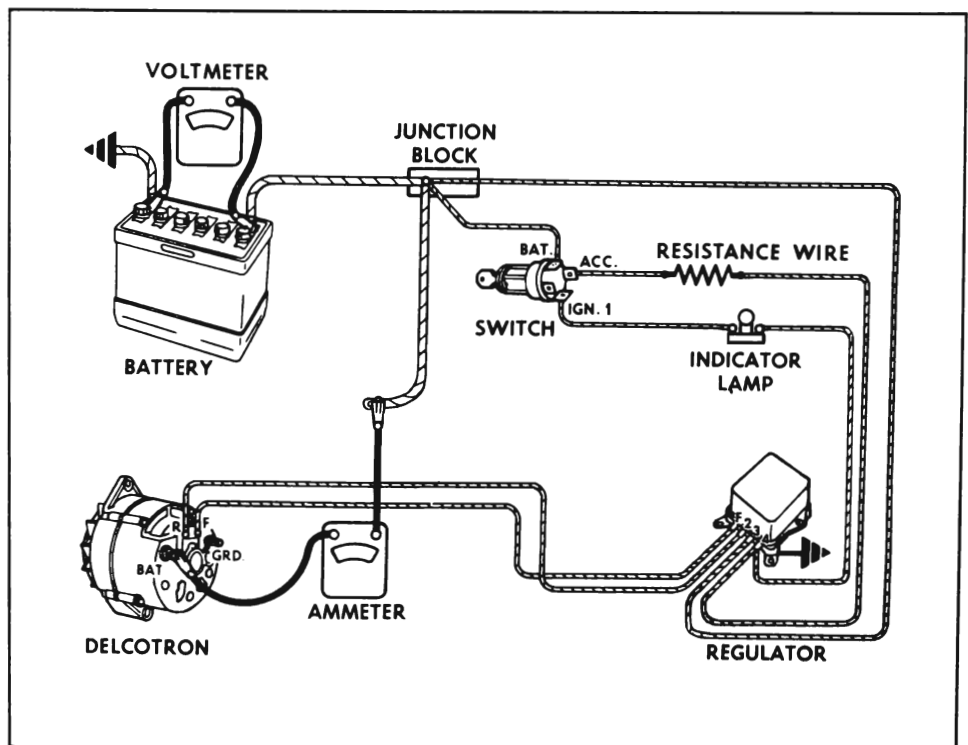

Figure 10-20—Delcotron Generator Tests

Air Temperature at Regulator	85°	105°	125°	145°	165°
Voltage Setting	13.8-14.6	13.7-14.5	13.5-14.3	13.4-14.2	13.2-14.0

Figure 10-21—Voltage Regulator Settings

5. Reconnect battery ground cable. Connect a voltmeter across battery.

6. Turn on all possible accessory load. Apply parking brake firmly. Start engine. Adjust engine idle to exactly 500 RPM in Drive. At this engine speed, generator output should be 10 amperes or over. Shift transmission to Park. Increase engine speed to exactly 1500 RPM; output should be 30 amperes or over. Shut off engine. Turn off all accessories.

7. If output is low in either of the above tests, try supplying field directly to cause full generator output. Unplug connector from generator. Connect a jumper such as Adaptor J-21053 from generator "F" terminal to "BAT" terminal. Retest as described in Step 6. If output is still low, generator is faulty and must be removed for bench tests and repairs.

8. If output (using field jumper) is now okay, trouble is in the regulator or wiring harness. Clean and test regulator. Check all wiring connections.

9. Remove field jumper and re-install vehicle field connector.

b. Test and Adjust Voltage Regulator Setting

1. Test current output as described above. See Figure 10-20. Leave all test instruments in place, but make sure field jumper is removed, if used.

2. Install a thermometer such as Gauge J-8529 near regulator.

3. Run engine at approximately 1500 RPM for 15 minutes. Make sure all electrical load except ignition is turned off.

4. Check ammeter reading. For an accurate voltage setting check, ammeter must read between 3 and 10 amperes. (If ammeter reading is still high after 15 minutes, it may be necessary to substitute a fully charged battery.) Momentarily increase engine speed to approximately 2000 RPM and read voltmeter and thermometer. See Figure 10-21 to determine if upper voltage regulator setting is within limits for the existing temperature. If setting is within limits and battery condition has been satisfactory, voltage setting should not be disturbed.

5. If voltage regulator setting is out of limits, make a note of change required to put voltage in middle of specified range. Remove regulator cover, lifting cover carefully straight up. CAUTION: If the cover touches either regulator unit, the resulting arc may ruin the regulator assembly.

6. With cover off, voltage reading will change considerably. Starting with the changed voltage reading, increase or decrease voltage (the amount determined in Step 5) as shown in Figure 10-22.

CAUTION: Always make final adjustment by increasing spring tension to assure contact between screw head and spring support.

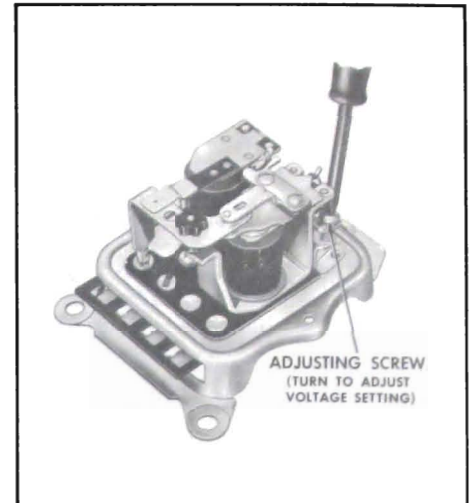

Figure 10-22—Adjusting Voltage Regulator Setting

7. After making an adjustment, replace cover carefully and re-check voltage setting of regulator.

10-22 TAILORING THE VOLTAGE SETTING

It is important to remember that the voltage setting for one type of operating condition may not be satisfactory for a different type of operating condition. Vehicle underhood temperatures, operating speeds, and nighttime service all are factors which help determine the proper voltage setting. The proper setting is attained when the battery remains fully charged with a minimum use of water.

If not circuit defects are found, yet the battery is continually undercharged, raise the setting by .3 volt, and then check for an improved battery condition over a service period of reasonable length. If the battery is continually overcharged, lower the setting by .3 volt, and then check for an improved battery condition. However, never adjust the voltage setting out of the limits specified in Figure 10-21.

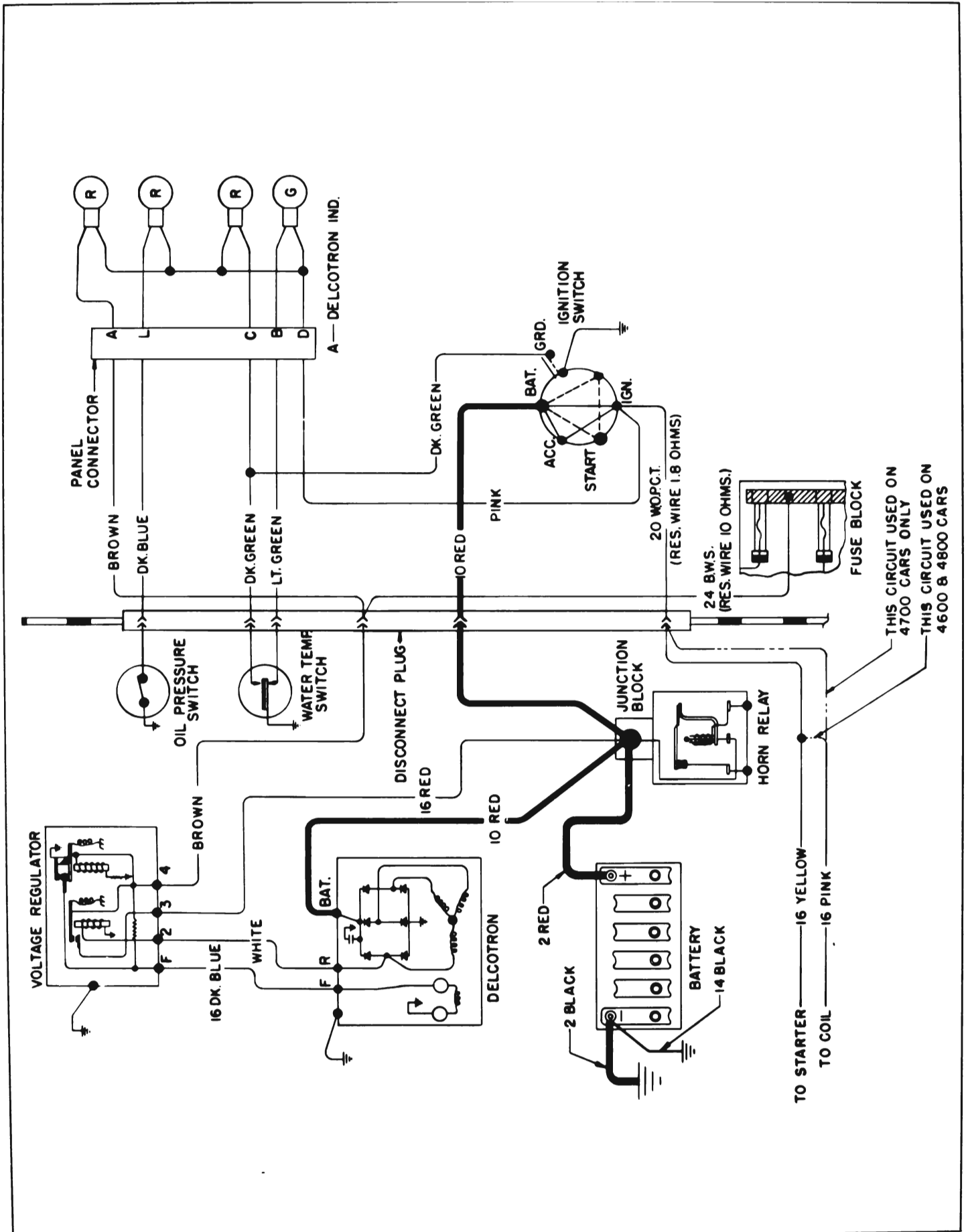

Figure 10-23—Delcotron Generator Wiring Diagram