

# GROUP 7 CHASSIS SUSPENSION

## SECTIONS IN GROUP 7

Section	Subject	Page	Section	Subject	Page
7-A	Specifications and Description of Chassis Suspension . . . . .	7-1	7-C	Service, Adjustment and Replacement Procedures - Chassis Suspension . . . . .	7-12
7-B	Trouble Diagnosis, Chassis Suspension . . . . .	7-5			

## SECTION 7-A SPECIFICATIONS AND DESCRIPTION OF CHASSIS SUSPENSION

### CONTENTS OF SECTION 7-A

Paragraph	Subject	Page
7-1	Specifications . . . . .	7-1
7-2	Description . . . . .	7-2

## 7-1 CHASSIS SUSPENSION SPECIFICATIONS

### a. Tightening Specifications

Use a reliable torque wrench to tighten the parts listed, to insure proper tightness without straining or distorting parts. These specifications are for clean and lightly lubricated threads only, dry or dirty threads produce increased friction which prevents accurate measurement of tightness.

	Location	Thread Size	Torque Ft. Lbs.
Link & Nut	Stabilizer Link . . . . .	5/16-24	5-10
Bolt	Front Shock to Upper Support . . . . .	5/16-24	15-25
Bolt	Front Shock to Lower Control Arm . . . . .	5/16-24	15-25
Bolt & Nut	Stabilizer Shaft Bracket to Underbody . . . . .	3/8 -24	25-40
Bolt & Nut	Tie-Rod Adjuster . . . . .	3/8 -24	20-25
Bolt & Nut	Brake & Arm to Knuckle . . . . .	7/16-20	55-60
Nut	Ball Joint to Knuckle . . . . .	7/16-20	35-60
Bolt & Nut	Upper Control Arm Shaft to Front Cross Member . . . . .	7/16-20	60-85
Bolt	Rear Lower Control Arm Bracket to Underbody . . . . .	7/16-14	45-60
Bolt & Nut	Rear Shock Upper Pivot . . . . .	7/16-20	45-60
Nut	Rear Shock Lower Pivot . . . . .	1/2 -20	30-45
Bolt & Nut	Rear Lower Control Arm to Bracket . . . . .	9/16-18	85-110
Bolt & Nut	Rear Lower Control Arm to Axle Housing . . . . .	9/16-18	85-110
Bolt & Nut	Rear Upper Control Arm to Body Bracket . . . . .	9/16-18	85-110
Bolt & Nut	Rear Upper Control Arm to Differential Carrier . . . . .	9/16-18	85-110
Nut	Front Wheel Spindle . . . . .	5/8 -24	(Par. 7-11)
Nut	Wheel Attaching . . . . .	7/16-20	55-75
Bolt or			
Bolt & Nut	Isolation Mount to Underbody . . . . .	1/2 -13	65-90
Ball Joint	Ball Joint to Control Arm . . . . .	SEE TEXT	
Bushing	Upper & Lower Control Arms to Shafts . . . . .	SEE TEXT	

**b. Wheels And Tires**

Items	All Series
Wheel Type . . . . .	Demountable Steel Disc
Rim Type . . . . .	Drop Center
Rim Size . . . . .	13 x 4.50
Tire Type . . . . .	Tubeless 6.50 x 13
Tire Size	
Optional Tire Size . . . . .	6.00 x 15, 7.00 x 13
Tire Inflation Pressure (Cold) . . . . .	See Paragraph 1-2
Wheel Attaching Nuts	7/16-20 Torqued to 55-70 ft. lbs. Left Side has Left Hand Threads

**c. Shock Absorbers**

Items	All Series
Shock Absorber	
Make and Type -- Front . . . . .	Delco, Double Direct-Acting
Make and Type -- Rear . . . . .	Delco, Double Direct-Acting

**d. Springs**

Items	All Series
Spring Trim Dimensions . . . . .	See Paragraph 7-15
Spring Type . . . . .	Coil Front and Rear

**e. Stabilizers**

Items	All Series
All Models except Station Wagons and Police Options . . . . .	13/16" diameter
Station Wagons . . . . .	7/8" diameter
Police Option . . . . .	15/16" diameter

**7-2 DESCRIPTION OF WHEEL SUSPENSION**

**a. Front Suspension**

The entire front suspension system is attached to the underbody by three isolation mounts and is of the ball joint, independent type.

Each wheel is independently connected, thru tapered roller bearings, to the front cross bar by a steering knuckle, ball and socket assemblies, and upper and lower control arm assemblies. The upper and lower arms are so positioned and proportioned in length that they allow each knuckle and wheel to move through a controlled arc only. The

front wheels are held in proper relation to each other by means of two tie rods which connect to steering arms on the steering knuckles and to the intermediate rod. See Figure 7-1.

A coil-type chassis spring is mounted between the front spring housing, integral with the front suspension cross member and the lower control arm. Ride control is provided by a double direct acting shock absorber mounted through the coil spring and between the lower control arm and the upper control arm shaft bracket.

A rubber bumper is mounted on the outer end of each lower control arm to limit travel of the

arm during compression of chassis spring. A similar rubber bumper is mounted on the ends of the front cross member, under control arm, to limit travel of arm during rebound of chassis spring.

Side roll of the front end of chassis is controlled by a spring steel stabilizer shaft. The shaft is mounted in rubber bushings supported in brackets attached to the underbody. The ends of stabilizer shaft are connected to front side of lower control arms by links which have rubber grommets at both ends to provide flexibility at the connections and to prevent rattle.

Both upper and lower control arms are stamped steel, formed

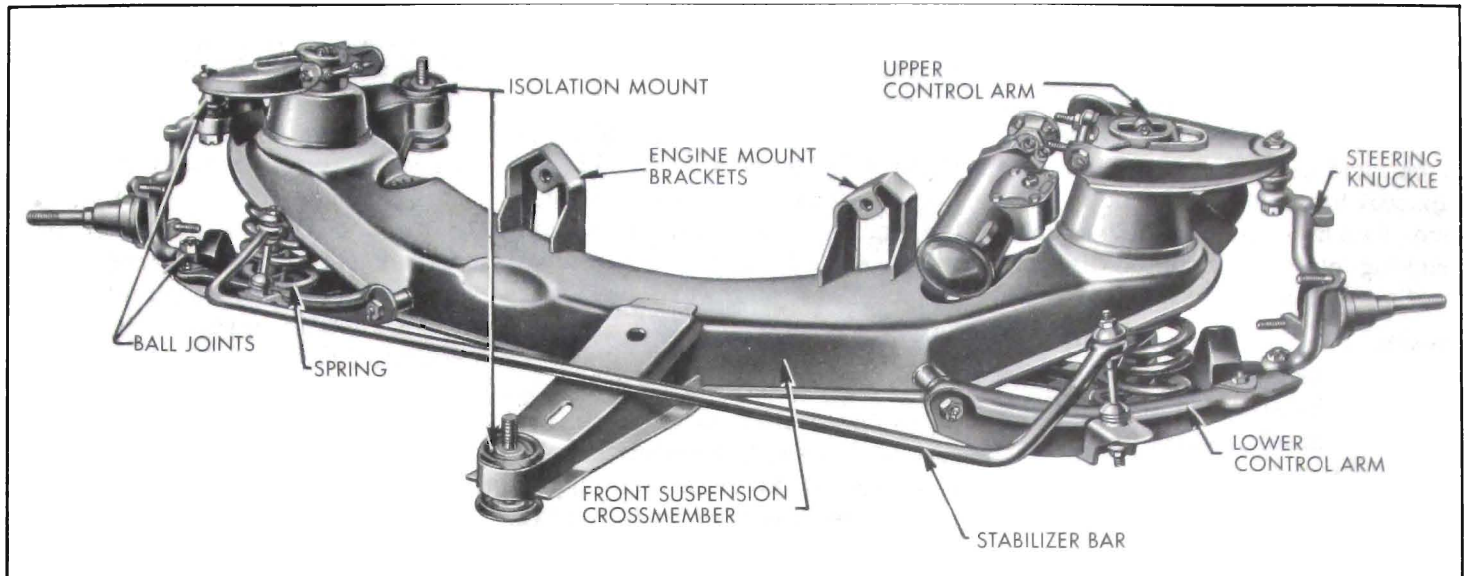

Figure 7-1—Front Suspension

to provide maximum strength. Hardened, replaceable steel threaded bushings are screwed solidly into the inner ends of the arms to provide thread-type bearings on the ends of the control arm shaft. The lower control arm shaft is threaded through bushings welded to the front cross member. The upper control arm shaft is attached to the upper control arm shaft bracket which is integral with the front cross member. Caster and camber are adjusted and maintained by use of shims between the upper control arm shaft and bracket.

The socket portion of the ball and socket assembly is pressed into the outer end of each control arm to connect the steering knuckle to the control arm. The tapered shanks of the ball studs fit into matching tapered holes in the steering knuckles and are held in place by castellated nuts retained with cotter pins.

Rubber seals are provided on upper and lower arm shafts and at ball socket assemblies to exclude dirt and moisture from bearing surfaces. Lubrication fittings are provided at all bearing locations. See Figure 7-2.

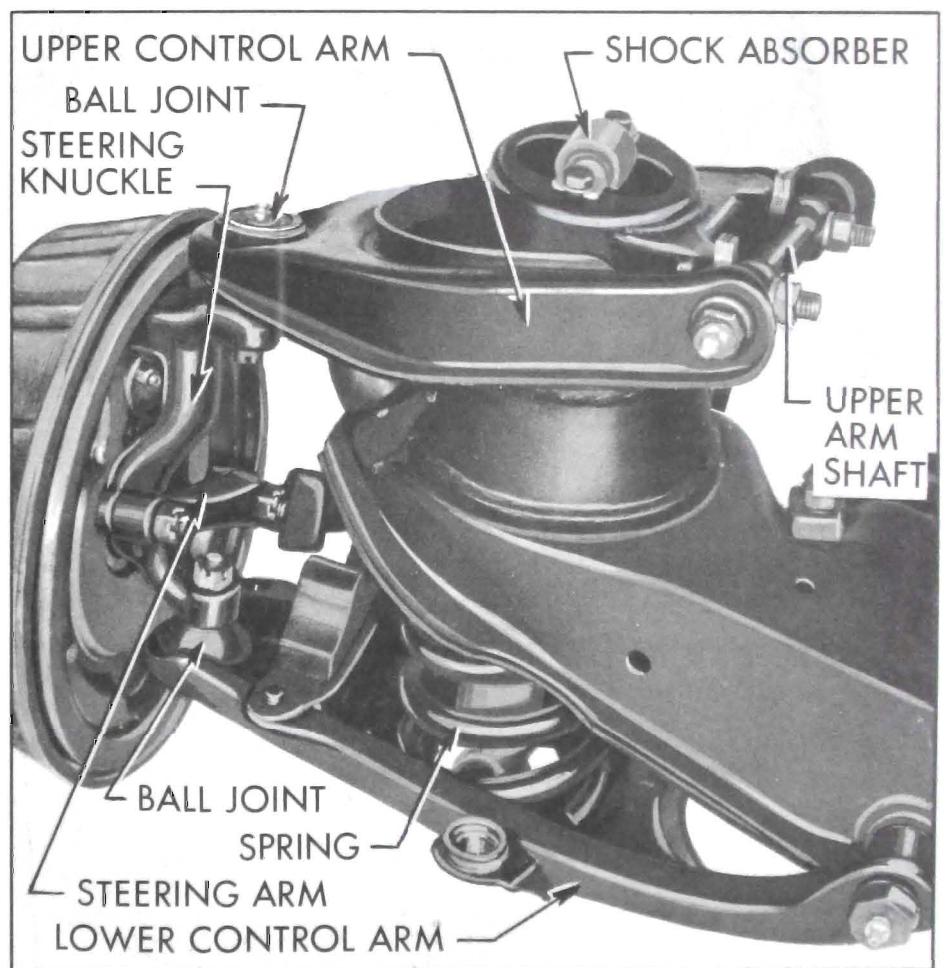

Figure 7-2—Right Steering Knuckle and Ball Joints

The replaceable ball joints which attach the steering knuckle to the upper and lower control arms also provide the bearing surfaces



to withstand the thrust and turning loads. The steering knuckle supports the wheel hub with adjustable cup and cone roller bearings. The outer end of hub is closed by a cap and inner end is sealed with lip seal to exclude dirt and moisture from bearings. The brake backing plate is mounted directly to the steering knuckle.

Brackets are provided on the front suspension cross member to mount the steering gear and the rubber engine mounts.

During brake application two forces act on the front sus-

pension. When the brakes are applied, the torque is transmitted to the backing plate and knuckle assembly through the brake shoes, which tends to rotate the backing plate and knuckle assembly forward. The weight of the car is thrown forward tending to move the front of the car downward. This downward motion is called "front-end dive". In order to minimize "front-end dive", the upper control arm shaft is mounted to the frame so that the front end of the shaft is higher than the rear end at an angle of approximately  $14^\circ$  relative to that of the

lower control arm shaft. Thus, when the braking force is applied, the tendency of the car's front end to dive rotates the backing plate and spindle assembly in a rearward direction, while the braking torque tends to rotate the backing plate and spindle assembly in a forward direction. Therefore, the braking torque creates an upward force nearly equal to the downward (diving) force. In this manner, "front-end dive" is held to a predetermined minimum.

#### b. Rear Suspension

Rear wheels are not independently

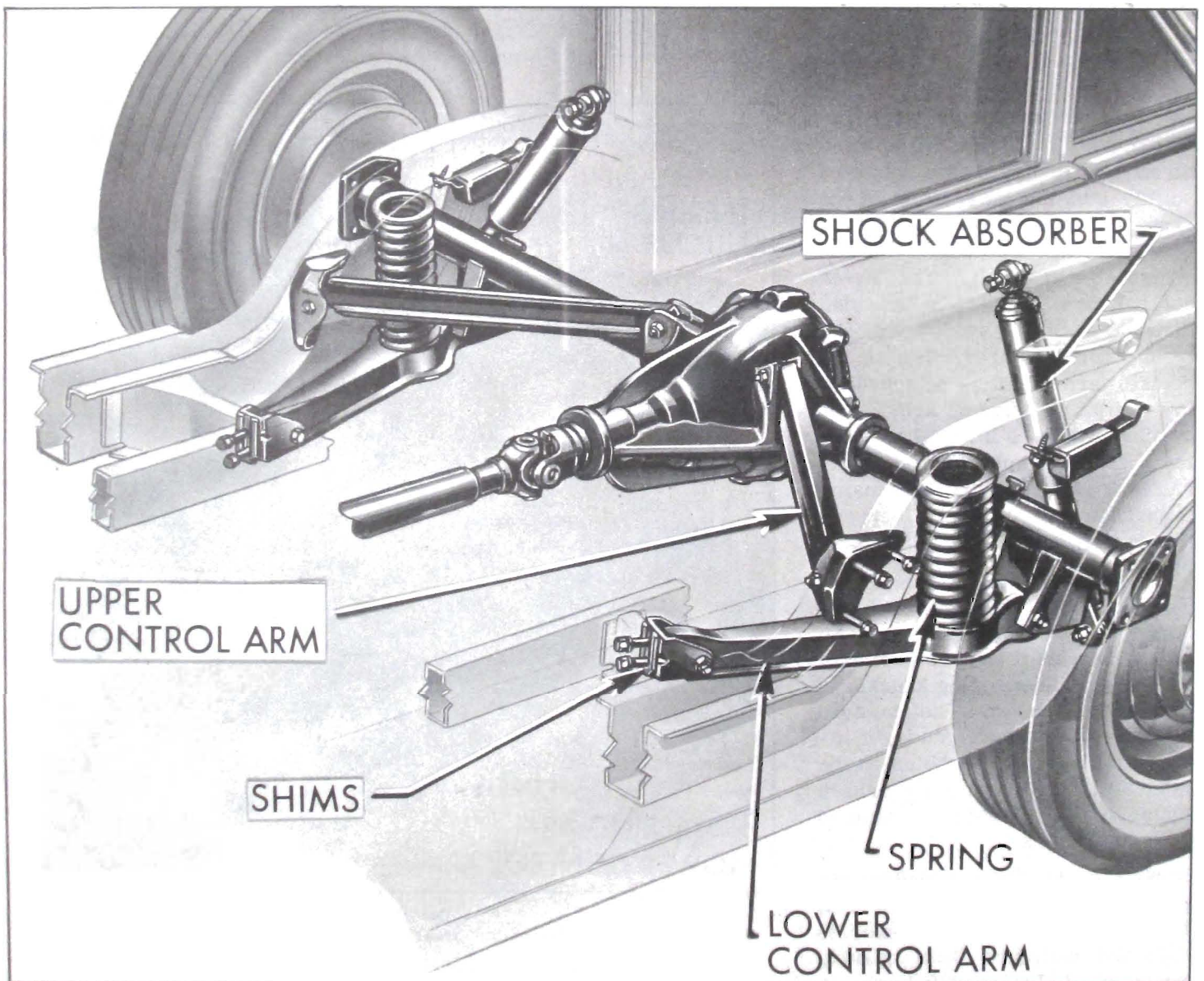

Figure 7-3—Rear Suspension

sprung since they are incorporated in the rear axle assembly. The rear wheels are held in proper alignment with each other by the rigid construction of the rear axle housing.

The rear axle is attached to the body structure by a four link-type suspension system. Two rubber bushed lower control arms mounted between the axle housing and the underbody maintain fore and aft relationship of the axle housing to the chassis, while two rubber bushed upper control arms, angularly mounted with respect to the center line of the car,

control sideways movement of the axle assembly.

The upper control arms are shorter than the lower to cause the axle housing to "rock" or tilt forward on compression. This rocking or tilting lowers the rear propeller shaft to make possible the use of a much lower tunnel through the rear floor pan than would be possible with a conventional rear suspension. See Figure 7-4.

Ride control is provided by two double direct acting shock absorbers angularly mounted between axle housing brackets and underbody.

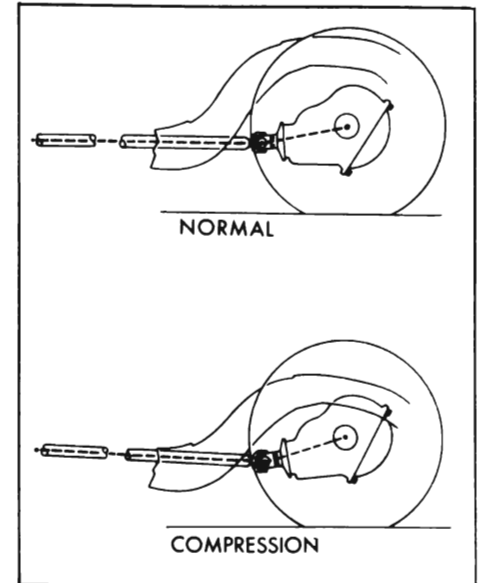

Figure 7-4—Rear Axle Tilting Action