

GROUP 4

CLUTCH, S-M TRANSMISSIONS

SECTIONS IN GROUP 4

Section	Subject	Page
4-A	Clutch	4-1
4-B	3-Speed Synchronesh Transmission	4-7
4-C	4-Speed Synchronesh Transmission	4-23

SECTION 4-A CLUTCH

CONTENTS OF SECTION 4-A

Paragraph	Subject	Page	Paragraph	Subject	Page
4-1	Clutch Specifications	4-1	4-5	Removal, Lubrication and Installation of Clutch	4-5
4-2	Description of Clutch	4-2	4-6	Inspection of Clutch	4-6
4-3	Clutch Trouble Diagnosis	4-3			
4-4	Clutch Adjustment	4-4			

4-1 CLUTCH SPECIFICATIONS

a. Tightening Specifications

Part	Location	Thread Size	Torque Ft. Lbs.
Bolt	Clutch Cover to Flywheel	5/16-18	25-30
Bolt	Flywheel Housing to Cylinder Block	3/8-16	30-35
Stud	Clutch Release Fork Ball	7/16-20	35-40
Bolt	Rear Mounting Pad to Transmission	7/16-14	30-40
Stud	Clutch Equalizer to Cylinder Block	1/2-13	30-35
Bolt	Transmission to Flywheel Housing	7/16-14	40-45

b. Clutch Specifications

Clutch Type	Single Plate-Dry Disc
Clutch Pedal Pressure	32 Lbs.
Clutch Pedal Lash	7/8" to 1"
Driven Plate Diameter	9 1/2" x 6"
Driven Plate Facings -	
Type and Number	Woven, 2
Attachment to Plate	Rivets
Facing Thickness125" ± .002"
Total Effective Area (sq. in.)	42.61
Max. Allowable Run-out at Rear Face of Plate025"
Clutch Springs -	
Type and Number	Coil, 6
Total Pressure (lbs.)	1230
Spring Pressure (lbs.) @ Length	200-210 @ 1 3/4"
Free Length	Approx. 2 1/2"
Press. Plate Driving Lug Clearance in Cover.005" - .008"
Height, Inner Ends of Release Levers to Flywheel	1 7/8"
Max. Allowable Variation030"

4-2 DESCRIPTION OF CLUTCH

A single plate, dry disc clutch is used in cars equipped with synchromesh transmissions. The clutch is of conventional design with coil type clutch springs and three release levers. The release levers are non-adjustable.

a. Clutch Assembly

The clutch cover is bolted to the flywheel and three lugs on the pressure plate engage slots in the cover to transmit torque to the plate. Six clutch springs are located between the cover and the pressure plate. The three clutch release levers are located so that their inner ends are in position to be engaged by the clutch release bearing. The levers pivot on fulcrums bolted to the clutch cover and in the three pressure plate lugs. See Figure 4-1.

The outer ends of the release levers are weighted so that at higher engine speeds where slipping is liable to occur, centrifugal force causes more pressure to be applied on the pressure plate. The faster the clutch

revolves, the greater the pressure exerted against the clutch plate, thereby increasing the torque transmitting ability of the clutch. This additional pressure allows the use of a clutch which requires lower foot pressure at the pedal for normal clutch operation.

When the clutch is in the engaged position, the release levers are clear of the release bearing and the clutch springs cause the pressure plate to clamp the driven plate against the flywheel with sufficient force to transmit power of the engine without slippage. The power drive is from flywheel to clutch cover, cover to pressure plate, and from pressure plate and flywheel to driven plate.

When the clutch is disengaged, the clutch release bearing presses forward on the inner ends of the release levers which pivot and force the pressure plate rearward against the pressure of clutch springs. The pressure plate is moved rearward far enough to free the driven plate. See Figure 4-1.

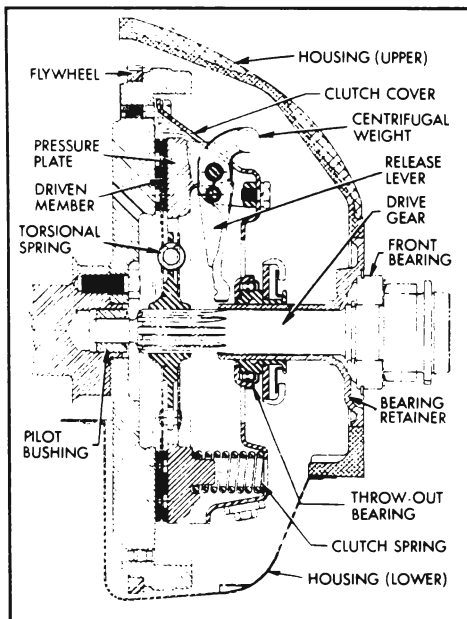

Figure 4-1—Clutch and Flywheel Assembly

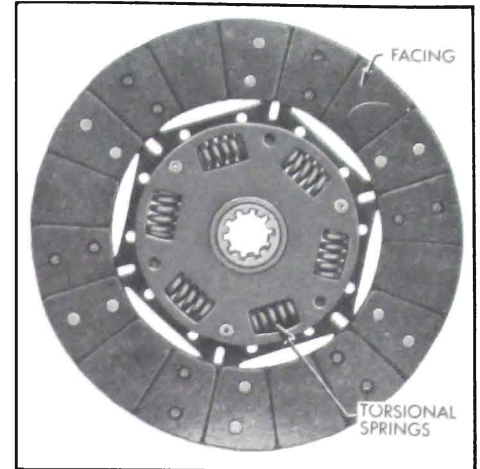

Figure 4-2—Driven Plate—Transmission Side

movement of pressure plate provides an additional clearance of approximately .030" to assure full release of driven plate. See Figure 4-2.

The driven plate assembly is designed to prevent torsional periods of the engine from being transmitted to the transmission gears and causing rattle. This is accomplished by driving the plate hub through torsional coil springs and providing frictional dampening by means of friction between disc and the nuts.

b. Clutch Driven Plate

The clutch driven plate assembly is mounted with a free sliding fit on the transmission main drive gear and is keyed to the gear by ten splines. The front end of the main drive gear is piloted by a bushing pressed into a recess in the rear end of the engine crankshaft. See Figure 4-1.

The outer area of the driven plate is divided into segments which are formed in low waves to provide springs between the plate facings and thereby cushion engagement of the clutch. A molded facing, grooved to give release, is riveted to each side of every segment of the plate. When the clutch is fully released, the waved segments cause the facings to spread approximately .055" and the

c. Clutch Linkage

The clutch pedal is of the suspended type and pivots on a shaft which extends through brackets bolted to the cowl. This shaft is also used to suspend the brake pedal. The clutch pedal returns against a non-adjustable pedal stop under the instrument panel. See Figure 4-3.

A pedal rod extends through the cowl to connect the pedal to the clutch release equalizer. The equalizer pivots between the engine at one end and the frame at the other. The clutch release rod and adjusting swivel extends from the equalizer to the clutch release fork. See Figure 4-4.

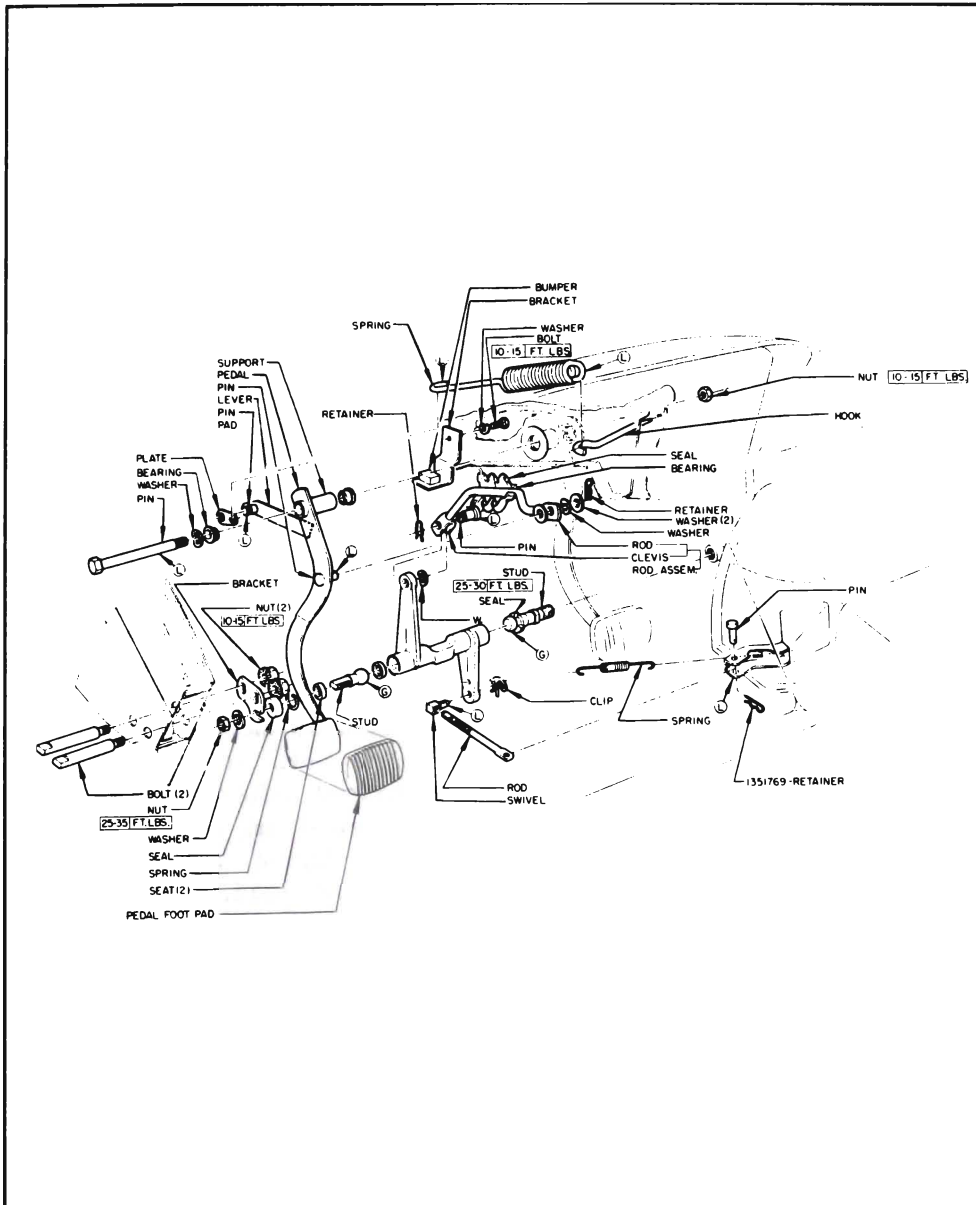

Figure 4-3—Clutch Linkage

A heavy overcenter spring and plate is stretched between a hook, which is anchored through the pedal mounting bracket, and a pin, which is welded to a lever of the clutch pedal assembly.

The front end of the clutch release rod is fastened to the equalizer with an adjustable swivel and a clip; the rear end of the release rod is fastened to the clutch fork with a clevis pin and a retainer pin.

The clutch fork is held in position on a ball stud by a U-shaped re-

tainer spring which is riveted to the fork. A boot around the fork provides a flexible closure for the fork opening in the flywheel housing.

The inner end of the fork is in position to push forward on the throw-out bearing when the clutch pedal is depressed. A U-shaped spring riveted to the fork holds the throw-out bearing in contact with the fork. The release rod length must be adjusted to provide clearance between the throw-out bearing and the clutch release levers (par. 4-4)

The throw-out bearing assembly is mounted over a retainer which retains the transmission main drive gear bearing. The throw-out bearing is filled with lifetime lubricant in production and no further lubrication is required; however, there is a groove in the inner surface which must be filled. See Figure 4-5. Fill groove with wheel bearing lubricant or a heavy grease.

4-3 CLUTCH TROUBLE DIAGNOSIS

a. Excessive Pedal Pressure

The pressure required to depress clutch pedal to toe board should not exceed 32 pounds. If pedal pressure is excessive, make certain that pedal rod is not binding where it passes through the cowl. Thoroughly lubricate equalizer with chassis lubricant. Lubricate all linkage pins with engine oil. If excessive pedal pressure still exists after release linkage is properly lubricated, lubricate internal working parts of clutch as described in paragraph 4-5.

b. Clutch Noise

Squeaking and grind noises during clutch pedal operation are usually caused by heavy friction in the release linkage or internal parts of clutch assembly. Before condemning the throw-out bearing, thoroughly lubricate equalizer and, if necessary, lubricate internal working parts of clutch as described in paragraph 4-5.

c. Clutch Grab or Chatter

A very slight amount of oil on driven plate facings will cause clutch grab and chatter. A new driven plate must be installed if original plate facings contain oil since removal of oil from facings is not practical.

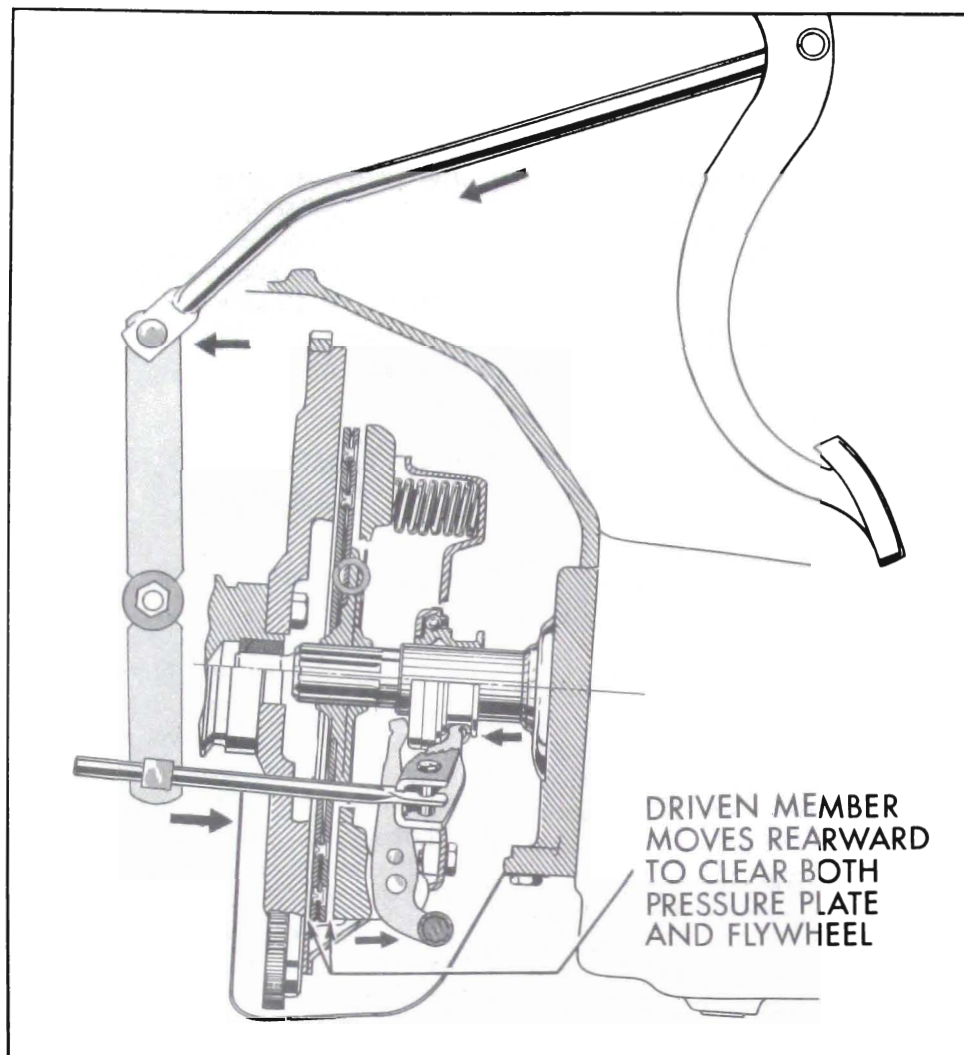

Figure 4-4—Clutch Releasing Action

When oil is found on facings, examine pilot bushing, transmission drainback, rear engine bearing, and oil leaks which might drain back into clutch housing between upper and lower flywheel housings.

d. Clutch Drag or Failure to Release

To test for clutch drag or failure to release depress clutch pedal to toeboard and put into low gear. Hold pedal depressed and shift transmission to neutral, wait about 15 seconds with pedal depressed and again shift into low gear. If clutch is not releasing completely a gear clash will occur.

If test shows that clutch is not releasing properly, check clutch pedal lash (par. 4-4) and check release linkage for lost motion. Correct as necessary and again test for clutch drag.

If clutch drag cannot be corrected in release linkage, remove clutch and check height of release levers. Check driven plate for oil soaked or cracked facings, also for run-out and free movement on main drive gear (par. 4-6).

e. Clutch Slipping

First make certain that clutch pedal is adjusted for specified lash ($7/8$ " to 1") and that pedal is not binding. One type of clutch slippage is sometimes wrongly

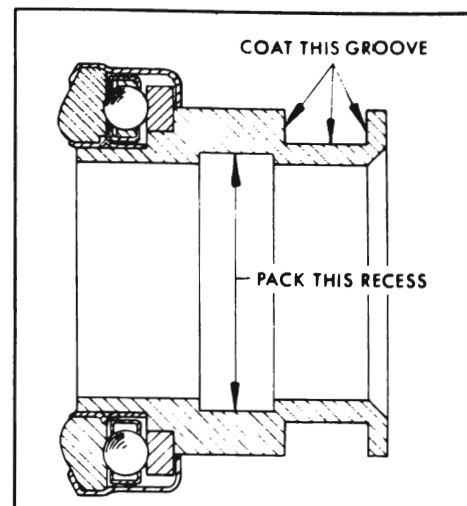

Figure 4-5—Lubricate Bearing

diagnosed as due to weak clutch springs. This slippage occurs during gear shifting and full engagement of the clutch is not obtainable until the engine speed is reduced. After full engagement is obtained no further slippage occurs during acceleration or under full load. This condition is usually due to the clutch driven plate hub sticking on the splines of the transmission main drive gear. Correction can be made by removing the clutch and thoroughly cleaning splines of driven plate and main drive gear then applying a light coating of Lubriplate. Make sure that release lever pins are not binding, and that pressure plate driving lugs are not binding in clutch cover.

4-4 CLUTCH ADJUSTMENT

Pedal lash (free pedal) must be adjusted occasionally to compensate for normal wear of clutch facings. As the driven plate wears thinner, pedal lash decreases.

It is very important to maintain pedal lash at all times. Insufficient pedal lash will cause the throw-out bearing to ride against the release levers all of the time, resulting in abnormal wear of these parts. It may also cause clutch slippage and abnormal wear of the driven plate, flywheel, and

pressure plate if pressure on the release levers is enough to prevent positive engagement of the clutch.

Check pedal lash (free pedal) by pushing on the pedal pad with the hand. Pedal lash should be 7/8" to 1" measured at the pedal pad. (See Figure 4-3).

Adjust pedal lash as follows:

1. Make certain that clutch pedal returns firmly against pedal bumper when pedal is released. If pedal does not contact bumper, check pedal and linkage for binding or lack of lubrication.
2. With car raised, pull outer end of clutch fork rearward until throw-out bearing contacts clutch release levers. Free movement at outer end of fork should be approximately 3/16". See Figure 4-3.
3. If free movement is not about 3/16", remove clevis pin from rear end of clutch release rod and rotate rod as required to make free movement correct. Reinstall clevis pin and retainer pin.
4. Check to make sure pedal lash is between 7/8" and 1".

4-5 REMOVAL, LUBRICATION AND INSTALLATION OF CLUTCH

a. Removal of Clutch

1. Remove transmission as described in paragraph 4-12. Remove flywheel lower housing.
2. Remove throw-out bearing.
3. Disconnect release rod from release fork by removing clevis pin. Unhook fork boot from opening in flywheel housing. See Figure 4-6.
4. Push inward on release fork to free it from ball stud in flywheel housing and remove fork through bottom of housing.

5. Mark clutch cover and flywheel with a center punch so that cover can be reinstalled in the same position on flywheel in order to preserve engine balance.

6. Loosen each clutch cover bolt a turn at a time in order to relieve clutch spring pressure evenly and thereby avoid distortion of the cover. Metal spacers (such as 1/4" nuts) placed between release levers and inner edge of clutch cover will aid removal and later reinstallation by holding clutch springs partially compressed.

7. Support pressure plate and cover assembly while removing last bolts, then remove pressure plate, then the driven plate.

b. Lubrication of Clutch

Lubrication of the clutch release equalizer is required when the clutch is overhauled; if lubrication becomes necessary between overhauls to eliminate squeaks or excessive pedal pressure, the clutch must be removed from the car.

1. Very sparingly apply wheel bearing lubricant in pilot bushing in crankshaft. If too much lubricant is used, it will run out on face of flywheel when hot and ruin the driven plate facings. Make sure that surface of flywheel is clean and dry.

2. Make sure that splines in driven plate hub are clean and apply a light coat of Lubriplate.

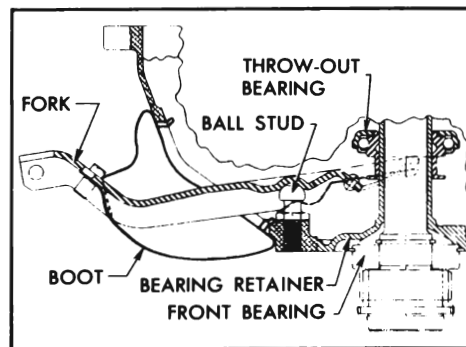

Figure 4-6—Clutch Release Fork

Apply a light coat of Lubriplate on transmission drive gear splines. Slide driven plate over transmission drive gear several times. Remove driven plate and wipe off all excess lubricant pushed-up by hub of plate. Driven plate facings must be kept clean and dry.

3. Fill groove in throw-out bearing with wheel bearing lubricant (See fig. 4-5). Make sure transmission front bearing retainer sleeve is clean and apply a light coat of wheel bearing lubricant. Slide throw-out bearing over transmission retainer several times. Remove throw-out bearing and wipe off all excess lubricant pushed up by hub of bearing.

4. If clutch pressure plate driving lugs are dry, brush a little Lubriplate in between clutch cover and driving lugs, also between driving lugs and release levers. Wipe off any excess lubricant.

5. Apply Lubriplate to ball stud in flywheel housing and to ball seat in clutch fork.

c. Installation of Clutch

1. Install pressure plate assembly in into the flywheel housing. Slide driven plate on pressure plate with raised torsional spring part projecting into center of pressure plate. Be sure to align marks on clutch cover with marks on flywheel. Install cover bolts and lockwasher, but do not tighten bolts.

2. Insert a spare main drive gear through hub of driven plate and into pilot bushing. Tighten each clutch cover bolt one turn at a time to draw cover down evenly and avoid distortion of cover. While tightening cover bolts, move main driven gear from side to side to center driven plate with pilot bushing. If plate is not properly centered, it will be very difficult to slide transmission into place. Make sure all cover bolts are tightened securely.

4-6 CLUTCH

CLUTCH, S-M TRANSMISSIONS

3. Remove three spacers from between clutch cover and release levers, if used.
4. Install clutch fork through bottom of flywheel housing; push outward to engage spring clip with ball stud. Hook fork boot on edge of flywheel housing opening.
5. Install throw-out bearing on fork. **CAUTION: Entire end of fork, including blued spring, must engage throw-out bearing within groove.**
6. Connect clutch fork to release rod with clevis pin. Adjust clutch pedal lash as described in paragraph 4-4.
7. Install transmission as described in paragraph 4-12. Be sure to use guide pins to avoid damage to clutch driven plate.
8. Install flywheel lower housing.
9. Road test car for clutch performance. Under no circumstance should the clutch be harshly used immediately after installation of a new driven plate, flywheel, or pressure plate. Sudden engagement of clutch with engine running at abnormal speed, or continual slipping of clutch, may permanently injure driven plate facings and may cause scoring of flywheel and pressure plate. When these parts are new they must be given moderate use for several days until burnished. Be sure that car owner is advised of this requirement.

4-6 INSPECTION OF CLUTCH

Wash all metal parts of clutch, except release bearing and driven plate, in suitable cleaning solution to remove dirt and grease. Soak release bearing in cleaning

solution would permit solution to seep into bearing and destroy the lubricant. Soaking driven plate in cleaning solution would damage the facings.

1. Flywheel and Pressure Plate. Examine friction surfaces of flywheel and pressure plate for scoring or roughness. Slight roughness may be smoothed with fine emery cloth, but if surface is deeply scored or grooved the part should be replaced.

2. Clutch Cover. Inspect clutch cover for cracks or distortion. Check clearance between pressure plate driving lugs and edges of slots in cover, using feeler gauges. The clearance should be .005" to .008"; excessive clearance may cause rattle when engine is intermittently accelerated with clutch disengaged.

3. Clutch Driven Plate. Inspect driven plate for condition of facings, loose rivets, broken or very loose torsional springs, and flattened cushion springs. See Figure 4-2.

If facings are worn down near rivets or are oily, the plate assembly should be replaced. A very slight amount of oil on clutch facings will cause clutch grab and chatter. A large amount of oil on facings will cause slippage. Removal of oil by solvents or by buffing is not practical since oil will continue to bleed from facing material when hot.

When oil is found on driven plate facings, examine transmission drainback hole, pilot bushing, engine rear main bearing and other points of oil leakage.

Test the fit of driven plate hub on transmission main drive gear;

an easy sliding fit should exist. Regardless of whether the old plate or a new one is to be installed, the plate should be checked for run-out. This check can be made by sliding the driven plate, front side first, over the transmission main drive gear until it is tight on the spline, then setting up a dial indicator to bear against the plate facing as shown in Figure 4-9. While holding firmly against front end of main drive gear to take up play in main drive gear bearing, slowly rotate driven plate and observe the amount of run-out shown by indicator. If run-out of front facing exceeds .025" the plate should not be used since it is not practical to correct excessive run-out by bending.

4. Bearings. Inspect clutch release bearing for scoring or excessive wear on front contact face. Test for roughness of balls and races by pressing and turning front race slowly. Inspect main drive gear pilot bushing in crankshaft. If bushing is rough or worn it should be replaced.

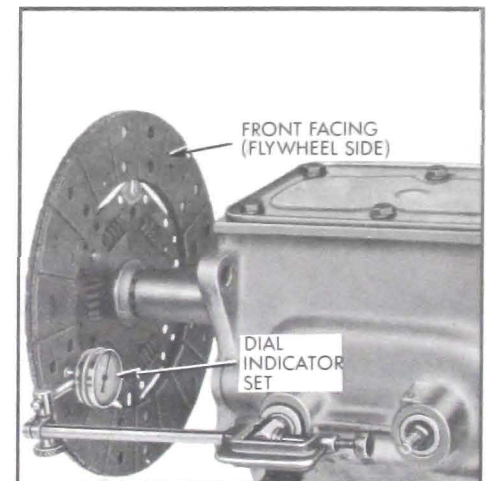

Figure 4-9—Checking Driven Plate for Run-out