

SECTION 2-D CYLINDER HEAD AND VALVE MECHANISM SERVICE

CONTENTS OF SECTION 2-D

Paragraph	Subject	Page	Paragraph	Subject	Page
2-14	Cylinder Head and Valve Service	2-22	2-16	Timing Chain, Cover and Camshaft Service	2-30
2-15	Hydraulic Valve Lifter Service	2-27			

2-14 CYLINDER HEAD AND VALVE SERVICE

a. Cylinder Head Removal

1. Intake Manifold Removal

See subparagraph f for installation of intake manifold.

(a) Drain radiator and cylinder block.

(b) Remove air cleaner and silencer. Disconnect all pipes and hoses from carburetor. Remove coil. Disconnect water temperature indicator wire from switch.

(c) Disconnect accelerator and transmission linkage at carburetor. Disconnect throttle return spring. Disconnect positive crankcase ventilator hose at valve.

(d) Slide front thermostat by-pass hose clamp back on hose. Disconnect by-pass hose at timing chain cover to allow coolant to drain from manifold. Disconnect upper radiator hose at outlet.

(e) On V-8 jobs, disconnect heater hose (if car is so equipped) at heater water temperature control valve inlet. Push end of hose down to allow coolant to drain from intake manifold. Take precautions against coolant remaining on intake manifold gasket where it might spill into the engine when the gasket is removed.

(f) On V-6 jobs, disconnect heater hose at intake manifold.

(g) Remove bolts attaching intake manifold to cylinder heads.

(h) Remove intake manifold and carburetor as an assembly. On V-6 jobs, remove intake manifold gasket and seals.

(i) On V-8 jobs, make sure there is no coolant present, then remove intake manifold gasket clamps and remove gasket. Remove rubber gasket seal. See Figure 2-34.

2. Rocker Arm Assembly Removal

See subparagraph c for replacement of rocker arms and subparagraph e for installation of rocker arm shaft assemblies.

(a) Pull spark plug wire retainers from brackets on rocker arm cover. Disconnect spark plug wires at plugs and swing wires and retainer out of the way.

(b) Remove four screws attaching rocker arm cover to cylinder head. On right side remove positive crankcase ventilator valve. Remove rocker arm cover and gasket. Remove rocker arm shaft bracket to cylinder head attaching bolts. Remove rocker arm and shaft assembly. Oil baffle is mounted under rear bolts on right rocker arm and shaft assembly.

(c) Remove push rods.

(1) If lifters are to be serviced, remove them. Otherwise protect the lifters and camshaft from the entrance of dirt by covering the area with clean cloths.

3. Generator and Power Steering Pump Bracket Removal

(a) Disconnect battery cable and remove generator mounting bracket and brace attaching bolts. Lay generator on suspension cross member.

(b) Remove power steering pump rear bracket to cylinder head attaching bolts. Loosen bracket at pump (V-8 only).

(c) If automatic transmission equipped, remove filler tube support to exhaust manifold bolt.

(d) Remove exhaust manifold to exhaust pipe bolts.

4. Cylinder Head Bolts

(a) Remove cylinder head bolts.

(b) Remove cylinder head with exhaust manifold attached.

(c) If work is to be done on head, remove exhaust manifold on bench.

b. Reconditioning Valves and Guides

CAUTION: Aluminum can be dented or nicked if carelessly handled. Use particular care to protect gasket surfaces against damage.

1. Place cylinder head on clean smooth surface.

2. Using suitable spring compressor, such as J-8062, compress valve spring and remove

cap retainers. Release tool and remove spring and cap. See Figure 2-22.

NOTE: Cap retainers are copper colored for identification purposes only.

3. Remove valve. Valves should be set aside so they may be re-installed in original location. A small board with numbered holes is handy for this purpose.

4. Remove carbon from combustion chamber of heads, using care to avoid scratching the head or the valve seats. A soft wire brush (such as J-8358) is suitable for this purpose.

5. Clean carbon and gum deposits from valve guide bores. Use Reamer J-8814.

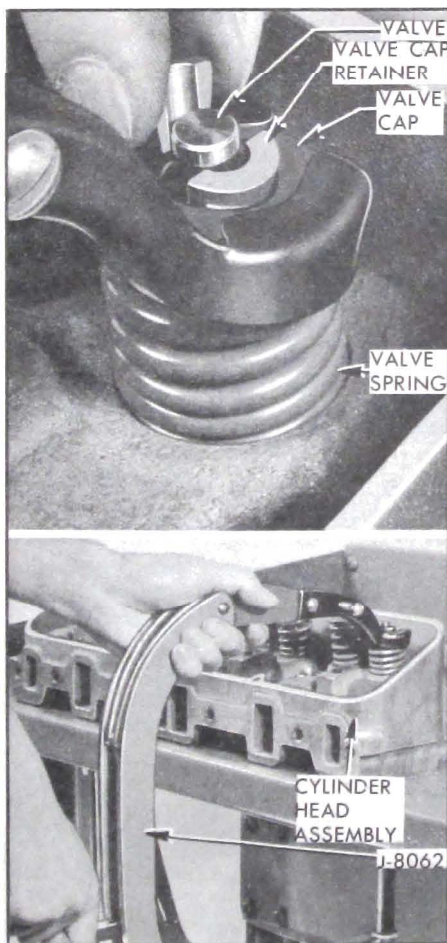

Figure 2-22—Removing and Installing Valve Cap Retainers

6. Clean valves. Inspect valve faces and seats for pits, burned spots or other evidence of poor seating.

7. Grind or replace valves as necessary. If a valve head must be ground to a knife edge to obtain a true face, the valve should be replaced; as a sharp edge will run too hot. 45° is the correct angle for valve faces.

8. Check fit of valve in valve guide. If clearance is excessive, correct V-8 as follows:

(a) Drive old guide out from combustion chamber side using Tool J-267. See Figure 2-23.

(b) Lubricate and install new guide from top of head using Tool J-8813. The tool is designed to bottom when the guide is correctly positioned. See Figure 2-24.

NOTE: Service guides are .001" larger O.D. than original equipment in order to obtain a good press fit in the aluminum cylinder head.

NOTE: New valve guides are reamed to size, however, the installing operation will alter the I.D. slightly, requiring a finish ream.

(c) Finish ream a newly installed valve guide to size with Reamer J-8814. Use a tap wrench to turn

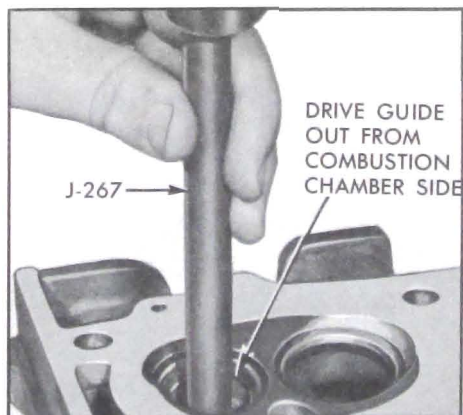

Figure 2-23—Removing Valve Stem Guide (V-8 only)

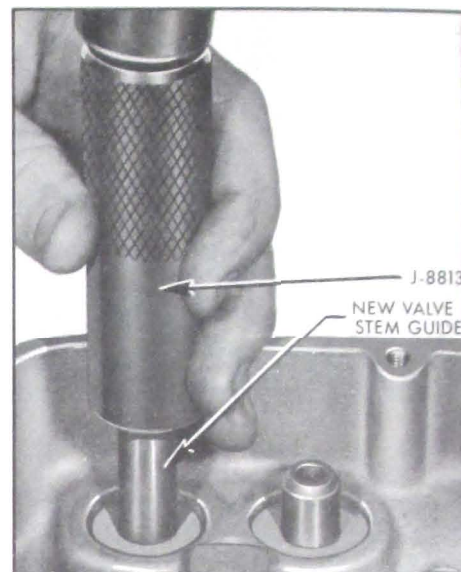

Figure 2-24—Installing New Valve Guide (V-8 only)

the reamer clockwise. See Figure 2-35.

V-6 valve stem guides are non-replaceable, due to being cast in place. If a V-6 valve stem has excessive clearance in its guide, the guide must be reamed .004" oversize, using Reamer J-5830-1. See Figure 2-25 .004" oversize valves are available through the Parts Department.

9. True up valve seats to 45° . Cutting a valve seat results in lowering the valve spring pressure and increases the width of the seat. The nominal width of the valve seat is $1/16"$. If a valve seat is over $5/64"$ wide after truing up it should be narrowed to specified width by the use of 20° and 70° stones.

Improper hydraulic valve lifter operation may result if valve and seat are refinished to the extent that the valve stem is raised more than .050" above normal height. In this case it will be necessary to grind off the end of the valve stem or replace parts.

The normal height of the valve stem above the valve spring seat surface of the head is 1.825".

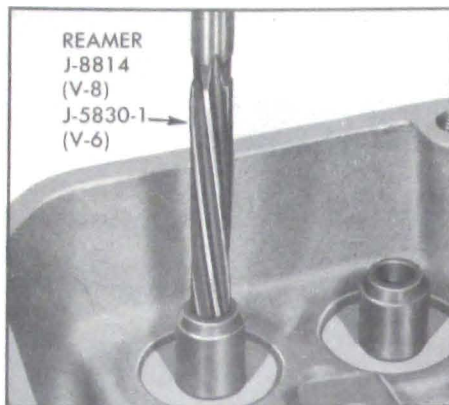

Figure 2-25—Reaming Valve Guide

10. Lightly lap the valves into seats with fine grinding compound. The refacing and reseating operations should leave the refinished surfaces smooth and true so that a minimum of lapping is required. Excessive lapping will groove the valve face preventing a good seat when hot.

11. Test valves for concentricity with seats and for tight seating. The usual test is to coat the valve face lightly with Prussian blue and turn the valve against seat. If the valve seat is concentric with the valve guide a mark will be made all around the seat, while if the seat is not concentric with the guide, a mark will be made on only one side of the seat. Next, coat the valve seat lightly with Prussian blue. Rotate the valve against the seat to determine if the valve face is concentric with the valve stem, and if the valve is seating all the way around. Both of these tests are necessary to prove that a proper seat is being obtained.

12. Lube with "Service MS" engine oil and reinstall valves, valve springs, caps and cap retainers, using same equipment used for removal. Install valve spring with closely wound coils toward the cylinder head. See Figure 2-26.

c. Replacement of Rocker Arms

See subparagraph a, Step 2 for

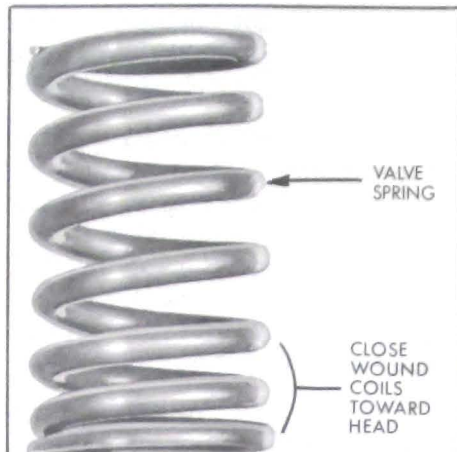

Figure 2-26—Valve Spring

rocker arm shaft assembly removal.

1. Remove cotter pin, plain washer and spring washer from each end of the rocker arm shaft.

2. Remove bracket bolts. Slide rocker arms and brackets off shaft.

3. Clean and inspect all parts, taking particular care to clean out all oil holes. Replace parts that are excessively worn.

4. Assemble springs, rocker arms and brackets on shaft as shown in Figure 2-27. Take care that the assembly for the right side has the notch in the shaft forward and the left side has the notch to the rear. See Figure 2-28.

5. Install spring washer, flat washer and cotter pin on each end of shaft in order named.

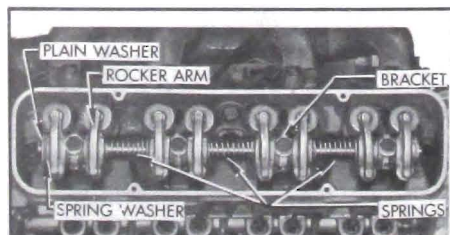

Figure 2-27—Rocker Arm Shaft Assembly (V-8 shown)

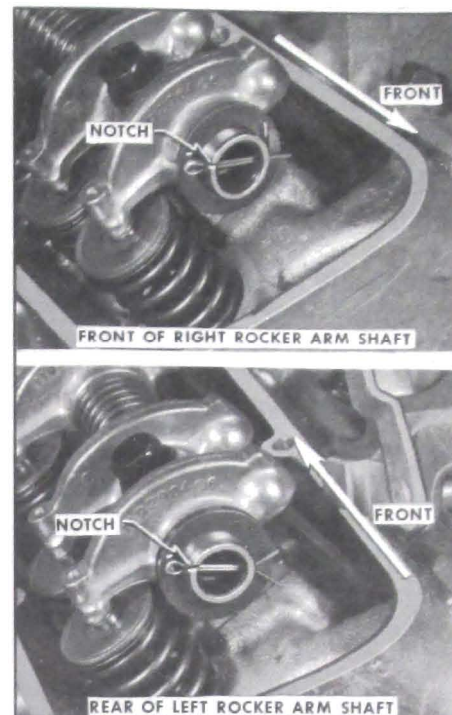

Figure 2-28—Rocker Arm Shaft Installation

6. Install bolts with plain washers through the brackets and shaft so the notch in the right assembly is up and to the front and the notch in the left assembly is up and to the rear. See Figure 2-28.

d. Installation of Cylinder Head

CAUTION: Aluminum parts can be damaged by careless handling. Be particularly careful of gasket surfaces.

1. Wipe off engine block gasket surface and be certain no foreign material has fallen in the cylinder bores, bolt holes, or in the valve lifter area. It is good practice to clean out bolt holes with an air hose.

2. Install new head gasket on cylinder block. Dowels in the block will hold the gasket in position. Always handle gaskets carefully to avoid kinking or damage to the surface treatment of the gasket. Do not use any type of sealing material on head gaskets. The gaskets are coated with a

special lacquer to provide a good seal, once the parts have warmed up.

3. Assemble exhaust manifold to cylinder head with bolts and locking plates as shown in Figure 2-29. Torque bolts to 10-15 ft. lbs.

NOTE: Automatic transmission filler tube bracket fastens to rear bolt, right side.

4. Clean gasket surface of cylinder head and carefully set in place on the engine block dowel pins.

5. Clean and lubricate the head bolts with "Perfect Seal" sealing compound. Install bolts as shown in Figure 2-30 on V-8's or Figure 2-31 on V-6's.

6. Tighten the head bolts a little at a time about three times

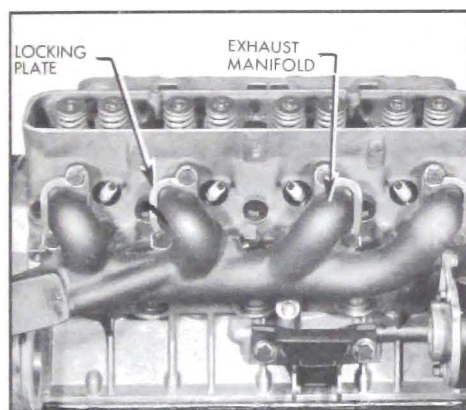

Figure 2-29—Exhaust Manifold Installation (V-8 shown)

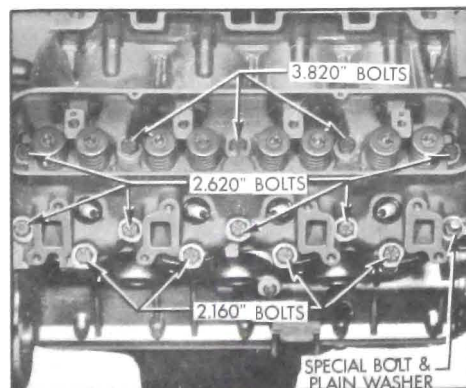

Figure 2-30—V-8 Cylinder Head Bolt Installation

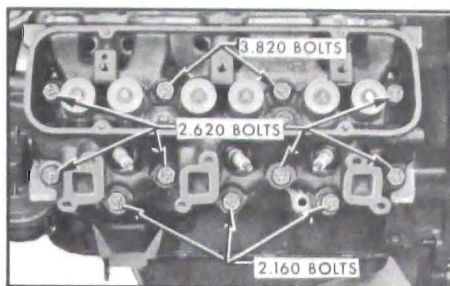

Figure 2-31—V-6 Cylinder Head Bolt Installation

around in the sequence shown in Figure 2-30 on V-8's and Figure 2-31 on V-6's, then torque the bolts in the same sequence to 65-70 ft. lbs.

NOTE: Damage to the cylinder block threads can result if bolts are not lubricated with "Perfect Seal" prior to installation, or if the bolts are tightened excessively.

Use an accurate torque wrench when installing head bolts and do not overtighten. Uneven tightening of the cylinder head bolts can distort the cylinder bores, causing compression loss and excessive oil consumption.

e. Installation of Rocker Arm and Shaft Assemblies

1. Install push rods through cylinder head openings so rods are correctly positioned on lifter plungers.

2. Wipe bases of rocker arm shaft brackets and bracket bosses on cylinder head clean.

3. Check notch on one end of rocker arm shaft. Be sure it is positioned as shown in Figure 2-28.

4. Tilt the rocker arms toward the push rods and locate the top of each push rod in its rocker arm seat.

5. Draw down the rocker arm and shaft assembly by tightening the bracket bolts a little at a

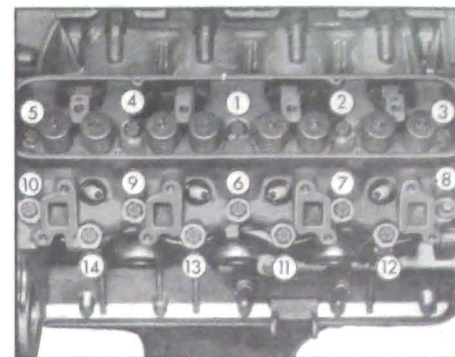

Figure 2-32—V-8 Cylinder Head Bolt Tightening Sequence (Right Shown)

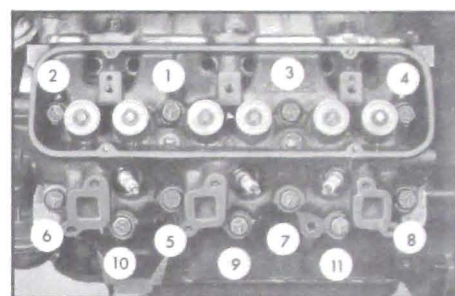

Figure 2-33—V-6 Cylinder Head Bolt Tightening Sequence (Left Shown)

time. Use a reliable torque wrench to torque the bracket bolts to 30 ft. lbs. Do not overtighten.

6. Install rocker arm cover and gasket. On right side install vent pipe.

7. Connect spark plug wires and set retainers in position on brackets.

f. Installation of Intake Manifold

1. V-8

(a) Install new intake manifold gasket seals as shown in Figure 2-34. Make sure the ends of the seals fit properly in the notches provided in the block. Place manifold gasket in position so open bolt hole is positioned as shown in Figure 2-36.

(b) Install gasket clamps and bolts but do not tighten bolts as yet.

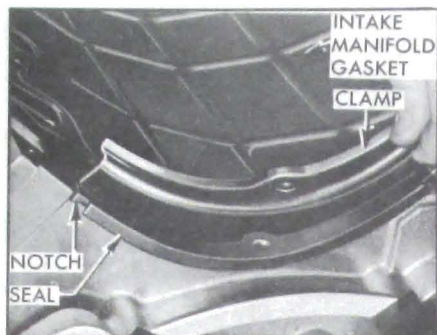

Figure 2-34—V-8 Intake Manifold Gasket, Clamp and Seal

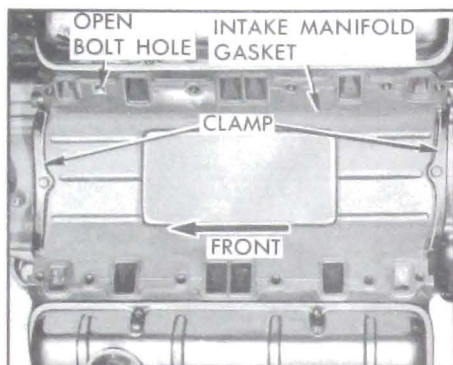

Figure 2-35—V-8 Intake Manifold Gasket and Clamps - Top View

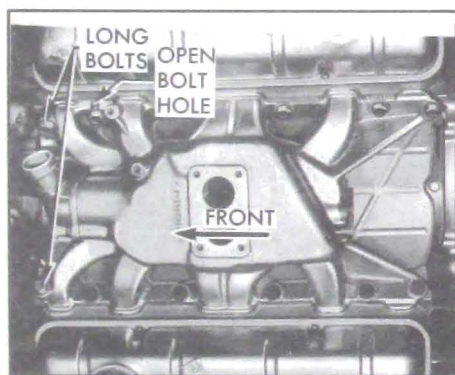

Figure 2-36—V-8 Intake Manifold Installation

(c) Set intake manifold in place and connect thermostat by-pass hose to water pump.

(d) Check to be sure the manifold and gasket clamp are properly positioned. Start all the bolts into the cylinder head. The two longer bolts are installed in the forward location on each side. See Figure 2-36.

NOTE: Automatic transmission

linkage idler bracket mounts at two left rear manifold attaching bolts.

(e) Tighten all manifold to cylinder head bolts a little at a time until all are snug, then torque to 25 to 30 ft. lbs. Use a reliable torque wrench and do not over-tighten. Tighten clamp bolts at front and rear of gasket to 10 to 15 ft. lbs. torque.

(f) Connect heater and thermostat by-pass hoses. Connect upper radiator hose.

(g) Reconnect carburetor fuel and vacuum pipes. Install coil.

(h) Reconnect throttle and (if so equipped) automatic transmission linkage.

(i) Close radiator drain cock, reinstall cylinder block water jacket drain plugs and fill cooling system.

(j) Reinstall air cleaner.

2. V-6

(a) Place new rubber manifold seat in position at front and rear rails of cylinder block. Be sure pointed ends of seal fit snugly against block and head. See Figure 2-37.

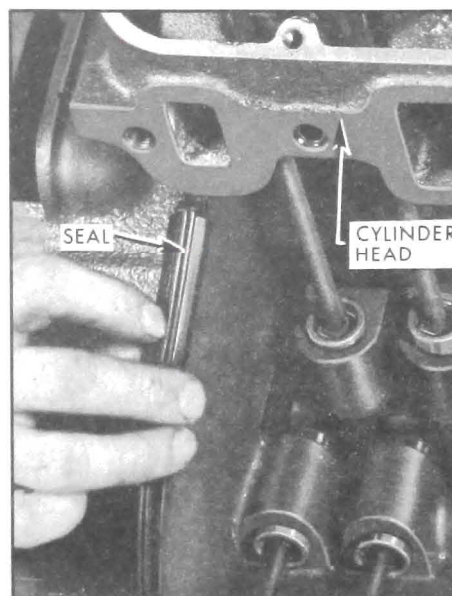

Figure 2-37—Installing V-6 Intake Manifold Seals

(b) Set intake manifold in place carefully and start two guide bolts on each side. See Figure 2-38.

(c) Lift the manifold slightly and slip the gaskets into position as shown in Figure 2-38. Take care to see that the gasket is installed with the three intake manifold ports aligned with the head and manifold. The gasket should be installed as shown in Figure 2-38 on the left side of installation.

(d) Install manifold attaching bolt in open bolt hole as shown in Figure 2-39. Open bolt hole is held to close tolerances and the bolt in this location serves to locate the manifold fore and aft.

(e) Install remaining manifold to cylinder head bolts. Longer bolts at forward location. Torque bolts alternately and evenly to 25-30 ft. lbs.

NOTE: Automatic transmission

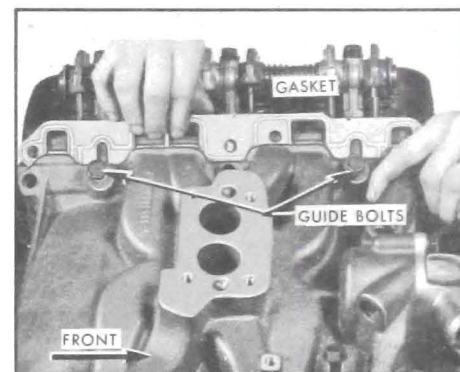

Figure 2-38—Installing V-6 Intake Manifold Gasket

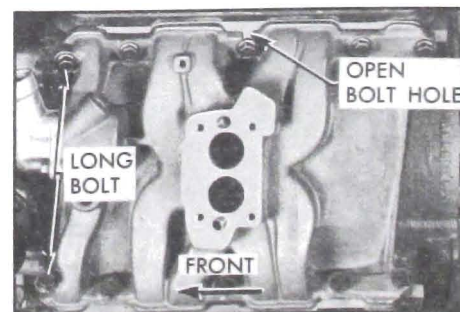

Figure 2-39—V-6 Intake Manifold Installation

idler lever bracket mounts under two rear bolts left side.

2-15 HYDRAULIC VALVE LIFTER SERVICE

a. Removal of Valve Lifters

1. With air hose and cloths, clean dirt from cylinder heads and adjacent parts to avoid getting dirt into engine. It is extremely important to avoid getting dirt into the valve lifters.

2. Remove Intake Manifold (par. 2-14).

3. Remove Rocker Arm Covers and Rocker Arm and Shaft Assemblies (par. 2-14).

4. Remove push rods and remove valve lifters that require service. Place lifters in a wooden block having numbered holes or use other suitable means of identifying them according to original position in the engine.

5. If less than a complete set of lifters is being removed, immediately disassemble one or two for presence of dirt or varnish. If lifters contain dirt or varnish, it is advisable to remove all lifters for cleaning and inspection. Otherwise, it will be satisfactory to service only those lifters that are not operating properly.

6. Examine the cam contact surface at lower end of lifter body. If this surface is excessively worn, galled, or otherwise damaged, discard the lifter assembly. In this case also examine the mating camshaft lobe for excessive wear or damage.

b. Cleaning Tank J-5821 and Cleaning Fluids

Cleaning Tank J-5821 is designed to permit a systematic and thorough cleaning of hydraulic valve lifter parts. It provides three compartments for cleaning

fluids, two 16-compartment cleaning trays, one small tray for special tools and a removable cover. The two cleaning trays allow one set of lifters to be soaking while another set is being worked on. The cover, placed on bench in front of tank, provides an easily cleaned working surface. See Figure 2-40.

The left hand compartment of tank is for cleaning solvent in which parts are soaked after disassembly. The solvent required should either dissolve the varnish deposit on lifter parts after soaking for not longer than one hour or soften the varnish so that it can be removed by wiping. Gulf Motor Flush, or an equivalent solvent, will effectively clean lifter parts.

When selecting a cleaning solvent, careful consideration should be given to its effect upon the hands. The directions and safety precautions of the manufacturer should be understood and observed to avoid personal injury. A wise safety rule is to wear rubber gloves when handling parts that are wet with cleaning solvent.

The middle compartment of tank is for clean kerosene to be used for cleaning parts after removal from the cleaning solvent. The right hand compartment is for clean kerosene to be used exclusively for final rinsing of parts just before assembly.

When the cleaning tank is not being used the cover should be installed to exclude dirt from the

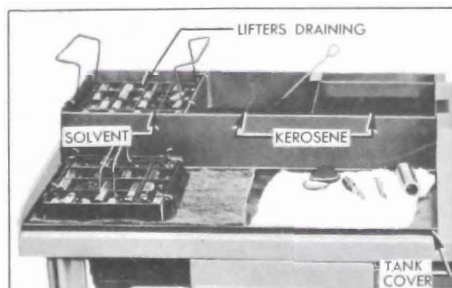

Figure 2-40—Tank J-5821 Set Up for Cleaning Lifter Parts

cleaning fluids. As a further precaution, do not use the tank for any parts except hydraulic valve lifters.

To avoid early contamination and deterioration of the cleaning solvent a separate pan of suitable size should be provided so that a tray of lifter parts can be flushed in kerosene before it is placed in the solvent.

c. Disassembly and Cleaning of Lifters

1. Disassemble each valve lifter by using a push rod to hold down the push rod seat while removing the plunger retainer from the lifter body, using Retainer Remover J-5238. See Figure 2-41, View A. Remove push rod seat and plunger from lifter body.

a. If a plunger sticks in lifter body place lifter in large end of Plunger Remover J-4160, with plunger inward. While holding lifter with thumb, rap the open end of remover against a block of wood with just enough force to jar the plunger from body. See Figure 2-42.

2. Drain oil out of body into waste can and remove the ball retainer, ball, ball spring, and plunger spring. A strainer placed over waste can will prevent dropping these parts into can.

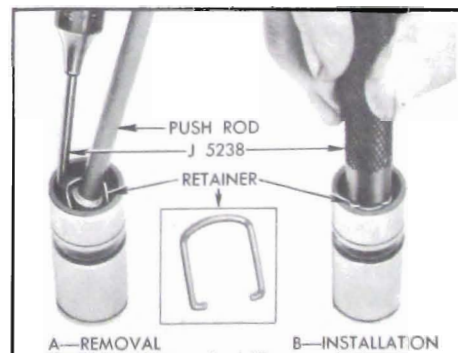

Figure 2-41—Removing and Installing Plunger Retainer

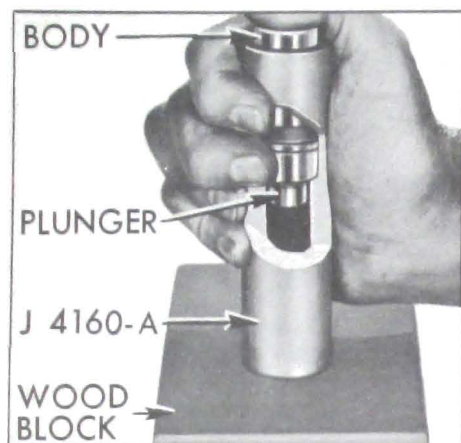

Figure 2-42—Removing Stuck Plunger with J-4160

3. Place all parts of each lifter in a separate compartment of a tray from Cleaning Tank J-5821. The body and plunger are selectively fitted to each other and must not be interchanged with parts of other lifters. Keeping all parts of the lifter together until cleaned and inspected will aid in diagnosing cause of improper operation.

4. Rinse the tray full of lifter parts in a pan of kerosene to remove as much oil as possible. This will reduce contamination of the cleaning solvent and extend its effective life.

5. Submerge the tray and parts in the cleaning solvent in left hand compartment of Cleaning Tank J-5821 and leave to soak for approximately one hour. The time required will depend on the varnish on lifter parts and the effectiveness of the solvent.

6. After the varnish has dissolved or has softened sufficiently to permit removal by wiping, raise the tray and suspend it above the solvent by means of the hooks on tray handles. Allow tray and parts to drain so that solvent will be saved.

7. Rinse the tray of parts in the pan of kerosene to cut the solvent and avoid injury to hands, then

place tray on the tank cover located on bench in front of cleaning tank.

8. Working on one lifter at a time and using CLEAN lint-free cloths, thoroughly wipe off all parts. Clean the plunger and the external and internal surfaces of the body with a hard wiping action to remove any varnish deposits. Rinse the parts in the kerosene contained in the middle compartment of cleaning tank, using Cleaning Brush J-5099 in the bore of lifter body.

NOTE: To insure absolute cleanliness of a reconditioned lifter assembly, it is advisable to inspect and assemble each lifter (subpara. d, e, f) before cleaning the next lifter.

d. Inspection of Hydraulic Lifter Parts

(1) Lifter Body. Inspect inner and outer surfaces of body for blow holes and scoring. Replace lifter assembly if body is roughly scored or grooved, or has a blow hole extending through the wall in position to permit oil leakage from lower chamber. The prominent wear pattern just above lower end of body should not be considered a defect unless it is definitely grooved or scored; it is caused by side thrust of cam against body while the lifter is moving vertically in its guide.

Inspect the cam contact surface on lower end of lifter body. Replace the lifter assembly if this surface is excessively worn, galled, or otherwise damaged. A lifter body that has been rotating will have a round wear pattern and a non-rotating lifter body will have a square wear pattern with a very slight depression near the center.

Either condition is normal and such bodies may be continued in use if the surface is free of defects. See Figure 2-43.

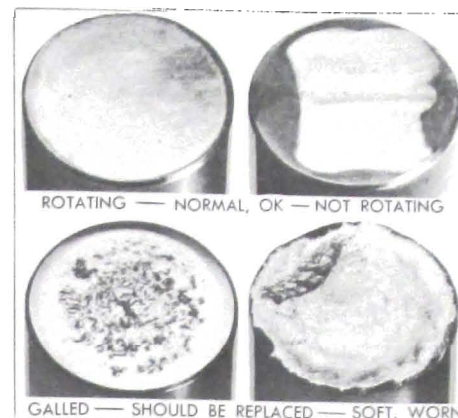

Figure 2-43—Lifter Body Wear Patterns

(2) Lifter Plunger. Using a magnifying glass, inspect the check ball seat for defects. Inspect outer surface of plunger for scratches or scores. Small score marks with a rough, satiny finish will cause the plunger to seize when hot but operate normally when cool. Defects in check ball seat or scores or scratches on outer surface of plunger which may be felt with a fingernail are causes for replacing the lifter assembly. This rule does not apply to the slight edge which may sometimes be present where the lower end of plunger extends below the ground inner surface of the body. This edge is not detrimental unless it is sharp or burred.

A blackened appearance is not a defective condition. Sometimes the discoloration serves to highlight slight grinder chatter marks and give the outer surface of plunger a ridged or fluted appearance. This condition will not cause improper operation, therefore it may be disregarded.

(3) Push Rod and Seat. Replace the push rod seat if the area where the push rod contacts is rough or otherwise damaged. Replace any push rod having a rough or damaged ball end.

(4) Check ball. Using a magnifying glass, carefully examine the check ball for nicks, imbedded

material or other defects which would prevent proper seating. Such defects would indicate the cause of intermittently noisy lifter operation. Even though no defects are found it is always advisable to discard the old ball and use a new one when reassembling the lifter.

(5) Check Ball Spring. Examine check ball spring for wear or damage. Replace any spring that is distorted or shows evidence of wear.

(6) Ball Retainer. Replace a retainer which is cracked or which has a heavily pounded area between the two holes. A small bright spot where the ball contacts the retainer is the normal condition.

(7) Plunger Spring. Replace the plunger spring only if it is distorted or damaged. Exhaustive tests have shown that plunger springs seldom break down in service.

e. Assembly of Hydraulic Lifters

All parts must be absolutely clean when a hydraulic lifter is assembled. Lint and dust may adhere to the parts if they are blown off or wiped with cloths; therefore they should be rinsed in CLEAN kerosene and assembled without drying.

1. Rinse lifter plunger in the kerosene in middle compartment of cleaning tank and then give it a thorough final rinsing in the kerosene in right compartment.

2. Hold plunger in vertical position with feed hole up, then rinse and install the check ball, check ball spring, ball retainer, spring, and body over the plunger. See parts in Figure 2-44.

3. Rinse push rod seat and plunger retainer, place these parts in end of body and depress

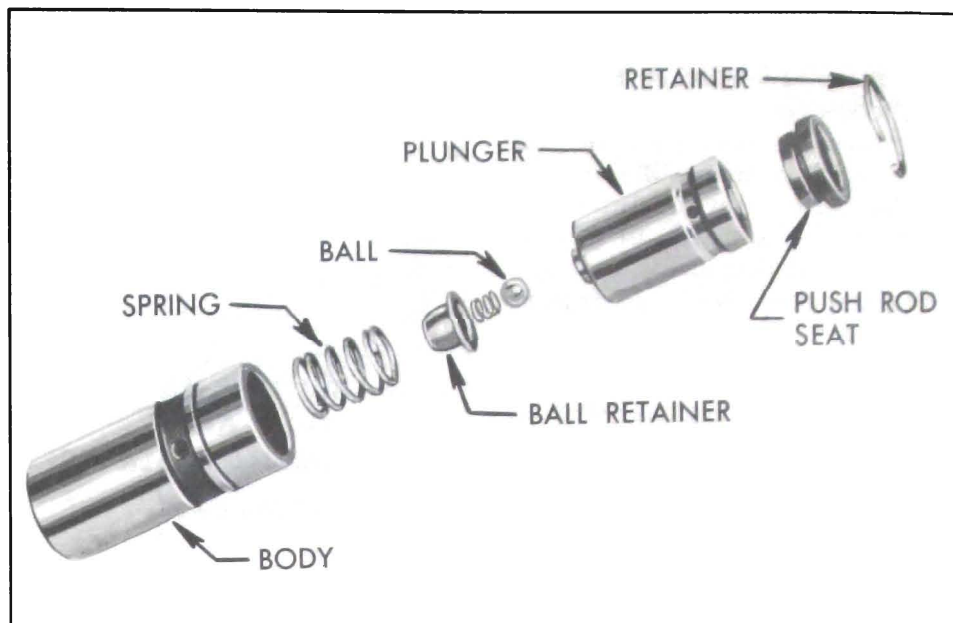

Figure 2-44—Hydraulic Valve Lifter Parts

with handle of Remover J-5238 until retainer engages groove in body. See Figure 2-41, View B.

4. Wrap the lifter in clean paper or otherwise protect it from dirt while reconditioning the other valve lifters, preparatory to testing all lifters for leakdown rate.

f. Testing Lifter Leakdown Rate

After a hydraulic lifter has been cleaned, inspected, and assembled it must be tested before it is installed in an engine. Lifter Test Fixture J-5790 has been designed to test the leakdown rate of a lifter to determine whether it is within limits which assure satisfactory lifter operation.

The following procedure must be carefully followed to obtain an accurate test.

1. Thoroughly clean the cup of test fixture, install cup on fixture, and fill it to within 1/2" of the top with "Hydraulic Lifter Test Fluid," which is available through Kent-Moore Organization, Inc., under K-M number J-5268.

2. Remove rubber washer (used for larger lifters) and install

Gauge Sleeve J-5180-5 in the cup; also install Buick V-8 Gauge Rod Nose J-5180-15 in the ram.

3. Swing the weight arm up out of the way, raise the ram and place the valve lifter (top side up) in Sleeve J-5180-5. The lifter must be completely covered by the fluid during test.

4. Lower the ram to rest in the lifter push rod seat, then lower the weight arm to rest on the roller of ram as shown in Figure 2-45.

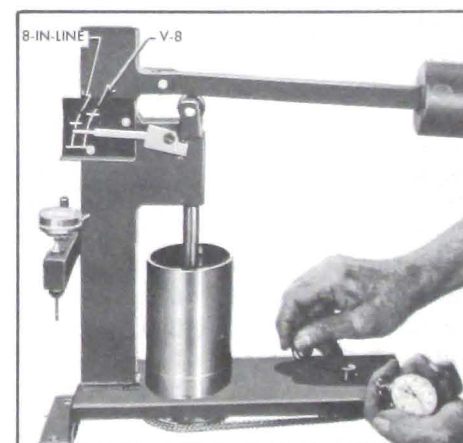

Figure 2-45—Checking Leakdown Rate

5. Operate the lifter plunger through its full travel to force all air out of the lifter by using a vigorous pumping action on the weight arm. Continue the pumping action until considerable resistance is built up in the lifter and a definite grab point is felt at the top of the stroke, when the indicator pointer is at the bottom of the scale.

Finally, pump vigorously for approximately 10 additional strokes to make sure all air is removed from the lifter. NOTE: If one stroke offers noticeable weak resistance during the last 10 pumping strokes replace the check ball in lifter and repeat the leakdown test to this point.

6. Raise weight arm to allow the lifter plunger to come up to its retainer, then lower the arm to rest on the ram roller. As the pointer starts moving upward start rotating the fluid cup by turning the handle one revolution every two seconds. See Figure 2-45.

7. Use a stop watch to check the time required for pointer to move from the lower to the upper mark on scale where marked "BUICK V-8." The cup must be rotated during this test. See Figure 2-45.

8. The leakdown rate (time between marks) must be between 12 and 40 seconds to assure satisfactory lifter performance. A doubtful lifter should be tested three or four times. Replace any lifter which does not test within the specified limits.

9. After all lifters have been tested, place the cover over the test fixture to keep dirt out of the cup and fluid. The fluid should be discarded and the cup should be thoroughly cleaned after a few sets of lifters have been tested.

g. Installation of Valve Lifters

Make certain that valve lifter guide holes and adjacent area of

cylinder block are clean, then liberally lubricate the cam shaft and lifter bores with "service MS" oil and install valve lifters. Each lifter must slide freely in its guide hole; if a lifter is tight in one guide hole fit it to another hole.

Complete the installation of all parts by reversing the procedure for removal.

2-16 TIMING CHAIN, COVER AND CAMSHAFT SERVICE

a. Timing Chain Cover Removal

1. Drain radiator and block.
2. Disconnect upper radiator hose and heater return hose at water pump, disconnect lower radiator hose. Remove attaching bolts and brackets and remove radiator core.
3. Remove fan, fan pulleys and belt(s).
4. Remove fan driving pulley (crankshaft) and pulley reinforcement.
5. Remove harmonic balancer to crankshaft bolt and washer 15/16" socket. Remove harmonic balancer. It may be necessary to tap the balancer with a plastic mallet to start it off the crankshaft.
6. If car is equipped with power steering, remove steering pump bracket bolts attached to timing chain cover and loosen or remove other bolts to allow the brackets and pump to be moved out of the way.

7. Disconnect fuel lines and remove fuel pump.

8. Remove Delcotron generator and brackets.

9. Remove distributor cap and pull spark plug wire retainers off brackets on rocker arm cover. Swing distributor cap with wires attached out of the way. Disconnect distributor primary lead.

10. Remove distributor. If timing chain and sprockets are not going to be disturbed, note position of distributor rotor for reinstallation in same position.

11. Loosen and slide front clamp on thermostat by-pass hose rearward.

12. Remove bolts attaching timing chain cover to cylinder block. Remove two oil pan to timing chain cover bolts. Remove timing chain cover assembly and gasket. Thoroughly clean the cover, taking care to avoid damage to the gasket surfaces.

b. Crankshaft Oil Seal Replacement

1. Use a punch to drive out old seal and shedder. Drive from the front toward the rear of the timing chain cover.
2. Coil new packing around opening so ends of packing are at top. Drive in new shedder using suitable punch. Stake the shedder in place in at least three places.
3. Size the packing by rotating a hammer handle or similar smooth tool around the packing till the balancer hub can be inserted through the opening.

c. Timing Chain Cover Replacement

Reinstall timing chain cover by reversing removal procedure, paying particular attention to the following points.

1. Remove oil pump cover and pack the space around the oil pump gears completely full of petroleum jelly. There must be no air space left inside the pump. Reinstall cover using new gasket. See Figure 2-70, paragraph 2-24. This step is very important as

the oil pump may "lose its prime" whenever the pump, pump cover or timing chain cover is disturbed. If the pump is not packed, it may not begin to pump oil as soon as the engine is started.

2. The gasket surface of the block and timing chain cover must be smooth and clean. Use a new gasket and be certain it is positioned correctly.

3. Position timing chain cover against block and be certain dowel pins engage dowel pin holes before starting bolts.

4. Lube the bolt threads before installation and install them as shown in Figure 2-46.

NOTE: If the car is equipped with power steering the front steering pump bracket should be installed at this time.

5. Lube the O.D. of the harmonic balancer before installation to prevent damage to the seal during installation and when the engine is first started.

d. Timing Chain and Sprocket Removal

1. With timing chain cover removed (subpar. a above) temporarily install harmonic balancer bolt and washer in end of crankshaft. Turn crankshaft so sprockets are positioned as shown in Figure 2-47. Doing so will make it easier to reinstall parts. Remove harmonic balancer bolt and washer using a sharp rap on the wrench handle to start the bolt out without changing position of sprockets.

NOTE: It is not necessary to remove timing chain dampers on V-6 engines unless they are worn or damaged and require replacement.

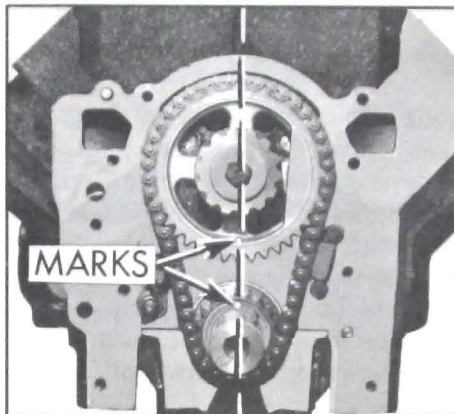

Figure 2-47—Timing Chain and Sprockets Properly Installed - V-6 Shown

2. Remove front crankshaft oil slinger.

3. Remove bolt and special washer retaining camshaft distributor drive gear and fuel pump eccentric to camshaft forward end. Slide gear and eccentric off camshaft.

4. Use two large screwdrivers to alternately pry the camshaft sprocket then the crankshaft sprocket forward until the camshaft sprocket is free, then remove the camshaft sprocket and chain and finish working crankshaft sprocket off crankshaft.

5. Thoroughly clean the timing chain, sprockets, distributor drive gear, fuel pump eccentric and crankshaft oil slinger.

e. Timing Chain and Sprocket Installation

1. Turn crankshaft so number one piston is at top dead center.

2. Turn camshaft so with sprocket temporarily installed, timing mark is straight down. See Figure 2-47. Remove sprocket.

3. Assemble timing chain on

sprockets and slide the sprocket and chain assembly on the shafts with the timing marks in their closest together position and in line with the sprocket hubs. See Figure 2-47.

NOTE: It will be necessary to hold spring loaded timing chain damper out of the way while sliding chain and sprockets into position.

4. Assemble slinger on crankshaft with I.D. against sprocket. (Concave side toward front of engine).

5. Slide fuel pump eccentric on camshaft and Woodruff key with oil groove forward. See Figure 2-48.

6. Install distributor drive gear. See Figure 2-48.

7. Install drive gear and eccentric bolt and retaining washer. Torque to 40-45 ft. lbs.

8. Reinstall timing chain cover (subpar. c above).

f. Camshaft Replacement

1. Remove rocker arm and shaft assemblies, push rods and valve lifters. Paragraph 2-14, subparagraph a, Step 3.

2. Remove timing chain cover, timing chain and sprocket subparagraphs a and d above.

3. Slide camshaft forward out of bearing bores carefully to avoid marring the bearing surfaces.

4. Replace camshaft by reversing removal procedure, taking particular care to avoid damage to the camshaft bearings.

g. Camshaft Bearings

The steel-backed babbitt-lined camshaft bearings are pressed into the crankcase. Going from front to rear, each bearing is bored .030" smaller than the preceding bearing, and each camshaft journal is correspondingly reduced in diameter.

The camshaft bearings must be line reamed to size after being

pressed into the crankcase. Since this operation requires special reaming equipment the original bearings should be retained unless severely damaged. Slightly scored camshaft bearings will be satisfactory if the surfaces of camshaft journals are polished and bearings are cleaned up to remove burrs, and the fit of shaft in bearings is free and within the clearance limits of .0015" to .004".

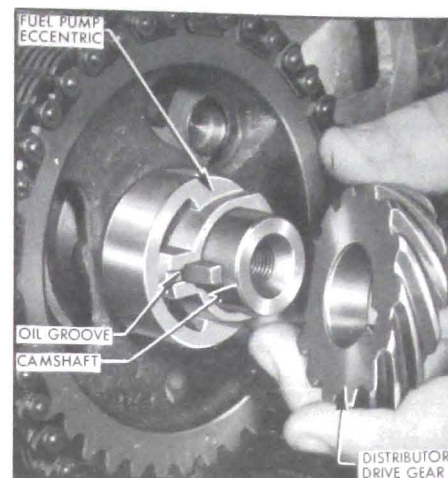

Figure 2-48—Fuel Pump Eccentric and Distributor Drive Gear Installation