

**SECTION 4-B
SYNCHROMESH TRANSMISSION**

CONTENTS OF SECTION 4-B

Paragraph	Subject	Page	Paragraph	Subject	Page
4-7	S-M Transmission Specifications	4-8	4-12	Removal and Installation of S-M Transmission	4-14
4-8	S-M Transmission Description	4-8	4-13	Disassembly of S-M Transmission	4-17
4-9	S-M Transmission Shift Control Mechanism	4-11	4-14	Cleaning and Inspection of Transmission Parts	4-20
4-10	S-M Transmission Trouble Diagnosis	4-13	4-15	Assembly of Transmission Assembly	4-20
4-11	Adjustment of S-M Transmission Shift Controls	4-14			

NOTE: Synchromesh transmission is standard and automatic transmission and 4-speed transmissions optional on Series 4000-4100.

4-7 S-M TRANSMISSION SPECIFICATIONS

a. Tightening Specifications

Part	Location	Thread Size	Torque Ft. Lbs.
Bolt	Front Companion Flange to Transmission Main Shaft	3/8 -24	45-55
Nut	Shift Lever to Shaft	3/8 -24	15-20
Bolt	Flywheel Housing to Crankcase	3/8 -16	30-35
Bolt	Transmission to Flywheel Housing	7/16-14	40-45

b. S-M Transmission Specifications

Mounting	Unit with Engine
Oil Capacity, Pints	2 1/4
Type of Gearing	All Helical
Transmission Ratio -	
In Third	Direct
In Second	1.55 to 1
In First	2.57 to 1
In Reverse	3.49 to 1
Blocking Ring to Drive Gear Clearance045" Min.
Blocking Ring to Second Speed Gear Clearance045" Min.
Counter Gear End Clearance005" - .017"
Interlock Sleeve to Cam Clearance001" - .007"
Second Speed Gear End Clearance003" - .016"

c. Speedometer Gears

Speedometer Worm on Main Shaft	Slip Fit
Teeth on Worm (Synchromesh)	7
Teeth on Worm (Automatic)	8
Teeth on Driven Gear (Synchromesh - 3.36 Axle Ratio)	19 (Blue)
Teeth on Driven Gear (Automatic - 3.08 Axle Ratio)	20 (Red)

4-8 S-M TRANSMISSION DESCRIPTION

The synchromesh transmission is solidly bolted to the rear face of the flywheel upper

housing, to form a unit assembly with the engine. The transmission drive gear shaft extends through the clutch driven plate into a

bronze bushing seated in the rear end of the engine crankshaft. The front bearing retainer projects into a bore in the flywheel housing, serving as a pilot to center the transmission with the engine crankshaft.

a. Transmission Gears and Shafts

The transmission main drive gear is supported by a ball bearing which is a slip fit in the front wall of the transmission case. The ball bearing is shielded on the rear side by a slinger washer. This washer is held tight against a shoulder on the drive gear by the bearing pressed against it. The bearing is prevented from moving away from the washer by a selective fit snap ring in a groove in the drive gear shaft. The outer race of the bearing is grooved for a snap ring which fits between the transmission case and the front bearing retainer to hold the bearing and main drive gear in place. See Figure 4-7.

The front end of the transmission main shaft is piloted in the bored rear end of the main drive gear by 14 loose rollers. The rear end of the main shaft is supported by the transmission rear bearing which is a slip fit in the rear wall of transmission case. The outer race of the rear bearing is grooved for a snap ring which fits between the transmission case and the rear bearing retainer. The inner race of the bearing is retained between a shoulder on the main shaft and a snap ring in a groove in the shaft.

The transmission counter gear is supported by a set of 22 needle rollers on each end of the counter shaft. The counter shaft is held in position by its tight fit in the forward hole and by a lock plate between it and the reverse idler gear shaft. A tubular spacer separates the two sets of rollers and two washer-type spacers are located at the outer ends of each set to hold the rollers in position. End thrust is taken by a single thrust washer in the front and two thrust washers in the rear. A hole in the hub of the counter gear permits lubricant to reach the bearings and thrust washers.

The reverse idler gear is provided with a bronze bushing and is supported on a shaft which is held stationary by a lock plate between it and the counter shaft. End clearance of the gear permits lubricant to reach the bushing. The second speed gear is provided with a bronze bushing and is mounted on the main shaft in such a position that it is in constant

mesh with the counter gear. It is held in position between the front shoulder of the first-reverse gear splines and the hub of the synchronizer assembly. The gear is free to rotate on the main shaft except when engaged by the synchronizing assembly during second speed operation. See Figure 4-8.

The first-reverse sliding gear is splined to the main shaft to the rear of the second speed gear so that it can be moved forward to engage the counter gear for first speed or rearward to engage the reverse idler for reverse.

b. Gear Shift and Synchronization

The synchronizing assembly and the first-reverse gear are actuated by the shift mechanism. The gear shift mechanism is described in paragraph 4-9. The synchronizing assembly is splined to the main shaft to transmit drive when the assembly is engaged with either the drive gear (third speed) or the second speed gear. The synchronizing assembly includes a hub, sleeve, shift plates, springs and blocking rings which act to synchronize the speed of the gear to be engaged with the speed of the hub during a shift into either second or third speed. As the sleeve moves toward the gear to be engaged, the shift plates press the blocking ring into contact with the gear, after which the springs allow the shift plates to slide out of the detent notches in the sleeve to permit the sleeve to engage the gear quietly and easily.

c. Speedometer Gears

The speedometer driving worm gear is held against a shoulder on the transmission main shaft by forward pressure of the front companion flange. When changing rear axle ratios it is only necessary to change the driven gear because the same driving worm gear is used for all ratios. The speedometer driven gear assembly consists of a sleeve, a gear and shaft, an O-ring sleeve seal, a sleeve retainer and bolt. The driven gear sleeve is a slip fit in the rear bearing retainer. The sleeve is held in place by a retainer which fits into a slot in the sleeve and is bolted to the rear bearing retainer. The gears are lubricated by splash from the transmission. The speedometer cable is attached to the sleeve by a threaded sleeve on the cable casing.

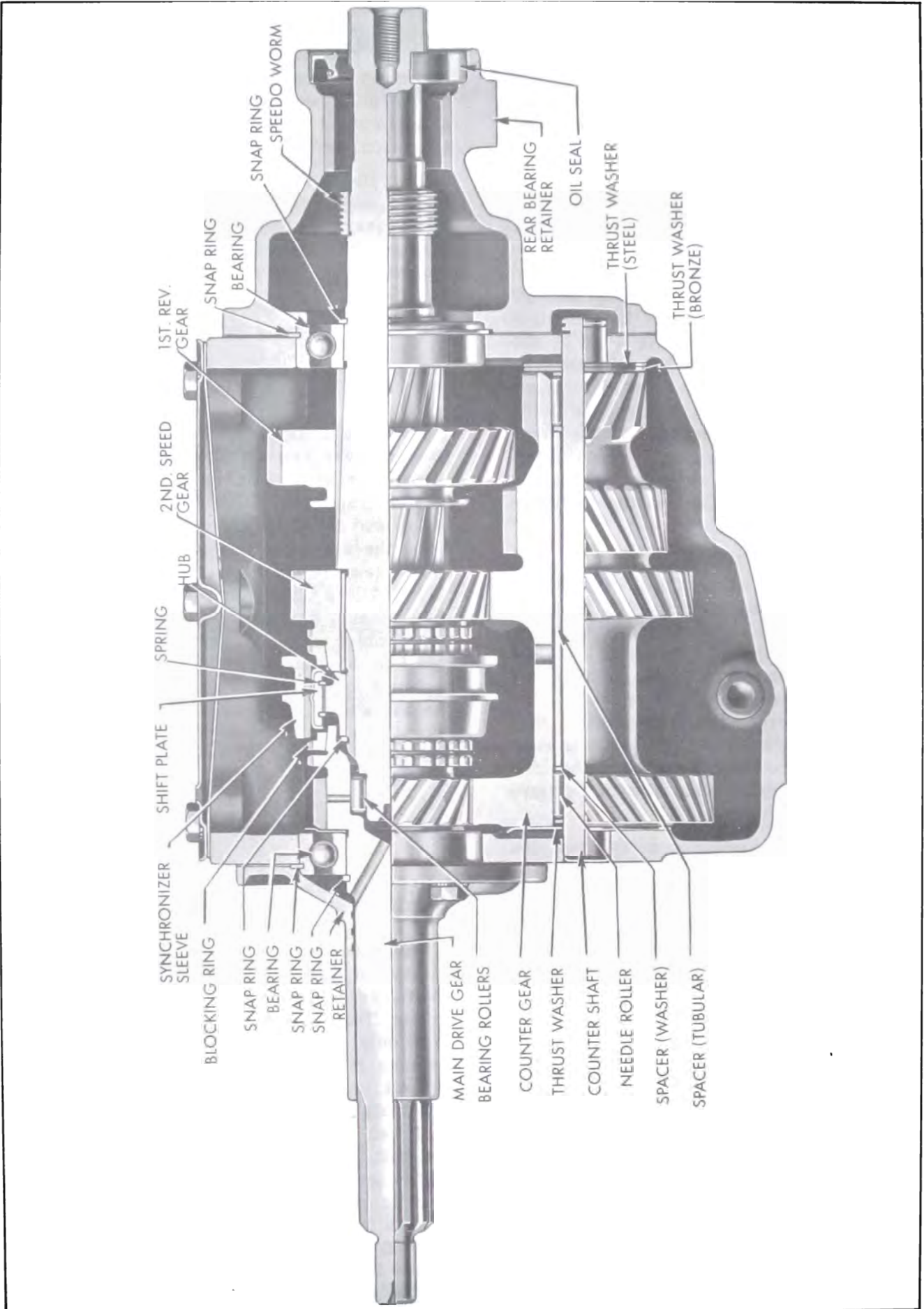

Figure 4-8-Synchronesh Transmission

d. Universal Joint

The universal joint is splined to the rear end of the transmission main shaft and is retained by a heavy steel washer and bolt. The length of the front companion flange is such that it bottoms against the speedometer drive gear. An oil seal is located in the rear end of the rear bearing retainer with the seal lip contacting the companion flange.

e. Shift Linkage Equalizer

An equalizer lever is pivoted between the second-third shift lever nut and a bracket mounted on the body side rail. A shift rod from the transmission control shaft lever actuates the equalizer lever which in turn engages the second-third shift lever. This equalizer allows operation of the transmission in second and third with little or no effect from relative motion between the engine - transmission assembly and the body. See Figure 4-10.

f. Power Flow Through Transmission

1. In first speed, the first speed sliding gear is slid forward on the mainshaft splines so that it engages its corresponding gear on the counter gear. See Figure 4-9 to follow the power flow.

2. In second speed, the clutch sleeve is slid rearward on the synchronizer hub so that it first synchronizes the speed of the second gear, then engages the projecting teeth on the second gear. See Figure 4-9.

3. In third speed, the clutch sleeve is slid forward on the synchronizer hub so that it first synchronizes the speed of the drive gear, then engages the projecting teeth on the drive gear. See Figure 4-9.

4. In reverse, the first-reverse gear is slid rearward on the mainshaft splines so that it engages the reverse idler, which is in constant mesh with a corresponding gear on the counter gear. The idler gear reverses the direction of rotation of the complete drive train in the rear of the reverse idler.

4-9 S-M TRANSMISSION SHIFT CONTROL MECHANISM

Both shift levers are located on the left side

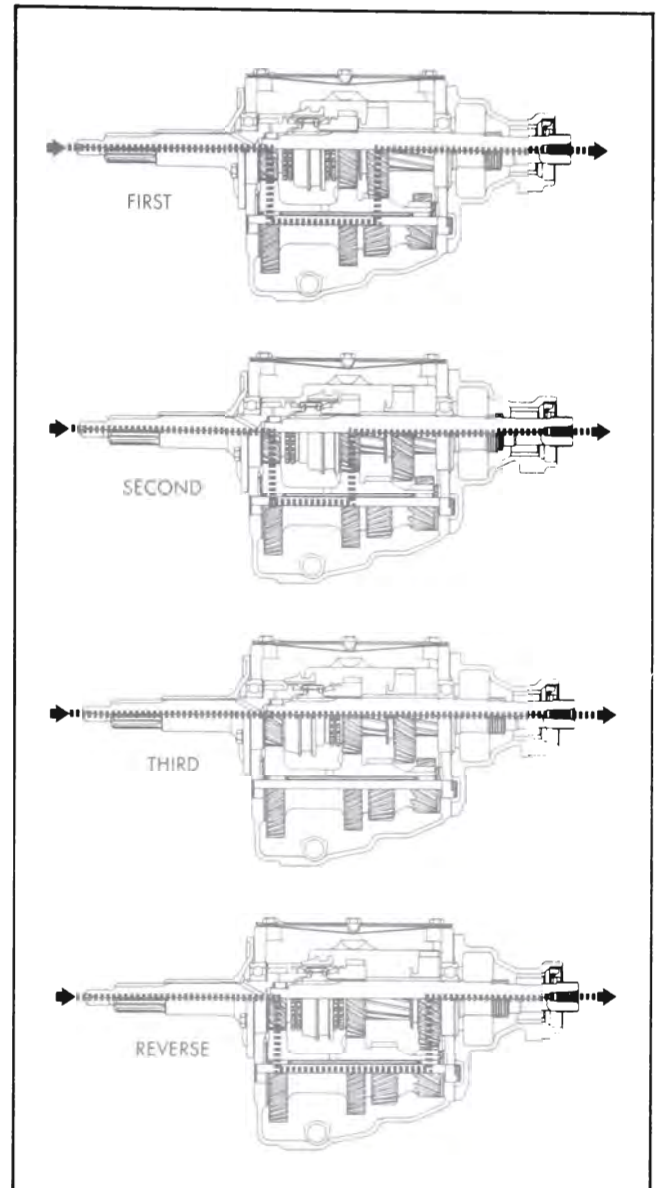

Figure 4-9—Power Flow Through Transmission

of the transmission. The forward lever controls the second-third shift; the rear lever controls the first-reverse shift.

When the second-third shift lever is moved forward by the equalizer lever, a shift shaft with an integral notched cam is rotated to cause a shift fork to move rearward. This moves the clutch sleeve rearward to first synchronize the speed of the second gear and then to engage the projecting teeth on the second gear. When the second-third lever is moved rearward, the notched cam is rotated in the other direction and the clutch sleeve is moved forward to first synchronize the speed of the drive gear and then to engage the projecting teeth on the drive gear. See Figure 4-10.

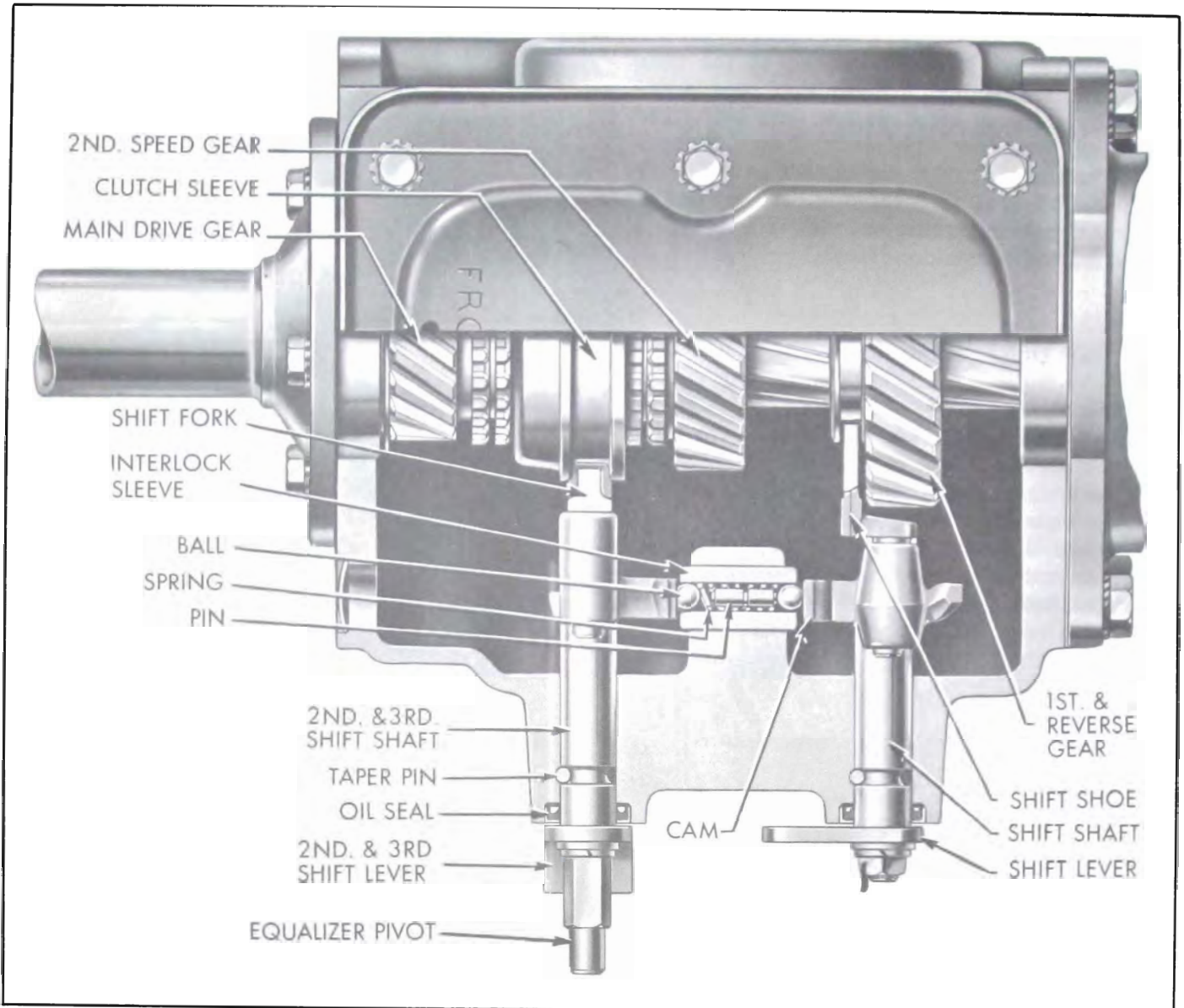

Figure 4-10—Transmission Shift and Interlock Mechanism

When the first-reverse lever is moved rearward, a shift shaft with an integral notched cam is rotated to cause a shift shoe to move forward. This moves the first-reverse gear forward to engage its corresponding part on the counter gear. When the first-reverse lever is moved forward, the notched cam is rotated in the other direction and the first-reverse gear is moved rearward to engage the reverse idler gear. See Figure 4-10.

When either shift lever is moved from the center or neutral position, an interlock mechanism located between the second-third shift cam and the first-reverse shift cam prevents the other shift lever from being moved from its neutral position. This prevents the pos-

sibility of shifting into two gears at once, which would lock-up the transmission.

The interlock mechanism consists of an interlock sleeve, pin, spring and two balls. Each shift shaft cam has three grooves into which the interlock spring pushes the balls; these detents make a definite position for each shift. Each cam is lower in the center or neutral position and higher each side of the neutral position. When either cam is shifted out of the neutral position, the interlock sleeve is slid over so that it almost touches the other cam which is in the neutral position. The interlock sleeve therefore prevents this other cam from being shifted out of its neutral position unless the first cam is returned to neutral. See Figure 4-10.

4-10 S-M TRANSMISSION TROUBLE DIAGNOSIS

a. Hard Shifting and Block-out

Hard shifting may be caused either by conditions in the shift control mechanism or by conditions in the transmission assembly. Disconnect the shift rods at the control shaft levers to determine which is at fault.

b. Low and Reverse Gear Clash

Transmission gears can be made to clash by shifting into first or reverse gear too quickly after the clutch pedal is depressed, even though clutch is in perfect working order. This is because inertia of the clutch driven plate, drive gear and counter gear causes these parts to spin until stopped by friction of the transmission and transmission lubricant. With warm transmission lubricant and low friction transmission bearings, a reasonable amount of spin is to be expected. The clash does not occur when shifting quickly into second or high gear with the car standing still because the synchronizing unit stops the spinning parts.

To eliminate gear clash, sufficient time **MUST** be allowed before shifting into first after the pedal is depressed or else starts must be made in second gear. There is no objection to making starts in second gear on level ground since the clutch slippage under ordinary driving conditions is not sufficient to produce enough heat to damage the driven plate facings.

If gear clash continues after allowing proper time for the clutch driven plate parts to stop, check the clutch pedal lash and adjust to specified limits. See paragraph 4-4. Make sure that the idle speed of the engine when hot is 525 RPM. A faster idle aggravates driven plate spinning.

Conditions within the transmission which may cause gear clash are: (1) Faulty blocking rings or cone surfaces; (2) Excessive main shaft end play; (3) Weak or broken detent springs in the synchronizing hub. Gear clash also may be caused by a dragging clutch plate.

c. Noise in Neutral

With the car standing, engine running, and transmission in neutral, the transmission parts in operation are; main drive gear and bearing, counter gear and bearings, reverse idler gear,

second speed gear. Disengaging the clutch will stop movement of all these parts. By disengaging and engaging the clutch it can be determined whether the noise originates in these transmission parts and whether the noise is normal. Noise in neutral in the form of a constant regular click is usually caused by a nicked gear or bearing.

d. Gear Noise

Some gear noise is to be expected in all except third speed. Comparison with another car is the only means of determining whether or not gear noise is excessive. Before moving the transmission for correction of gear noise, determine by test which gears are noisy under load, so that these parts can be thoroughly inspected when removed.

e. Gear Rattle During Acceleration

An improperly calibrated clutch driven plate, a faulty crankshaft balancer, or scored rear axle gears may cause rattle in the transmission in third speed on acceleration. Rattles occurring on wide open throttle between 40 and 60 MPH are usually caused by improper clutch driven plate dampening; a new driven plate should be installed if rattles are objectionable.

f. Noise When Shifting out of First or Reverse

Shifting out of first or reverse very slowly will usually result in some noise just as the gears disengage. This is normal because of the gear pointing necessary for easy engagement.

Abnormal noise during a normally fast shift may be caused by improper clutch release. Check clutch pedal lash and adjust. See paragraph 4-4.

Abnormal noise during a normally fast shift, when clutch release is satisfactory, may be caused by damage to the pointing on the engaging side of the teeth on the counter gear, reverse idler gear or first - reverse sliding gear. Noise when disengaging both first and reverse indicates that the fault is with the sliding gear only. Noise when disengaging reverse only indicates that the reverse idler gear is at fault. Noise when disengaging first speed only indicates that the counter gear is at fault. Tests must be made by disengaging gears while car is still in motion.

g. Gear Jump-Out

In any case of gear jump-out, first check the adjustment of the gear shift control mechanism as described in paragraph 4-11. Make certain that interlock balls have full engagement in the notches in the shift shaft cam through all speed positions including neutral.

Gear jump-out in third speed may be caused by misalignment between the flywheel housing hole and the crankshaft.

Gear jump-out in any transmission speed position may be caused by loose fit of the bearings or bushings involved, a weak interlock spring, loose fit of the synchronizing hub on the main shaft, loose fit of the first-reverse gear on the main shaft, worn teeth on mating gears. All items should be carefully inspected.

h. Scored or Broken Gear Teeth

Gear teeth will be seriously damaged and possibly broken by failure of the car operator to fully engage the gears on every shift before engaging the clutch and applying engine power.

Considerable damage to gears and bearings may result from running at abnormal speeds in reverse, first and second speed gears. This practice is also detrimental to the engine.

4-11 ADJUSTMENT OF S-M TRANSMISSION SHIFT CONTROLS

Need for a shift control adjustment is indicated if either lower control shaft lever contacts the edge of the steering column jacket opening, or if the manual control lever does not move smoothly from the 2nd-3rd range into the 1st-reverse range when the lever is lifted straight toward the steering wheel.

1. Make certain that the shift equalizer is properly aligned and not binding. Check to see that the equalizer pin which is welded to the underbody side rail goes through the outboard side of the shift equalizer at right angles and that it is located in the center of the hole in the equalizer by the rubber washer. In order to adjust the alignment of this pin it is necessary to bend the bracket to the desired location. Care must be exercised to avoid breaking the weld.

2. Place transmission in neutral.

3. Loosen shift rod adjusting clamps. See fig. 4-12.

4. Loosen lever retainer ring bolt and install fixture J-8992 on mast jacket as shown in fig. 4-13.

5. Position second and third shift lever against fixture. Tighten second and third adjustment clamp with lever held against fixture. Torque to 10-12 ft. lbs.

NOTE: Over-torquing can cause hard shifting by binding swivel joint.

6. Next, move first and reverse shift rod until a good cross-over point is obtained. This is done by lifting shift control lever at steering wheel location several times until no interference is felt when moving lever from second-third to first-reverse neutral position. When the lever is released when in the first-reverse neutral position it should spring down to the second-third neutral position. Hold lever midway in this cross-over position and tighten adjusting clamp. Re-check for smooth cross-over position.

7. Remove fixture and retighten retainer ring bolt.

8. Tighten 2nd-3rd shift rod adjusting clamp.

9. Lift manual control lever from 2nd-3rd range straight toward steering wheel into 1st reverse range. Do this several times to align 1st-reverse lower control shaft lever, then tighten 1st-reverse shift rod adjusting clamp. See Figure 4-10.

10. To recheck adjustment, depress clutch and shift transmission into each gear to check lower control shaft lever clearance in steering column jacket opening. Make sure that the manual lever movement from 2nd-3rd range into 1st reverse range is smooth and easy.

4-12 REMOVAL AND INSTALLATION OF S-M TRANSMISSION

a. Removal of Transmission

1. If transmission is to be disassembled, drain transmission lubricant. Fill with kerosene and run transmission in neutral about 15 seconds. Drain kerosene.

2. Mark front universal joint and front companion flange so that these parts can be reassembled in same relative position. Remove

2 U-bolts attaching universal joint to front companion flange. Slide front propeller shaft rearward as far as possible for working clearance.

3. Disconnect shift linkage from transmission by first removing equalizer spring. Slide shift equalizer to full left position to disengage it from 2nd-3rd shift lever, then slide equalizer to right to remove from support pin. Remove transmission 1st-reverse shift lever

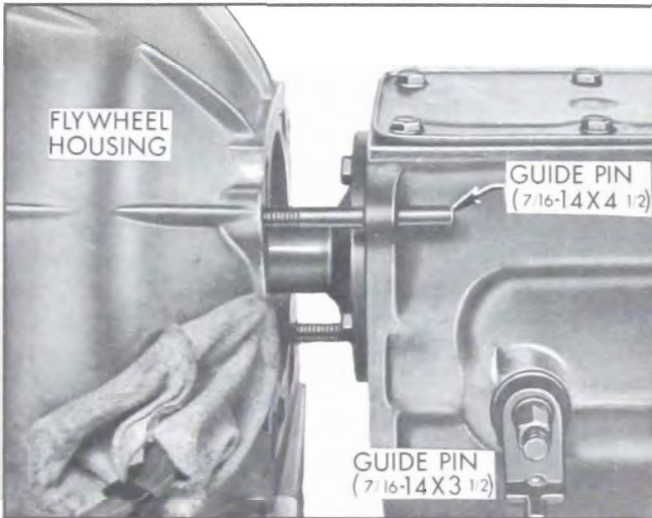

Figure 4-11—Transmission Guide Pins

from shift shaft. By disconnecting shift linkage in this way, shift linkage is not disturbed and should not require readjusting.

4. Disconnect speedometer cable from transmission.

5. Loosen all three exhaust pipe ball joints so that transmission and rear end of engine can be lowered.

6. Remove two bolts attaching transmission mounting pad to transmission support. Leave mounting pad bolted to transmission.

7. Place a flat wood block on jack. Jack under engine pan until transmission mounting pad just clears transmission support.

8. Remove four bolts attaching transmission support to body members. Remove support, then lower jack so that transmission will clear underbody during removal.

9. Remove upper left transmission to flywheel housing bolt and install a 7/16-14 x 4-1/2 inch guide pin; remove lower right bolt and install a 7/16-14 x 3-1/2 inch guide pin. See Figure 4-11.

10. Remove other two transmission to flywheel housing bolts. Slide transmission straight back until drive gear shaft is clear of flywheel housing, then lower transmission. **CAUTION: If weight of transmission is allowed to rest on main drive gear while drive gear splines are in clutch driven plate, driven plate may be damaged.**

b. Installation of Transmission

1. Lightly coat splines on end of main drive gear with Lubriplate for a distance of about 1 inch. Do not apply an excess that will push off at driven plate hub and get on clutch facings. Fill groove in inner surface of throw-out bearing with wheel bearing grease.

2. Make certain that front face of transmission case and rear face of flywheel housing are absolutely clean. Install a 7/16-14 x 4-1/2 inch guide pin in upper left flywheel housing hole; install a 7/16-14 x 3-1/2 inch guide pin in lower right hole. See Figure 4-11.

3. Shift transmission into 3rd gear. Lift transmission into place on guide pins and slide straight forward, meanwhile fully supporting transmission. Rotate companion flange as required to engage drive gear with driven plate splines. **CAUTION: If weight of transmission is allowed to rest on main drive gear shaft before shaft engages pilot bushing in flywheel, driven plate may be damaged.**

4. Install two transmission to flywheel housing bolts; remove guide pins and install other two bolts. Tighten all four bolts securely.

5. Raise jack under engine pan so that transmission mounting pad will clear transmission support.

6. Install transmission support, leaving four nuts loose. Lower jack so that transmission rests on support.

7. Install two bolts attaching mounting pad to support, then tighten all six bolts securely.

8. Align exhaust system, if necessary, and tighten three ball joints.

9. Connect speedometer cable to transmission.

10. Install 1st-reverse shift lever on transmission shaft and tighten nut securely. Install shift equalizer by first sliding left end of equalizer over support pin, then engaging right end of equalizer with 2nd-3rd shift lever. Install equalizer spring.

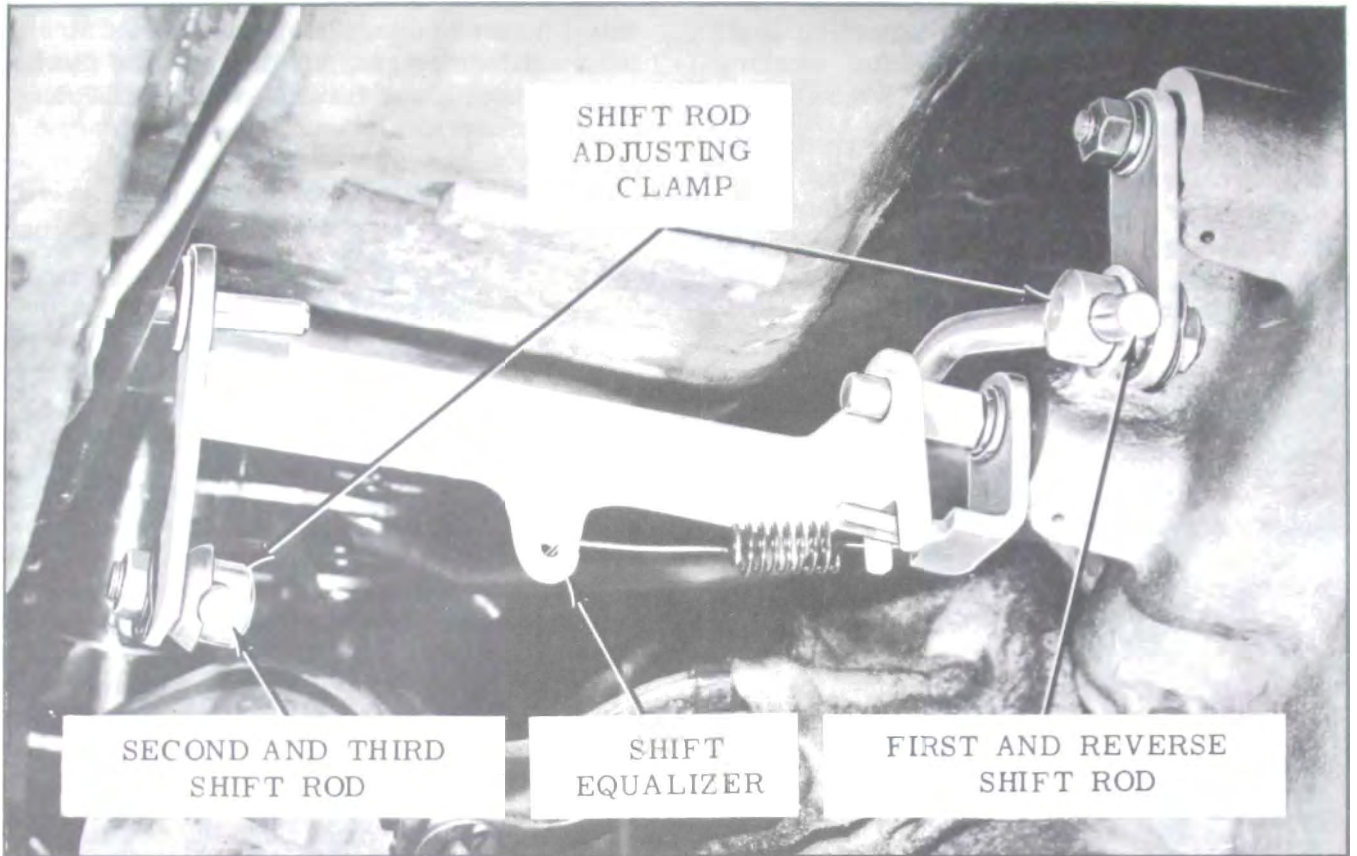

Figure 4-12—Loosening Shift Rod Adjusting Clamps

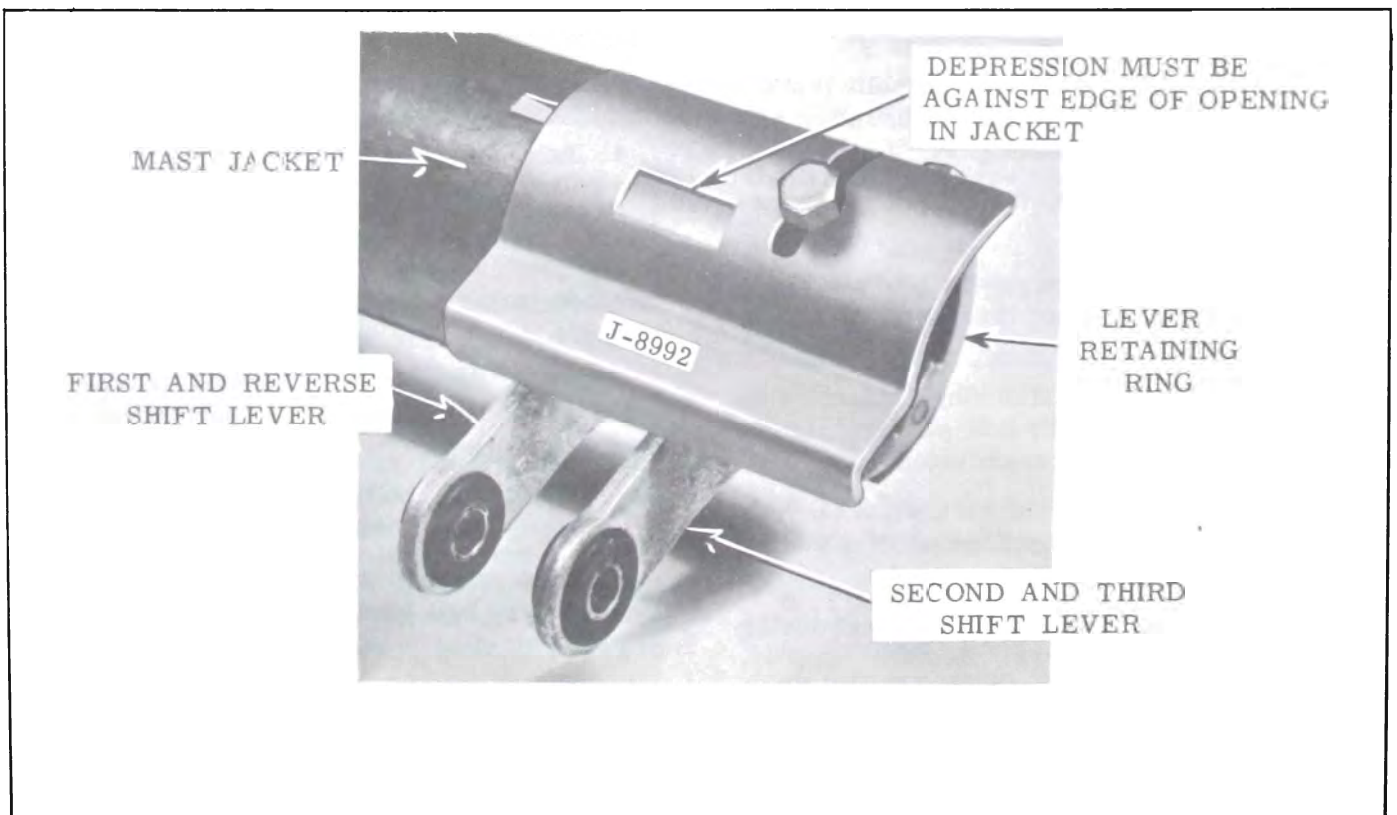

Figure 4-13—Installing J-8992

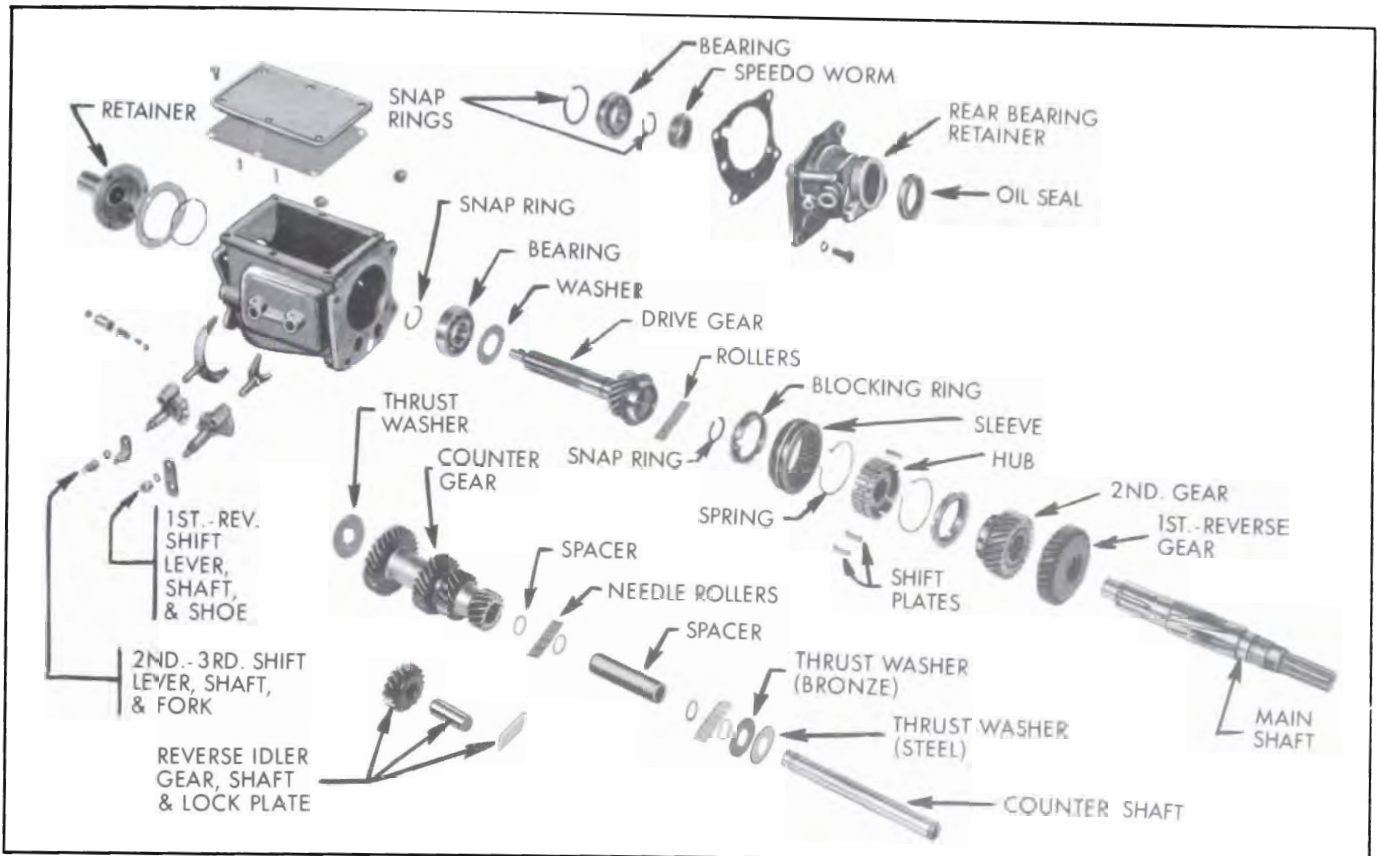

Figure 4-14—Synchromesh Transmission—Exploded

11. Align mark on front universal joint with mark on front companion flange. Install U-bolts and lock plates. If there is any doubt as to safety of lock plates, use new lock plates. Tighten nuts securely and bend up lock plate tabs. Make sure propeller shaft center bearing insulator is in position in support bracket.

12. Fill transmission with specified gear lubricant. See paragraph 1-4.

13. Check adjustment of shift linkage. See paragraph 4-11. Check adjustment of clutch linkage. See paragraph 4-4.

14. Road test car, checking for proper shifting, correct synchronization, and quiet operation.

4-13 DISASSEMBLY OF S-M TRANSMISSION

a. Disassembly of Drive Gear and Main Shaft Parts

1. Remove top cover and gasket. Cover and gasket are both stamped "FRONT" for installation in this position.

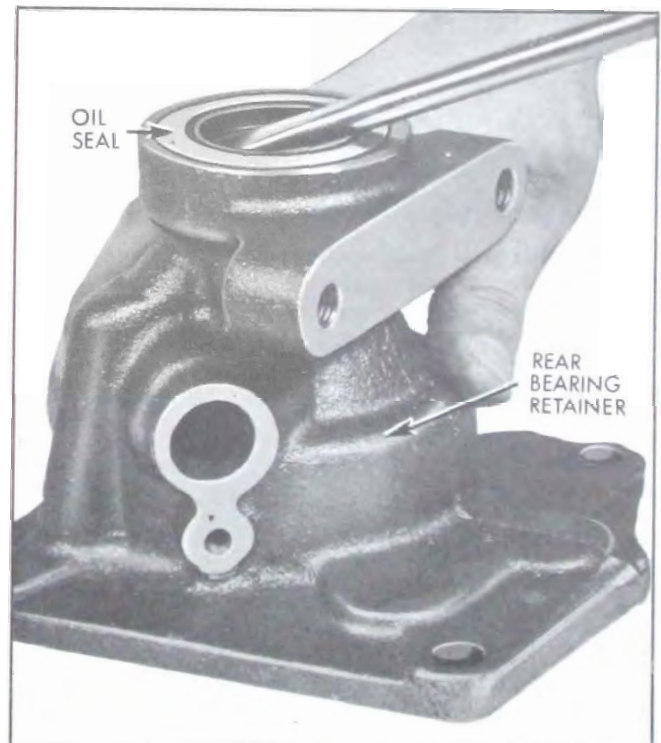

Figure 4-15—Removing Rear Bearing Retainer Oil Seal

2. Remove front bearing retainer and gasket. Note position of gasket—oil return groove in retainer must match notch in gasket during reassembly.

3. Remove retainer holding speedometer sleeve in rear bearing retainer. Remove driven gear and sleeve. O-ring seal can not be removed from driven gear sleeve. Assemble puller J-8614 as shown in Figure 4-15A and pull companion flange from main shaft.

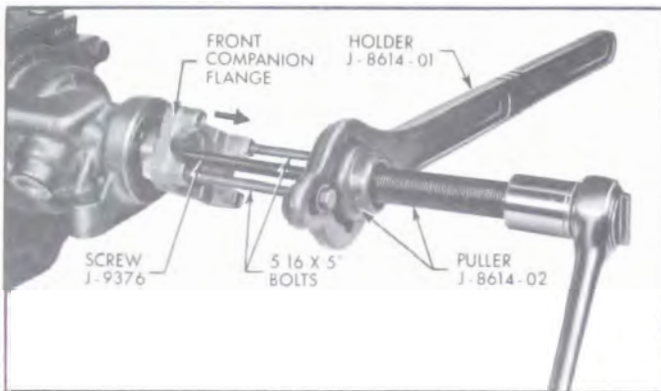

Figure 4-15A—Removing Front Companion Flange

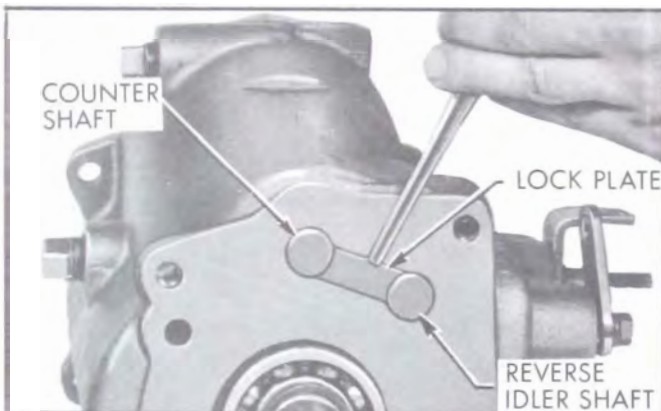

Figure 4-16—Removing Lock Plate

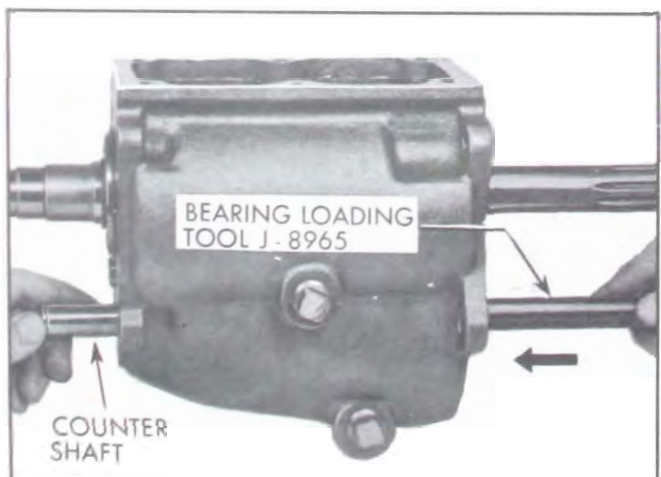

Figure 4-17—Installing Loading Tool J-8965

4. Remove rear bearing retainer and gasket. Remove speedometer worm gear from main shaft. Pry oil seal from retainer. See Figure 4-15.

5. Drive countershaft and reverse idler shaft lock plate from position. See Figure 4-16.

6. Drive countershaft rearward with a brass drift until shaft is just free in front shaft bore of case. Using Bearing Loading Tool J-8965, push out countershaft, making sure loading tool is tight behind countershaft at all times. Allow countergear to drop to bottom of housing with loading tool in place to keep bearing rollers and thrust washers intact. See Figure 4-17.

7. Remove main drive gear and bearing. Outer race of bearing is not held solidly in case bore, allowing drive gear and bearing to be removed by pulling shaft forward. Remove 14 bearing rollers from rear end of shaft.

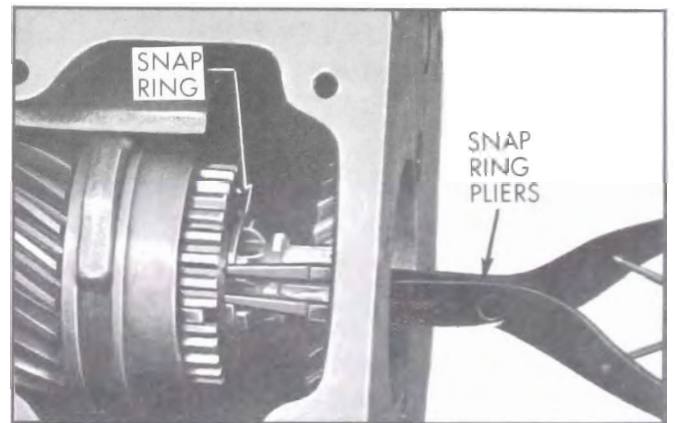

Figure 4-18—Removing Snap Ring from Front of Main Shaft

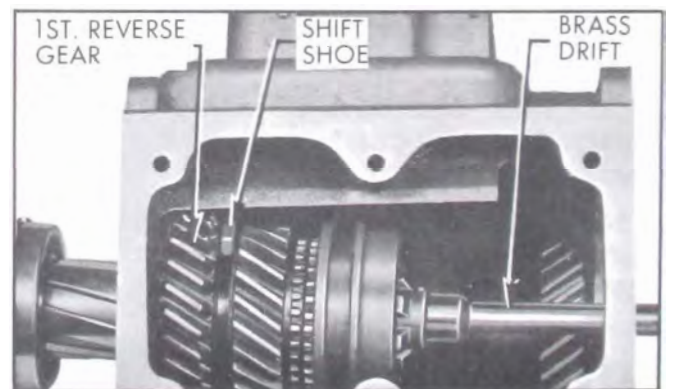

Figure 4-19—Removing Main Shaft

8. Remove front bronze blocking ring from synchronizer assembly. Remove snap ring from front of main shaft using suitable snap ring pliers. See Figure 4-18.

9. Move shaft rearward until rear bearing is free of case (outer race of bearing is not held solidly in case). Move shaft to extreme right in case. Remove second-third shift fork.

10. Remove main shaft by sliding shaft rearward through rear of case allowing synchronizer assembly, second speed gear, and first-reverse gear to slide off front of shaft. See Figure 4-19.

NOTE: If synchronizer assembly does not slide freely from shaft, move shaft to extreme

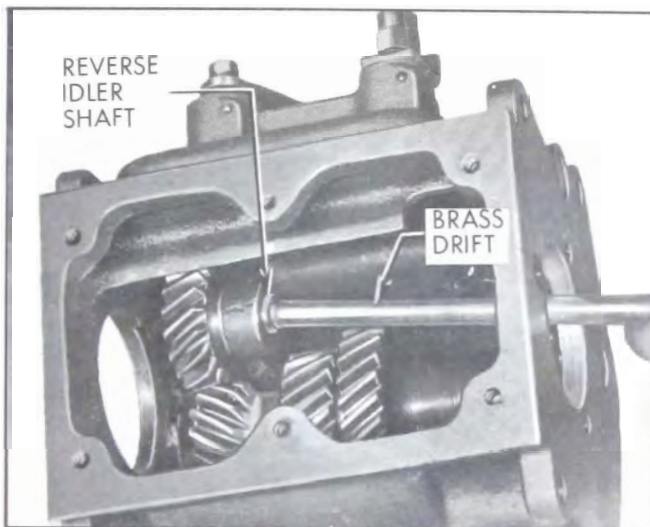

Figure 4-20—Removing Reverse Idler Shaft

right in case. Rotate first-reverse shift shoe to be offset toward rear. Move shaft back to original position with shift shoe in groove on first-reverse gear. Position first-reverse gear to solidly rest against rear of case and drive shaft rearward using a brass drift.

11. Remove first-reverse shift shoe from shift shaft. Drive reverse idler shaft out of rear of case using a brass drift. See Figure 4-20. Remove reverse idler gear.

12. With bearing loading tool in place, remove counter gear through top opening in case.

13. If bearings on main shaft and/or drive gear are to be replaced, remove shaft snap ring and drive bearing off shaft. See Figure 4-21. Remove slinger washer from drive gear shaft and remove outer snap rings from bearings.

b. Disassembly of Shift Levers & Interlock Assembly

NOTE: It is not necessary to remove shift lever and interlock assemblies unless the inter-

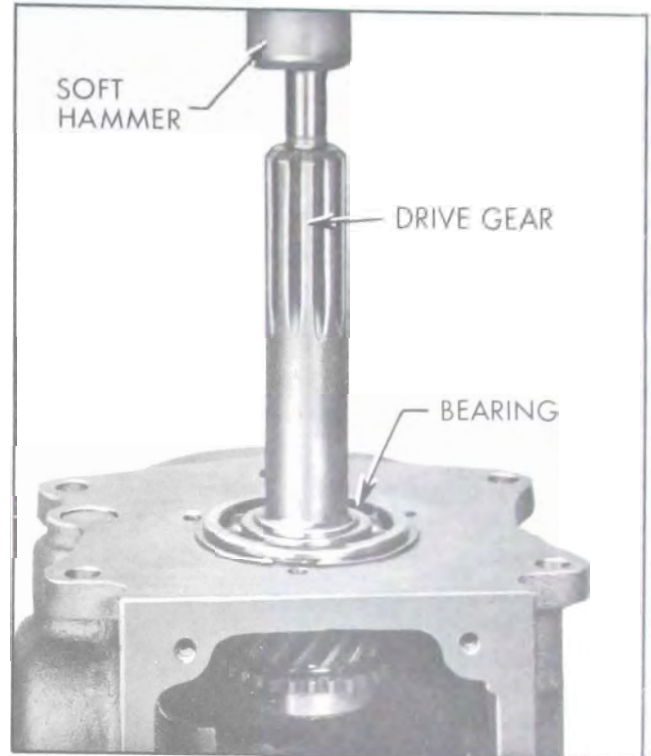

Figure 4-21—Removing Main Shaft or Drive Gear Bearing

lock does not function properly and repairs are to be made to these assemblies. Badly worn parts will cause too much interlock sleeve end clearance. See Figure 4-26.

1. Remove shift levers. Note positions of these levers.

2. Using a suitable punch, drive tapered shift shaft lock pins upward until shafts are free.

3. Remove shafts from inside case, being careful to catch the two interlock balls. Pry oil seals from shaft bores.

4. Remove interlock sleeve, spring and pin.

c. Disassembly of Synchronizer Assembly

1. Remove rear bronze blocking rings.

2. Remove spring from recess in both ends of hub.

3. Slide sleeve off hub. (The shift plates will fall from position).

d. Disassembly of Counter Shaft Assembly

1. Remove thrust washers, noting position.
2. Remove bearing loading tool to free four bearing spacers (washers), 44 needle rollers and ϕ tubular spacer.

4-14 CLEANING & INSPECTION OF TRANSMISSION PARTS

Clean and inspect all ball and roller bearings. Thoroughly clean all other parts except rubber mountings in CLEAN solvent and wipe dry with CLEAN cloths. Inspect parts as follows:

a. Gears and Shaft. Carefully inspect teeth and other ground surfaces of all gears for wear, scoring, pitting, chips, nicks and burrs. Do not confuse manufacturing cutter marks with scores or pits. Conical surfaces of gears where contacted by synchronizer blocking rings must be smooth and free of burrs. Slight scores or burrs may be honed off with a fine stone. However, if any gear is chipped or excessively worn it should be replaced. Inspect all shafts for wear roughness on bearing surfaces. Check fit of gears on shafts upon which they are mounted. The gear must slide freely on splined section of main shaft, but without appreciable backlash.

b. Synchronizer Blocking Rings. The conical surfaces of blocking rings must be free of burrs or scores, and oil grooves must be clean. Never polish this surface or change the angle.

c. Shifter Fork and Shoe, Shaft and Cam. Check all parts for wear. Check shifter fork and shoe to see whether they are bent. Procedure for checking clearance at interlock assembly is described in paragraph 4-15, c.

d. Seals and Gaskets. All seals and gaskets should be replaced during reassembly of transmission.

4-15 ASSEMBLY OF TRANSMISSION ASSEMBLY

During assembly, apply a thin coating of transmission lubricant on all parts. Always use new seals and gaskets when reassembling transmission.

a. Assembly of Counter Shaft Assembly

1. Install Bearing Loading Tool J-8965 in counter gear.

2. Insert tubular spacer.

3. Hold counter gear in vertical position and while supporting bearing loading tool from below, insert inner bearing spacer (washer) and place 22 needle rollers in position around loading tool using heavy grease to hold them in place. Insert outer bearing spacer. Repeat this procedure on opposite end. See Figure 4-22.

4. Install inner rear bronze thrust washer so that lugs engage notches in counter gear. Install outer rear steel thrust washer. Large front thrust washer should not be installed at this time.

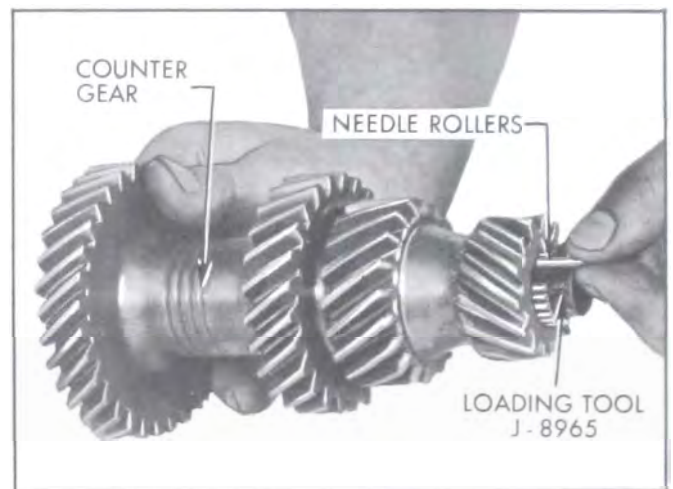

Figure 4-22—Loading Needle Rollers

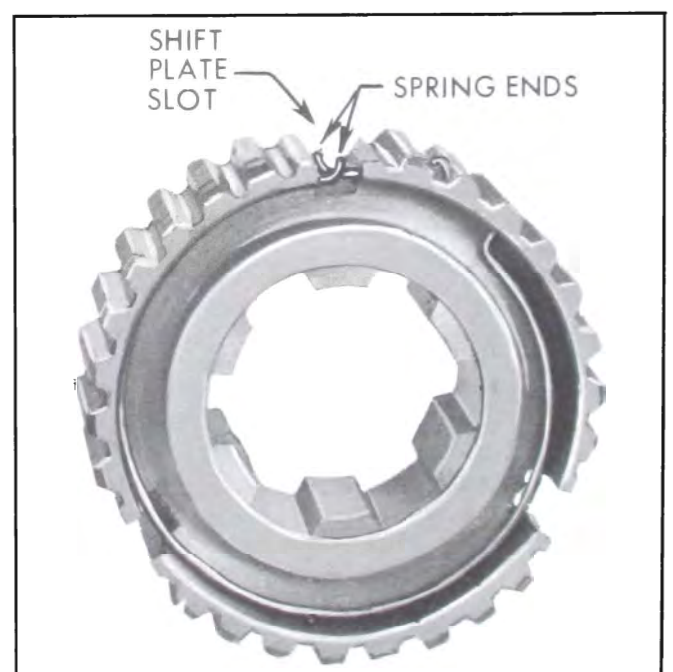

Figure 4-23—Installing Synchronizer Springs

b. Assembly of Synchronizer Assembly

1. Install springs solidly in recesses on both ends of synchronizer hub. One end of both springs should be located in same shift plate slot so that springs will extend in opposite directions from each other. Install shift plate directly over these ends. See Figure 4-23.

2. While holding shift plates in position (in grooves) on hub, slide synchronizer sleeve over hub until detent is felt. The extended tapered portion of the sleeve faces the same direction (front) as the long extended portion at the center of the hub. See Figure 4-24.

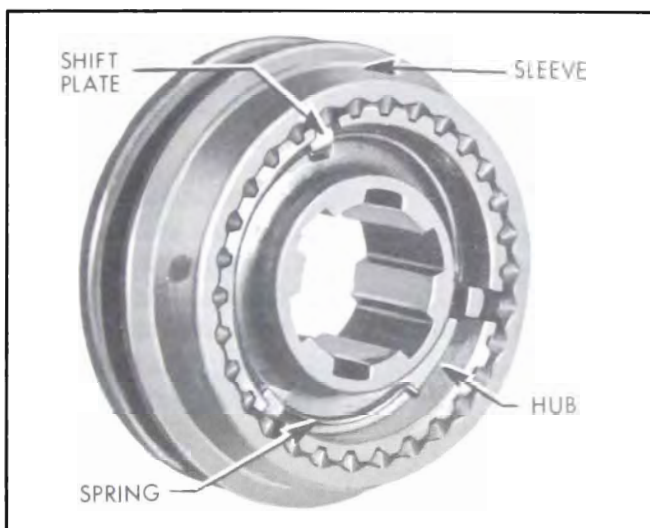

Figure 4-24—Synchronizer Assembly

3. Place rear blocking ring in position at rear end of hub and rotate until shifting plates match notches in blocking ring. Blocking ring remains free until assembly of transmission.

c. Installation of Shift Levers and Interlock Assembly

1. Insert new oil seals if removed. Apply transmission lubricant in seals and shaft holes.

2. Install second-third shifter shaft and cam. The second-third shifter shaft and cam is identified by the shorter cam ramps between detent notches on the cam.

3. Insert interlock sleeve, spring and pin in housing.

4. Install first-reverse shifter shaft and cam. Install levers, flat washers, lock washers and nuts on both shafts. The offset lever

and equalizer pivot nut are installed on the second-third shift shaft.

5. Move first-reverse cam toward transmission housing. Install interlock ball and move cam back to original (normal) position allowing the neutral (center) notch of cam to retain ball. Install tapered shift shaft lock pin. See Figure 4-25.

6. Using procedure in Step 5, install interlock ball at second-third cam.

7. Shift second-third shift lever into second speed position. With one end of interlock sleeve against first-reverse cam, the clearance between sleeve and second-third cam should be .001" - .007". See Figure 4-26. If clearance

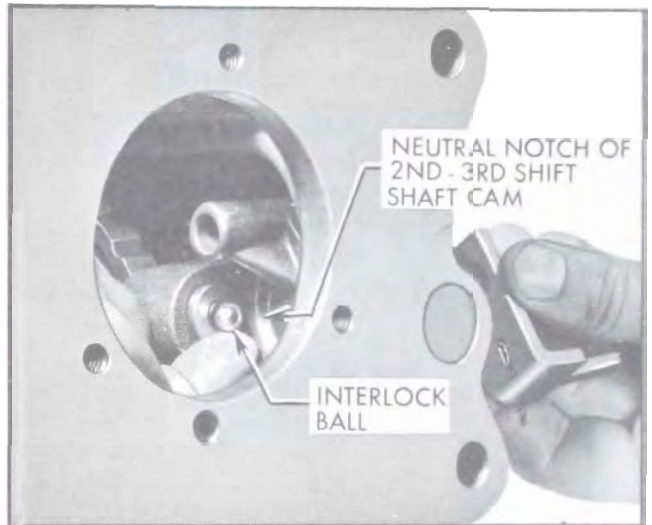

Figure 4-25—Installing Interlock Ball

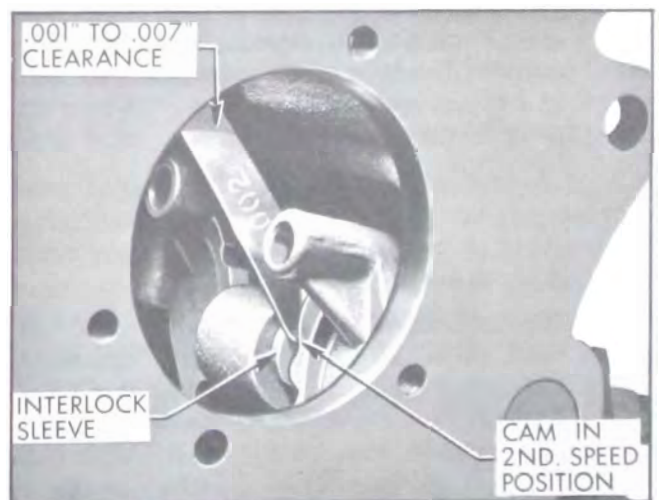

Figure 4-26—Checking Interlock Sleeve End Clearance

is greater than specified, and if it seems possible that transmission can be forced into two gears at once, old interlock sleeve should be measured with a micrometer and replaced with a new longer sleeve. Sleeves are available in five lengths: 1.287", 1.291", 1.295", 1.299" and 1.303".

d. Assembly of Drive Gear and Main Shaft Parts

1. If front bearing was removed, locate slinger washer on drive gear shaft with raised center portion toward front. Press new bearing

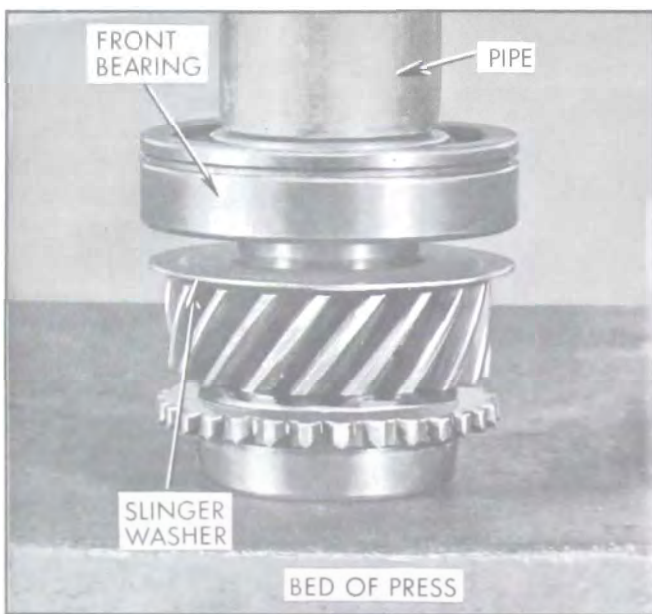

Figure 4-27—Installing Front Bearing

on shaft with outer snap ring groove toward front. See Figure 4-27. Install bearing outer snap ring and thickest shaft snap ring that will properly seat in snap ring groove. (Snap ring is available in three thicknesses.)

2. If rear bearing was removed, press new bearing on main shaft with outer snap ring groove toward rear. Install bearing outer snap ring and shaft snap ring.

3. With Bearing Loading Tool J-8965 in place, and with all counter gear assembly parts in place except front thrust washer, lower counter gear vertically through top of transmission case with rear (small section of counter gear) down. Then position counter gear in a horizontal position to allow front of counter gear to pass projections in transmission case. See Figure 4-28.

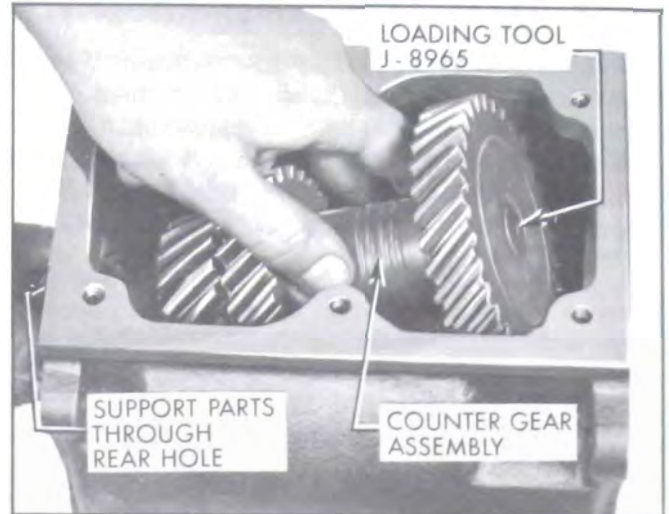

Figure 4-28—Installing Counter Gear

4. Locate counter gear in normal position with lug on outer rear thrust washer up, and move bearing loading tool rearward approximately 1/4", to pass into bore in case. Insert large front thrust washer with lug to front so as to engage slot in case. Align hole in washer with bore in counter gear and move bearing loading tool forward allowing counter gear to drop to bottom of case.

5. Check end clearance of counter gear using feeler gauge between two rear thrust washers. Limits are .005" - .017". Replace thrust washers if clearance is found to be excessive. See Figure 4-29.

6. Locate reverse idler gear in position with hub section and chamfered side of teeth forward. Drive reverse idler shaft in through rear of case with lock plate slot toward counter shaft bore. Leave shaft projecting approximately 1/16" from fully installed position.

7. Insert first-reverse shift shoe into first-reverse shift shaft and install main shaft and bearing through rear bearing bore in transmission case. As shaft is being installed: (1) slide first-reverse gear onto splines with groove on gear toward front, (2) slide second speed gear on shaft with extended portion toward front, (3) with rear blocking ring in position, slide synchronizer assembly onto splines with extended portion of synchronizer sleeve toward front. Install main shaft snap ring. See Figure 4-19. Insert second-third shift fork in second-third shift shaft and engage shift fork in groove on synchronizing

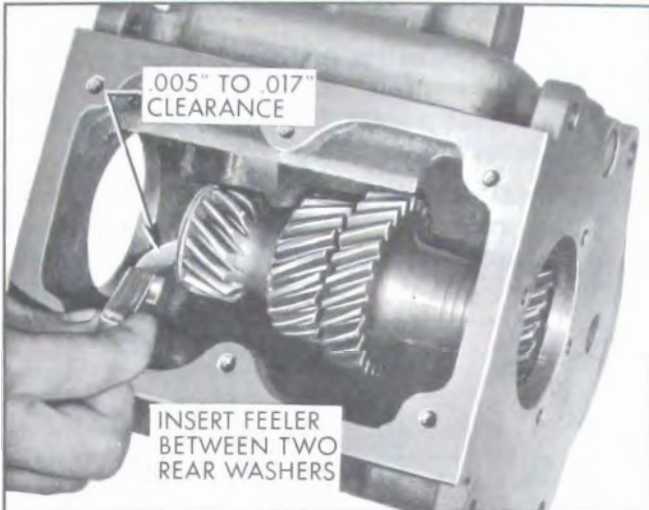

Figure 4-29—Checking End Clearance of Counter Gear

sleeve. With first-reverse shift shoe offset toward front, engage shift shoe in groove on first-reverse gear. Move complete main shaft assembly forward until rear bearing is fully installed in bore of case.

8. With synchronizer hub and second gear pressed forward against snap ring, there should be from .003'' to .016'' end clearance between second speed gear and front facing of first-reverse gear splines. This is a selective fit of main shaft, second speed gear, and synchronizer hub. Replace worn parts if clearance is found to be excessive. See Figure 4-30.

9. Place front blocking ring in position at

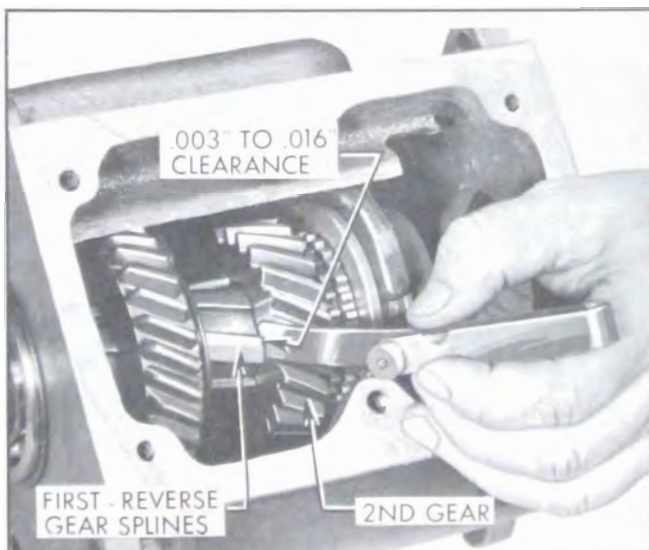

Figure 4-30—Checking End Clearance of Second Speed Gear

front end of synchronizer hub and rotate until shift plates match notches in blocking ring.

10. Insert 14 bearing rollers in drive gear. Hold in place using heavy grease. See Figure 4-31.

11. Install drive gear and bearing through front bearing bore in transmission case, sliding bearing rollers in rear end of drive gear over bearing surface on front of main shaft.

12. Check clearance between front blocking ring teeth and drive gear teeth by lightly seating blocking ring on contacting surface of gear. Minimum clearance between blocking ring teeth and gear teeth should be .045''. Replace blocking ring if clearance is found to be less than the specified amount. Use same procedure to check clearance between rear blocking ring

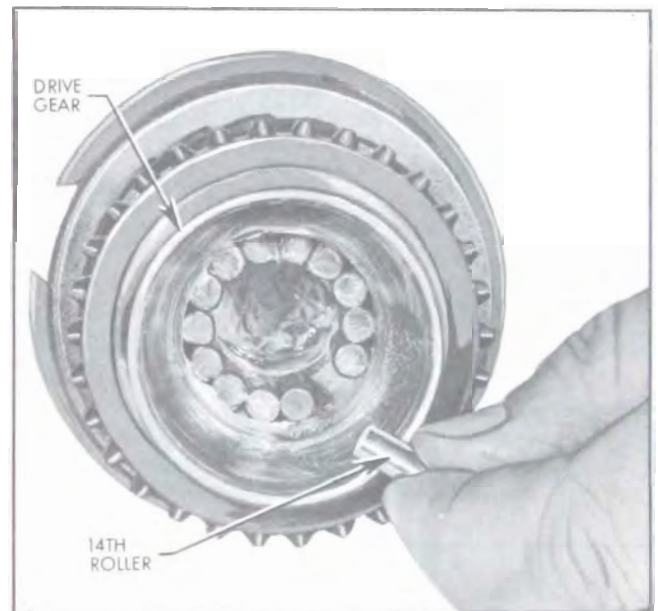

Figure 4-31—Loading Bearing Rollers in Drive Gear

teeth and second speed gear teeth. See Figure 4-32.

13. Turn transmission upside down on bench to allow counter gear and loading tool assembly to drop to normal position. Align bore in counter gear with bore in transmission case and install counter shaft through rear of case with lock plate slot facing reverse idler shaft. Leave counter shaft projecting approximately 1/16'' from fully installed position. See Figure 4-33.

14. Install lock plate. See Figure 4-14. Drive reverse idler shaft and counter shaft forward until lock plate is tight against case.

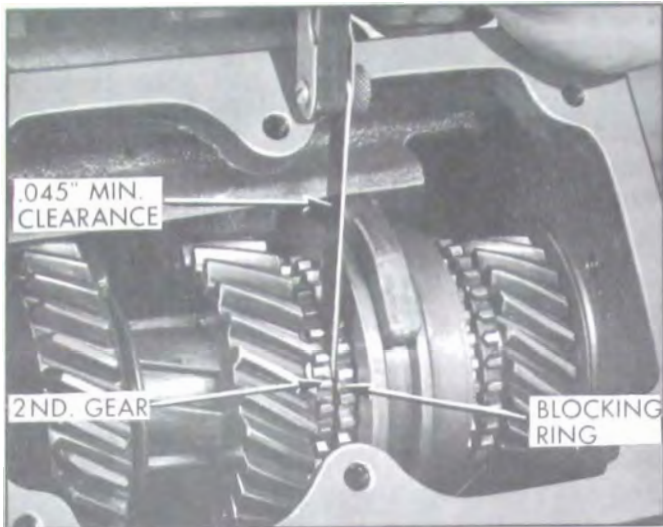

Figure 4-32—Checking Blocking Ring Clearance

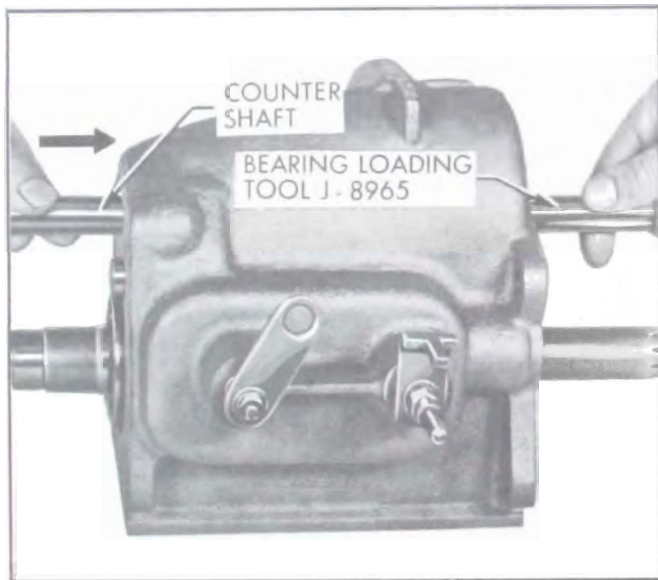

Figure 4-33—Installing Counter Shaft

15. Install front bearing retainer and gasket. Oil return hole in retainer and gasket must match oil return hole in case.

16. Install new oil seal in rear bearing retainer, using Seal Installer J-8864. See Figure 4-33A. Lightly coat seal with gear lubricant.

17. Slide speedometer worm gear over rear end of mainshaft and install rear bearing retainer and gasket.

18. Slide front companion flange part way on output shaft. Thread special screw through nut J-9376-2, then thread screw into output shaft till it bottoms. Drive flange onto shaft by turning nut J-9376-2. Remove tool and install regular bolt. Torque to 40 ft. lbs. See Figure 4-33B.

19. Install new O-ring seal on speedometer driven gear sleeve and install driven gear and

sleeve assembly. Install retainer and bolt.

20. Check operation of transmission by operating shift controls. Make certain main shaft and drive gear rotate free of each other when transmission is shifted into neutral.

21. Install top cover and gasket locating each with the stamped "FRONT" toward front of transmission. Install transmission drain plug.



Figure 4-33A—Installing Rear Bearing Retainer Oil Seal

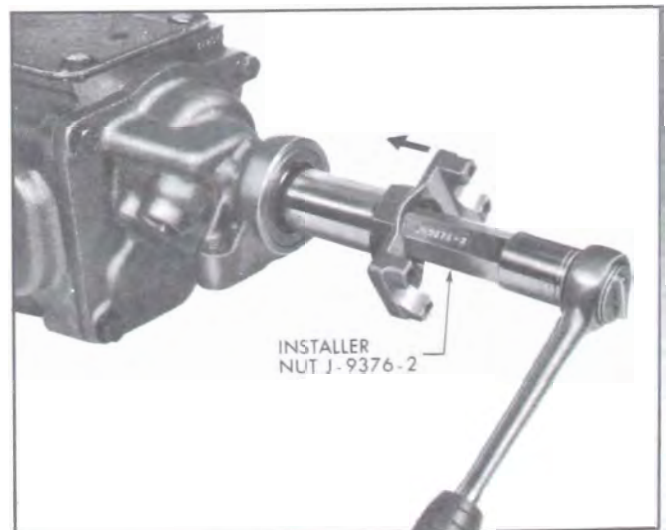
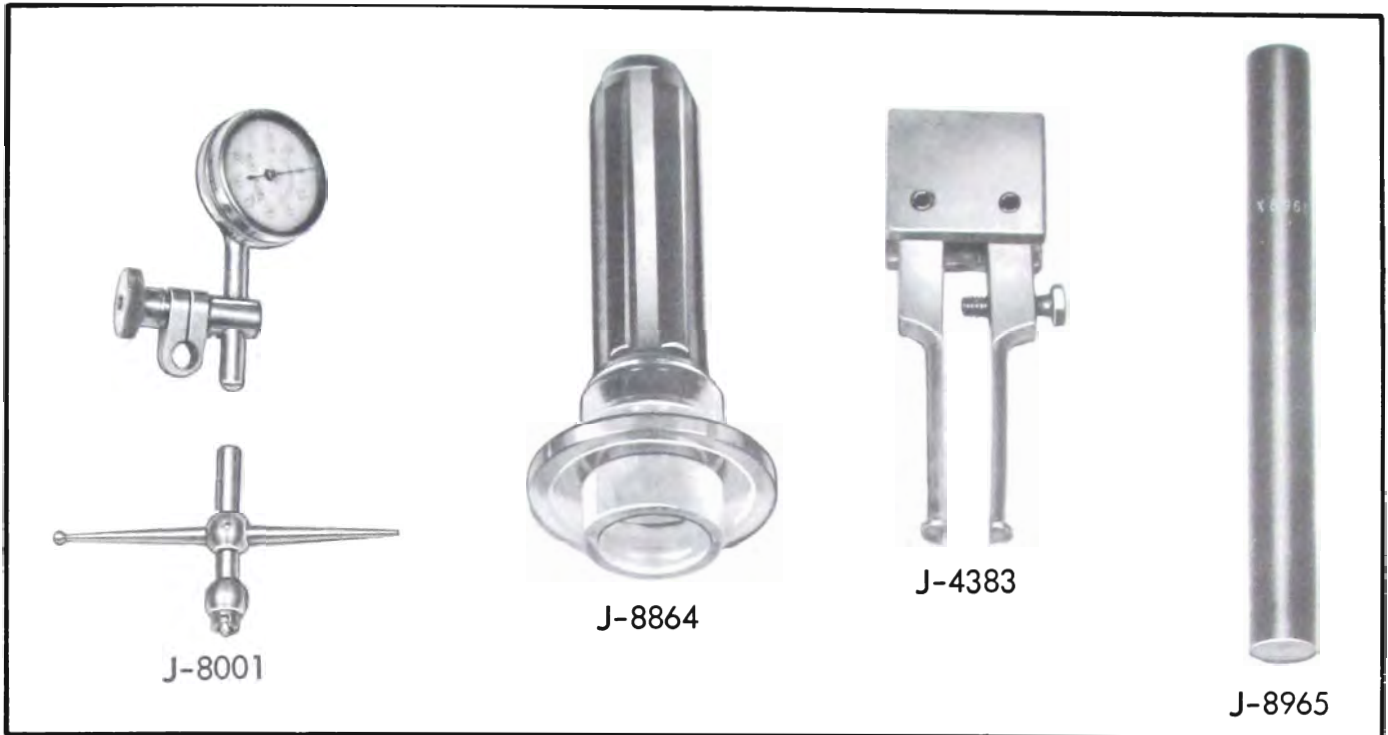

Figure 4-33B—Installing Front Companion Flange



CLUTCH - SYNCHROMESH TOOLS

- J-4383 Clutch Pilot Bearing Puller
- J-8001 Dial Indicator Set
- J-8864 Transmission Seal Installer
- J-8965 Counter Gear Bearing Loader

Figure 4-34—Clutch, S-M Transmission Special Tools