

SECTION 6-B REAR AXLE SERVICE PROCEDURES

CONTENTS OF SECTION 6-B

Paragraph	Subject	Page	Paragraph	Subject	Page
6-4	Removal and Installation of Rear Axle Assembly . . .	6-6	6-6	Assembly of Rear Axle Assembly	6-11
6-5	Disassembly of Rear Axle Assembly	6-6			

6-4 REMOVAL AND INSTALLATION OF REAR AXLE ASSEMBLY

It is not necessary to remove the rear axle assembly for any normal repairs. However, if the housing is damaged, the rear axle assembly may be removed and installed using the following procedure.

a. Removal of Rear Axle Assembly

1. Raise rear of car high enough to permit working underneath. Place a floor jack under center of axle housing so it just starts to raise rear axle assembly. Place car stands solidly under body members on both sides.

2. Mark rear universal joint and pinion flange for proper reassembly. Then disconnect rear universal joint from pinion flange by removing two U-bolts. Wire propeller shaft to exhaust pipe to support it out of the way.

3. Disconnect parking brake cables by removing adjusting nut at sheave. Remove cable connector and two clips and slide cables back until free of body.

4. Disconnect rear brake hose at floor pan. Cover brake hose and pipe openings to prevent entrance of dirt.

5. Disconnect shock absorbers at axle housing. Lower jack under axle housing until rear springs can be removed.

6. Disconnect upper control arms at axle housing.

7. Disconnect lower control arms at axle housing and roll rear axle assembly out from under car.

b. Installation of Rear Axle Assembly

1. Rest car solidly on stands placed under body side members, with rear end of car high

enough to permit working underneath. Roll rear axle assembly under car.

2. Connect lower control arms to axle housing.

3. Connect upper control arms to axle housing.

4. Place rear springs in position and jack axle housing upward until shock absorbers will reach.

5. Connect shock absorbers and tighten nuts to 40 ft. lbs. Tighten all control arm pivot bolts to 100 ft. lbs.

6. Connect parking brake cables. Adjust parking brake according to procedure in paragraph 9-9.

7. Connect rear universal joint to pinion flange according to alignment marks. Tighten nuts evenly to 15 ft. lbs. and bend lock plate tabs against nuts. If there is any doubt as to safety of lock plates, use new lock plates. CAUTION: U-bolt nuts must be torqued as specified, as overtightening will distort bearings and cause early failure.

8. Connect rear brake hose at floor pan. Bleed both rear brakes and refill master cylinder.

9. Fill rear axle with specified gear lubricant (see par. 1-4). If axle housing or any rear suspension parts were replaced due to damage, rear universal joint angle must be checked and adjusted if necessary. See paragraph 6-12.

6-5 DISASSEMBLY OF REAR AXLE ASSEMBLY

Most rear axle service repairs can be made with the rear axle assembly in the car by raising the rear end of the car with the rear axle hanging on the shock absorbers. See

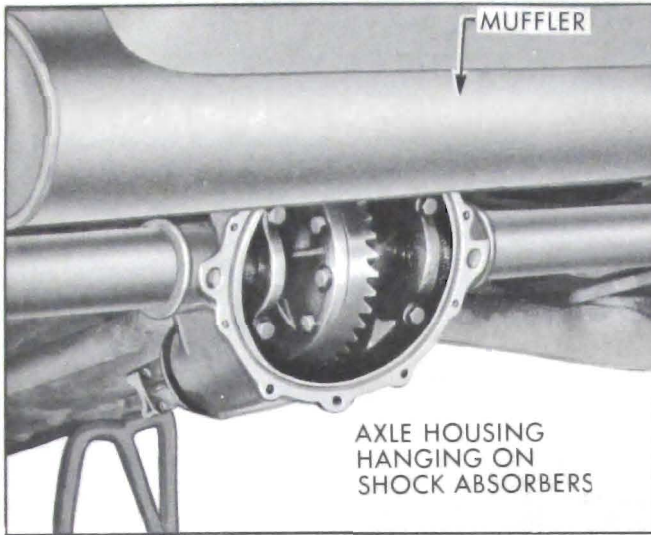

Figure 6-3—Rear Axle Assembly in Position for Repair

Figure 6-3. Rear axle lubricant may be drained by backing-out all cover bolts and breaking cover loose at the bottom.

a. Remove Axle Shaft Assemblies

1. Remove wheels. Notice that left side wheel bolts have left hand threads. Left side nuts are marked 'LH'.

2. Remove brake drums.

3. Remove nuts holding retainer plates to brake backing plates, pull retainers clear of bolts and reinstall two lower nuts finger tight to hold brake backing plate in position.

4. Pull out axle shaft assemblies using Puller J-8617 and Adapter J-2619-4 with a slide hammer. See Figure 6-4.

CAUTION: While pulling axle shaft out through oil seal, support shaft carefully in center of seal to avoid cutting seal lip.

b. Remove and Install Axle Shaft Bearing

1. Nick bearing retainer in 3 or 4 places with a chisel deep enough to spread ring. Retainer will then slip off. See Figure 6-5.

2. Press axle shaft bearing off using Puller Plate J-8621 with Remover J-6525. An arbor press may be used or a set-up may be made using Ram and Yoke Assembly J-6180 with

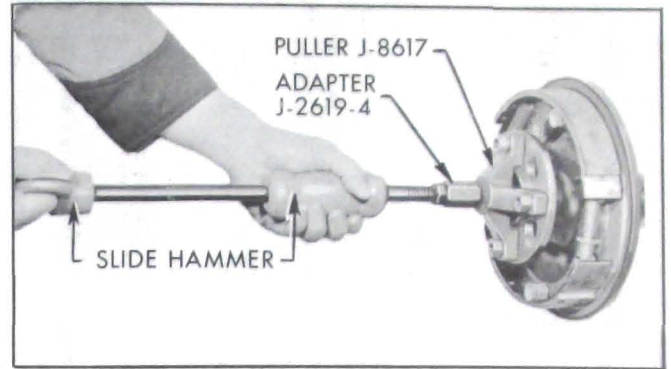

Figure 6-4—Removing Rear Axle Shaft

Adapter J-6258 and Puller J-8617. See Figure 6-6.

3. Press new axle shaft bearing against shoulder on axle shaft using Installer J-8853 with Holder J-6407. See Figure 6-7. **CAUTION:** Retainer plate which retains bearing in housing must be on axle shaft before bearing is installed; retainer gasket can be installed after bearing.

4. Press new retainer ring against bearing using Installer J-8853.

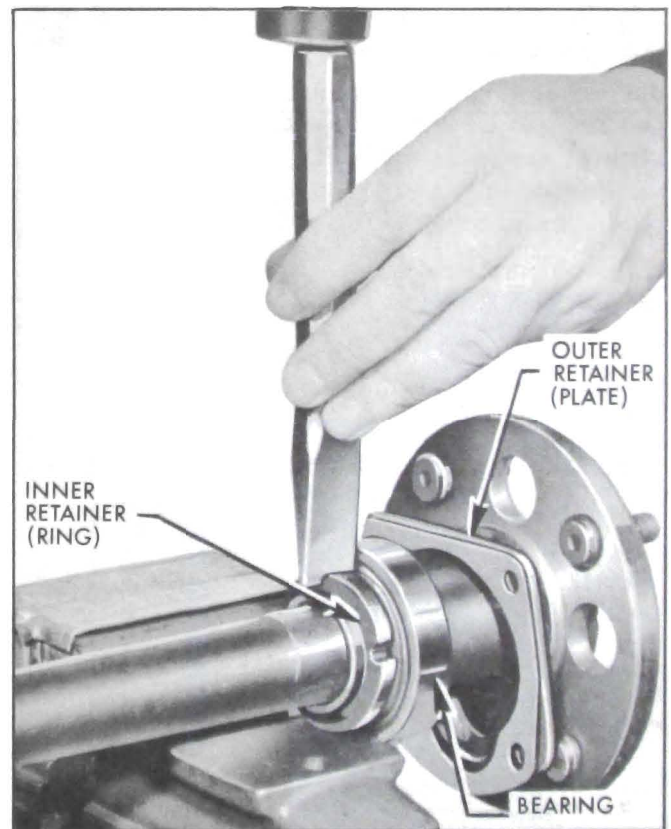

Figure 6-5—Removing Axle Shaft Bearing Retainer

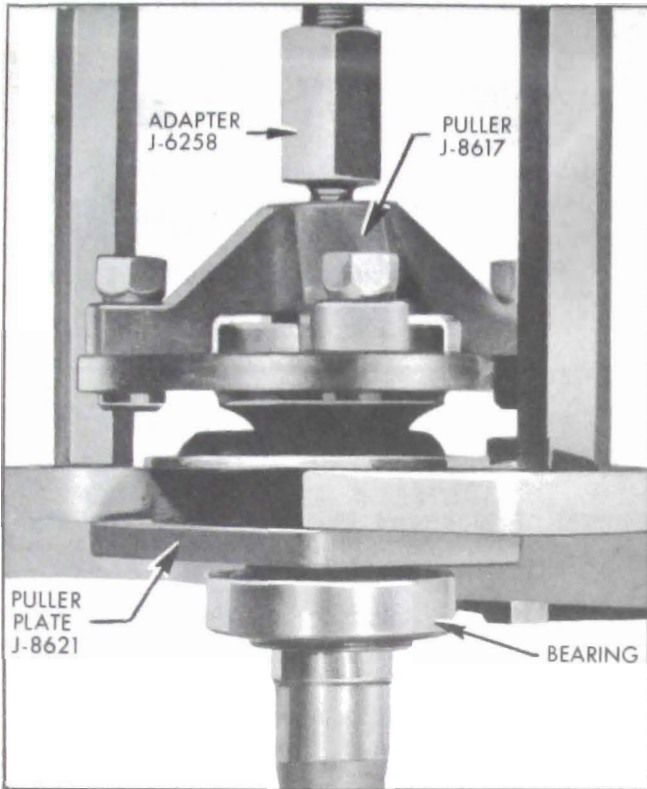

Figure 6-6—Removing Axle Shaft Bearing

c. Remove and Install Rear Wheel Bolt

1. To remove and install a rear wheel bolt, axle shaft assembly must be out of car. Re-

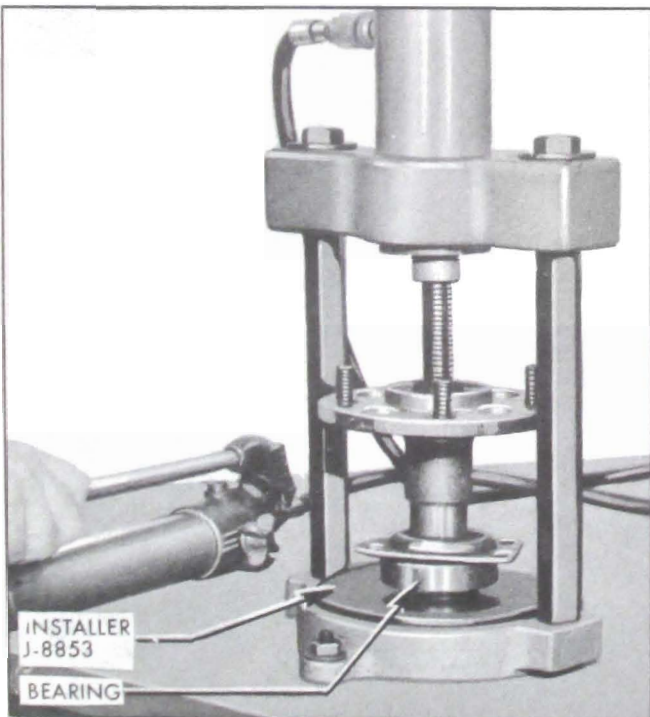

Figure 6-7—Installing Axle Shaft Bearing

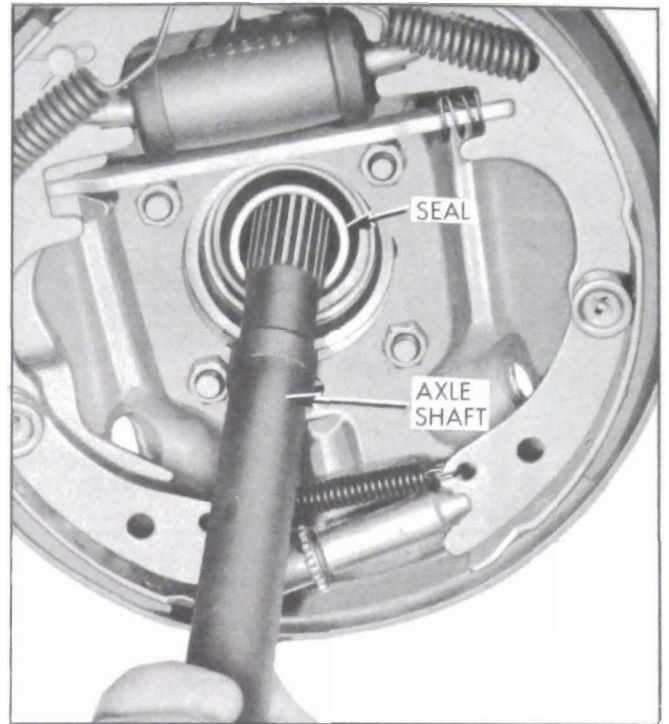

Figure 6-8—Removing Axle Shaft Seal

move rear wheel bolt by pressing from axle flange.

2. Install new rear wheel bolt by pressing through axle flange. Check new bolt for looseness; if bolt is loose, axle shaft must be replaced.

d. Remove and Install Axle Shaft Seal

1. Insert axle shaft so that splined end is just through seal.

2. Using axle shaft as a lever, push down on shaft until seal is pried from housing. See Figure 6-8.

3. Apply sealer to OD of new seal.

4. Position seal over Installer J-8610 and drive seal straight into axle housing until fully seated. See Figure 6-9.

e. Remove Differential Case Assembly

1. Before removing differential from housing, it is advisable to check the existing ring gear to pinion backlash as described in paragraph 6-6(h). This will indicate gear or bearing wear or an error in backlash or preload setting which will help in determining cause of axle noise. Backlash should be recorded so

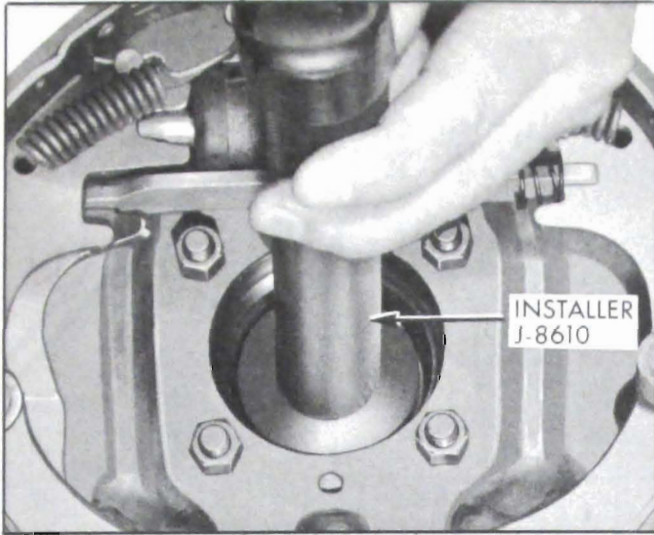

Figure 6-9—Installing Axle Shaft Seal

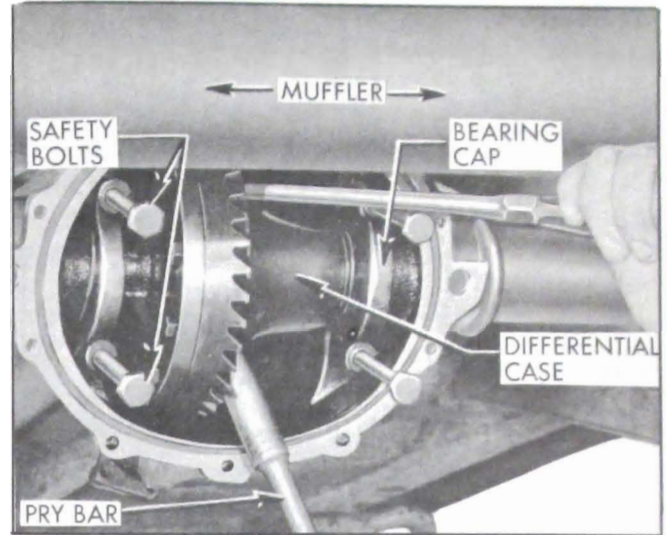

Figure 6-10—Removing Differential Assembly

that if same gears are reused, they may be reinstalled at original lash to avoid changing gear tooth contact.

2. Remove differential bearing cap bolts. Bearing caps are marked "R TOP" and "L TOP" in production to make sure they will be reassembled correctly.

3. As a safety precaution, install four 7/16-14 x 4 1/4 head bolts through bearing caps finger tight. NOTE: Bearing cap holes may be flanged inward slightly under bolt heads causing a bind on threads. If so, remove flange using a rat-tail file.

4. Using two pry bars, pry differential case assembly out carefully. See Figure 6-10. Differential will be held tightly if bearing preload is correct.

5. When differential is pried past a certain point, it will suddenly fall free. However, safety bolts installed in Step 3 will catch assembly. See Figure 6-11. Support differential with one hand and remove safety bolts. Place right and left bearing outer races and shims in sets with marked bearing caps so that they can be reinstalled in their original positions.

f. Disassemble Differential Case Assembly

1. If differential side bearings are to be replaced, insert Support J-8615 in center hole and pull bearing using Puller J-2241 A or Hydraulic Puller J-9005. See Figure 6-12.

2. Remove ring gear from case. If ring gear is tight on case, tap it off using a soft hammer; do not pry between ring gear and case.

3. Drive spring pin from differential pinion axle. See Figure 6-13. Drive pinion axle from case. Remove differential pinions, side gears and thrust washers from case.

g. Remove Pinion Assembly

1. Check pinion bearing preload as described in paragraph 6-6(d). If there is no preload reading, check for looseness of pinion assembly by shaking. Any noticeable looseness indicates worn or defective bearings requiring

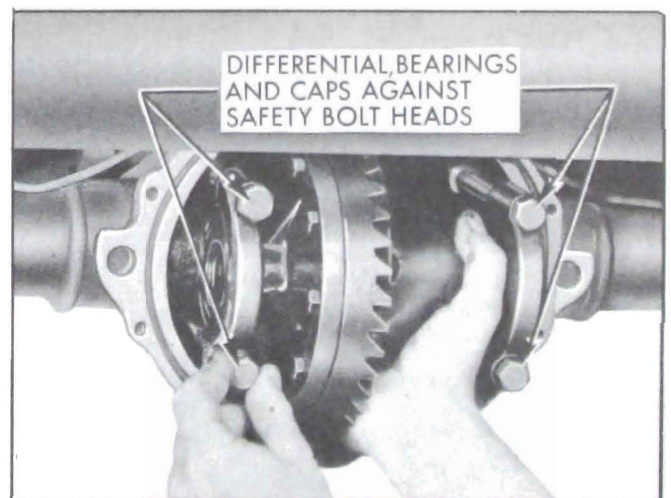

Figure 6-11—Differential Assembly Supported by Safety Bolts

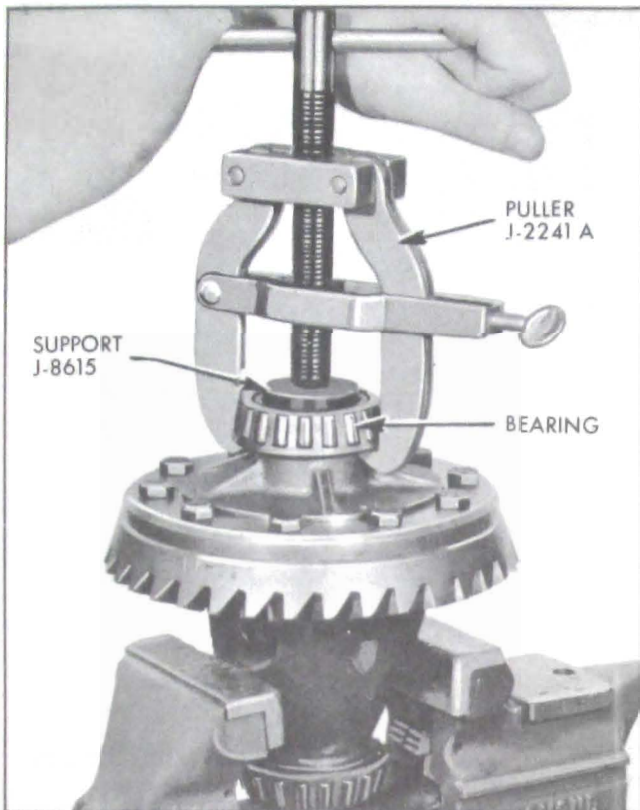

Figure 6-12—Removing Differential Side Bearing

replacement. If run long with very loose bearings, ring and pinion gears will be damaged and also need replacing.

2. It is also advisable to check pinion depth

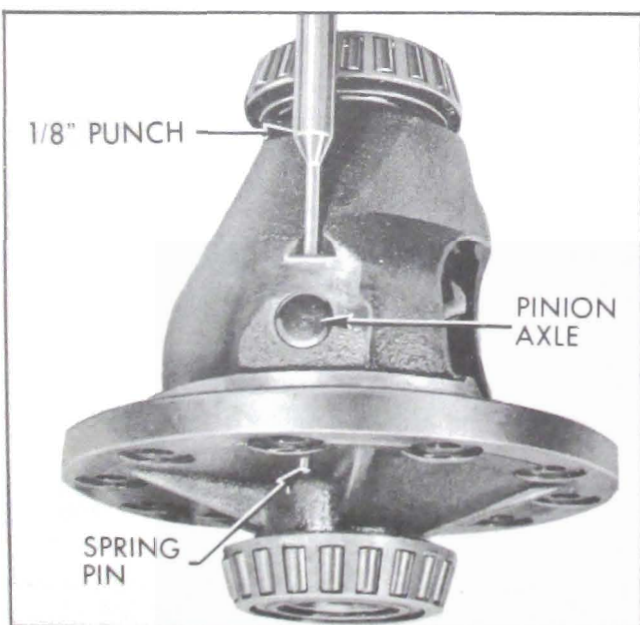

Figure 6-13—Removing Spring Pin from Pinion Axle

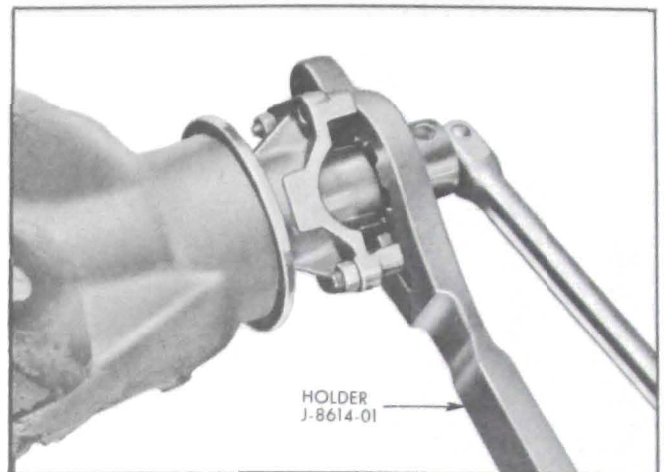

Figure 6-14—Removing Pinion Nut

setting as described in paragraph 6-6(f). This will indicate any error in the existing setting and will also enable used parts to be reinstalled at original setting to avoid changing gear tooth contact.

3. Install Holder J-8614-01 on pinion flange using two 5/16 - 18 x 2 bolts with flat washers. Remove pinion nut and washer. See Figure 6-14.

4. Pull pinion flange from pinion using Puller J-8614-02 in Holder J-8614-01. To install puller, back out puller screw, insert puller through holder and rotate 1/8 turn. See Figure 6-15.

5. Remove drive pinion assembly. If necessary, tap pinion out with a soft hammer being careful to guide pinion with hand to avoid damage to bearing outer races.

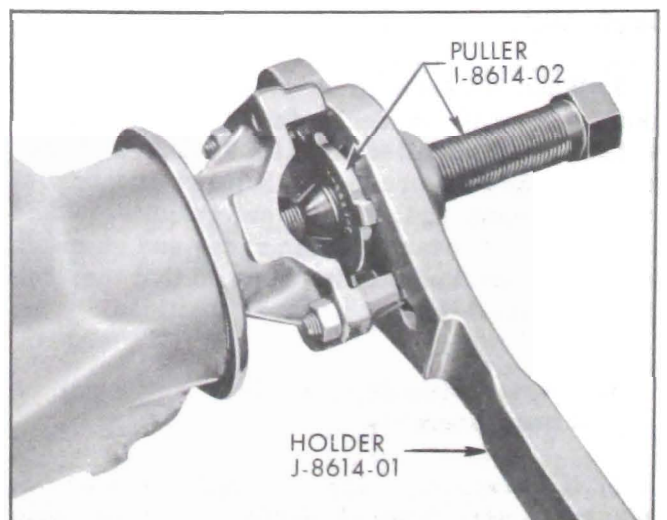

Figure 6-15—Removing Pinion Flange

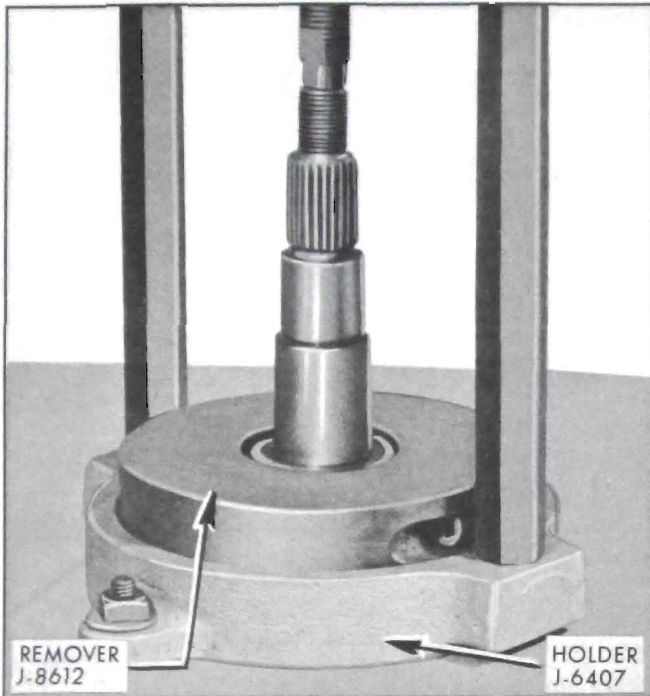

Figure 6-16—Removing Rear Pinion Bearing

h. Disassemble Pinion Assembly

1. If rear pinion bearing is to be replaced or pinion depth setting is to be changed, remove rear pinion bearing from pinion shaft using Remover J-8612 with Holder J-6407. See Figure 6-16.

2. Pry pinion oil seal from carrier and remove front pinion bearing. If this bearing is to be replaced, drive outer race from carrier using a drift.

3. If rear pinion bearing is to be replaced, drive outer race from carrier using a drift in slots provided for this purpose.

6-6 ASSEMBLY OF REAR AXLE ASSEMBLY

a. Assemble Differential Case Assembly

Before assembling the differential, examine the wearing surfaces of all parts for scoring or unusual wear. Also make certain that all parts are absolutely clean. Lubricate parts with rear axle lubricant just before assembly.

1. Place side gear thrust washers over side

gear hubs and install side gears in case. If same parts are reused, replace in original sides.

2. Position one pinion (without washer) between side gears and rotate gears until pinion is directly opposite from loading opening in case. Place other pinion between side gears so that pinion axle holes are in line, then rotate gears to make sure holes in pinions will line up with holes in case.

3. If holes line up, rotate pinions back toward loading opening just enough to permit sliding in pinion thrust washers.

4. Install pinion axle. Drive spring pin through hole in axle until flush with case.

5. Examine differential ring gear teeth for nicks or burrs or scoring. Any of these conditions will require replacement with a new gear set. Check numbers on new ring and pinion to make sure it is a matched set. See Figure 6-27.

6. After making sure that mating surfaces of case and ring gear are clean and free of burrs, thread two 3/8 - 24 x 2 studs into opposite sides of the ring gear, then install ring gear on case. See Figure 6-17. Install ring gear attaching bolts just snug. Torque bolts alternately in progressive stages to 60 ft. lbs.

7. If differential side bearings were removed, install new bearings using Installer J-8606 with Driver Handle J-8092. See Figure 6-18.

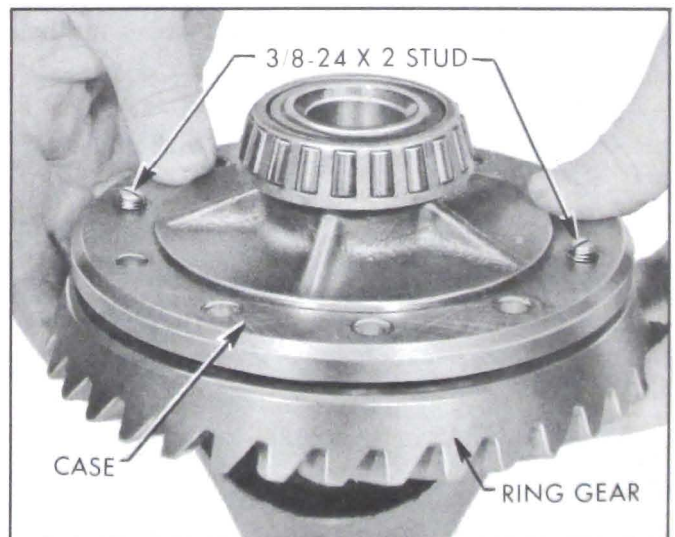

Figure 6-17—Installing Ring Gear on Differential Case

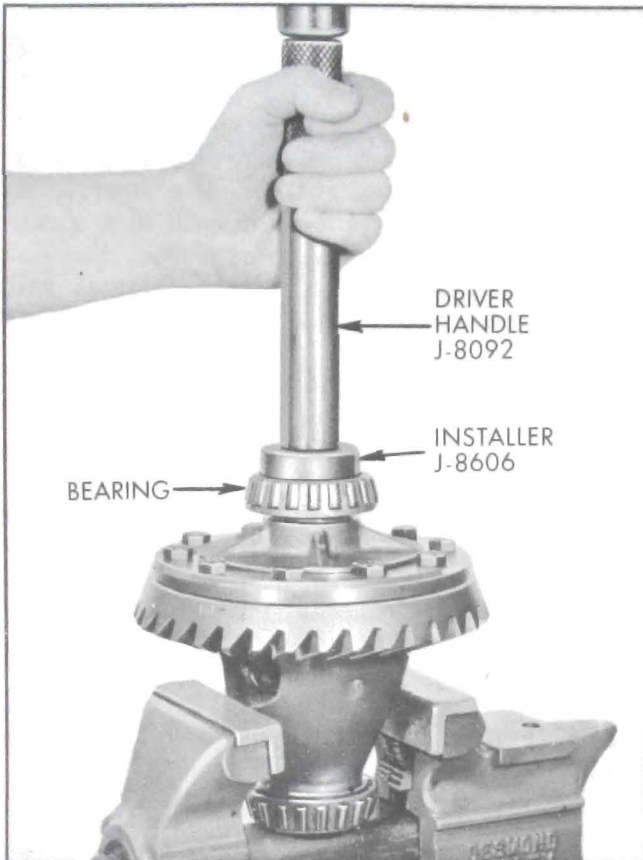

Figure 6-18—Installing Differential Side Bearing

b. Adjust Side Bearing Pre-Load

Differential side bearing preload is adjusted by changing the thickness of both the right and the left shim by an equal amount. By changing the thickness of both shims equally, the original backlash will be maintained. Differential adjusting shims are available in thicknesses ranging from .040" to .082" by two thousandths.

In order to adjust side bearing preload accurately, adjustment should be made before the ring gear and case assembly to be rotated freely.

1. Before installation of case assembly, make sure that side bearing surfaces in carrier are clean and free of burrs. Side bearings must be oiled with gear lube, and if same bearings are being reused, must have original outer races in place.

2. Place differential case and bearing assembly in position in carrier. If new side bearings were installed, use original adjusting shims; if same bearings are to be reused, select new right and left adjusting shims each .002" thicker than original shim. Slip right shim in position at right bearing, then drive

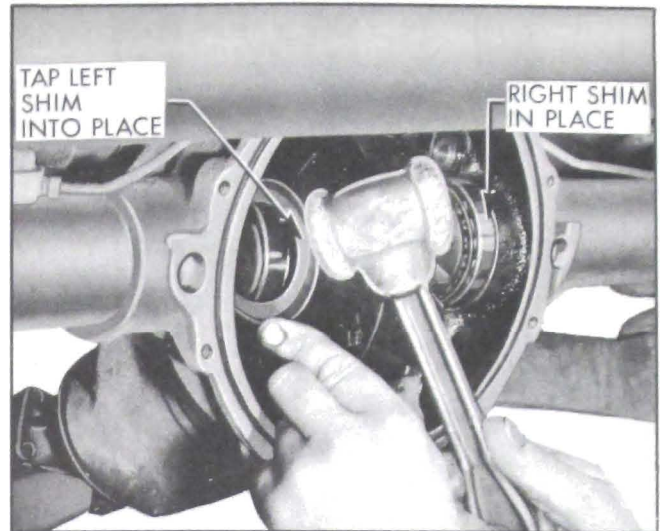

Figure 6-19—Installing Differential Adjusting Shim

left shim carefully into position using a soft hammer. See Figure 6-19.

3. As a safety precaution, install bearing caps using four 7/16-14x4 1/4 cylinder head bolts.

4. Rotate differential case several complete turns to seat bearings. Check bearing preload using an inch pound torque wrench connected at ring gear attaching bolt. With wrench projecting approximately straight out, bearing preload should read 20 to 30 in. lbs. with new bearings, or 10 to 20 in. lbs. with reused bearings. See Figure 6-20. If preload is not according to these specifications, increase shim thickness on each side .002" for each added 10 in. lbs. preload desired, or decrease shim thickness

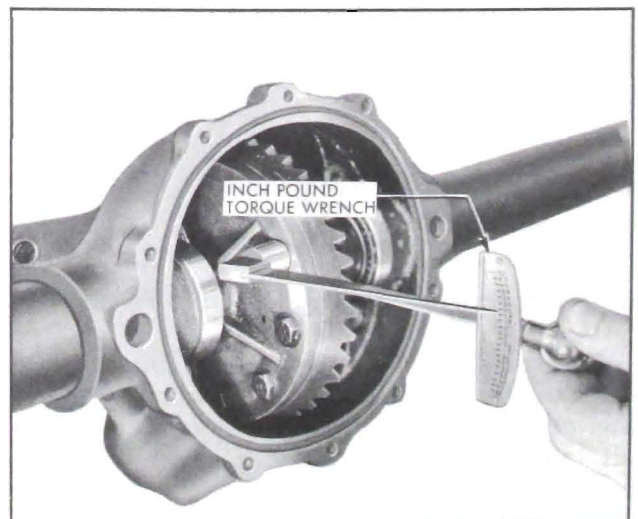

Figure 6-20—Checking Differential Bearing Preload

.002" on each side for each 10 in. lbs. preload to be subtracted.

5. When bearing preload is correctly adjusted, pry differential case assembly out, remove bearing caps and set aside. Be careful to keep bearing outer races and adjusting shims in sets with marked bearing caps so they can be re-installed correctly.

c. Assemble Pinion Assembly

1. If rear pinion bearing is to be replaced, install new outer race using Installer J-8608 with Driver Handle J-8092. See Figure 6-21.

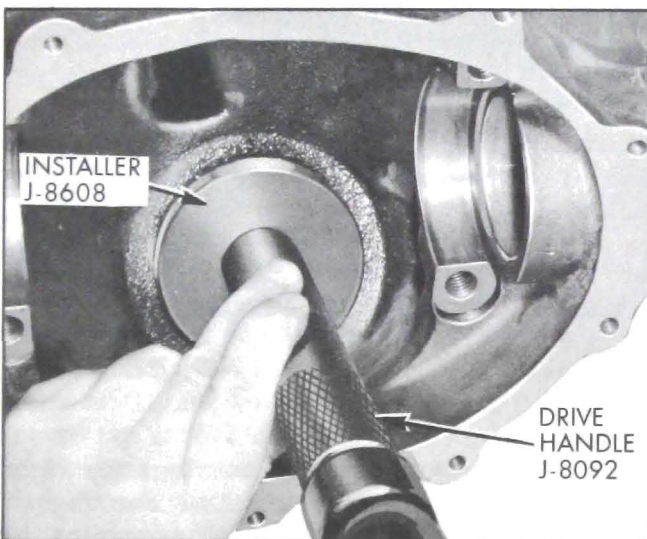

Figure 6-21—Installing Rear Pinion Bearing Outer Race

2. If front pinion bearing is to be replaced, install new outer race using Installer J-8611 with Driver Handle J-8092. See Figure 6-22.

3. Place original pinion shim on pinion and install rear pinion bearing using Installer J-8609 in an arbor press or as shown in Figure 6-23.

NOTE: Original shim is used only as a starting adjustment; pinion depth must be checked and readjusted if necessary, as described in subparagraph f below.

d. Install Pinion Assembly and Adjust Pinion Pre-Load

1. If new pinion bearings were installed, use original pinion preload spacers; if same bear-

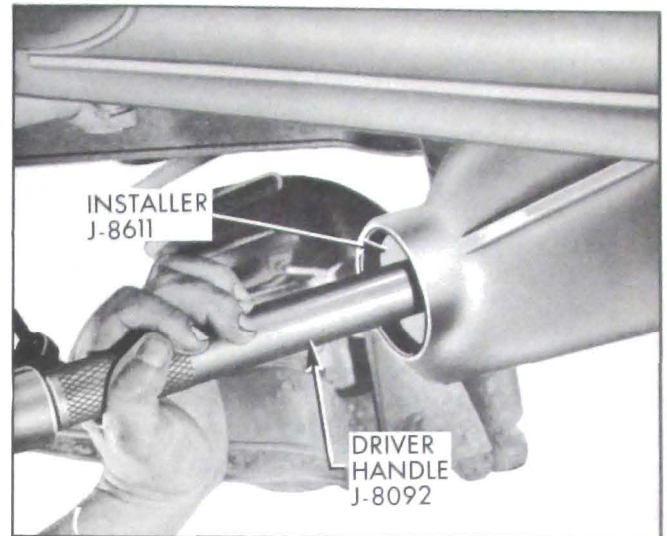

Figure 6-22—Installing Front Pinion Bearing Outer Race

ings are being reused, select a pair of pinion preload spacers having a total thickness of .002" less than original spacers. Install spacers on pinion and position pinion assembly in carrier. Pinion preload spacers are furnished to be used in pairs so that possible combined thickness ranges from .400" to .470" by thousandths.

2. Oil front pinion bearing and place in position on pinion. Hold pinion fully forward and drive front pinion bearing over pinion until seated using Installer J-8613. See Figure 6-24.

3. Install new O-ring seal on pinion. Coat

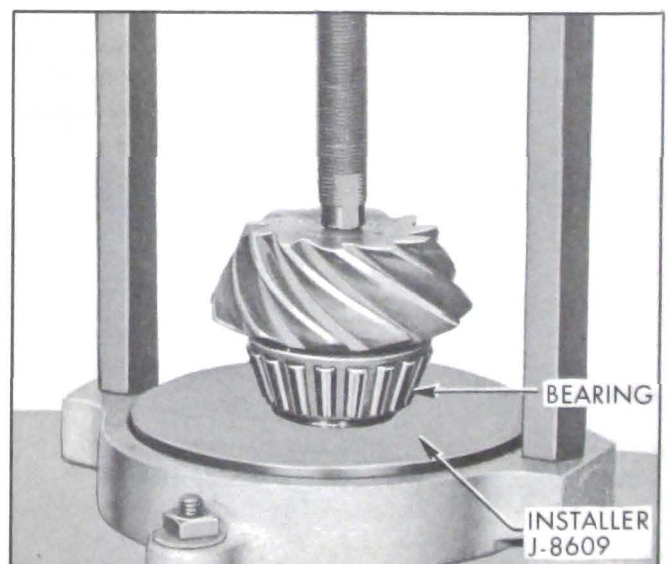

Figure 6-23—Installing Rear Pinion Bearing

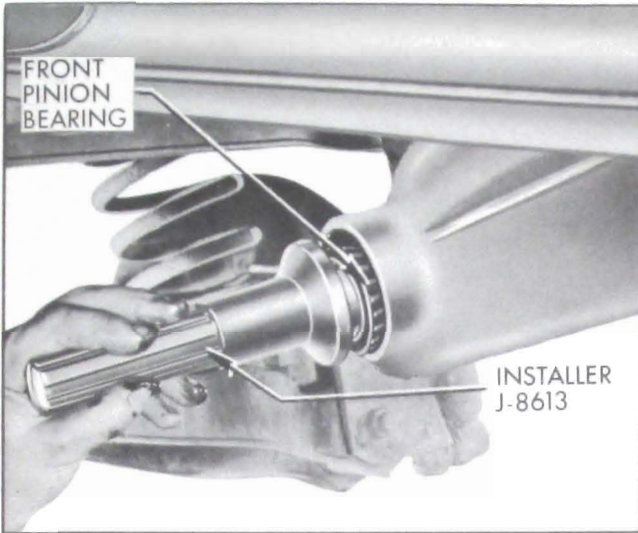

Figure 6-24—Installing Front Pinion Bearing

OD of new pinion oil seal with sealing compound and install seal using Installer J-8613. See Figure 6-25.

4. Coat lips of pinion oil seal and seal surface of pinion flange with gear lube. Install pinion flange on pinion by tapping with a soft hammer until a few pinion threads project through the flange.

5. Install pinion washer and nut. Hold pinion flange with Holder J-8614-01 and torque nut to 200 ft. lbs. Rotate pinion several times to seat bearings.

6. Check bearing preload using an inch pound torque wrench connected at pinion nut. Preload reading including drag of new seal should be

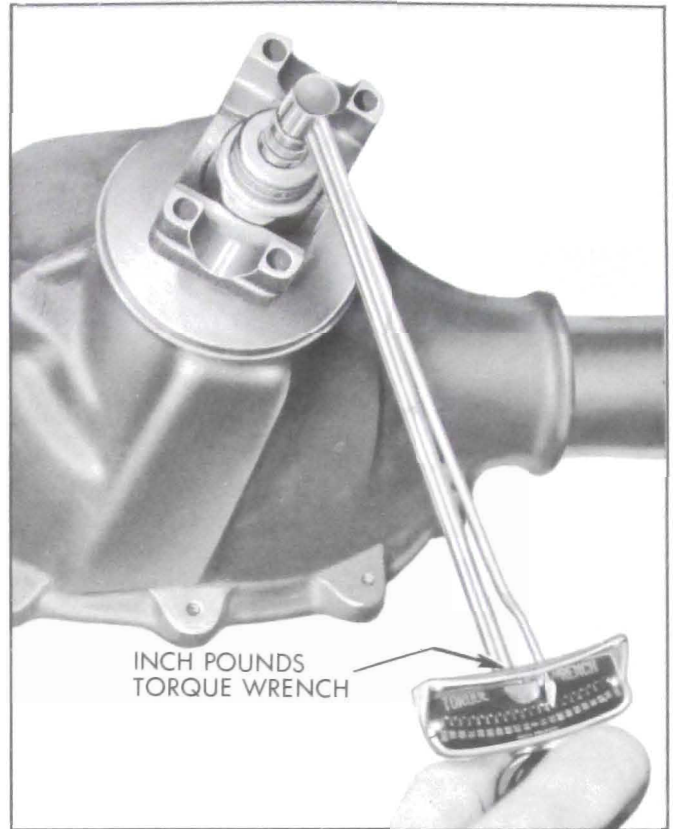

Figure 6-26—Checking Pinion Bearing Preload

25 to 35 in. lbs. with new bearings, or 15 to 25 in. lbs. with reused bearings. See Figure 6-26. If preload torque is not according to these specifications, reduce total pinion spacer thickness .001" for each added 10 in. lbs. preload desired, or increase total pinion spacer thickness .001" for each 10 in. lbs. preload to be subtracted.

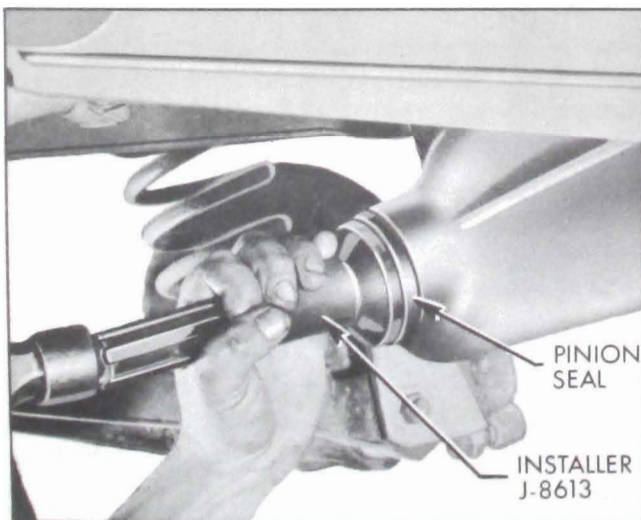

Figure 6-25—Installing Pinion Oil Seal

e. Pinion Setting Marks and Gauges

All ring and pinion gear sets are selectively matched for best operating position and proper tooth contact. After matching, a serial number is etched on one tooth of pinion and on rear face of gear to aid in keeping matched parts together. Parts having different seal numbers must never be used together.

Ring and pinion gear sets are matched in a special test machine which permits adjustment of pinion depth in ring gear until a point is reached where best operation and proper tooth contact under load are obtained. At this point, the setting of the pinion with reference to the centerline of the ring gear is indicated by the machine. This setting may vary slightly from

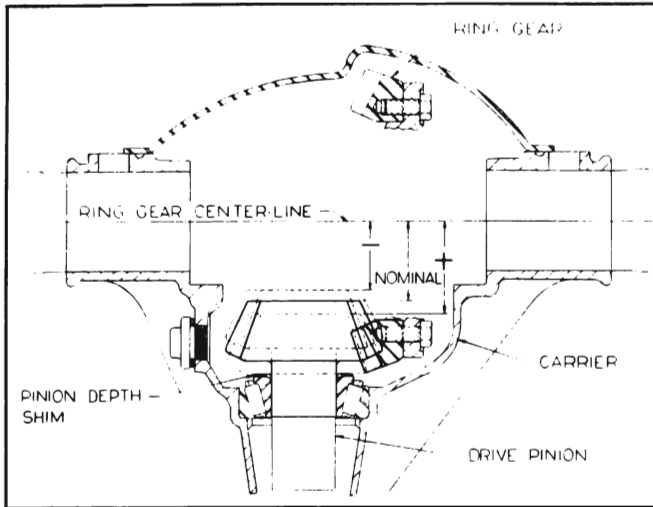

Figure 6-27—Nominal Pinion Depth Setting

the design or “nominal” setting due to allowable variation in machining the parts. See Figure 6-27.

This variation in thousandths of an inch over or under the “nominal” setting is etched on the small end of a pinion tooth. When a pinion is marked “+” (plus) it means that the rear face of the pinion when pressed in the carrier must be at the “nominal” distance from the centerline of the side bearing pedestals plus the amount indicated on the pinion tooth. When a pinion is marked “-” (minus) it means that it must be located at the “nominal” distance minus the amount indicated on the pinion tooth. See Figure 6-27.

The dial indicator type Pinion Setting Gauge J-8619 is used with adapters to provide a fast and accurate method of checking pinion location; it gives a direct reading on a dial indicator that does not require computation or reference tables.

Before checking the pinion setting, pinion bearing preload must be right because incorrect preload will cause a false pinion depth reading.

f. Check Pinion Depth

Pinion Setting Gauge J-8619 consists of a master gauge and an indicator gauge upon which a dial indicator is mounted. The master gauge is used for zeroing the indicator gauge. See Figure 6-28.

1. Make certain that the gauge parts are

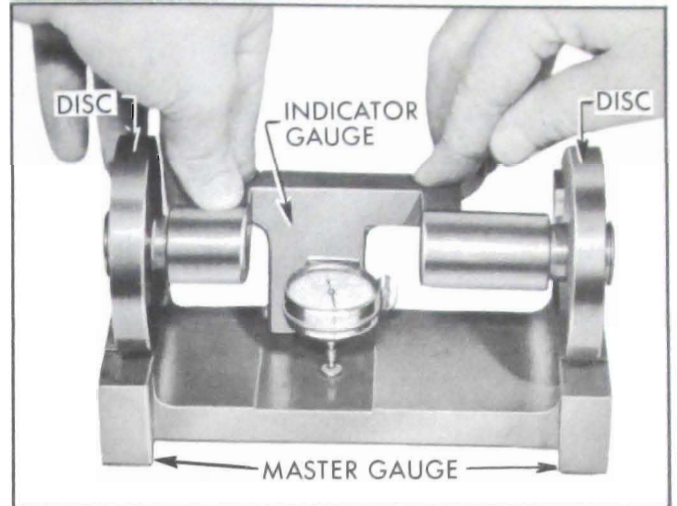

Figure 6-28—Zeroing Pinion Setting Gauge J-8619

clean, particularly the center and discs of the indicator gauge, and the centering hole and disc pads on the master gauge.

2. Install the discs from the large rear axle pinion setting gauge set on the indicator gauge and install the small contact button on the stem of the dial indicator. Mount the dial indicator on the indicator gauge. See Figure 6-28.

3. Place the indicator gauge on the master gauge so that the spring loaded center is engaged in the centering hole.

4. Center the indicator contact button on the indicator pad and lock the indicator by tightening the thumb screw.

5. Hold yoke down firmly, with both discs contacting the horizontal and vertical pads on master gauge, and set the dial indicator at zero. See Figure 6-28.

6. Make sure that differential bearing support bores are free of burrs and that the center of the pinion is clean.

7. Rotate the pinion until the blank tooth between the matching number and the pinion setting mark is slightly counterclockwise of top center (at about 11 o'clock). This tooth is called the gauging tooth (Figure 6-27) because it is used for locating and gauging during production and should therefore be used for gauging in service.

8. Place indicator gauge in carrier and turn pinion if necessary so that indicator contact

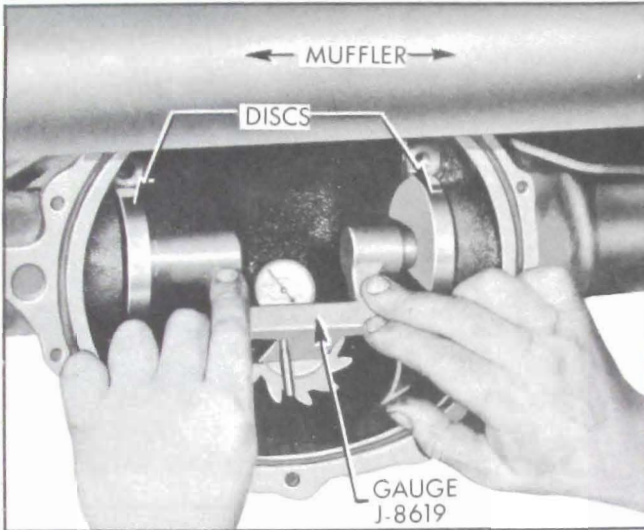

Figure 6-29—Checking Pinion Depth

button has a good contact with gauging tooth of pinion. See Figure 6-29.

9. Press gauge yoke firmly downward toward pinion and read dial indicator noting whether it is plus (+) or minus (-) as indicated by arrows on surface of yoke.

CAUTION: This reading does not indicate the thickness of the shim to be used, but only indicates the variation from the "nominal" setting of the gauging face of this pinion.

10. Recheck indicator "zero setting" on master gauge with discs to make sure it was not changed in handling.

11. If the old ring and pinion gear set is being reinstalled and it has been in use long enough to establish a wear pattern on teeth, the original pinion setting found before removal should be maintained to avoid changing tooth contact.

12. If the ring and pinion set is new, or has not been in use long enough to establish a wear pattern on teeth, the dial indicator reading should be within .0015" of the pinion setting marked on pinion.

13. If pinion setting is not as specified, adjust as follows:

g. Adjust Pinion Depth

The pinion setting is adjusted by changing the thickness of the shim which is located between the rear pinion bearing inner race and the head of the pinion. Pinion depth shims are available

in thicknesses ranging from .040" to .070" by thousandths.

1. Remove pinion assembly and press off rear pinion bearing using Remover J-8612 and Holder J-6407. See Figure 6-15.

2. Remove shim from pinion, wipe dry and measure its thickness with a micrometer. Service shims are marked with their thickness in thousandths. Measure shim anyway, however, as any slight error here will necessitate pulling pinion and bearing again.

3. Increase or decrease thickness of shim as required to obtain proper pinion setting.

If pinion is marked "+8", but gauge reads "+6", decrease thickness of shim by .002". If gauge reads "+10", increase thickness of shim by .002".

If pinion is marked "-8", but gauge reads "-6", increase the thickness of shim by .002". If gauge reads "-10", decrease thickness of shim by .002".

CAUTION: Whenever a new pinion is to be installed, its depth setting must be gauged. Even though the new pinion has the same depth marking, it may require a different thickness shim because the dimension from the gauging face to the bearing shoulder varies in different pinions.

4. Pinion preload was correct before starting pinion depth check. To maintain correct preload when it is necessary to change a depth shim, simply change preload spacers by same amount that shim thickness was changed. If thickness of shim was decreased .002", use spacers with a .002" less total thickness. If thickness of shim was increased .002", use spacers measuring .002" thicker.

5. Reinstall rear pinion bearing on pinion with new thickness shim. See Figure 6-22.

6. Reinstall pinion and bearing assembly carefully in carrier with new thickness preload spacers. Install pinion flange and nut and tighten to 200 ft. lbs. See Figure 6-25.

7. Recheck pinion setting with gauge. See Figure 6-29. Setting for new pinion must be within .0015" of setting marked on pinion. Setting for used pinion should be within .0015" of original setting (as checked before disassembly).

8. Recheck pinion bearing preload with inch pound torque wrench. Preload must not exceed

35 inch pounds including drag of lubricated new seal.

h. Install Differential Assembly and Adjust Backlash

Since differential side bearing preload was previously adjusted before installing the pinion assembly, it is only necessary now to adjust the ring gear to pinion gear backlash.

1. Install differential case and bearing assembly. Slip right shim into position at right bearing, then drive left shim into position using a soft hammer. See Figure 6-19.

2. Rotate differential case several times to seat bearings, then mount dial indicator as shown in Figure 6-30. Use a small button on indicator stem so that contact can be made near heel end of tooth. Set dial indicator so that stem is as nearly as possible in line with gear rotation and perpendicular to tooth angle for accurate backlash reading.

3. With pinion locked to carrier, check gear lash at 3 or 4 points around ring gear. Lash must not vary over .001" around ring gear.

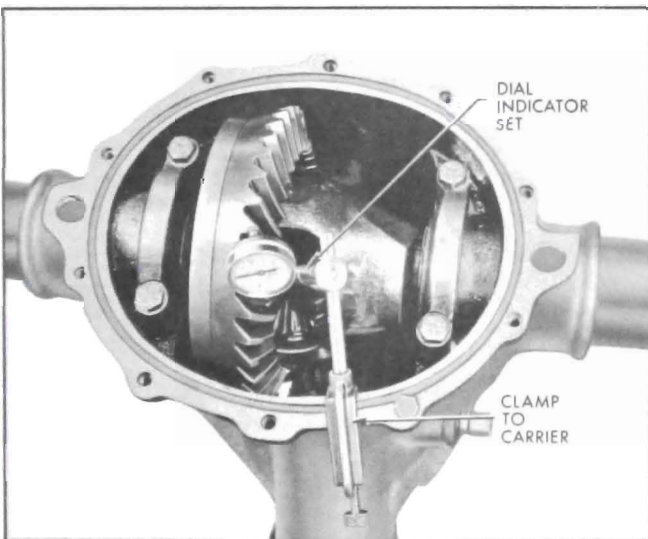

Figure 6-30—Checking Ring Gear to Pinion Backlash

If variation is over .001" check for burrs, uneven bolting conditions or distorted case flange, and make corrections as necessary.

4. Gear lash at the point of minimum lash should be .007" to .009" for all new gears. If adjustment is necessary, adjust to .008". If original gear set having a wear pattern is being reinstalled, original gear lash should be maintained within $\pm .001$ ".

5. If gear backlash is not within specifications, correct by increasing thickness of one shim and decreasing thickness of other shim the same amount. In this way, correct differential bearing preload will be maintained.

Shift .002" in shim thickness for each .001" change in backlash desired. If backlash is .001" too much, decrease thickness of right shim .002" and increase thickness of left shim .002". If backlash is .002" too little, increase thickness of right shim .004" and decrease thickness of left shim .004".

6. When gear backlash is correctly adjusted, install bearing caps according to markings and torque bearing cap bolts to 75 ft. lbs.

7. Install new cover seal in housing using heavy grease to retain it in groove. Install cover. Torque cover bolts to 25 ft. lbs.

i. Install Axle Shaft Assemblies

Notice that left axle shaft is shorter than right shaft; also that wheel bolts in left shaft have left hand threads.

1. Apply a coat of wheel bearing grease in bearing recesses of housing. Install new outer retainer gaskets. Insert axle shaft assemblies carefully until shaft splines engage in differential to avoid damage to seals.

2. Drive axle shaft assemblies into position.

3. Place gasket and retainer over studs and install nuts. Torque nuts to 60 ft. lbs.

4. Install brake drums over wheel bolts.

5. Install wheels and tighten wheel nuts.