

SECTION 8-B

POWER STEERING GEAR AND PUMP

CONTENTS OF SECTION 8-B

Paragraph	Subject	Page	Paragraph	Subject	Page
8-8	Power Steering Gear and Pump Specifications.....	8-10	8-14	Disassembly, Inspection, Assembly of Control Valve Assembly.....	8-21
8-9	Description of Power Steering Gear and Pump.....	8-11	8-15	Disassembly, Inspection, Assembly of Pitman Assembly.....	8-23
8-10	Operation of Hydraulic Power Mechanism.....	8-14	8-16	Disassembly, Inspection, Assembly of Rack-Piston and Worm Assembly.....	8-24
8-11	Trouble Diagnosis—Power Steering Gear and Pump....	8-18	8-17	Disassembly, Inspection, Assembly of Saginaw Oil Pump	8-29
8-12	Removal and Installation of Pitman Shaft Seal, Steering Gear and Pump.....	8-19			
8-13	Adjustment of Pitman Shaft and Steering Linkage.....	8-20			

8-8 POWER STEERING GEAR AND PUMP SPECIFICATIONS

a. Tightening Specifications

Use a reliable torque wrench to tighten the parts listed to insure proper tightness without

straining or distorting parts. These specifications are for *clean and lightly lubricated threads only*: dry or dirty threads produce increased friction which prevents accurate measurement of tightness.

a. Tightening Specifications

Part	Location	Thread Size	Torque-Ft. Lbs.
Bolt	Steering Shaft Coupling.....	5/16-24	20-25
Bolt	Gear Housing Side Cover.....	3/8-16	25-30
Bolt	Gear Housing End Cover.....	3/8-16	25-30
Nut	Pitman Shaft Lash Adjuster Lock.....	7/16-20	25-30
Bolt	Valve Body to Housing.....	5/16-18	15-20
Bolt	Gear Housing to Frame.....	7/16-14	30-40
Nut	Steering Wheel to Steering Shaft.....	1 1/16-20	40-45
Nut	Pitman Arm.....	7/8-14	90-110
Fitting	Return Hose.....	5/8-18	20-30
Fitting	Pressure Hose.....	7/16-24	10-15

b. Steering Gear Specifications

Gear Type.....	Recirculating Ball Nut and Worm
Make.....	Saginaw
Ratio, Actual.....	17.5 to 1
Steering Wheel Diameter.....	17.5"
Turns of Wheel, Left to Right (gear connected).....	3 1/4
Steering System Oil.....	Hydraulic Steering Oil or Dyna-flow Transmission Oil
Steering System Oil Capacity (Dry).....	1 3/4 qts.
Number and Type of Worm Shaft Bearings	
Radial Load.....	One Aluminum Bearing
End Thrust.....	Pre-Loaded Double Row Ball
Worm and Nut Balls—No. and Diameter.....	23, 13 Sizes—From .28077 to .28173 by .00008ths
Type of Pitman Shaft Bearings.....	Lubrited Malleable Iron
Pitman Shaft O.D.	
Upper.....	1.2455" to 1.2465"
Lower.....	1.2455" to 1.2465"
Pitman Shaft Bushing I.D.....	1.2495" to 1.2505"
Clearance.....	.003" to .005"
Housing I.D.....	3.123" to 3.126"
Piston O.D.....	3.120" to 3.122"
Clearance.....	.001" to .006"
Adjusting Screw and Shim Clearance in Pitman Shaft.....	.0" to .002"

c. Pump Specifications

Pump Capacity, gal./min. @ 400 RPM (Engine) x 700 psi.....	1.5
Relief Valve Opening Pressure, psi.....	950 to 1050
Pump Test Pressure, min. psi @ 400 RPM (Engine) and 170° F. oil temperature.....	850
Drive Belt Adjustment, Torque on Pulley Nut to Slip Belt.....	40-45 Ft. Lbs. (New Belt) 30-35 Ft. Lbs. (Old Belt)

8-9 DESCRIPTION OF POWER STEERING GEAR AND PUMP

Buick Power Steering, standard equipment on Series 50-70 and available as optional equipment on all other models, consists of an in-line power steering gear with the worm and ball nut, power piston and rack, and the power cylinder all on a single center line. The valve is mounted directly on the gear housing, thereby eliminating all external lines and hoses except the pressure and return lines between the valve and a high pressure pump.

The engine drives the oil pump which furnishes hydraulic pressure. When the engine is not running, or when any part of the power mechanism is inoperative, steering is entirely manual and requires only slightly more effort at the steering wheel than the manual gear used as standard equipment.

With the engine running, steering is entirely manual under conditions which require an effort of less than two and three-quarters ($2\frac{3}{4}$) pounds at the steering wheel rim. When a greater effort is required, the power mechanism operates to ASSIST in turning the front wheels. The effort then required at steering wheel rim is limited to a maximum of approximately six pounds for normal steering and parking conditions, compared to possibly fifty pounds with the standard manual gear. If some abnormal condition requires more work than the power mechanism can do, the driver must assist with increased effort at the steering wheel.

The driver's effort on the steering wheel is always proportional to the force necessary to turn the front wheels. When the effort on the wheel drops to less than two and three-quarters ($2\frac{3}{4}$) pounds as the turn is completed, power assistance ceases. When the wheel is released to recover from a turn, the front wheels may return to the straight-ahead position in the usual manner without assistance or interference from the power mechanism. Through this conventional steering action the driver always has the "feel" of steering.

It should be noted that power steering always follows the manual steering action. No

steering action is obtained except through the manual guidance of the driver.

The hydraulic units and steering gear housing are filled with the same oil as specified for Dynaflo transmissions.

a. Power Steering Gear Assembly

The power steering gear assembly is the recirculating ball nut and worm type, having a ratio of 17.5 to 1.

The upper end of the pitman shaft has a gear section meshing with a rack which is a part of the power piston. This rack-piston slides in the gear housing which is cylindrical. The rack-piston assembly consists of power piston and rack with a Teflon piston ring and also a ball nut locked rigidly in place with a retaining screw. See figure 8-11.

A worm shaft turns in the ball nut using selectively fitted steel balls as a rolling thread. The ball groove is shallower in the center of the worm so that when the proper size balls are used, there is a slight worm to ball nut pre-load in the straight ahead position.

Worm shaft radial loads are transmitted to the gear housing through an aluminum bearing surface at the upper end and through the rack-piston at the lower end. Worm shaft end thrust is caused by the tendency of the worm to thread itself into or out of the ball nut as the wheel is turned right or left. This end thrust is absorbed entirely by a pre-load thrust bearing. Any end thrust causes a movement of the thrust bearing center race which is held in position by centering springs; the more the end thrust, the more the movement of the center race up to a point where it bottoms in its housing. This movement of the center race is transmitted to the control valve through the valve actuating lever.

The upper steering shaft is a separate shaft supported in the steering column jacket. Its upper end is supported by a ball bearing; its lower end by an adapter and ball bearing assembly.

The upper steering shaft is connected to the power steering gear worm shaft through a flexible coupling. This flexible coupling helps absorb minor shocks and vibrations, dampens

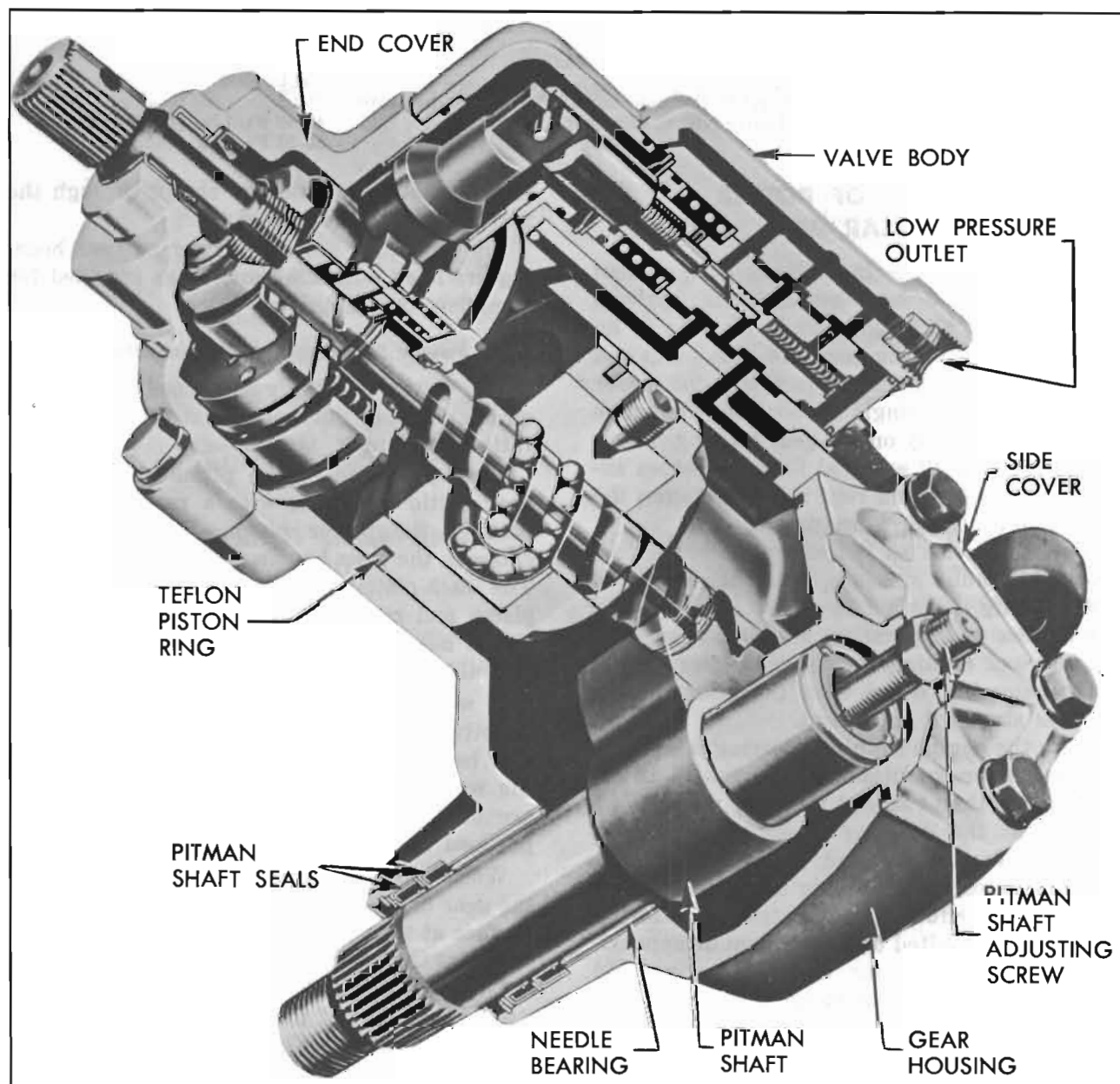

Figure 8-11—Power Steering Gear Assembly

out hydraulic noises and gear rattle, and also allows slight variations in alignment between the power gear assembly and the steering column jacket assembly.

b. Hydraulic Valve

The hydraulic valve controls the flow of oil from the pump to the proper side of the power rack-piston when power assistance is required and cuts off this flow when power assistance is not required. It also regulates the effort at steering wheel within the normal range of two and three-quarters ($2\frac{3}{4}$) to six (6) pounds so that this effort is proportional to the force

necessary to turn the front wheels, thereby providing the "feel" of steering previously mentioned. See Figure 8-11.

The valve spool is held in a neutral position by means of a valve centering spring located in the valve reaction chamber plus the thrust bearing centering springs. The hydraulic valve contains a second spool, located in the center of the valve spool. This second spool establishes the maximum pressure that may be produced in the reaction chamber and thereby decreases the hand wheel effort when parking.

During a left turn, the thrust bearing is moved up and in a right turn the thrust bear-

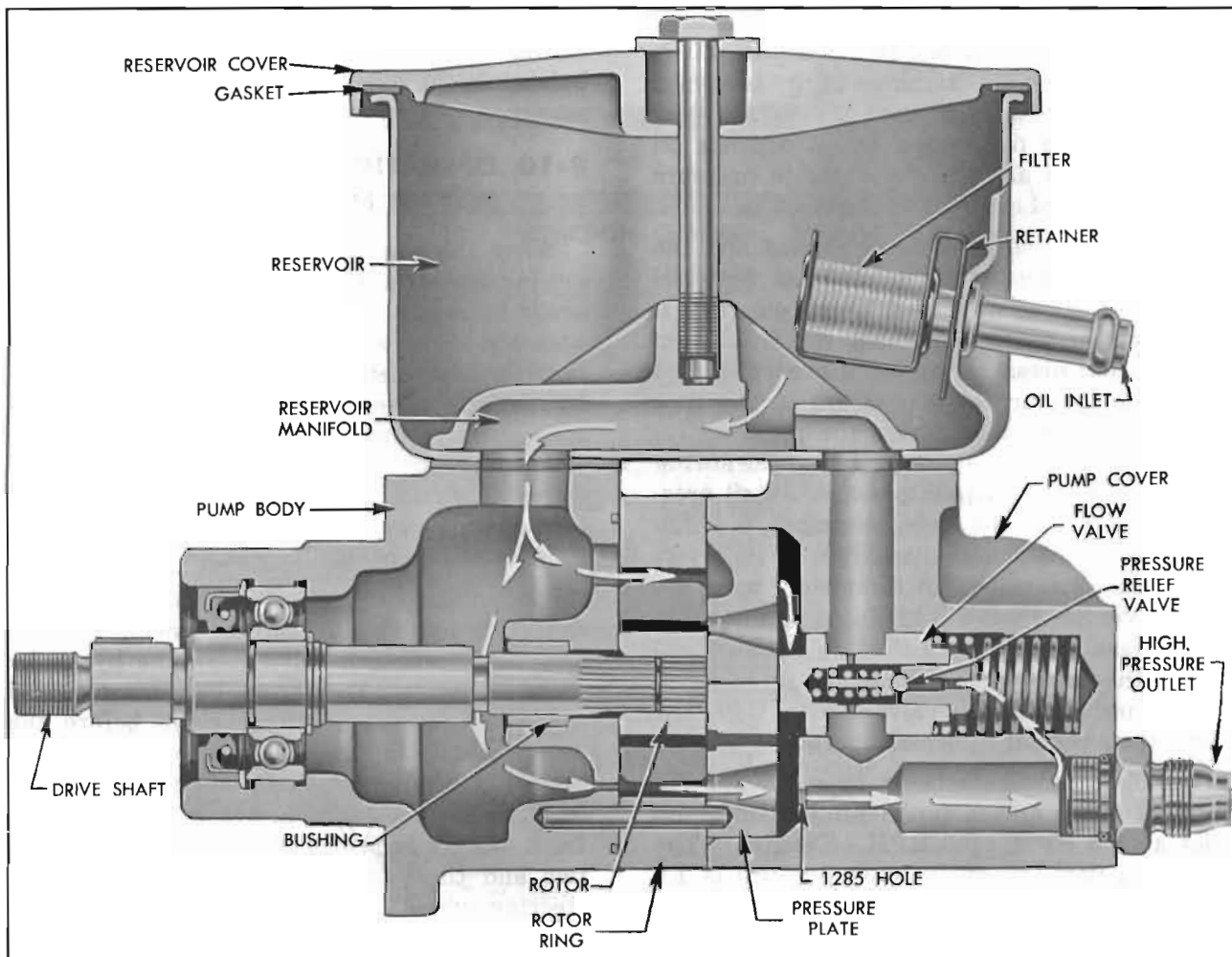

Figure 8-12—Pump Cross-Section

ing is moved down. This in turn moves the actuating lever up or down which is connected to the link on the valve spool. The movement of the actuating lever moves the control valve spool which directs the oil flow through the control valve to the cylinder.

c. Oil Pump

The Saginaw oil pump, which is mounted on the engine in position to be driven by a belt from the crankshaft balancer, converts some engine power into oil pressure which is used by the power cylinder and rack-piston to rotate the pitman shaft.

The pump houses a slotted driving hub or rotor in which ten vanes slide radially outward to contact the hardened and ground inside surface of a ring. As the shaft and rotor rotates, centrifugal force and fluid pressure against the inner ends cause the vanes to follow the cam contour of the ring, which is so shaped

that two opposing pumping chambers are formed. See Figure 8-41. In each pumping chamber, the increasing and decreasing pockets formed between the rotor, vanes, and ring propel the oil from the reservoir into a discharge cavity in the pump cover.

Oil flows from the discharge cavity into the exit port in pump cover through a restricted passage (.1285" dia.); therefore, pressure in the discharge cavity is always greater than that in the exit port. A control valve assembly regulates the opening of another passage through which oil may be by-passed back to the reservoir. See Figure 8-12. The valve assembly includes a flow valve and a pressure relief valve.

When the pump is running without demand for steering pressure, pressure in the discharge cavity is high enough to push the flow control valve open against a spring load of approximately ten pounds. A small orifice leads oil

from the exit port into the spring chamber and this pressure tends to close the valve. Since pressure in the discharge cavity is always greater than in the exit port the valve is not closed, and the flow valve action depends on the spring load and the difference in pressure on the inner and outer ends of the valve.

When power steering is demanded and the steering gear control valve restricts free circulation of oil as described later (par. 8-10), the pump pressure builds up rapidly. When pump output pressure reaches a predetermined maximum the increased pressure in the flow valve spring chamber forces the pressure relief valve open, and oil escapes from the spring chamber into the by-pass passage. As oil pressure is relieved in the spring chamber, the high pressure in the pump discharge cavity overcomes the spring load to completely open the flow valve. See Figure 8-12. Oil is pumped into the by-pass passage until the line pressure opposing the pump drops below the relief valve setting, permitting this valve to close. The flow valve then resumes normal operation.

The flow valve starts to open at 300-400 RPM of pump and is functioning when pump idles at 465 RPM (400 RPM of engine). The minimum flow the pump must produce is 1.5 gal. per minute at 465 RPM against a pressure of 700 psi. The flow valve permits a maximum flow of 2.1 gal. per minute at 1500 RPM against a pressure of 50 psi. The pressure relief valve is set for 975-1075 psi.

d. Reservoir and Hoses

The reservoir is mounted on top of the oil pump and provides a reserve supply of oil to assure complete filling of the hydraulic system. The reservoir is vented at the cover bolt by bleed grooves in the washer which permit escape of any air that may be introduced into the system during assembly of the various units and maintains atmospheric pressure in the reservoir.

In order to remove any foreign matter which may have entered the oil while it passed through the system, a wire mesh filter has been installed in the reservoir through which all the return oil passes prior to its mixing with the oil contained in the reservoir.

A pressure line hose and a return line hose connect the oil pump to the hydraulic valve in the steering gear. See Figure 8-10. The pres-

sure line hose is reduced in size at the valve end to provide a dampening effect on any turbulence in the oil stream.

8-10 OPERATION OF HYDRAULIC POWER MECHANISM

When the steering wheel is turned, the ball nut must move axially along the worm shaft in order to rotate the pitman shaft and thereby turn the front wheels through the connecting linkage. Movement of the ball nut is opposed by the force necessary to turn the front wheels, consequently, the worm shaft tends to move endwise through the ball nut. The ball nut and worm shaft act like a screw jack to thrust a load against the worm thrust bearing, tending to move the bearing.

Movement of the thrust bearing (and worm shaft) is opposed by thrust bearing springs and valve centering springs in the hydraulic valve, therefore, the thrust load must exceed the total preload of the springs before the worm shaft can actually move endwise. Consequently, the worm shaft will move endwise only when the force necessary to turn the front wheels requires an effort of more than two and three-quarters ($2\frac{3}{4}$) pounds at the steering wheel.

a. Neutral or Straight-Ahead

Figure 8-13 shows the valve in the neutral or straight-ahead position and by following the arrows, which indicate oil flow, it is noted that the oil flows from the pump, through the open-center valve and back to the pump reservoir without ever approaching the power cylinder. All passages are open in the neutral position and the valve remains in this position at all times except when effort applied to steering wheel is more than two and three-quarters ($2\frac{3}{4}$) pounds. The valve's "open-center" feature reduces losses to a minimum. It should be understood that the power cylinder is full of oil at all times, although in the straight-ahead position the pressure on both sides of the piston is equal and very low (approximately 15 to 20 psi). This oil acts as a cushion that absorbs road shocks so they are not transferred to the steering wheel, thus giving safer and more effortless driving. In addition, this oil lubricates all internal components of the gear making it unnecessary to grease the gear at any time.

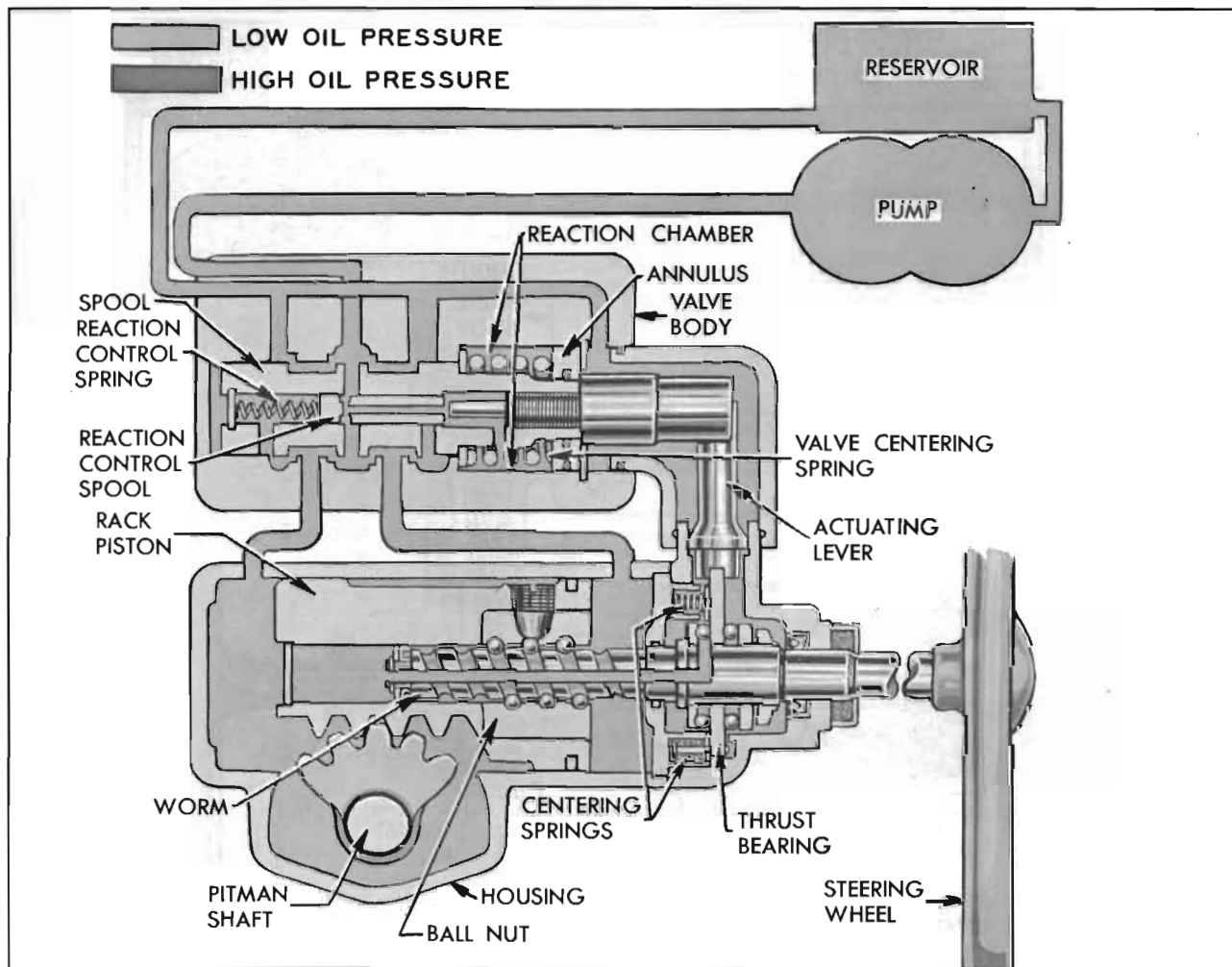

Figure 8-13—Oil Circulation in Neutral or Straight Ahead Position

b. Right Turn

Figure 8-14 illustrates the function of the gear when the steering wheel is turned to the right. Due to the turning resistance, the steering worm tends to screw down into the ball nut; therefore, as the driver applies right turn effort to the steering wheel, the worm is allowed to move downward a slight amount. As the worm moves downward it also moves the thrust bearing downward, which, in turn, causes the valve actuating lever to move the valve spool upward. As this spool moves, the relationship between the grooves in the spool and the grooves in the valve housing is changed so that the lower spool groove is no longer as fully open to return but is opened wider to the pressure side of the pump, and the upper spool groove is opened more fully to return but less fully to the pressure side of the pump. This causes the oil to flow into the lower half of the pressure cylinder and force the piston upward

toward the driver. As the piston moves upward, it moves the power rack with it, which in turn, applies turning effort to the pitman shaft.

The oil in the upper end of the cylinder is simultaneously forced out through the valve and back to the pump reservoir. The higher the turning resistance, the more the valve spool is displaced, and the higher the oil pressure on the lower end of the piston.

c. Left Turn

Figure 8-15 illustrates the function of the gear when the steering wheel is turned to the left. Due to turning resistance the steering worm tends to screw up and out of the ball nut; therefore, as the driver applies left turn effort to the steering wheel, the worm is allowed to move upward a slight amount.

As the worm moves upward it also moves the thrust bearing upward, which in turn causes

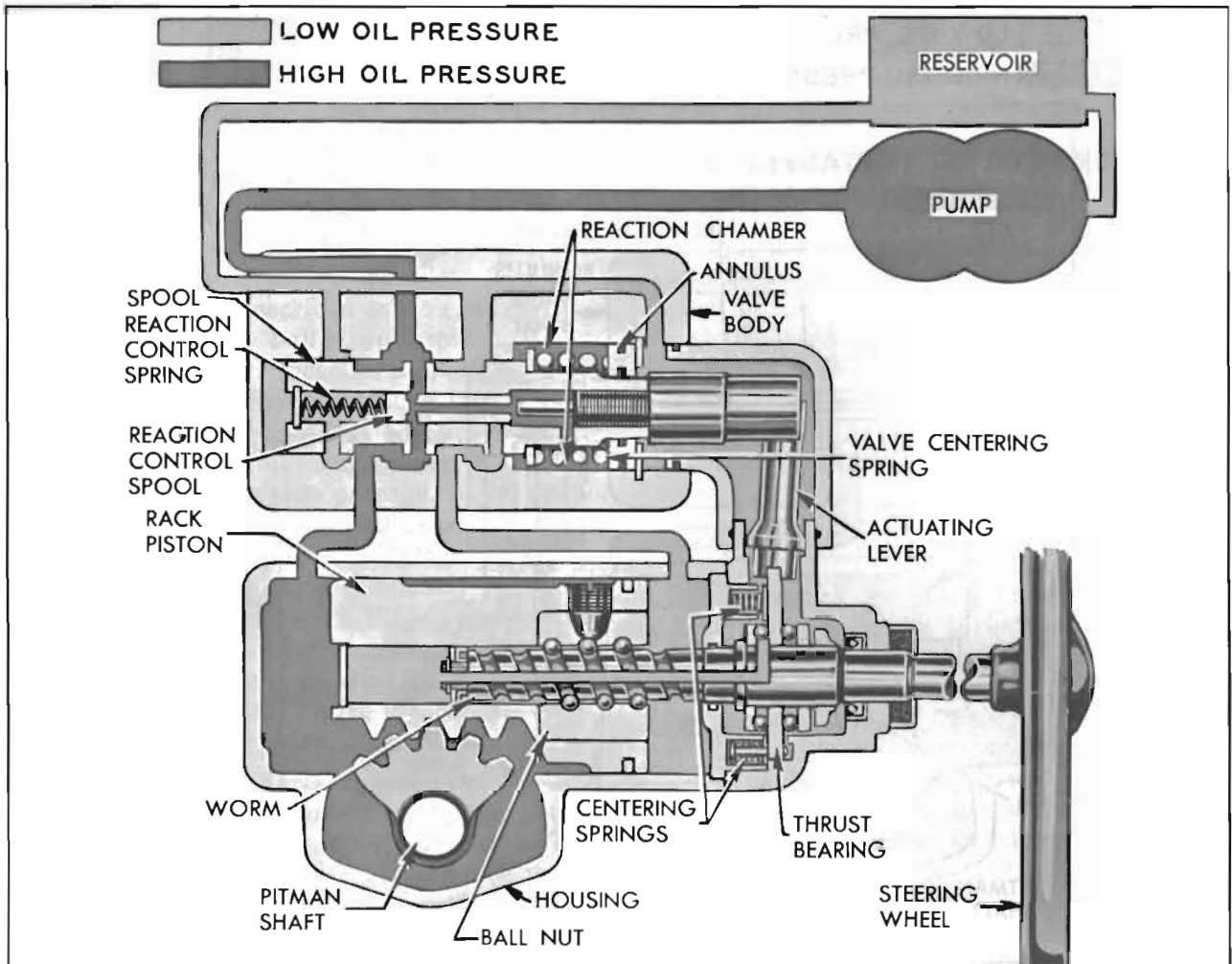

Figure 8-14—Oil Circulation in Right Turn

the valve actuating lever to move the valve spool downward.

As the spool moves, the relationship between the grooves in the spool and the grooves in the valve housing is changed. The upper spool groove is no longer as fully open to return but is opened wider to the pressure side of the pump. The lower spool groove is opened more fully to return but less fully to the pressure side of the pump. This causes the oil to flow into the upper half of the pressure cylinder and force the piston downward away from the driver.

As the piston moves downward, it moves the power rack with it which in turn applies turning effort to the pitman shaft.

The oil in the lower end of the cylinder is simultaneously forced out through the valve and back to the reservoir.

The higher the turning resistance, the more

the valve spool is moved, and the higher the oil pressure on the upper end of the piston.

When oil pressure is directed to the upper end of the rack-piston for a left turn, the oil pressure in this chamber is confined by the oil seal in the adapter, the rack-piston oil rings, and the oil seal on the end of the worm.

To prevent pressure or vacuum at the end of the worm in the rack-piston, this chamber is vented by a passage inside the worm which extends into the end cover chamber.

d. Steering Effort Reaction

The instant the driver stops applying steering effort to the wheel, the valve spool is forced back into its neutral position by three forces; the centering spring in the valve reaction chamber, the centering springs on the thrust bearing, and the hydraulic reaction in the valve reaction chamber. When this happens, the oil pressure is again equal on both

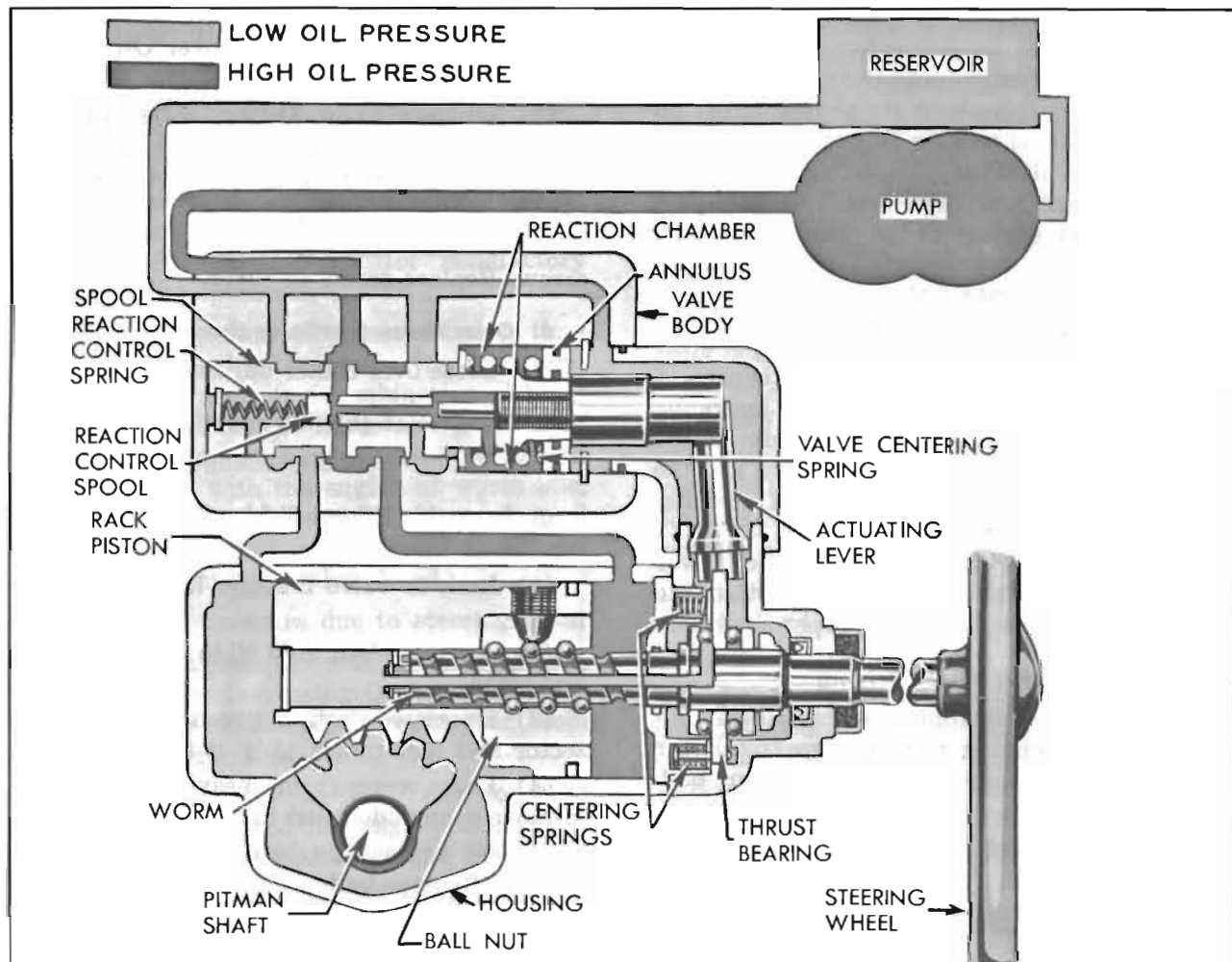

Figure 8-15—Oil Circulation in Left Turn

sides of the piston and the steering geometry of the car causes the wheels to return to the straight-ahead position.

Simultaneously with the turn explained above, oil pressure increases in the valve reaction chamber. This is the feature in the valve that gives the driver the "feel of the road" at all times. As the driver turns to the right and oil pressure builds up in the cylinder, equal oil pressure builds up in this reaction chamber. The more effort required to turn the front wheels, the higher the pressure builds in the reaction chamber. Since it is this pressure that tends to recenter the valve, the driver has to apply more effort to the steering wheel as the pressure in this chamber increases. To summarize, the more the turning resistance, the greater the pressure in this chamber, and therefore, the more effort the driver must apply to the steering wheel to turn the car.

This proportional effort provides the steering "feel."

The amount of pressure that can be built in the reaction chamber is limited to 250 psi by the reaction control spool. As the pressure in the reaction chamber increases, the reaction control spool is forced downward, by this pressure, against the force of the reaction control spool spring until it blocks the oil passage between the reaction chamber and the pump. This passage is blocked at 250 psi in the reaction chamber. If, because of internal leakage past the reaction control spool, the pressure in the reaction chamber should tend to go higher than 250 psi, it would force the reaction control spool slightly further down. When this occurs, the top end of the reaction control spool moves past an oil passage to the relief side of the pump and relieves some of this reaction chamber pressure. This feature insures against

8-18 POWER STEERING

ever building excessive pressures in this chamber.

With 250 psi maximum in the reaction chamber, it only requires about six pounds effort on the steering wheel to turn the car when parking, the most difficult of turning conditions.

Power steering linkage does not have the anti-wheel kick springs at the pitman arm ball.

8-11 TROUBLE DIAGNOSIS—POWER STEERING GEAR AND PUMP

This paragraph covers only those causes of trouble which may be due to the hydraulic power mechanism. Causes which are due to the steering linkage, and front suspension are the same as described for the standard steering gear in paragraph 8-3.

Before assuming that the hydraulic power mechanism is at fault, make certain that the mechanical components are in proper condition.

a. Hard Steering While Driving

(1) Steering adjustment tight. Check adjustment by dropping pitman arm from gear or disconnect linkage from pitman arm ball.

(2) Insufficient pressure build up in power cylinder due to leak or faulty valve. Replace defective parts.

b. Poor Return of Steering Gear to Center

(1) Tight sector to rack-piston adjustment. Adjust in car to specification.

(2) Sticky or faulty control valve. Change valve assembly.

(3) Control valve improperly positioned on steering gear. Loosen control valve screws, allow valve to center itself and retighten screws.

(4) Ball nut and worm pre-load too tight. Remove gear and replace balls as required.

(5) Worm thrust bearing adjustment too tight. Remove gear and adjust to specification.

(6) Sticky valve actuating lever. Free up lever.

c. Momentary Increase in Effort When Turning Wheel Fast to the Right

(1) Air in system. Bleed gear.

d. External Oil Leaks (Wipe gear thoroughly and make sure source of leakage is determined)

(1) Loose hose connection or damaged hose. Tighten or replace.

STEERING GEAR AND LINKAGE

(2) Housing end cover seal, O-ring seal, adapter O-ring seal, or side cover O-ring seal. Replace seal.

(3) Linkage cover O-ring seals, valve to gear housing O-ring seals. Replace seal.

(4) Pitman shaft seal and valve end plug O-ring seal. Replace seal.

(5) Pitman shaft over center adjustment screw. Replace screw in cover.

e. Gear Noise (rattle or chuck)

(1) Loose over center adjustment.

f. Gear Noise (hissing sound)

(1) If objectionable, change valve.

g. Excessive Wheel Kickback or Loose Steering

(1) Lash in valve linkage. Replace affected parts.

(2) Air in system. Add oil to pump reservoir and bleed.

(3) Excessive lash between pitman shaft sector and rack-piston. Adjust to specification.

(4) Loose worm thrust bearing adjustment. Remove gear and adjust to specification.

(5) No preload on ball nut and worm assembly. Replace balls as required.

(6) Ball nut retaining screw loose in piston. Replace screw and restake securely.

h. Steering Wheel Surges or Jerks When Turning with Engine Running

(1) Loose pump belt. Adjust to specification.

i. Hard Steering When Parking

(1) Loose pump belt. Adjust to specification.

(2) Low oil level in reservoir. Fill to proper level. If excessively low, check all lines and joints for evidence of external leakage.

(3) Steering gear adjustments tight. Adjust to specifications.

(4) Insufficient oil pressure. If all the above checks do not reveal the cause of hard steering, make the following test of oil pressure:

a. Disconnect the pressure line at oil pump, attach gauge to pump, connect the hose to end of gauge where the valve is located.

b. With engine at warm idle and gauge valve open, note the oil pressure on the gauge while turning steering wheel from one extreme position to the other. Especially note the maximum pressure which can be built up with the wheel

held in either right or left extreme position.

CAUTION: *Do not hold wheel in extreme position for an extended period of time because it will drastically increase the oil temperature and will cause undue wear on the oil pump.*

c. With oil temperature between 150°F and 170°F, as measured with a thermometer in the reservoir, the minimum oil pressure at idle should be at least 875 psi for satisfactory power steering operation.

d. If the maximum oil pressure is less than 875 psi, it indicates trouble in the pump, oil hoses, steering gear, or a combination of these parts. To eliminate the hoses and gear, close the gauge valve and quickly test pressure of the pump only, with the engine at warm idle, then open the valve to avoid increasing oil temperature. A minimum pressure of 875 psi should be present with valve closed.

(5) Low oil pressure due to steering gear.

a. Leakage at adapter seal, adapter O-ring, worm seal, valve-to-housing O-ring, side cover O-ring, pitman shaft seal. Remove gear from car for replacement of seals.

b. Pressure loss in cylinder due to worn piston rings or scored housing bore. Remove gear from car for disassembly and inspection of seals, rings and housing bore.

c. Pressure loss in control valve due to annulus O-rings or leakage between spool and body. Replace annulus O-rings or valve assembly as necessary.

(6) Hydraulic reaction relief spool in center of valve spool not functioning. Replace valve assembly.

8-12 REMOVAL AND INSTALLATION OF PITMAN SHAFT SEAL, STEERING GEAR AND PUMP

a. Removal and Installation of the Pitman Shaft Seals with Steering Gear in Car

If, upon inspection of the gear, it is found that oil leakage exists at the pitman shaft seals, the seals may be replaced without removing gear from car by performing the following:

1. Disconnect pitman arm from gear.
2. Thoroughly clean end of pitman shaft and housing, then tape splines on end of pitman shaft to insure that seals will not be cut by splines during disassembly and assembly.

NOTE: *Only one layer of tape should be used; an excessive amount of tape will not allow the seals to pass over it, due to the close tolerance between the seals and the pitman shaft.*

3. Remove pitman shaft seal retaining ring with No. 3 Truarc pliers J-4245.

4. Start engine and turn steering wheel to the right until oil pressure in the housing forces out the seals. Turn off engine. **NOTE:** *Use suitable container to catch oil forced out of gear. This method of removing the pitman shaft seals is now recommended, as it eliminates the possibility of scoring the housing while attempting to pry it out.*

5. Inspect seals for damage to rubber covering on O.D. If O.D. appears scored, inspect housing for burrs and remove before attempting new seal installation.

6. Clean the end of housing thoroughly so that dirt will not enter housing with the installation of the new seals.

7. Lubricate the seals thoroughly with petroleum jelly and install seals with Installer J-6219. See figure 8-23. **CAUTION:** *When driving seal into housing with Tool J-6219, it is important to place steel back-up washer between installer and seal so that driving force may be transmitted through washer to seal, preventing possibility of seal caving in due to round shoulder on O.D. of tool. Also, care should be taken to see that snap ring is fully seated in housing groove with beveled side out.*

8. Fill reservoir to proper level, start engine and turn wheel to right and check for leaks.

9. Remove tape and reinstall pitman arm.

b. Removal of Power Steering Gear

1. Place fender cover over left front fender.
2. Disconnect the pressure and return line hoses at the steering gear and elevate ends of the hoses higher than pump to prevent oil from draining out of pump.
3. Mark upper and lower steering shaft flanges for correct assembly. Then disconnect the flexible coupling. See figure 8-16.
4. Jack up car and remove the pitman shaft nut, then remove the pitman arm.
5. Remove the four steering gear to frame bolts at outside of left frame rail.
6. Remove steering gear.

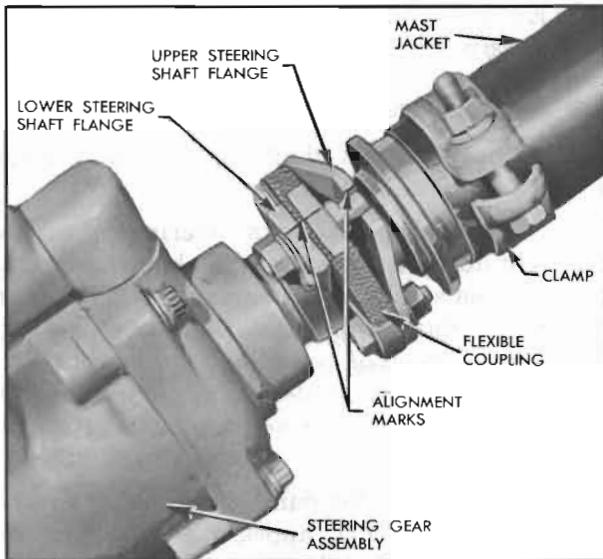

Figure 8-16—Marking Flexible Coupling

c. Installation of Steering Gear Assembly

1. Install the gear assembly by reversing the procedure for removal.
2. Fill the reservoir with Dynaflo oil (engine stopped). *NOTE: Make sure that all hose connections are tight.*
3. Start engine to run pump. Maintain proper oil level in the reservoir by adding oil as required.
4. When oil level remains constant, rotate the steering wheel through its entire range slowly a few times.
5. Recheck oil level, and replace reservoir cover.

d. Removal, Installation and Bleeding of Oil Pump

1. When removing the pump, use shipping plugs and caps to cover the hose connectors and unions on pump and plug open ends of the pressure and return line hose to avoid entrance of dirt.
2. When pump is installed on mounting bracket, adjust drive belt tension by using a torque wrench applied to the pulley nut. With a *new* belt, the tension should be set so that the pulley will slip in belt when 40-45 ft. lbs. torque is applied to pulley nut. With a *used* belt the torque should be 30-35 ft. lbs.
3. Fill the reservoir to proper level with specified Dynaflo oil. Start engine to run pump. Maintain oil level in reservoir by adding if necessary.

4. When oil level remains constant, jack up front end of car and rotate the steering wheel through its entire range slowly a few times without causing power assistance. Stop engine, let car down, check oil level and correct if necessary and replace reservoir cover.

8-13 ADJUSTMENT OF PITMAN SHAFT AND STEERING LINKAGE

a. Adjustment of Pitman Shaft with Power Steering Gear in Car

1. Disconnect pitman arm from intermediate tie rod and check tightness of pitman arm nut with an 18" wrench.

NOTE: Never attempt to adjust steering gear with pitman arm connected to intermediate rod.

2. Turn steering wheel slowly through its full travel to check for binding, tight spots or uneven action.
3. Turn steering wheel to extreme right or left position. Apply Scale J-544-A to a spoke at rim of wheel and, while pulling scale at 90 degrees to spoke, check the pull required to turn the wheel steadily in the range *where lash normally exists* between ball nut and pitman shaft sector. The lash range exists for one eighth turn of steering wheel from either extreme position.
4. The reading on the scale should be between $\frac{1}{4}$ and $\frac{1}{2}$ pound, which would indicate normal loading or drag at the thrust bearing.
5. Loosen pitman shaft adjusting screw lock nut and turn adjusting screw counterclockwise a few turns.
6. Check the pull required to turn the wheel through the "high-point" or no lash range. The reading should be $\frac{1}{4}$ to $\frac{3}{4}$ lb. higher than previous reading, which would indicate normal ball nut preload.

7. If readings are not within specifications, remove power steering gear and recheck adjustment on bench as outlined in paragraph 8-13 (b).

8. If readings are within specifications, turn pitman shaft adjusting screw clockwise as required to obtain a scale reading $\frac{1}{2}$ to 1 pound *higher* than was obtained in step 6. This reading is taken when pulling wheel through "high-point" with lock nut tight. Total reading should be between $1\frac{1}{4}$ to $1\frac{3}{4}$ lbs.

b. Adjustment of Pitman Shaft with Power Steering Gear Removed

Adjustment of pitman shaft can also be made on bench with power steering gear completely assembled.

1. Place power steering gear assembly in vise with wormshaft up. See Figure 8-17. Install Over Center Adjuster J-6281 on flexible coupling.

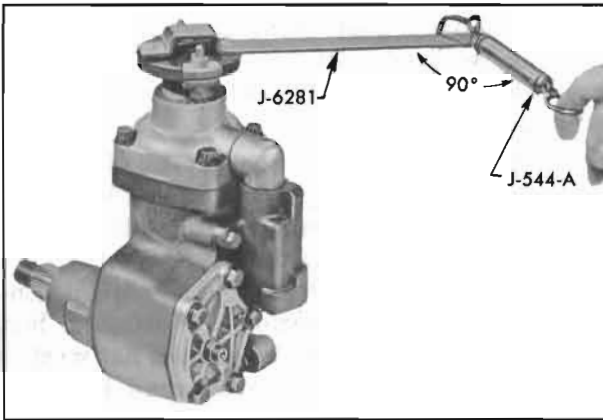

Figure 8-17—Pitman Shaft Adjustment

2. Turn wormshaft to extreme right or left position. Apply scale J-544-A to Over Center Adjuster Tool, and while pulling scale at 90 degrees to tool, check the pull required to turn the wormshaft in the lash range. (One eighth turn of wormshaft from either extreme position.)

3. The reading on the scale should be between $\frac{1}{4}$ to $\frac{1}{2}$ lb. If readings are not within specifications, it will be necessary to readjust thrust bearing preload.

4. Back off pitman shaft adjusting screw lock nut and turn adjusting screw counterclockwise a few turns.

5. Check the pull required to turn the gear through "high point" or "no lash" range. The reading should be $\frac{1}{4}$ to $\frac{3}{4}$ lb. higher than reading obtained in step 3. If reading is not within specifications it will be necessary to readjust ball nut preload (paragraph 8-16d).

6. If readings are within specifications, turn pitman shaft adjusting screw clockwise as required to obtain a scale reading $\frac{1}{2}$ to 1 lbs. higher than was obtained in step 5.

This reading is taken when pulling the Over Center Adjuster through "high-point" range with lock nut tight. Total reading should be $1\frac{1}{4}$ to $1\frac{3}{4}$ lbs.

c. Adjustment of Steering Linkage

Steering linkage adjustments for manual and power steering are the same with one exception.

On the power steering linkage, the pitman arm end plug adjustment is made in the same manner as idler arm end.

Refer to paragraph 8-4(b) for steering linkage adjustment.

8-14 DISASSEMBLY, INSPECTION, ASSEMBLY OF CONTROL VALVE ASSEMBLY

a. Removal of Control Valve Assembly

1. Thoroughly clean exterior of gear assembly with a suitable solvent and drain the unit by placing control valve down and turning the worm shaft through its entire range two or three times.

2. Remove the control valve retaining bolts and lift control valve and linkage cover off the gear housing. Pull the linkage cover out of the valve body. See Figure 8-18.

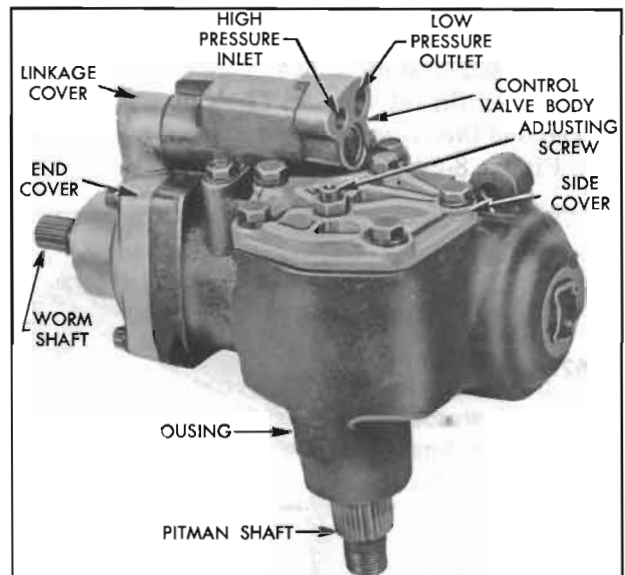

Figure 8-18—Right Side of Power Steering Gear Assembly

b. Disassembly of Control Valve Assembly

NOTE: Disassembly of the valve spool assembly should normally not be performed unless there is evidence of faulty operation. The valve link contains a nylon pin located in the threaded part. This pin acts as a lock and prevents the valve spool from threading itself out of the valve link. The locking action of this pin will be lost after more than one or two disassemblies.

8-22 POWER STEERING**STEERING GEAR AND LINKAGE**

1. Remove annulus retaining snap ring using No. 1 Truarc Ring Pliers J 5403 and annulus retaining washer. Then slide spool assembly out of the valve body. Care should be taken to see that neither the spool assembly or the valve body are scratched or dropped. See Figure 8-19.

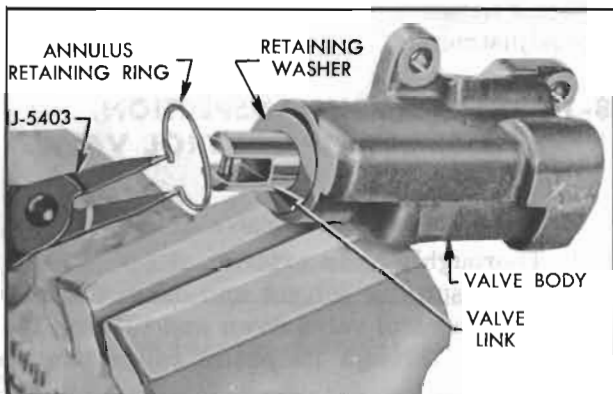

Figure 8-19—Removing Annulus Retaining Snap Ring

2. Clamp the spool assembly in a vise on the small end. **DO NOT CLAMP THE SPOOL ON THE LARGE FINISHED DIAMETER.** Remove the valve link using Remover and Replacer J 6224, annulus, valve centering spring, and spring thrust washer. Then turn spool over to remove the reaction control spool and spring. See Figure 8-20.

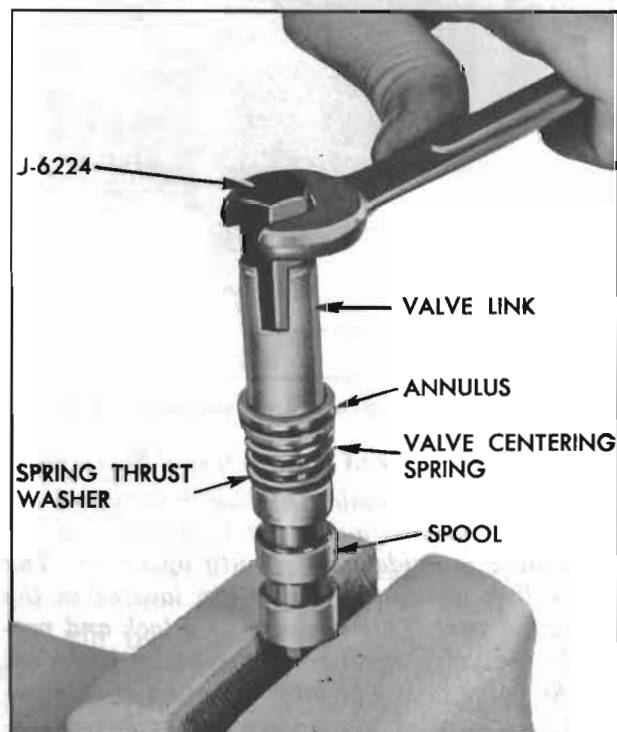

Figure 8-20—Removing Valve Link

3. Remove retaining ring using No. 1 Truarc Ring Pliers J 5403, and tap end plug from valve body with a wood drift being careful not to damage the inside diameter of the valve body.

c. Inspection of Control Valve Assembly

1. Inspect inside of valve body and both spools for scores, nicks, or burred edges. If either the valve body or one of the spools is damaged, a complete control valve assembly must be replaced as the valve body and spools are selective fits and therefore are available only as an assembly.

2. Inspect the hose connectors. If badly brinelled or scored, replacement will be necessary. To remove the connectors, tap threads in the hole using a $\frac{5}{16}$ -18 tap in the large connector and a No. 12-24 tap in the small connector. Pull the connector by using a bolt threaded into the tapped hole and a flat washer and nut as an extractor. Wash and blow the valve body out thoroughly to remove any tapping chips. To replace the connector, use Replacer J 6217 to drive the connector in place.

d. Reassembly of Control Valve Assembly

1. Thoroughly clean all the parts and lubricate the internal parts with dynaflo oil. Then clamp spool in vise in same manner as in disassembly, and install reaction control spring and spool with narrow land next to spring. Assemble spring thrust washer and valve centering spring on the spool. Lubricate new annulus O-ring seals with petroleum jelly and install on annulus. Assemble annulus on spool with narrow land of annulus toward spring.

2. Hold annulus down on spool to compress the spring. Then assemble link and tighten to 8-10 ft. lbs. using Remover and Replacer J 6224. See Figure 8-21. Remove the spool as-

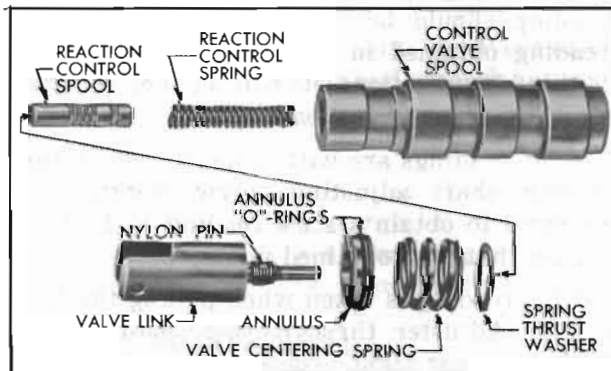

Figure 8-21—Control Valve Spool Assembly

sembly from vise. Carefully insert the spool assembly into the valve body. The spool and valve body are selective fits and have very little clearance. Only if properly started can the spool be assembled. **DO NOT ATTEMPT TO FORCE THE SPOOL INTO THE VALVE BODY.**

3. Install the annulus retaining washer with chamfered side down, and retaining snap ring with beveled side up using No. 1 Truarc Pliers J 5403. Make certain that the retaining ring is properly seated.

4. Install new O-ring on end plug and install end plug in valve body. Then install end plug retaining snap ring with beveled side up using No. 1 Truarc Pliers J 5403. Make certain that the retaining ring is properly seated.

e. Installation of Control Valve Assembly

1. Lubricate new linkage cover O-ring seal and install on linkage cover. Assemble linkage cover to control valve. Position valve link so that slot is perpendicular with the bottom of valve.

2. Install the two small new O-ring seals on gear housing and new O-ring seal on end cover. Position control valve and linkage cover over gear housing and end cover. Start actuating lever into the link slot and then push down on the linkage cover until the valve is seated on the housing.

3. Install control valve retaining bolts and tighten to 15-20 ft. lbs. Tighten the bolt on lower end of control valve first. **BE SURE NOT TO FORCE THE VALVE IN EITHER DIRECTION WHILE TIGHTENING BOLTS AS THIS WILL CAUSE MALFUNCTIONING OF THE VALVE.**

8-15 DISASSEMBLY, INSPECTION, ASSEMBLY OF PITMAN SHAFT ASSEMBLY

a. Removal of Pitman Shaft Assembly

1. Remove control valve assembly as outlined in Paragraph 8-14 (a).

2. Remove side cover retaining bolts and rotate cover one-half turn. Align pitman gear with opening in gear housing by turning worm shaft. Tap the end of pitman shaft with a soft mallet and remove pitman shaft from housing.

b. Disassembly of Pitman Shaft Assembly

1. Hold pitman shaft adjusting screw with an Allen head wrench and remove adjusting screw

locknut and discard. Turn the screw out of cover and remove cover. Cut off or push up staked portion of lash adjusting screw retainer. Remove retainer and adjusting screw and discard both. A nylon pin in the adjusting screw prevents any loss of fluid past the threads. Whenever the adjusting screw is removed this pin is damaged and a new adjusting screw should be installed. Remove adjusting screw washer from bore in pitman shaft.

2. Remove the pitman shaft seal retaining snap ring from end of housing using No. 3 Truarc Pliers J 4245 and seal back-up washer. To remove shaft oil seals, tap an offset screw driver in between seals and shoulder in gear housing, then pry seals out of housing being careful not to damage the seal bore in housing. **NOTE: It is recommended to use the method outlined in Paragraph 8-12(a) for removal of pitman shaft seal.**

c. Inspection of Pitman Shaft Assembly

1. Inspect pitman shaft bearing surface in side cover for excessive wear or scoring. If worn or scored replace side cover.

2. Check pitman shaft sector teeth and bearing surfaces. If worn, pitted, or scored, replace shaft. Then check the pitman shaft bore in housing for wear. If worn, the housing should be replaced.

d. Reassembly of Pitman Shaft Assembly

1. Place adjusting screw washer in bore in pitman shaft, lubricate head end of new adjusting screw with petroleum jelly and place it in bore.

2. Install new adjusting screw retainer, turning it down so adjusting screw is free to turn, but has no perceptible end play. Stake retainer securely into slot in pitman shaft in two places. See Figure 8-22.

2. Assemble the side cover on pitman shaft. Screw the new adjusting screw through side cover until the side cover bottoms on the pitman shaft.

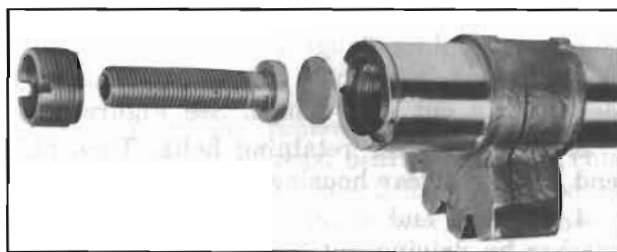

Figure 8-22—Lash Adjusting Screw

e. Installation of Pitman Shaft Assembly

1. Turn worm shaft as necessary until the center groove of the rack-piston is aligned with center of pitman shaft bushing. Install pitman shaft so that the center tooth in the sector meshes with the center groove of rack-piston. Make sure that new side cover O-ring is in place, then push the side cover down on gear housing.

2. Install and tighten the four $\frac{3}{8}$ " side cover bolts to 25-30 ft. lbs. Install and tighten the $\frac{5}{16}$ " side cover bolt to 15-20 ft. lbs. Then install adjusting screw lock nut.

3. To prevent damage to pitman shaft oil seals, fully cover pitman shaft splines with tape. Use only a single layer of tape.

4. Lubricate the seals thoroughly with petroleum jelly and install as per paragraph 8-12 step 7. See Figure 8-23.

5. Install control valve assembly as outlined in Paragraph 8-14 (e).

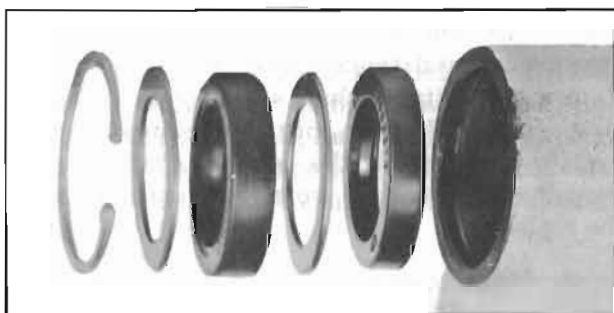

Figure 8-23—Pitman Shaft Seal Assembly

8-16 DISASSEMBLY, INSPECTION, ASSEMBLY OF RACK-PISTON AND WORM ASSEMBLY

a. Removal of Rack-Piston and Worm Assembly

1. Remove control valve assembly as outlined in Paragraph 8-14 (a) and pitman shaft as outlined in Paragraph 8-15 (a).

2. Pull actuator lever out of end cover and remove flexible coupling and mark coupling flange and worm shaft before disassembly. Support coupling flange and remove coupling flange and felt washer from worm shaft by driving pin out with punch. See Figure 8-24.

3. Remove cover retaining bolts. Then pull end cover off gear housing.

4. Remove end cover oil seal and back-up washer by driving out with a small punch or screwdriver.

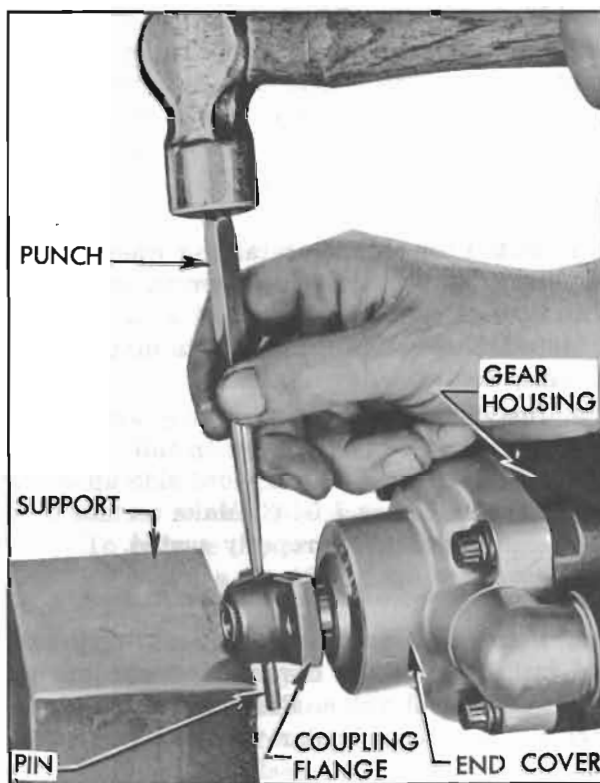

Figure 8-24—Removing Coupling Flange

5. Remove four loose centering springs and pull rack-piston and worm assembly out of housing. See Figure 8-25.

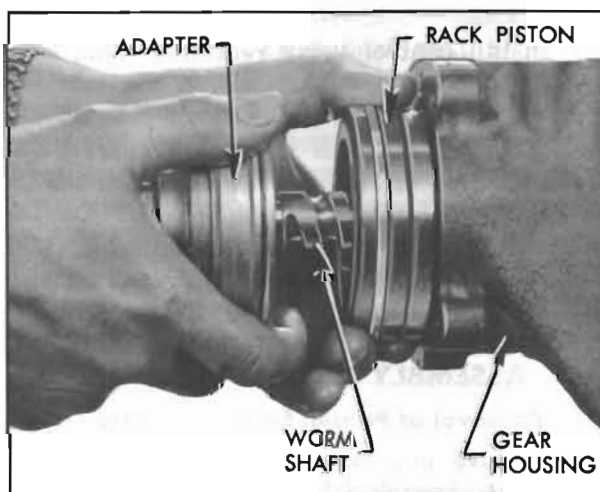

Figure 8-25—Removing Rack-Piston and Worm Assembly

b. Disassembly of Rack-Piston and Worm Assembly

1. Remove piston ring from rack-piston. Unstake and remove ball nut retaining screw using Allen wrench and slide the ball nut and worm assembly out of rack-piston with ball nut

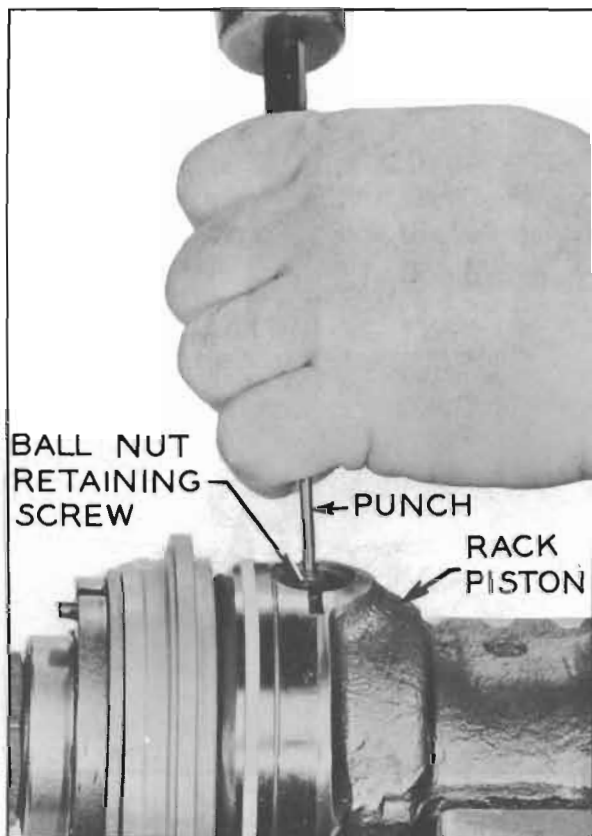

Figure 8-26—Un-Staking Ball Nut Retaining Screw

retaining screw hole down to prevent ball return guides from falling out and losing balls.

2. Remove the ball return guides. Turn the nut with the ball return guide holes down. Rotate the worm back and forth until all the balls have dropped out of the nut. Catch the balls in a clean pan or cloth. Remove the ball nut and the adapter from the worm. Remove thrust bearing centering springs from the adapter. See Figure 8-27.

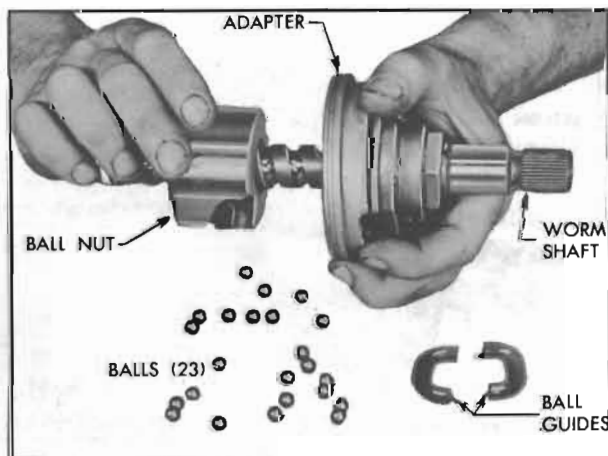

Figure 8-27—Removing Balls from Ball Nut

3. Remove the adapter seal retaining ring with pointed tool. Remove seal back-up washer, and adapter seal.

4. Cut the Teflon seal at end of worm and remove from worm. Push the retaining ring washer toward the worm groove and remove the retaining ring. Remove the retaining ring washer, bronze back-up washers, and steel washer.

c. Inspection of Rack-Piston and Worm Assembly

1. Inspect the worm and ball nut grooves and all the balls for wear or scoring. If either the worm or ball nut needs replacing, both must be replaced as a matched assembly.

2. Inspect ball return guides, making sure that the ends where the balls enter and leave the guides are not damaged.

3. Inspect the rack-piston teeth for pitting, wear, and scoring. Inspect all bearing surfaces on rack-piston for scoring. Do not remove rack-piston end plug unless it is loose. To replace plug, drive old plug out from inside rack-piston, press new plug in flush with end of rack-piston and stake securely in four places. Inspect retaining screw threads in rack-piston and tap out if necessary.

4. Inspect housing bore. If badly scored or worn, replace housing. Inspect housing end plug for leakage. Unless there is visual evidence of leakage, do not remove end plug. To remove end plug, the staked portion must be either pushed up or cut off so that the plug may be driven into the housing without scoring the sealing diameter. To replace the end plug, lubricate a new plug O-ring seal and install on a new end plug. Install end plug in housing from the inside and stake plug securely in four places. Inspect the pitman shaft bore and if badly worn, replace housing.

5. Inspect the thrust bearing centering springs. If any of the four springs riveted to the thrust bearing are broken, the thrust bearing assembly must be replaced. If any of the four loose springs are broken, replace all four.

6. Check for roughness by holding the worm stationary and rotating the center race. If the bearing is rough, replace thrust bearing assembly. Check the thrust bearing preload. This should be between $\frac{3}{4}$ and 3 lbs. measured at the outer edge of the center bearing. To measure bearing preload, clamp the worm in a vise using soft jaws. Fasten a cord to one of the

riveted centering springs and wind it around the center race. Attach the other end of the cord to Spring Scale J-544-A. Then slowly pull the other end of the scale and check the reading. If the preload is not within the limits, push the staked portion of the thrust bearing nut up out of the thread groove, being careful not to damage the thread, and remove the nut and discard. Use a new nut and adjust as necessary to obtain proper preload. After the proper preload has been obtained recheck bearing for roughness and stake the nut being careful not to move the nut when staking. Recheck the preload after staking. See Figure 8-28.

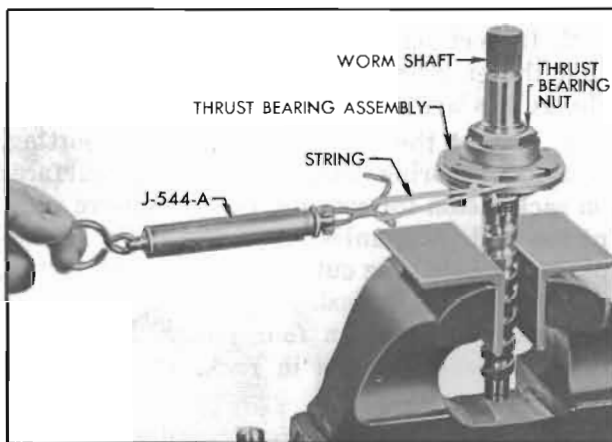

Figure 8-28—Checking Thrust Bearing Preload

7. Inspect the end cover for wear in the actuator lever bore. If badly worn, replace the end cover. Inspect the end cover needle bearing. If needles are pitted or worn, replace the bearing. To remove the bearing, use Remover and Replacer J 6221 and drive the bearing out. To install the bearing use Remover and Replacer J. 6221 with the identification marks of bearing against shoulder of tool. Drive the bearing flush with outer end of the cover. See Figure 8-29. Pack bearing with chassis grease after installing in end cover.

d. Reassembly of Rack-Piston and Worm Assembly

1. Thoroughly clean, oil the parts, and lubricate the internal parts with dynaflo oil. Use only new seals and gaskets during assembly.

2. Lubricate O-ring and install on adapter. Lubricate and install adapter oil seal with black rubber side out, then install seal back-up washer and retaining ring. Assemble adapter to worm being careful not to damage the seal

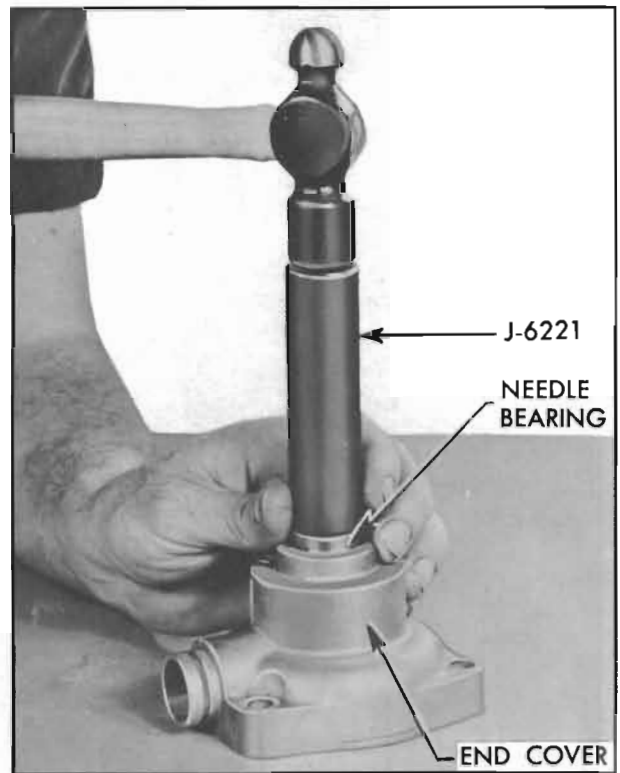

Figure 8-29—Installing End Cover Needle Bearing

when passing over the worm grooves. Slide the ball nut with the chamfered edge away from the adapter over the worm up to the adapter.

3. Align the ball return guide holes with the worm groove. Load 17 balls into the ball nut. Drop the balls into the return guide hole farthest from the adapter while slowly rotating the worm counterclockwise to feed the balls through the circuit. See Figure 8-30.

4. Fill one-half of the ball return guide with the remaining six balls. Place the other half of the guide over the balls and plug each end

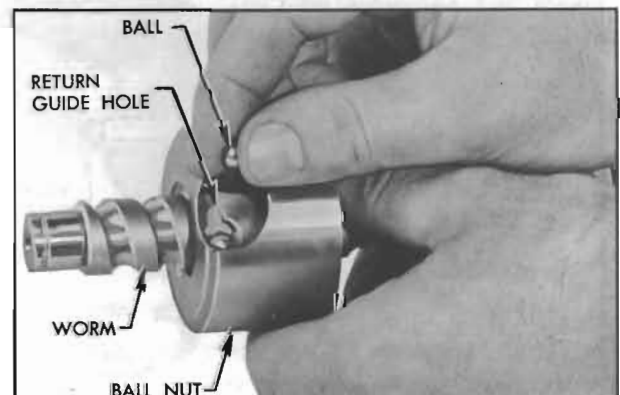

Figure 8-30—Loading Balls in Ball Nut

with heavy grease to prevent the balls from falling out when installing the guide into the ball nut."

5. Push guide into guide holes of the ball nut. If the guide does not push down easily, tap it lightly with a soft mallet to seat it. Wrap a strip of tape around the ball nut and guide to prevent the guide from falling out. See Figure 8-31.

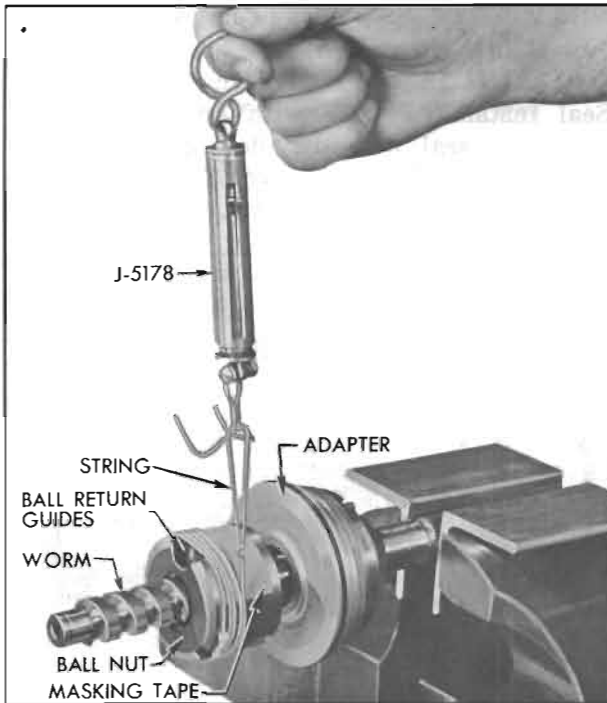

Figure 8-31—Checking High Point Preload

6. The worm groove is ground with a high point in the center. When the ball nut passes over this high point, a preload of 1 to 6 lbs. measured at the edge of the ball nut should be obtained. To measure the preload, clamp the splined end of the worm in a bench vise using copper jaws, fasten a cord to the ball nut and wind it around ball nut two or three times. Attach Spring Scale J 5178 to other end of cord, and slowly pull the other end of scale, unwinding the cord and rotating ball nut over the high point of worm. The highest reading obtained, after nut has started to rotate should be between 1 to 6 lbs. If the load is too small, disassemble and reassemble the next larger ball size and recheck. The ball size is stamped on the end of the ball nut and balls are available in 13 sizes, numbered 1 through 13. If the preload is too great, use

the next smaller ball size and recheck. See Figure 8-31.

7. Install steel washer, Teflon seal with rubber toward worm, bronze back-up washer, retaining ring washer, and seal retaining ring on end of worm. Then lubricate the Teflon seal with dynaflo oil. See Figure 8-32.

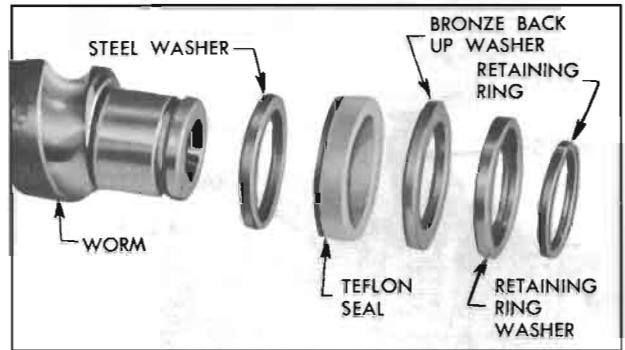

Figure 8-32—Worm Seal Assembly

8. Remove tape from the ball nut and install the worm assembly into rack-piston with ball nut retracted against adapter. The retaining screw hole should be down and aligned with the screw hole in rack-piston. Use care to prevent damage to worm seal. See Figure 8-33.

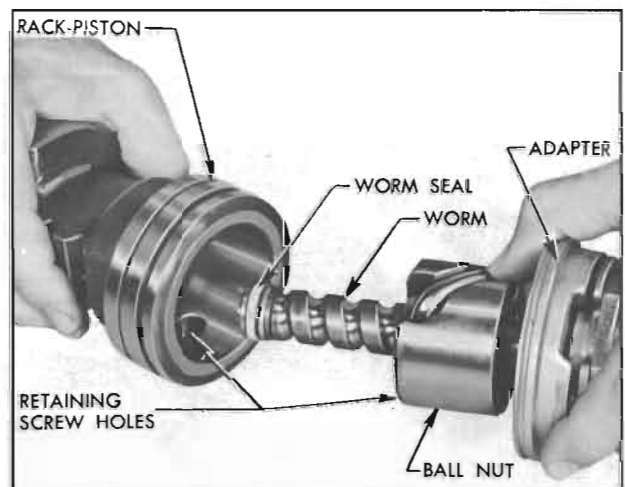

Figure 8-33—Installing Worm Assembly in Rack-Piston

9. Install the ball nut retaining screw using Allen wrench and tighten to 30 to 35 ft. lbs. Stake screw securely using Staking Tool J 6285. See Figure 8-34.

10. Install the Teflon piston ring on the rack-piston and lubricate with dynaflo oil.

11. Install Piston Ring Compressor J 6216 and hold tightly against shoulder in housing. Then push the rack-piston assembly into the

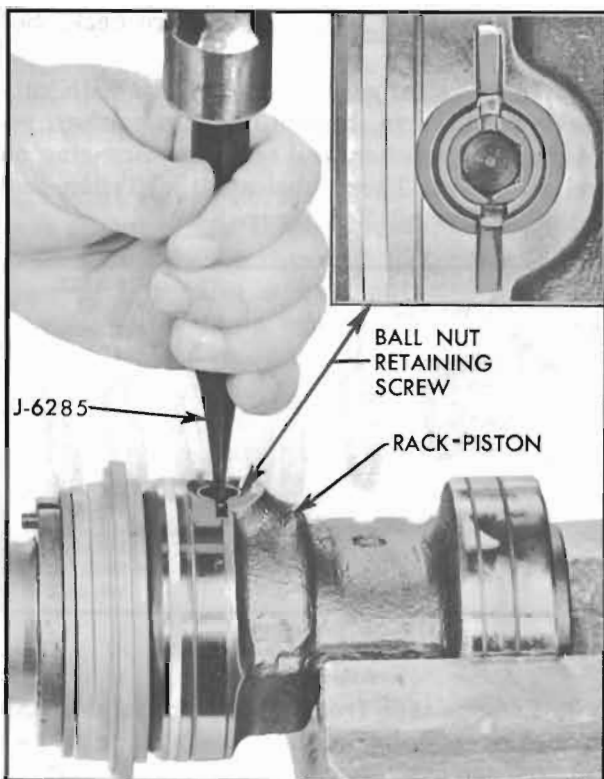

Figure 8-34—Staking Ball Nut Retaining Screw

housing with rack-piston assembly toward end of worm until the piston ring stops against end of cylinder. Carefully push ring back in groove

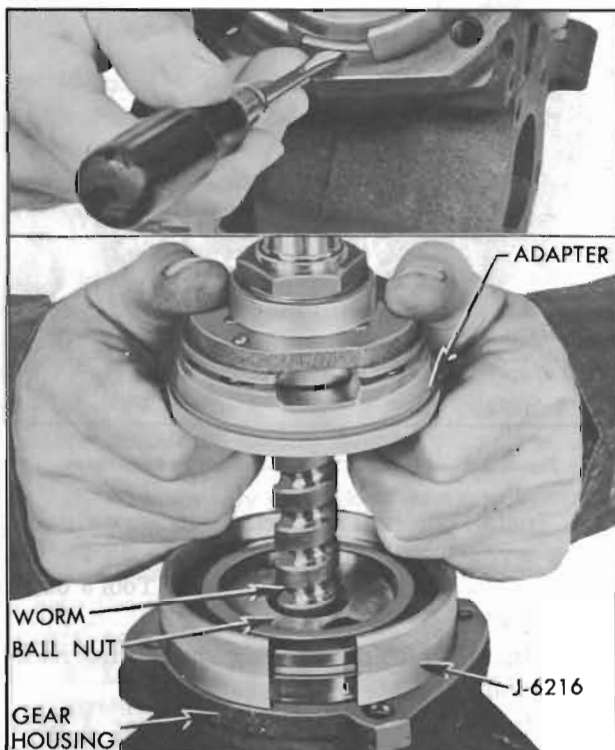

Figure 8-35—Installing Rack Piston with Teflon Ring

with small screw driver while using moderate pressure against end of piston. See Figure 8-35.

12. Remove piston ring compressor. Align the actuator lever relief slot in the adapter with the valve mounting face on housing. Push the rack-piston into the housing until the adapter with O-rings is seated in the housing counterbore. Install the four valve centering springs between the adapter and thrust bearing.

13. Install new seal back-up washer in end cover with chamfered side first. See Figure 8-36. Press in new end cover oil seal using Seal Installer J 5188 with lips toward tool. Lubricate seal with dynaflow oil and install new O-ring seals on end cover. Lubricate needle bearing with chassis lubricant.

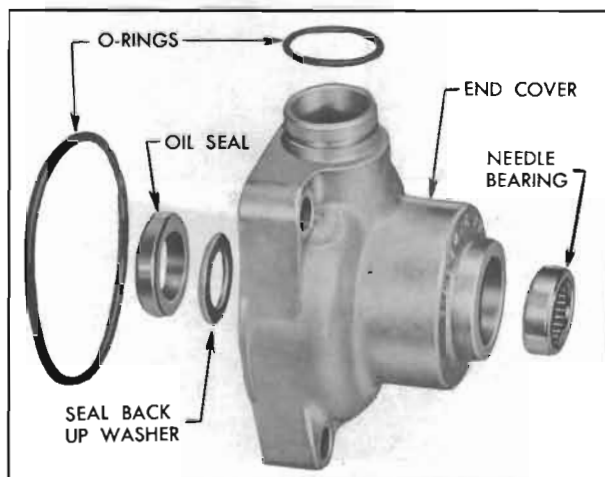

Figure 8-36—End Cover Bearing and Seal Assembly

14. Install Seal Protector J 6222 over worm serrations to prevent damage of end cover seal. See Figure 8-37. Assemble end cover over worm and adapter making certain that adapter pin enters pilot hole in end cover. Align end cover holes with housing holes and install retaining bolts. Tighten bolts evenly to 25 to 30 ft. lbs.

15. Install actuating lever in end cover making certain that it is seated over the thrust bearing center race. The actuating lever should install freely into the end cover bore.

16. Installing coupling on worm spline as marked during disassembly and drive pin in place. Then install flexible coupling.

17. Install pitman shaft and control valve as outlined in Paragraph 8-15 (e), and Paragraph 8-14 (e).

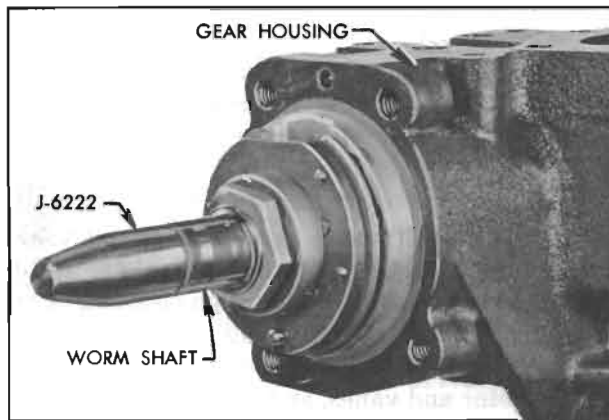

Figure 8-37—Seal Protector Installed on Worm Shaft

18. Adjust Pitman shaft, as outlined in Par. 8-13 (b).

8-17 DISASSEMBLY, INSPECTION, ASSEMBLY OF SAGINAW OIL PUMP

a. Disassembly of Saginaw Oil Pump

1. Use shipping caps to cover the hose unions on pump to exclude dirt, then thoroughly clean exterior of pump.

2. Remove reservoir cover, drain out all oil and remove filter screen, filter retainer and filter spring by pushing the retainer back against the spring. See Figure 8-38.

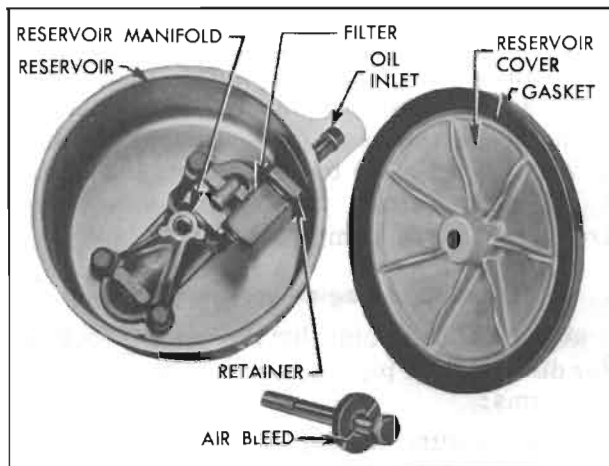

Figure 8-38—Reservoir with Cover Removed

3. Then remove pump manifold, housing, and gaskets. See Figure 8-39. Mark pump body and rotor ring for correct assembly.

4. Remove four bolts (no lockwashers) and carefully separate the pump cover from rotor ring and body using care not to lose the control

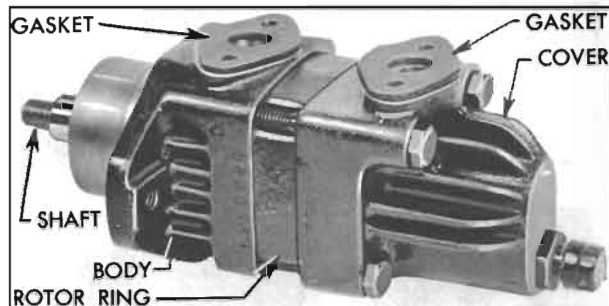

Figure 8-39—Pump with Reservoir Removed

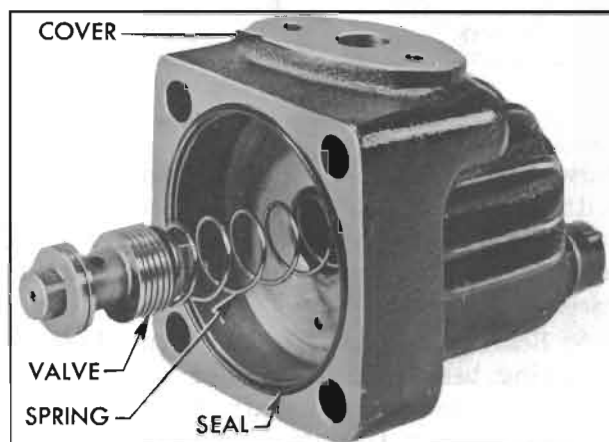

Figure 8-40—Pump Cover and Control Valve

valve which is under spring pressure. Then remove the control valve assembly and spring from pump cover. See Figure 8-40.

5. Mark position of pressure plate and remove plate from dowel pins extending through the rotor ring, then remove rotor ring, O-ring seal, rotor, vanes and dowels. See Figure 8-41.

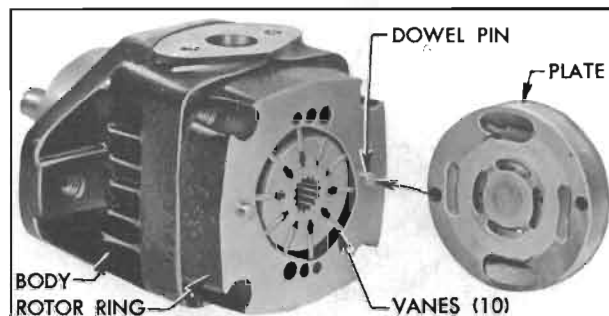

Figure 8-41—Pressure Plate, Ring, Rotor and Vanes

6. Remove pump shaft seal by prying from front with sharp screw driver or awl, being careful not to damage shaft or seal bore. Discard seal.

7. Using No. 3 Truarc pliers J 4245 remove bearing front retaining ring, then push shaft

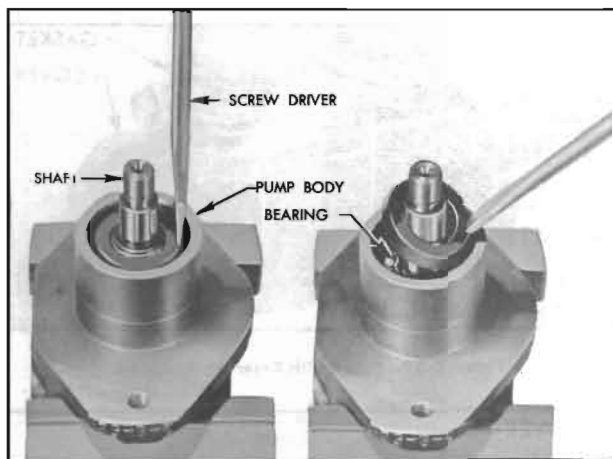

Figure 8-42—Removing Shaft Oil Seal

forward to remove shaft and bearing, rapping with soft hammer. If more than moderate rapping is necessary to remove shaft and bearing assembly, the bearing must be replaced as the races will be brinelled.

8. Bearing may be removed from shaft by removing bearing rear retainer and pressing toward splined end of shaft. Press on inner race of bearing. If sintered bushing in pump body is worn, replace body. If shaft is worn or damaged, replace shaft and bearing assembly.

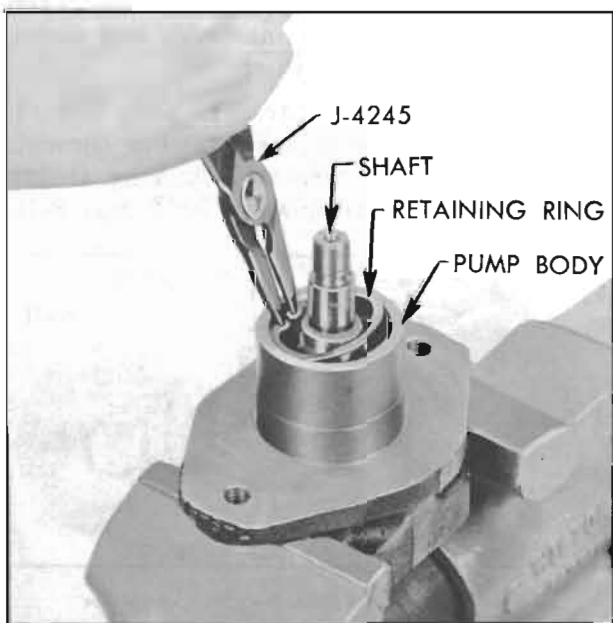

Figure 8-43—Removing Bearing Retaining Ring

b. Inspection of Saginaw Pump Parts

1. Wipe the bearing and shaft assembly with clean cloths; do not soak in cleaning solvent as the lubricant sealed into the bearing

may be diluted by solvent. Wipe dry with clean lint-free cloths.

2. Inspect the drive shaft for wear and check the ball bearing for roughness or noisy operation. If the ball bearing must be replaced, press the new bearing on shaft with a tool that applies pressure on the inner race only.

3. Check fit of vanes in slots of rotor; vanes must slide freely but fit snugly in slots. Tightness may be relieved by thorough cleaning or removal of irregularities using Arkansas stone. Replace rotor if excessive looseness exists between rotor and vanes, and replace vanes if they are irregularly worn or scored.

4. Inspect all ground surfaces of the rotor ring for roughness or irregular wear. Slight irregularities may be removed with a hard Arkansas stone. Replace ring if inside cam surface is scored or worn.

5. Inspect the flat faces of the pressure plate and body for wear or scoring. These faces may be repaired by lapping until smooth and flat, after which all lapping compounds must be thoroughly washed away.

6. Inspect the control valve bore in pump cover for scores or other damage. Hair line scratches are normal but heavy scratches or scores should be cleaned up with a cylindrical hard Arkansas stone. If this cannot be done satisfactorily, replace the cover.

7. Inspect ground surfaces of the control valve for scores. Hair line scratches are normal but heavy scratches or scores should be cleaned up with a hard Arkansas stone. Replace the valve assembly if it is a badly scored or if it is found to be the cause of low pump pressure. It is not practicable to disassemble the control valve. Make certain that control valve slides freely in bore of pump cover.

c. Assembly of Saginaw Pump

Assemble the pump by reversing procedure for disassembly, paying attention to the following items:

1. Make sure that all parts are absolutely clean, and lubricate all moving parts with clean Dynaflo oil during assembly.

2. Use new seals and gaskets.

3. Make certain the bearing and shaft seal are firmly seated in their proper positions. The shaft seal must be installed with the word "outside" toward the front of the pump. Immerse the seal in Dynaflo Oil before installa-

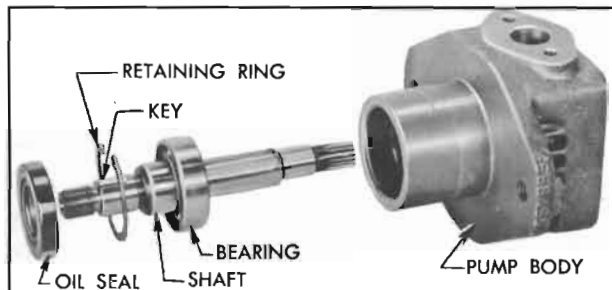

Figure 8-44—Shaft, Bearing and Seal Assembly

tion. Using Installer J-6539 drive seal into body. See Figure 8-44.

4. Install the outer bearing retaining ring with the *beveled side outward*.

5. The rotor ring must be installed over the dowel pins with the embossed arrow pointing in a *counterclockwise* direction as viewed from *rear end* of pump.

NOTE: *When viewed from the front or shaft end of pump, the arrow on the ring points in a clockwise direction, which is the direction of rotation of pump shaft.*

6. Install vanes in slots of rotor with the rounded edge outward toward the ring. The rotor is installed with the chamfered end of its splines toward the front.

7. When pump cover is installed turn bolts down to 25 to 30 foot pounds torque. Install

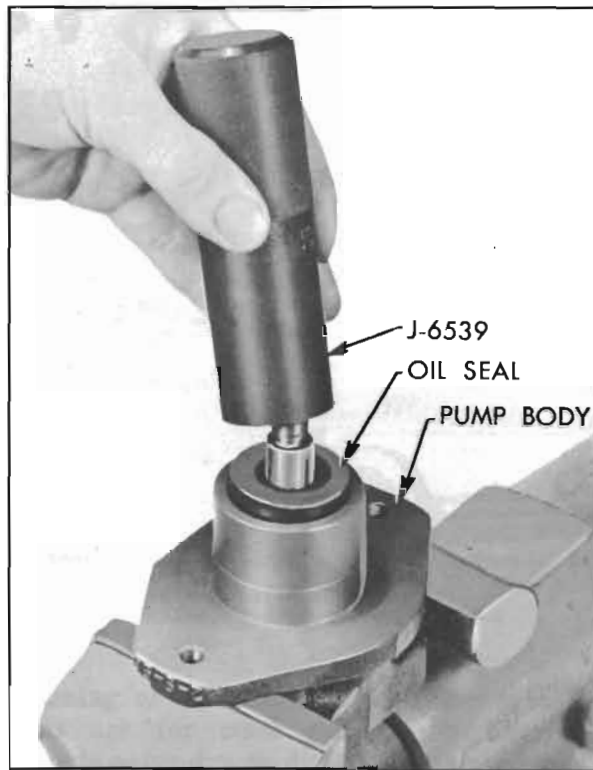
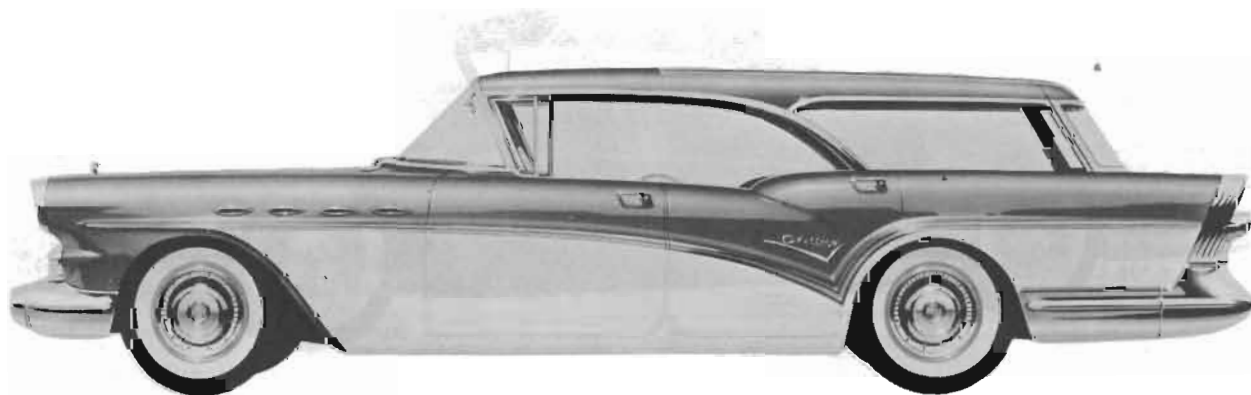
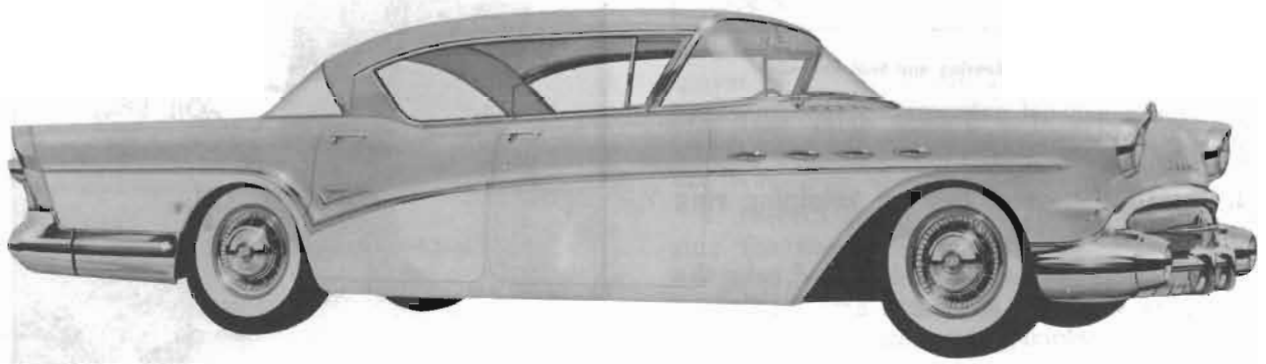

Figure 8-45—Installing Drive Shaft Seal

reservoir with new gaskets, then tighten to 8 to 10 ft. lbs. torque. Install filter spring, filter retainer, and filter.

8. When assembly is completed, rotate pump shaft to insure free movement.





Model 53

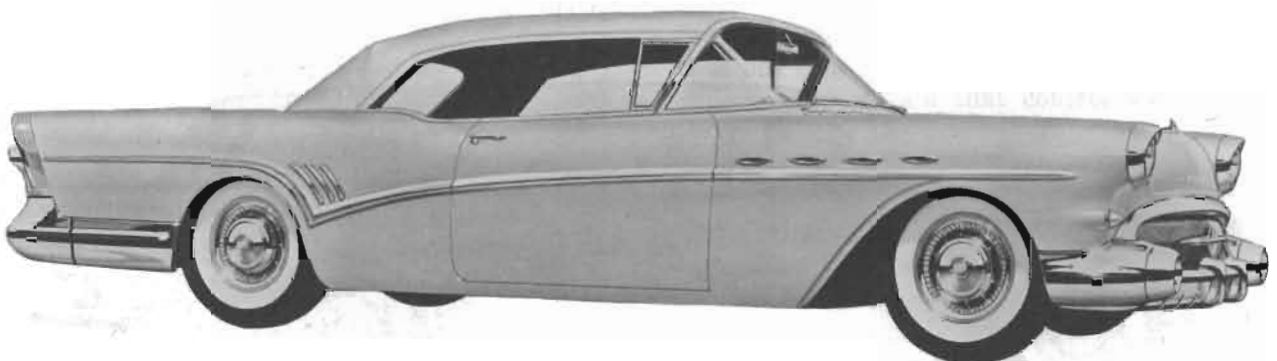

Model 56C