

## SECTION 10-D

### GENERATING SYSTEM

#### CONTENTS OF SECTION 10-D

Paragraph	Subject	Page	Paragraph	Subject	Page
10-20	The Generating System.....	10-19	10-25	Generator Repairs—On Bench	10-25
10-21	Description of Generator.....	10-19	10-26	Test and Minor Adjustment of Generator Regulator— On Car.....	10-27
10-22	Description of Generator Regulator.....	10-19	10-27	Generator Regulator Repairs— On Bench.....	10-30
10-23	Periodic Inspection and Test of Generator—On Car.....	10-23			
10-24	Bench Test of Generator.....	10-25			

### 10-20 THE GENERATING SYSTEM

The generating system restores to the battery the energy used in cranking the engine. It also supplies current to carry the electrical load of the ignition, lights, signalling devices, and accessories, at operating speeds above 25 MPH up to the limit of the generator's capacity. At speeds below 25 MPH the output of generator is not sufficient to carry the electrical load of all units, therefore the battery supplies the additional current required.

The generating system consists of the generator (par. 10-21), generator regulator (par. 10-22), charge indicator, battery (par. 10-14), the wires and cables connecting these units, and the battery ground cable and ground through engine crankcase which completes the circuit. See figure 10-6.

The charge indicator indicates charging current going into the battery and the current leaving battery, except when cranking the engine. The charge indicator does not indicate total charging rate of generator since current supplied by generator to electrical units other than the battery does not pass through the indicator.

### 10-21 DESCRIPTION OF GENERATOR

The generator is a two-brush, two-pole shunt wound unit which is capable of delivering 35 amperes at 14 volts when hot. No special generator is used on cars having air conditioners.

The maximum output of generator is controlled by the current regulator; however, the generator does not normally deliver the maximum output because the voltage regulator controls output in accordance with the requirements of the battery and the current consuming units in operation. See figure 10-6.

The generator pulley drives a fan which draws a draft of air through the generator to

carry away the heat produced during operation. This ventilation permits the generator output to be increased to higher values than would be possible in a non-ventilated generator of the same size.

The armature shaft is supported by an annular ball bearing in the drive end frame and a bronze bushing in the commutator end frame. Both ends are provided with oil cups for periodic application of engine oil.

The two brushes are mounted in individual brush holders attached to the field frame and are held in contact with the commutator by spring loaded brush arms. One brush holder is grounded to the frame by the attaching rivet. The opposite brush holder is attached to the frame by a rivet and the "A" terminal screw but is completely insulated from the frame. The brush in this holder is connected to the field coils and to the "A" terminal screw. See figure 10-12. Each field coil is held in place by a pole shoe attached to the frame by a large screw, and the coil is separated from its pole shoe by heavy insulation. See figure 10-7.

The generator is mounted on a bracket on right side of engine and is driven by the fan belt. The method of mounting permits generator to be moved in or out to adjust tension of fan belt.

### 10-22 DESCRIPTION OF GENERATOR REGULATOR

The generator regulator is mounted on the left rear fender skirt and is cushioned by rubber to dampen the noise which is caused when the regulators operate. The regulator is grounded to the fender skirt through two of the attaching bolts, and to insure positive ground the base of regulator is also connected by a wire to the generator frame.

The generator regulator contains a cutout relay, current regulator, and voltage regulator, all mounted on one base and enclosed by a

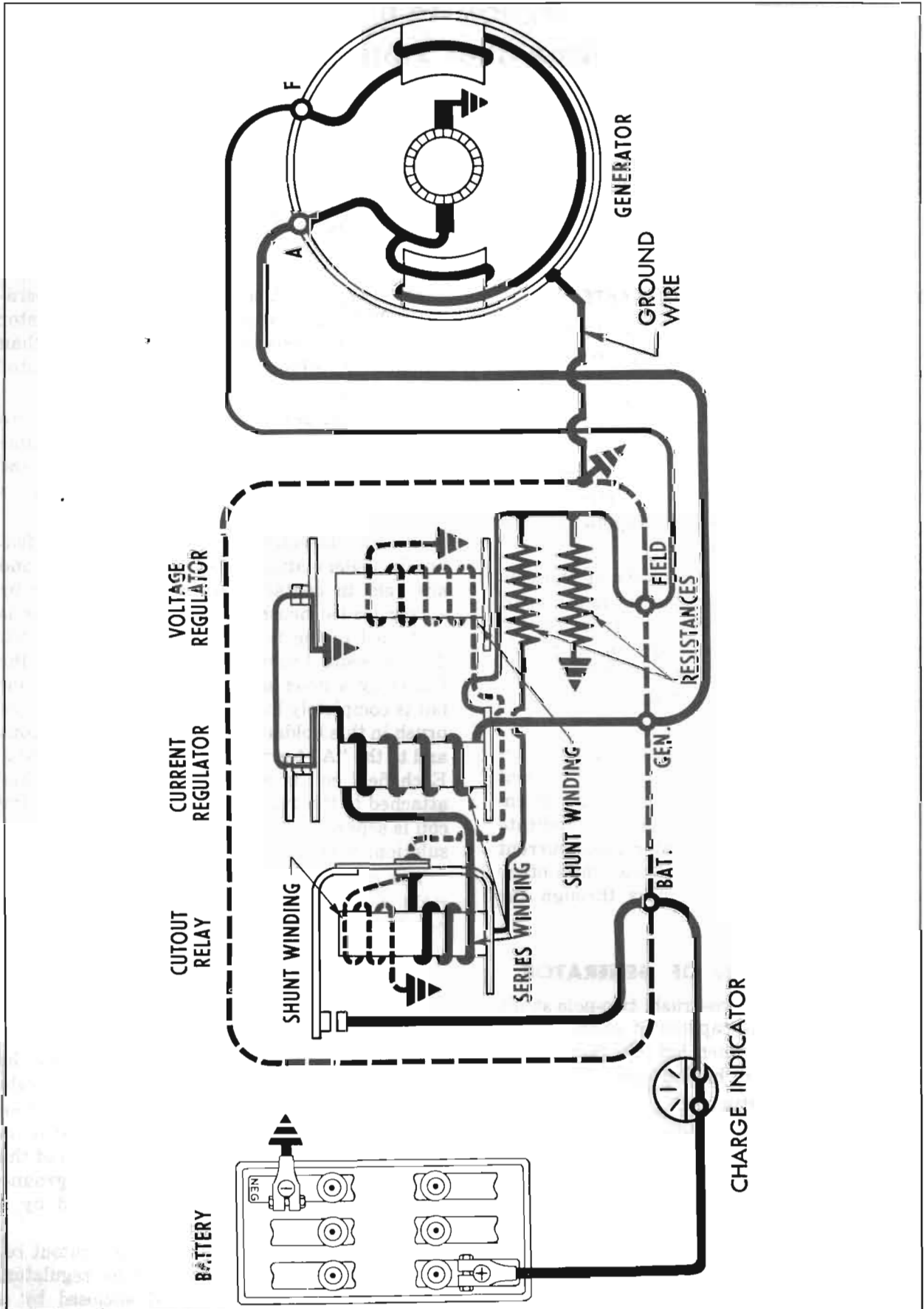

Figure 10-6—Generator System Circuits

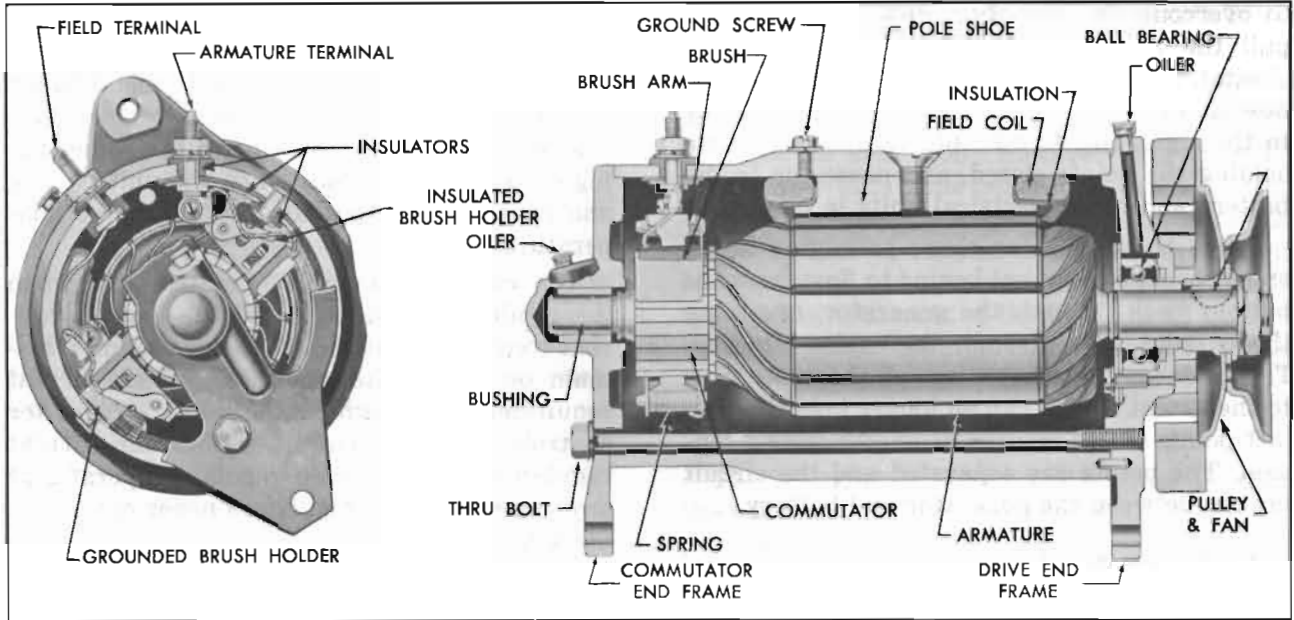

Figure 10-7—Generator, Sectional View

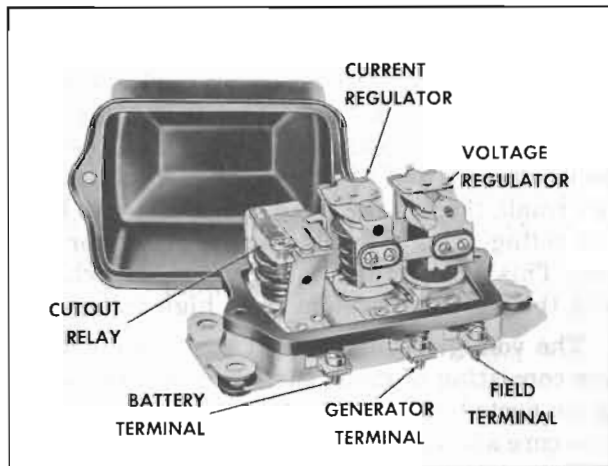

Figure 10-8—Generator Regulator

sheet metal cover. See figure 10-8. These three devices are magnetic switches whose functions and operations are as follows:

**a. Cutout Relay**

The cutout relay opens the circuit to prevent the battery from discharging to ground through the generator whenever the engine is stopped or generator is operating at such low speed that its voltage is less than voltage of battery. When the voltage of generator is slightly greater than battery voltage the relay closes the circuit so that generator can furnish current to the electrical system.

The cutout relay has a series or current winding of a few turns of heavy wire, and a

shunt or voltage winding of many turns of fine wire, both assembled on the same core. The shunt winding is connected between generator armature and ground so that generator voltage is impressed upon it at all times. The series winding is connected so that all generator output current must pass through it. It is connected to a flat steel armature which has a pair of contact points through which current passes to the battery and other electrical units. The contact points are held open by armature spring tension when the unit is not operating. See figure 10-9.

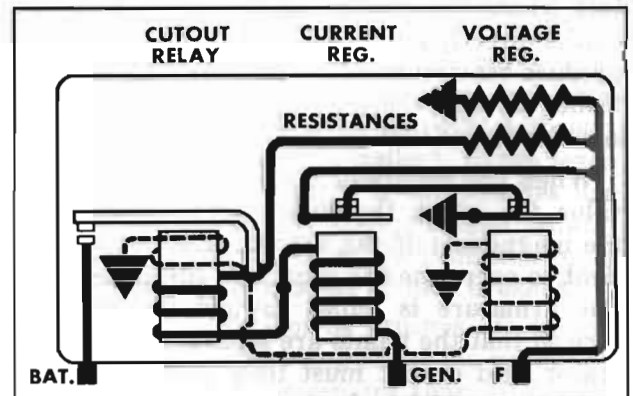

Figure 10-9—Generator Regulator Circuits

When the generator begins to operate, voltage builds up and forces current through the shunt winding, thereby magnetizing the core. When the voltage reaches the value for which the relay is set, the magnetism is strong enough

to overcome the armature spring tension and pull the armature toward the core, thereby closing the contact points. Generator current now flows through the series winding of relay in the right direction to add to the magnetism holding the points closed, and passes on to the battery and other electrical units in operation.

When the generator slows to engine idling speed, or stops, current begins to flow from the battery back through the generator, reversing the current flow through the series winding. This reduces the magnetism of the relay core to the extent that it can no longer hold the contact points closed against armature spring tension. The points are separated and the circuit broken between the generator and battery.

#### **b. Current Regulator**

The current regulator automatically controls the maximum output of the generator. When the current requirements of the electrical system are large and the battery is low, the current regulator operates to protect the generator from overload by limiting its output to a safe value.

The current regulator has one series winding of heavy wire through which the entire generator output flows at all times. This winding connects to the series winding in the cutout relay, described above. Above the winding core is an armature, with a pair of contact points which are held together by spring tension when the current regulator is not operating. When current regulator is not operating and the contact points are closed, the generator field circuit is directly grounded so that generator may produce maximum output, unless further controlled by the voltage regulator described below. See figure 10-9.

When the generator output increases to the value for which the current regulator is set, the magnetism of the current winding is sufficient to overcome the armature spring tension. The armature is pulled toward the winding core so that the points are separated. The generator field circuit must then pass through a resistance, which reduces the flow through the field coils and thereby reduces the output of generator. This reduces the magnetic strength of the current winding so that spring tension again closes the contact points, directly grounding the generator field circuit and increasing generator output. This cycle is repeated many times a second, and the action limits the gen-

erator output to the value for which the regulator is set.

The current regulator has a bi-metal hinge on the armature for thermostatic temperature control. This automatically permits a somewhat higher generator output when the unit is cold, and causes the output to drop off as the temperature increases.

The current regulator operates only when the condition of battery and the load of current-consuming units in operation require maximum output of the generator. When current requirements are small, the voltage regulator controls generator output. Either the current regulator or the voltage regulator operates at any one time; both regulators never operate at the same time.

#### **c. Voltage Regulator**

The voltage regulator limits the voltage in the charging circuits to a safe value, thereby controlling the charging rate of the generator in accordance with the requirements of the battery and the current-consuming electrical units in operation. When the battery is low, the generator output is near maximum but as the battery comes up to charge, and other requirements are small, the voltage regulator operates to limit the voltage, thereby reducing the generator output. This protects the battery from overcharge and the electrical system from high voltage.

The voltage regulator unit has a shunt winding consisting of many turns of fine wire which is connected across the generator. The winding and core are assembled into a frame. A flat steel armature is attached to the frame by a flexible hinge so that it is just above the end of the core. The armature contains a contact point which is just beneath a stationary contact point. When the voltage regulator unit is not operating, the tension of a spiral spring holds the armature away from the core so that the points are in contact and the generator field circuit is completed to ground through them. See figure 10-9.

When the generator voltage reaches the value for which voltage regulator is set, the magnetic pull of the voltage winding is sufficient to overcome the armature spring tension, so that the armature is pulled toward the core and the contact points are separated. The instant the points separate, the field current flows to ground through the resistance. This reduces the current flow through the field coils and decreases generator voltage and output.

The reduced voltage in the circuit causes a weakening of the magnetic field of the voltage winding in the regulator. The resulting loss of magnetism permits the springs to pull the armature away from the core and close the contact points again, thereby directly grounding the generator field so that generator voltage and output increases.

This cycle is repeated many times a second, causing a vibrating action of the armature, and holds the generator voltage to a constant value. By maintaining a constant voltage, the voltage regulator continues to reduce the generator output as the battery comes up to charge. When the battery reaches a fully charged condition, the voltage regulator will have reduced the generator output to a relatively few amperes.

The voltage regulator has a bi-metal armature hinge for thermostatic temperature control. This automatically permits regulation to a higher voltage when the unit is cold, and a lower voltage when hot, because a high voltage is required to charge a cold battery.

As previously stated, the current and voltage regulators do not operate at the same time. When current requirements are large, the generator voltage is too low to cause voltage regulator to operate, therefore the current regulator operates to limit maximum output of generator. When current requirements are small, the generator voltage is increased to the value which causes voltage regulator to operate. The generator output is then reduced below the value required to operate the current regulator, consequently all control is then dependent on the operation of voltage regulator.

#### d. Resistances

The current and voltage regulator circuits use a common resistance which is inserted in the field circuit when either regulator operates.

A second resistance is connected between the regulator field terminal and the relay base, which places it in parallel with the generator field coils. The sudden reduction in field current occurring when either the current or voltage regulator contact points open, is accomplished by a surge of induced voltage in the field coils as the strength of the magnetic fields change. These surges are partially dissipated by the two resistances, thus preventing excessive arcing at the contact points.

## 10-23 PERIODIC INSPECTION AND TEST OF GENERATOR—ON CAR

As a general rule, the generator should be inspected and tested every 5000 miles to determine its condition; however, the type of service in which some generators are used may make more frequent inspection advisable. High speed operation, excessive dust or dirt, high temperatures and operation of generator at or near full output most of the time are all factors which increase bearing, commutator and brush wear.

### a. Inspection of Generator

The following inspection will disclose whether the generator is in proper condition for service or in need of removal for repairs.

1. Using a good light and a mirror, inspect the commutator through the openings in the commutator end frame. Low or unsteady output may result if the commutator is coated with grease or dirt, or is rough, out of round, or has high mica between the bars. If commutator bars are burned an open circuit is indicated.

2. Inspect commutator end of generator for thrown solder, indicating that generator has been overheated due to excessive output.

Excessive output usually results when the generator field is grounded, either internally or at the regulator. If this is indicated, disconnect the wire at "F" terminal of generator or regulator and run engine at medium speed. If generator output drops off the regulator is at fault but if output remains high the field is grounded internally in generator.

3. Check condition of brushes; make sure they are not binding in holders and that they are resting on the commutator with sufficient tension to give good, firm contact. Brush leads and screws must be tight. If the brushes are worn down to one-half their original length, compared with new brushes, the generator must be removed for installation of new brushes.

4. If the commutator or brushes are in bad condition, other than being dirty, the generator should be removed for repairs (par. 10-25). If these parts are only dirty, however, they may be cleaned without removal of generator.

Clean off any grease with a cloth soaked with carbon tetrachloride or other non-inflammable solvent. While engine is running, polish commutator with a brush seating stone or with a strip of 2/0 sandpaper placed over a smooth piece of

thin wood. *Never use emery cloth on the commutator because it will cause arcing, burning, and rapid wear of the brushes. After cleaning commutator blow out all dust from generator.*

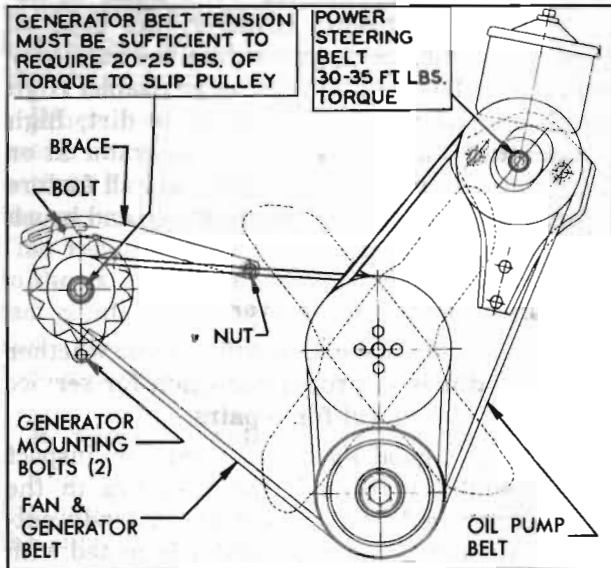

Figure 10-10—Generator Belt Adjustment

5. Check fan belt for condition and proper tension (fig. 10-10), and make certain that all generator mounting bracket and brace bolts are tight. A loose fan belt will permit belt slippage, resulting in rapid belt wear and low or erratic generator output. An excessively tight belt will cause rapid belt wear and rapid wear of generator and water pump bearings. **NOTE:** *If belt requires adjustment, first loosen belt so that generator pulley is free, then check pulley for tightness and check generator bearings for freeness of rotation and excessive side play. Tight or excessively worn bearings should be cleaned or replaced.*

6. Inspect and manually check all wiring connections at generator, regulator, charge indicator, junction block and battery to make certain that connections are clean and tight. Clean any loose connections before tightening, to insure good contact. Inspect wiring for broken insulation, broken strands, and loose terminals. Make any corrections necessary to eliminate excessive resistance.

#### b. Testing Generator Output

After the inspection given above it is advisable to test the generator for output. *Before making the following tests make certain that battery specific gravity is not less than 1.215.*

1. Disconnect wire from generator regulator

terminal marked "BAT" and connect an ammeter in series with this terminal and the disconnected wire.

2. Connect jumper wire between regulator terminal marked "F" and base plate of regulator so that current and voltage regulators cannot operate to control generator output.

3. Start engine and with all electrical units turned off slowly increase engine speed until ammeter registers 35 amperes, which should be reached at approximately 1100 RPM of engine when generator is HOT, or at slightly lower speed when generator is cold. **CAUTION:** *Do not exceed 1300 RPM of engine while "F" terminal is grounded.*

4. If 35 amperes cannot be obtained at approximately 1100 RPM of engine check fan belt for proper tension (fig. 10-10). If fan belt is not slipping the generator does not have proper output. Remove generator for bench test (par. 10-24) and make necessary corrections before attempting any adjustment of generator regulator.

5. Leave ammeter and field jumper wire in place for the charging circuit test (subpar. c).

#### c. Testing Charging Circuit Wiring

Excessive voltage drop in the charging circuit (resulting from loose connections or other high resistance) tends to keep the battery in an undercharged condition. To check voltage drop, proceed as follows:

1. Make sure that all accessories are turned off and that ammeter and field jumper lead are in place. See Figure 10-11.

2. Start engine and slowly increase speed until ammeter reads 20 amperes. **CAUTION:** *Do not run engine faster than necessary or generator may be damaged.*

3. Measure the voltage drop at V-1, V-2 and V-3. See Figure 10-11. Readings V-1 and V-3 should not exceed .4 volt each. Reading V-2 should not exceed .1 volt.

4. If any voltage reading exceeds these limits, excessive resistance is indicated in that part of the charging circuit. To correct, clean and tighten connections; if this fails to reduce voltage drop, replace faulty wire.

5. Remove voltmeter. Remove ammeter and reconnect lead to "BAT." terminal of regulator. **CAUTION:** *Be sure field jumper lead is removed.*

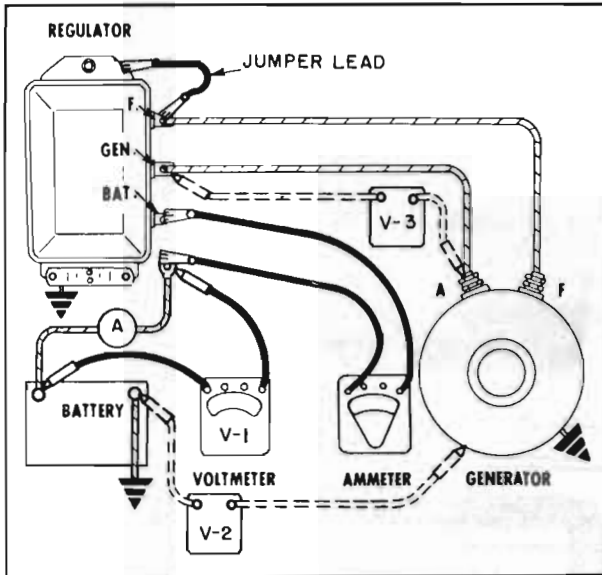

Figure 10-11—Testing Charging Circuit Voltage Drop

## 10-24 BENCH TEST OF GENERATOR

The following inspection and test of generator, after removal from car, may be used to determine the cause of unsatisfactory output before generator is disassembled.

1. Inspect condition of brushes and commutator as described in paragraph 10-23. If brushes and commutator are in satisfactory condition and the cause of trouble is not apparent proceed to the following steps.

2. Place piece of cardboard between commutator and grounded brush. Using test lamp and points, check for grounds with test points on "A" terminal and generator frame. If lamp lights, the generator is internally grounded. Locate the ground by insulating the other brush also, and checking the brush holders, armature, commutator and field separately.

3. If generator is not grounded, check the field for open circuits by placing one test lamp point on the "F" terminal and the other point on the insulated brush holder to which the other end of field coil is connected. If lamp does not light the field has open circuit. If the open circuit is due to a broken lead or bad connections, it can be repaired but if the open circuit is inside one of the field coils the coil must be replaced.

4. If the field is not open, check for a short circuit by connecting a 12-volt battery and an ammeter in series with the field coils. Proceed with care since a shorted field may draw excessive current which might damage the ammeter. An ammeter reading of 1.69 to 1.79 amperes in-

dicates field is satisfactory; a higher reading indicates a short circuit.

5. If the cause of trouble has not been located, disassemble generator for test of armature (par. 10-25).

6. If a shorted field is found be sure to check for burned contact points in the generator regulator (par. 10-26) because a shorted field may permit an excessive field current which could burn the contact points.

7. When testing generator on a generator and regulator tester, generator must be able to put out 35 amperes (hot) at 14 volts when generator speed is 2600 RPM.

## 10-25 GENERATOR REPAIRS—ON BENCH

### a. Disassembly, Cleaning and Inspection

When it is necessary to disassemble generator for any reason, make a complete clean up and test to make sure all parts are in satisfactory condition. See figure 10-12 for identification of generator parts.

1. Unscrew both through bolts and remove the commutator end frame from the field frame.

2. Disconnect brush leads and remove brushes from holders, then remove armature, drive end frame and pulley assembly from the field frame.

3. Hold armature in vise equipped with soft jaws, and avoid excessive tightening of vise. Remove pulley nut, lock washer, pulley, fan, key, collar, and drive end frame from armature shaft. Remove spacer washer.

4. Remove bearing retainer plate, gasket, bearing, plate and felt washer from drive end frame.

5. Thoroughly clean and inspect the ball bearing, and if satisfactory for use, pack it with high melting point ball bearing grease. Replace worn or rough bearing.

6. Clean all other parts by wiping with clean cloths. The armature and field coils must not be cleaned in any degreasing compound since this might damage insulation so that a short or ground would subsequently develop.

7. Carefully inspect all parts for wear or damage and make necessary repairs, or replace unserviceable parts. Any soldering must be done with rosin flux; never use acid flux on electrical connections. If brush springs are distorted or show evidence of overheating, replace them.

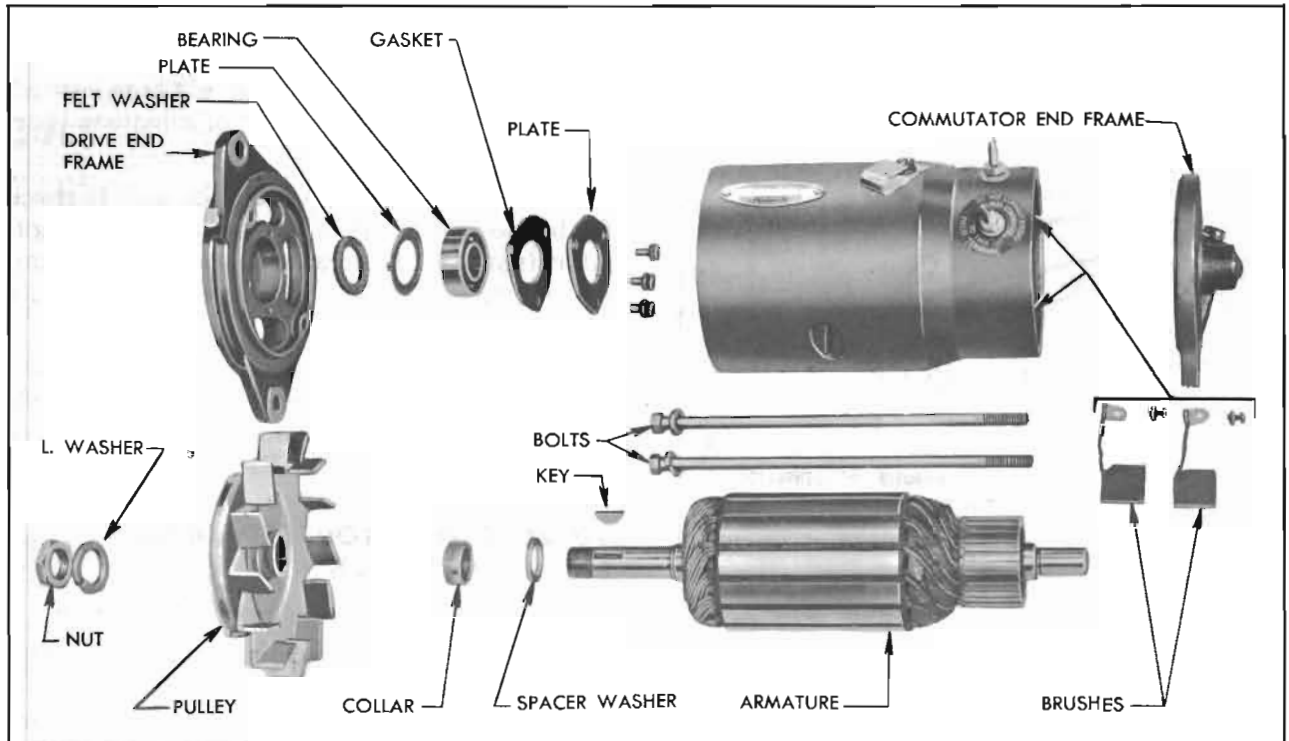

Figure 10-12—Generator Disassembled

### b. Testing and Repairing Armature

Before making any repairs to the armature, test it for open, shorted or grounded circuits.

Open circuits in armature are usually obvious since the open circuited commutator bars are usually burned as a result of arcing as they pass under the brushes. If generator has overheated and thrown solder, the open circuit will be at connections to commutator riser bars. Repair can be affected by resoldering leads to riser bars, using rosin flux.

Test for grounds, using test lamp and points, by placing one test point on armature core and the other test point on commutator. If lamp lights, the armature is grounded. If grounds are at points where coils come out of slots in core, repairs can be made by placing insulating strips between core and coil which is grounded.

Check armature for short circuits by placing it on a growler and slowly turning armature while holding a thin strip of steel (hacksaw blade) above armature core. The steel strip will vibrate when above the area of armature core in which any short circuited coils are located. Copper or brush dust in slots between commutator bars may cause shorts between bars which can be eliminated by cleaning out the slots. Shorts at cross-over of coils at the drive end can

often be corrected by bending the wires slightly and reinsulating the exposed bare wire.

If armature is otherwise satisfactory but commutator is worn, burned, out of round, or has high mica between bars, the commutator should be turned true in a lathe. After turning, undercut mica  $\frac{1}{32}$ " , then carefully clean all dirt and copper dust out of slots. Lightly polish the commutator with 2/0 sandpaper to remove all slight burrs left by undercutting operation.

### c. Replacement of Brush Holders

When it is necessary to replace a brush holder, drill out the attaching rivet with a No. 2 drill to remove old holder from the field frame. Attach the new brush holder with the screw, lock-washer, and nut provided in the brush holder service package.

When installing the insulated brush holder place insulating bushing on attaching screw with flat side against screw head. Locate screw and bushing in hole of brush holder, force flat-sided hole of insulating strip over screw threads, install parts in field frame and install lock-washer and nut on screw finger tight. Thread the terminal stud through slot in brush holder and round hole in insulating strip, then install insulating bushing, flat washer, lockwasher, and nut. Tighten attaching screw and stud nuts



securely. Attach field coil and brush leads to inner end of terminal stud.

#### d. Assembly and Installation of Generator

Assemble generator by reversing the disassembly procedure, paying attention to the following points:

1. If field coils were removed from the field frame be sure that insulation is placed between the coils and the pole shoes. Use care in tightening pole shoe screws to avoid distortion of parts, and make sure that screws are securely tightened.

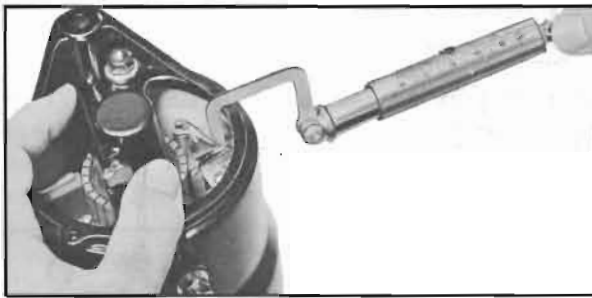

Figure 10-13—Checking Brush Spring Tension

2. After the commutator end frame is installed to support the armature check the tension of both brush springs, using Brush Tension Checking Scale J 5184. See figure 10-13.

When using the scale, apply a steady pull *at 90 degrees to brush arm* and note the scale reading at instant that brush arm is lifted off the brush. The reading should be between 26 and 32 ounces. If tension is not within these limits replace springs.

3. New brushes must be seated to make good contact with armature, using a brush seating stone. This is a soft abrasive material which, when held against a revolving commutator, disintegrates so that particles are carried under the brushes and wear their contacting faces to the contour of the commutator in a few seconds. This operation may be performed on the bench if means are available for turning the armature, or it may be performed after generator is installed on engine. Blow all dust out of generator after the brushes are seated.

4. Connect the white armature wire to the "A" terminal of generator. This is the *right hand* terminal, farthest from engine. Connect the pink field wire to the left hand terminal.

**CAUTION:** Connect radio condenser to armature output "A" terminal.

5. Before the engine is started, momentarily bridge between the "BAT" and "GEN" terminals of the generator regulator with a jumper wire or screwdriver. This allows a momentary surge of current from battery to generator, which correctly polarizes the generator with respect to the battery. Adjust fan belt as shown in figure 10-10.

## 10-26 TEST AND MINOR ADJUSTMENT OF GENERATOR REGULATOR—ON CAR

### a. Preliminary Instructions

The generator regulator should be tested when difficulty is experienced in keeping the battery charged, or when battery uses an excessive amount of water, which is usually caused by a high charging rate. Before testing the generator regulator make certain that the generator and circuit wiring are in good condition by performing the inspection and test given in paragraph 10-23.

The "Fixed Resistance" method of testing the operation and calibration of the generator regulator is recommended in preference to the "Variable Resistance" method which employs a variable resistance connected in series between the generator regulator and the car battery. The "Fixed Resistance" method uses a calibrated fixed resistance ( $\frac{1}{4}$  ohm, approximately 25 watts) in series between generator regulator and car battery. All tests can be made without removing regulator cover, therefore proper regulator temperature can be maintained during tests.

The procedure given below in subparagraph d provides a "Fixed Resistance" method of testing the generator regulator. **CAUTION:** *Never under any circumstances attempt to adjust generator regulator without first hooking-up an approved test instrument. Serious damage to generator, battery, or other electrical units might result if regulator were improperly adjusted.*

After any test or replacement of regulator, the car generator must be polarized after all wires are connected but *before engine is started*. Failure to polarize generator may result in severe damage to the equipment since reversed polarity causes vibration, arcing and burning of the relay contact points. The generator may be readily polarized by momentarily bridging between the "BAT" and "GEN"

terminals of regulator to cause a surge of current through the generator.

Always make certain that rubber gasket is in proper position to seal regulator cover when installed. The gasket prevents entrance of dust, moisture, and oil vapors which might damage the regulator.

**IMPORTANT:** Mechanical checks and adjustments, such as air gap and point opening, must be made with battery disconnected from regulator and preferably with regulator removed from car.

#### b. Calibration of Test Voltmeter

The calibration of the test voltmeter should be frequently checked and should always be checked immediately following malhandling, sluggish movement of pointer, or when the meter has been dropped.

If the instrument being used does not have built-in provision for checking the calibration of the voltmeter and no commercial testing laboratory is available, the voltmeter may be calibrated against a specially prepared storage battery as follows:

1. Select a satisfactory new 12-volt automotive storage battery and charge slowly (1 amp. per positive plate) until fully charged. Specific gravity of electrolyte should read between 1.260 and 1.280 in all cells. Allow battery to stand over night at approximately 80°F. for stabilization of voltage. Battery terminal voltage will then be 12.8 volts. **CAUTION:** *Do not use battery for calibration immediately after charging because battery voltage will be abnormally high for several hours.*

2. Check the test voltmeter against prepared battery and note reading. If meter does not read 12.8 volts, calculate the difference. Assume that error will be the same between 14 and 15 volts and allow this difference when using voltmeter to test and adjust generator regulator. If voltmeter is found faulty it should be repaired at first opportunity.

The prepared calibrating battery also may be used to check an open circuit type battery testing meter by measuring the voltage of one cell, which will be 2.13 volts.

#### c. Testing Regulator for Oxidized Points

Abnormal fluctuation of the charge indicator, or of the voltmeter or ammeter pointer while testing the voltage or current regulator indi-

cates an oxidized condition of regulator contact points. This condition may cause a high resistance in the generator field circuit and reduced generator output. Test for oxidized contact points as follows:

1. With engine stopped, disconnect battery lead from regulator terminal marked "BAT." Connect ammeter red lead to "BAT" terminal and ammeter black lead to battery lead.

2. Turn on headlights. Start engine and adjust speed until test ammeter reads exactly 5 amperes.

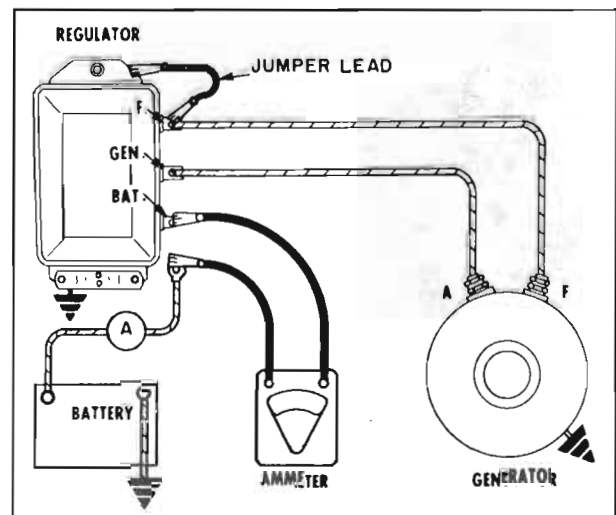

Figure 10-14—Testing Regulator for Oxidized Points

3. Connect jumper lead from regulator "F" terminal to ground on regulator base. See figure 10-14. If ammeter reading increase more than 2 amperes, oxidized contact points are indicated. Regulator should be removed and contact points cleaned before proceeding to any other regulator tests. See paragraph 10-27 for cleaning procedure.

#### d. Test and Adjustment of Generator Regulator

Before testing or adjusting the generator regulator, it is advisable to first test the generator output and the charging circuit wiring as described in paragraph 10-23. If generator output or charging circuit voltage drop are not within specifications, repairs should be made before testing the generator regulator.

The following is the procedure in general for making tests and adjustments of the cutout relay, voltage regulator and current regulator in the order named. For specific instructions,

refer to the pamphlet which was received with your test instrument. NOTE: *Regulator cover must be in place during all tests.*

1. Before using tester, make sure all needles on instrument are properly calibrated according to manufacturers instructions.

2. Connect tachometer from distributor terminal of coil to ground.

3. With engine stopped, disconnect battery lead from regulator terminal marked "BAT." Connect ammeter red lead to "BAT" terminal and ammeter black lead to battery lead. CAUTION: *Never allow one ammeter clip to touch ground while other clip is connected to a source of current or ammeter may be damaged.*

4. Turn voltmeter selector switch to position for 12 volt system. Then connect voltmeter red lead to "GEN" terminal of regulator and voltmeter black lead to ground on base plate of regulator. See figure 10-15.

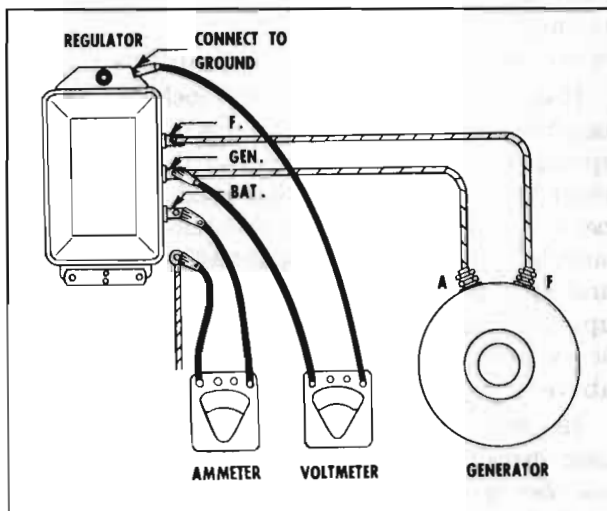

Figure 10-15—Testing Cutout Relay

5. Start engine and warm it up until it is running on slow idle. If cutout relay contacts are closed, reduce engine speed with throttle stop screw until they open, as indicated by ammeter hand returning to zero.

6. Slowly increase engine speed while observing both voltmeter and ammeter. Note highest reading just before ammeter begins to move. This is the closing voltage of the cutout relay, which should be between 11.8 and 13.5.

7. If cutout relay operation is otherwise satisfactory but closing voltage is not between 11.8 and 13.5, remove regulator cover and adjust relay armature spring tension to obtain closing voltage of 12.8. Adjusting screw has a

left hand thread, therefore turning screw clockwise increases spring tension and closing voltage. Turning screw counterclockwise decreases closing voltage. See figure 10-18. *After adjustment, install cover and recheck closing voltage.*

CAUTION: *Never close relay contacts by hand with battery connected to regulator because this will cause a damaging high current arc across contacts.*

8. Shut off engine. Disconnect ammeter, then connect a  $\frac{1}{4}$  ohm resistor (approximately 25 watts) between "BAT" terminal and battery lead. See figure 10-16.

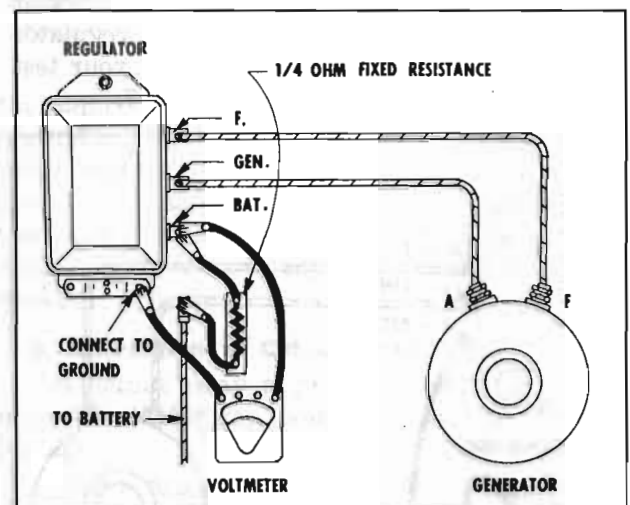

Figure 10-16—Testing Voltage Regulator

9. Change red voltmeter clip from the "GEN" terminal to the "BAT" terminal.

10. Start engine and set fast idle screw on high step of fast idle cam. When engine reaches normal operating temperature, set fast idle screw so that tachometer reads 1500 RPM. NOTE: *This method of setting engine at 1500 RPM will work on all except Stromberg equipped cars.* Run engine at least 15 minutes to permit regulator to reach operating temperature.

CAUTION: *Since the voltage and current regulators are both compensated for temperature, the following tests must be made with regulator at operating temperature to insure accurate results.*

11. When regulator reaches operating temperature, cycle the regulator by gradually reducing engine speed until cutout relay contacts open. Then bring engine speed back to 1500 RPM. Read voltmeter which now indicates the setting of the voltage regulator. This should be between 14 and 15.

12. If voltage regulator operation is otherwise satisfactory, but maximum voltage is not between 14 and 15, remove regulator cover and adjust voltage regulator armature spring tension to obtain a maximum voltage of 14.5. See steps 18 and 19 below for adjusting procedure.

13. Immediately following the voltage regulator test, proceed to the following current regulator test while regulator is still at operating temperature.

14. Shut off engine. Remove  $\frac{1}{4}$  ohm resistor. **CAUTION:** Do not allow disconnected battery lead to touch ground on car.

15. Connect a load from the charging circuit to ground on the base plate of the regulator and connect ammeter as described in your test instrument pamphlet. See figure 10-17.

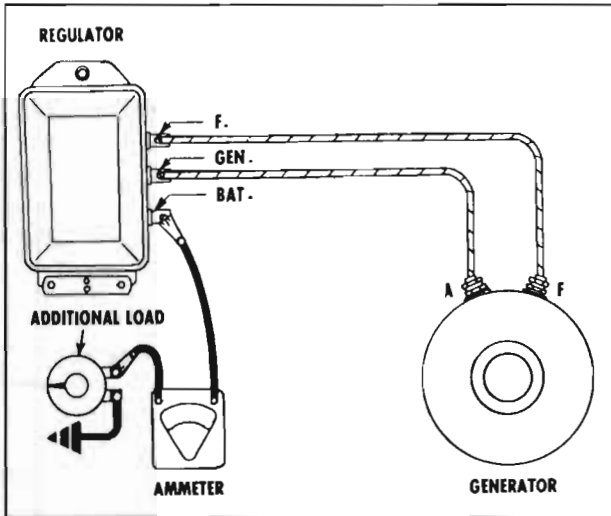

Figure 10-17—Testing Current Regulator

16. Start engine and set speed at 1500 RPM using fast idle cam. Read ammeter which now indicates the setting of the current regulator. This should be between 32 and 38. (If a variable load is used, rotate load control knob for highest possible reading.)

17. If there is abnormal fluctuation of voltmeter or ammeter pointer while testing voltage or current regulator, test for oxidized contact points as described above (par. 10-26, c).

18. If contact points are in satisfactory condition but either the voltage or current regulator did not operate within specified limits, adjust armature spring tension as required. Turn adjusting screw clockwise to increase operating voltage or charging rate. See figure 10-18. *The final setting must always be made by turning screw clockwise to increase voltage*

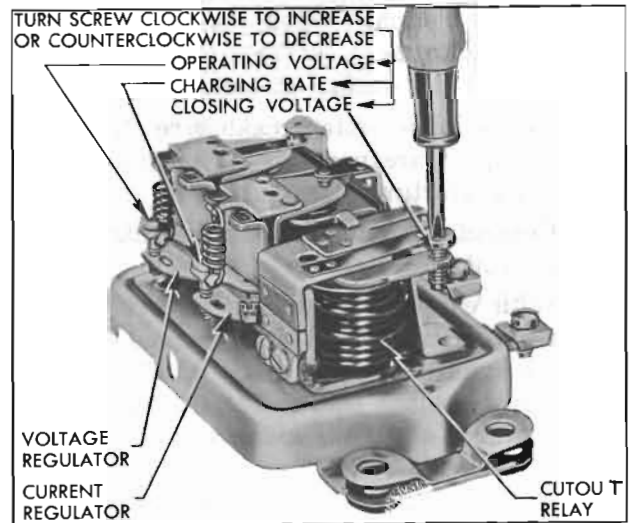

Figure 10-18—Generator Regulator Spring Tension Adjustments

or charging rate—never by turning counterclockwise.

Adjust voltage regulator to obtain operating voltage of 14.5 volts. Adjust current regulator to obtain charging rate of 35 amperes.

If adjusting screw is turned clockwise beyond normal range required for adjustment, the spring support may be bent so that it fails to return when pressure is relieved. If this happens, turn the screw counterclockwise until sufficient clearance exists between screw head and spring support, then bend spring support upward carefully until contact is made with screw head. Make final adjustment as described above.

19. After adjustment of either regulator unit install cover and gasket, *bring regulator up to operating temperature* and recheck setting.

20. Upon completion of all tests and adjustments, disconnect regulator test equipment and reconnect battery wire to "BAT" terminal of regulator. *Before starting engine*, momentarily bridge between the "BAT" and "GEN" terminals with a screwdriver to polarize the generator.

21. Set engine idle speed at 485 RPM, then disconnect tachometer.

## 10-27 GENERATOR REGULATOR REPAIRS—ON BENCH

The contact points of a regulator will become oxidized and pitted after extended service and require cleaning. Contact points also may be burned because of faulty connections in the

charging circuit, shorts or grounds in the generator field circuit, or installation of a radio bypass condenser on the "F" terminal of generator or regulator.

The majority of regulator troubles arise from dirty and oxidized contact points, which cause a reduced generator output. Cleaning of contact points, or replacements if badly burned, followed by adjustment of air gap and spring tension will correct faulty regulator operation in most cases. Cleaning of points and adjustment of regulator should not be attempted with unit on the car; remove regulator so that this work can be done properly.

#### a. Cleaning Regulator Contact Points

Loosen the upper contact support mounting screws on voltage and current regulators and tilt support to one side so that each point can be cleaned separately without danger of bending

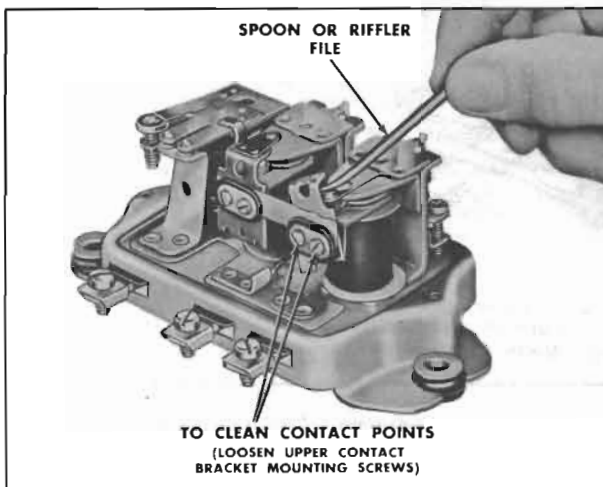

Figure 10-19—Cleaning Voltage Regulator Flat Contact Point

the upper contact spring. Use a thin, fine-cut file on the crowned point on contact support, and use a spoon or riffler file to clean out the cavity which is usually formed in the flat contact point on the armature. See figure 10-19. A flat file will not clean out this cavity. File just enough to remove oxidation. *Never use emery cloth or sandpaper on contact points since particles of emery or sand left on points will cause them to arc and burn.*

After contact supports are returned to position, reset air gaps (subpar. d, below).

#### b. Replacing Upper Contact Supports

If new upper contact supports are required or if supports have been removed, they should be installed as shown in figure 10-20. Note that

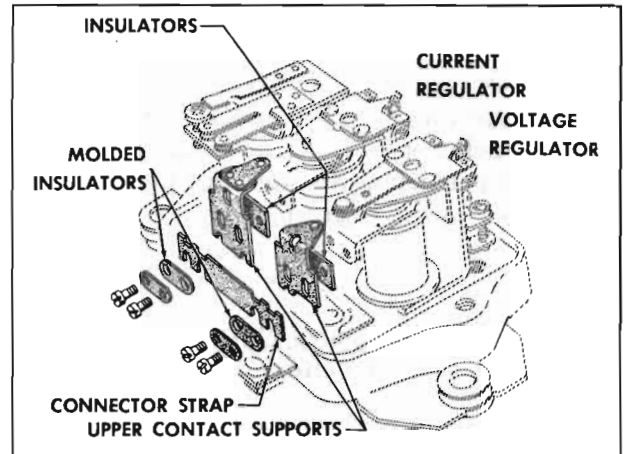

Figure 10-20—Relationship of Connector Strap, Insulators and Upper Contact Supports

the connector strap is *connected* to both voltage regulator and current regulator contact supports, and that the connector strap is *insulated* from all contact mounting screws. Note position of the flat and molded insulators. After installation of contact supports, reset air gaps (subpar. d, below).

#### c. Adjustment of Cutout Relay

The cutout relay requires three checks and adjustment: Air gap, point opening and closing voltage.

1. Place finger on armature directly above core and move armature down until contact points just close. If both sets of points do not close simultaneously, bend spring fingers so that they do. *With points just closed*, measure air gap between armature and center of core; gap should be .020", measured with feeler gauge. Adjust air gap, if necessary, by loosening armature mounting screws and raising or low-

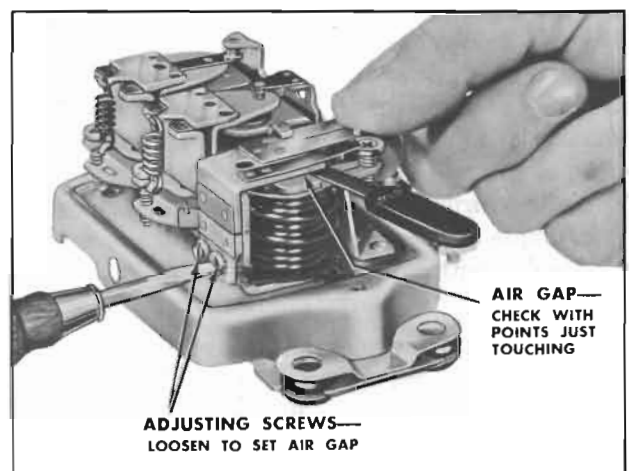

Figure 10-21—Adjustment of Cutout Relay Air Gap

ering armature as required. Tighten screws securely and recheck air gap. See figure 10-21.

2. Check contact point opening with feeler gauges. Opening should be .020". Increase or decrease point opening, if necessary, by bending the upper armature stop. See figure 10-22.

3. Check and adjust closing voltage as described in paragraph 10-24, after installation of regulator on car, or while connected to a proper test generator and battery.

#### d. Adjustment of Voltage or Current Regulator

The voltage and current regulators require

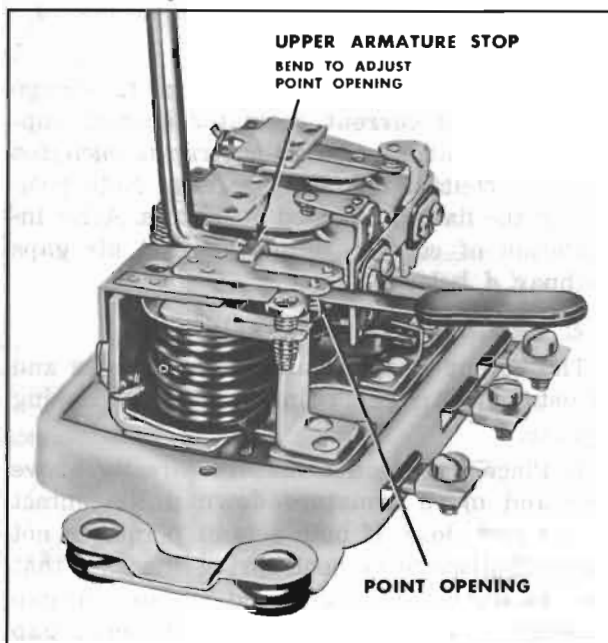

Figure 10-22—Adjustment of Cutout Relay Contact Point Openings

two checks and adjustment; air gap and voltage or current setting.

1. Push armature down to the core and slowly release it *until the contact points just touch*, then measure air gap between armature and center of core, using feeler gauge. Air gap should be .075".

2. Adjust air gap on each unit, if necessary, by loosening contact support mounting screws and raising or lowering support as required. Be sure points are lined up when tightening screws, then recheck gap after adjustment. See figure 10-23.

3. Check and adjust voltage and current settings as described in paragraph 10-24, after installation of regulator on car, or while connected to a proper test generator and battery.

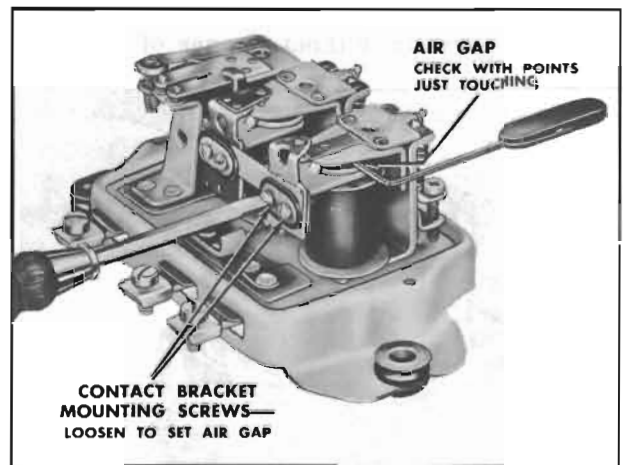

Figure 10-23—Adjustment of Voltage Regulator Air Gap