

# GROUP 5 REAR AXLE ASSEMBLY

## SECTIONS IN GROUP 5

Section	Subject	Page	Section	Subject	Page
5-A	Rear Axle Specifications and Description	5-1	5-C	Removal and Disassembly Procedures	5-9
5-B	Trouble Diagnosis—Rear Axle	5-5			

## SECTION 5-A REAR AXLE SPECIFICATIONS AND DESCRIPTION

### CONTENTS OF SECTION 5-A

Paragraph	Subject	Page	Paragraph	Subject	Page
5-1	Rear Axle Specifications	5-1	5-2	Description of Rear Axle	5-4

### SERVICE BULLETIN REFERENCE

Bulletin No.	Page No.	SUBJECT

### 5-1 REAR AXLE SPECIFICATIONS

#### a. Tightening Specifications

Use a reliable torque wrench to tighten the parts listed, to insure proper tightness without

straining or distorting parts. These specifications are for *clean and lightly lubricated threads only*; dry or dirty threads produce increased friction which prevents accurate measurement of tightness.

Part	Location	Thread Size	Torque—Ft. Lbs.
Nut	Pinion Bearing Lock	1 5/16-16	150 min.
Screw	Pinion Bearing Lock Sleeve Lock	1/2-20	35-40
Nut	Bearing Lock Sleeve Lock Screw	1/2-20	15-20
Bolt	Differential Carrier Bearing Cap	9/16-12	90-100
Bolt	Cover to Axle Housing	3/8-24	10-15
Bolt	Differential Carrier to Axle Housing	3/8-24	20-25
Bolt	Torque Tube to Differential Carrier	7/16-14	65-70
Bolt	Torque Tube to Torque Ball	9/8-16	20-25
Nut	Strut Rod to Bracket Bolt	1/2-20	60-65
Nut	Strut Rod to Bracket or Spacer	3/8-16	30-35
Bolt	Chassis Spring Lower End to Spring Seat	1/2-20	55-60
Bolt	Chassis Spring Upper End to Frame	1/2-20	15-20
Nut	Radius Rod Pin Support to Axle	1/2-20	35-40
Nut	Radius Rod Front and Rear Support to Spring Seat	3/8-24	20-25
Nut	Radius Rod Bracket to Frame	7/16-20	30-35
Nut	Rear Shock Absorber Link Stud to Arm	3/8-24	20-25
Nut	Rear Brake Assembly to Axle Housing	7/16-20	35-40
Stud	Wheel Pilot to Axle Shaft	5/16-18	10-15
Bolt	Wheel to Rear Axle Shaft	9/16-18	70-75

#### b. General Specifications

Items	Series 40-50	Series 70
Rear Axle Type	← Semi-Floating, Hypoid →	← Through Torque Tube →
Drive and Torque	← 4 pts. →	← 4 pts. →
Rear Axle Oil Capacity	← See paragraph 1-8 →	
Rear Axle Oil Specifications	← See paragraph 1-8 →	

Items	Series 40-50	Series 70
Ring and Pinion Gear Set—Type	← Hypoid →	
Ring Gear Attached to Case	← 12 Cold-Headed Rivets →	
Ring Gear Lash Adjustment	← 2 Threaded Adjusters →	
Pinion Fore and Aft Adjustment	← Shims →	
Differential Side Gears & Pinions—Number	← 2 Gears—2 Pinions →	
Type	← Revacycle →	

### c. Rear Axle Ratios

NOTE: The rear axle ratio is indicated by a number stamped on bottom center of axle housing.

$$\frac{3}{6} = 3.6 \text{ to } 1, \frac{3}{9} = 3.9 \text{ to } 1, \frac{4}{1} = 4.1 \text{ to } 1.$$

Model	Synchromesh		Dynaflo	
	Standard	Optional	Standard	Optional
41, 41D, 45R, 46, 46S, 48, 48D, 51, 56R, 56S	3.9 to 1 (43-11)	3.6 to 1 (47-13)	3.6 to 1 (47-13)	3.9 to 1 (43-11)
46C, 52, 56C, 72, 76C, 76R	4.1 to 1 (41-10)	3.9 to 1 (43-11)	3.9 to 1 (43-11)	3.6 to 1 (47-13)
59, 79	4.1 to 1 (41-10)	No Option	3.9 to 1 (43-11)	No Option

### d. Limits for Fitting and Adjustment of Parts

NOTE: Limits on fit of parts are for new parts only. "T" means tight and "L" means loose.

	Series 40-50	Series 70
Axle Shaft End Play	← .000" to .008" →	
Backlash, Ring Gear—Desired	← .008" to .010" →	
Min. and Max.	← .008" to .012" →	
Backlash, Side and Pinion Gears	← .000" to .008" →	
Clearance, Side Gear to Axle Shaft	← .0035"L to .0005"T →	
Differential Bearing Preload, Notches Tight on Adjuster, from "Free" Position	← 2½ to 3 →	
Differential Case Flange Run-Out, Maximum	.002"	.002"
Differential Side Bearing—In Carrier	← .0003"L to .0019"L →	
On Case	← .0012"T to .0027"T →	
Pinion Bearing Lock Sleeve—In Carrier	← .002"L to .017"L →	
Pinion Shaft Front Bearing—In Carrier	← .0006"T to .0005"L →	
On Pinion	← .000" to .001"T →	
Pinion Shaft Rear Bearing—In Carrier	← .000" to .0011"T →	
Pinion Shaft Rear Bearing Clearance on Pinion	← Selected Fit →	
Desired, After Assembly	.0005"	.0005"
Maximum, After Assembly	.0014"	.0014"
Pinion Setting, Micrometer Reading—with Gauge	← See fig. 5-26 →	
Allowable Variation	±.001"	±.001"
Pinion Shaft Spline in Propeller Shaft	← .0016"T to .0009"L →	
Propeller Shaft and Pinion Assembly, Allowable Run-Out	← See Fig. 5-21 →	
Ring Gear Run-Out, Maximum, When Installed on Case	.003"	.003"
Wheel Bearing—In Housing	← .0008"T to .0013"L →	
Wheel Bearing on Axle Shaft, Bearing Pressed Into Housing	← .000" to .0031"L →	

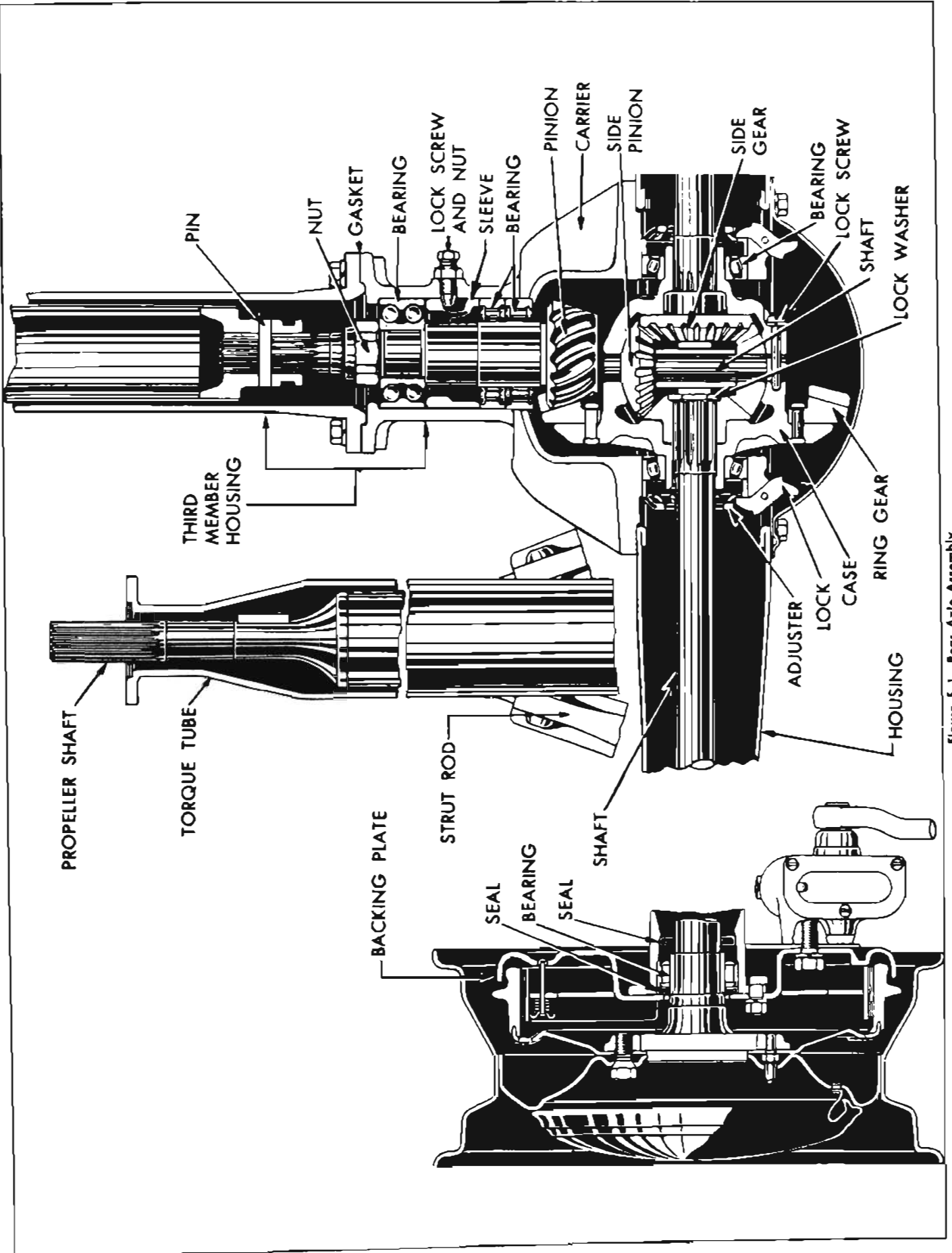

Figure 5-1—Rear Axle Assembly

**5-2 DESCRIPTION OF REAR AXLE**

The rear axle assembly is the semi-floating type in which the load is carried on the axle shafts through bearings enclosed in the axle housing. See figure 5-1. It has a torque tube drive and a Hypoid type spiral bevel ring gear and pinion set in which the centerline of the pinion is below the centerline of the ring gear. See figure 5-19.

The torque tube is joined to the differential carrier to form a unit assembly called the third member housing; the torque tube and carrier are not serviced separately. This is because a straightening operation is necessary to line up the pinion bearing holes with front flange pilot on torque tube. The third member housing is bolted to the banjo type rear axle housing. Two rear axle strut rods form braces between the front end of the third member housing and the outer ends of the axle housing to hold third member square with axle housing. The torque tube encloses the propeller shaft which is rigidly connected to the pinion through a splined joint and a pin. See figure 5-1.

The pinion is supported in the differential carrier by two Hyatt roller bearings (rear) and a New Departure double-row radial-thrust ball bearing (front) which is secured to the shaft by a large lock nut staked in place.

The pinion and bearing assembly is held in position by a pinion bearing lock sleeve and

three cone-pointed lock screws which clamp the double-row ball bearing against a shoulder in the carrier. Shims placed between the bearing and the shoulder provide correct relation of the pinion with ring gear. See figure 5-1.

The ring gear is riveted to the differential case which is supported in the differential carrier with two differential side bearings. Threaded adjusters bearing against the outer races of the side bearings provide means of adjusting ring gear lash. The differential case also houses two differential bevel side gears in mesh with two differential bevel side pinions mounted on a shaft which is anchored in the case by a lock screw. See figure 5-1.

The splined inner ends of the axle shafts are supported by the differential side gears. "Horse-shoe" washers retain the axle shafts in the side gears; washers are held in recesses in side gears when differential pinion spacer is installed. The pinion spacer is located between the inner ends of the shafts and controls end play of axle shafts. The outer ends of the axle shafts are supported in the axle housing by Hyatt roller bearings. Seals are provided on both sides of each roller bearing to exclude dirt and to prevent leakage of oil upon the brakes.

Rear axle is equipped with either standard or optional gear ratios. See paragraph 5-1. The rear axle ratio is indicated by numbers stamped on underside of axle housing.