

## SECTION 10-J WIRING CIRCUIT DIAGRAMS

### DIAGRAMS IN SECTION 10-J

Figure	Wiring Circuit Diagram	Page	Figure	Wiring Circuit Diagram	Page
10-107	Chassis—Series 40 Without Direction Signals	10-90	10-116	Body—Model 51—Style 4569	10-95
10-108	Chassis—Series 40 With Direction Signals	10-91	10-117	Body—Model 56S—Style 4507	10-96
10-109	Chassis—Series 50-70	10-92	10-118	Body—Model 56R—Style 4537	10-96
10-110	Dome Lamp—Series 40	10-93	10-119	Body—Models 52, 72R—Styles 4519, 4719	10-97
10-111	Dome Lamp—Models 51, 56C, 56R, 56S, 76C, 76R	10-93	10-120	Body and Hydro-Lectric—Models 52, 72R—Styles 4519X, 4719X	10-97
10-112	Dome Lamp—Models 52, 72R	10-93	10-121	Body and Hydro-Lectric—Models 56C, 76C—Styles 4567X, 4767X	10-98
10-113	Body—Models 41, 41D—Styles 4369, 4369D	10-94	10-122	Body and Hydro-Lectric—Model 76R—Style 4737X	10-98
10-114	Body—Models 46, 46S—Styles 4327B, 4327	10-94	10-123	Body—Models 59, 79—Styles 4581, 4781	10-99
10-115	Body—Models 48, 48D—Styles 4311, 4311D	10-95			

### SERVICE BULLETIN REFERENCE

Bulletin No.	Page No.	SUBJECT

### 10-69 CIRCUIT DIAGRAMS, INSPECTION HOLE, AND FUSE BLOCK

This Section contains all the necessary wiring circuit diagrams for chassis and body. The wiring may be easily traced by paying attention to the color code on each wire and the color code indicated on the diagrams.

Many of the wiring connections use a push-pull type terminal. The terminal plug on the wire requires a hard push to seat it in the socket. A hard steady pull on the wire is required to detach the terminal plug from the socket. If an exceptionally hard pull is required, it is advisable to start the terminal plug by prying against the rim with a screwdriver.

An inspection hole is located in the left side of dash panel. The cover, which is attached by screws, may be quickly removed for inspection and for working on the wiring connections to instruments on forward side of instrument panel.

A central fuse block is mounted under the cowl near the steering column and to rear of

the inspection hole in cowl. It is not necessary, however, to remove the inspection hole cover to replace a fuse or to disconnect wires. The fuse block serves as a convenient junction point for a number of wiring circuits, provides a mounting for the direction signal flasher, and contains the fuses shown in figure 10-109. The "Direction Signal" fuse also protects the stop light circuits. The "Dome Lamp" fuse also protects the luggage compartment and glove box lamp circuits.

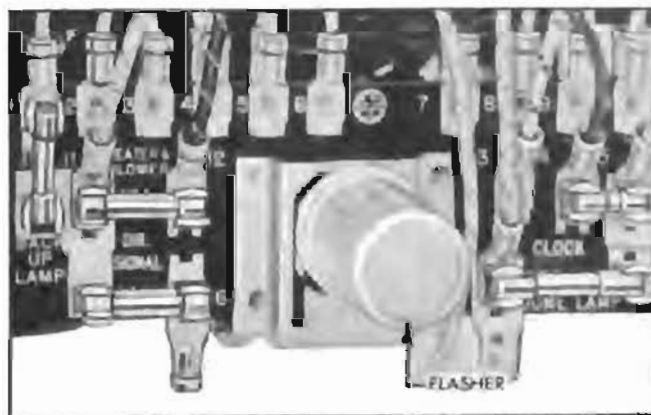
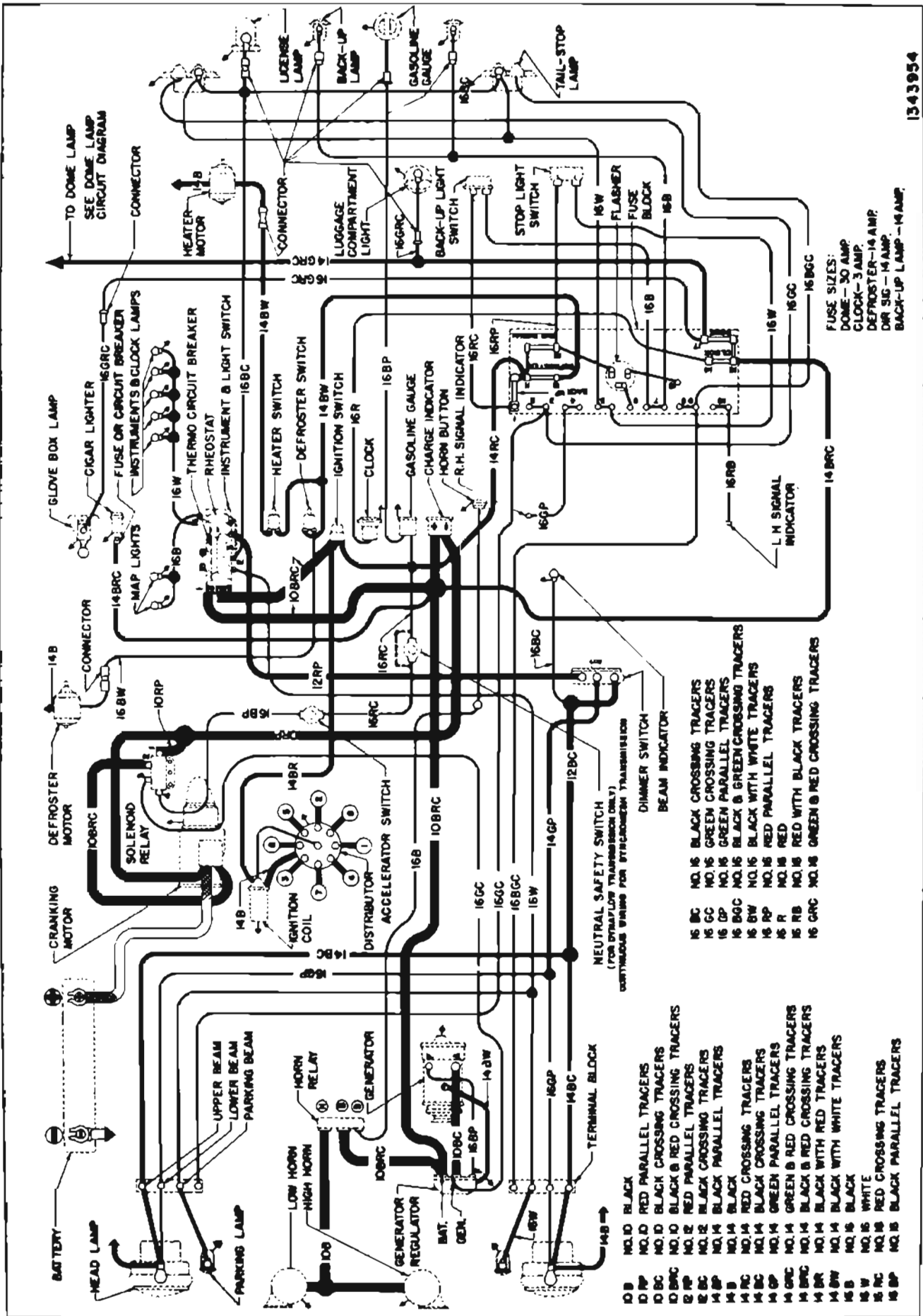
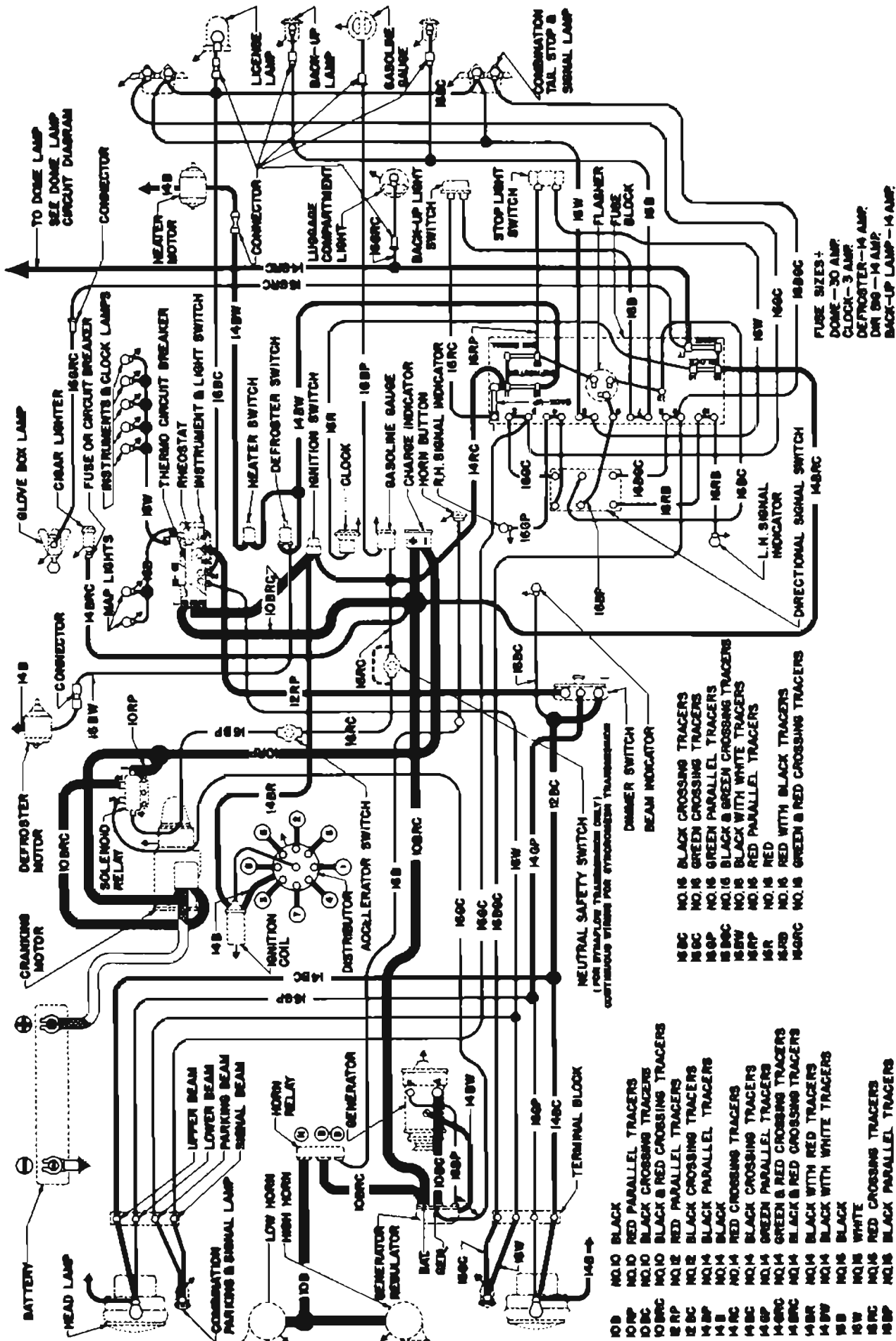

Figure 10-106—Fuse Block, With Direction Signals



1343954

Figure 10-107—Chassis Wiring Circuit Diagram—Series 40 Without Direction Signals



1343955

Figure 10-108—Chassis Wiring Circuit Diagram—Series 40 With Direction Signals

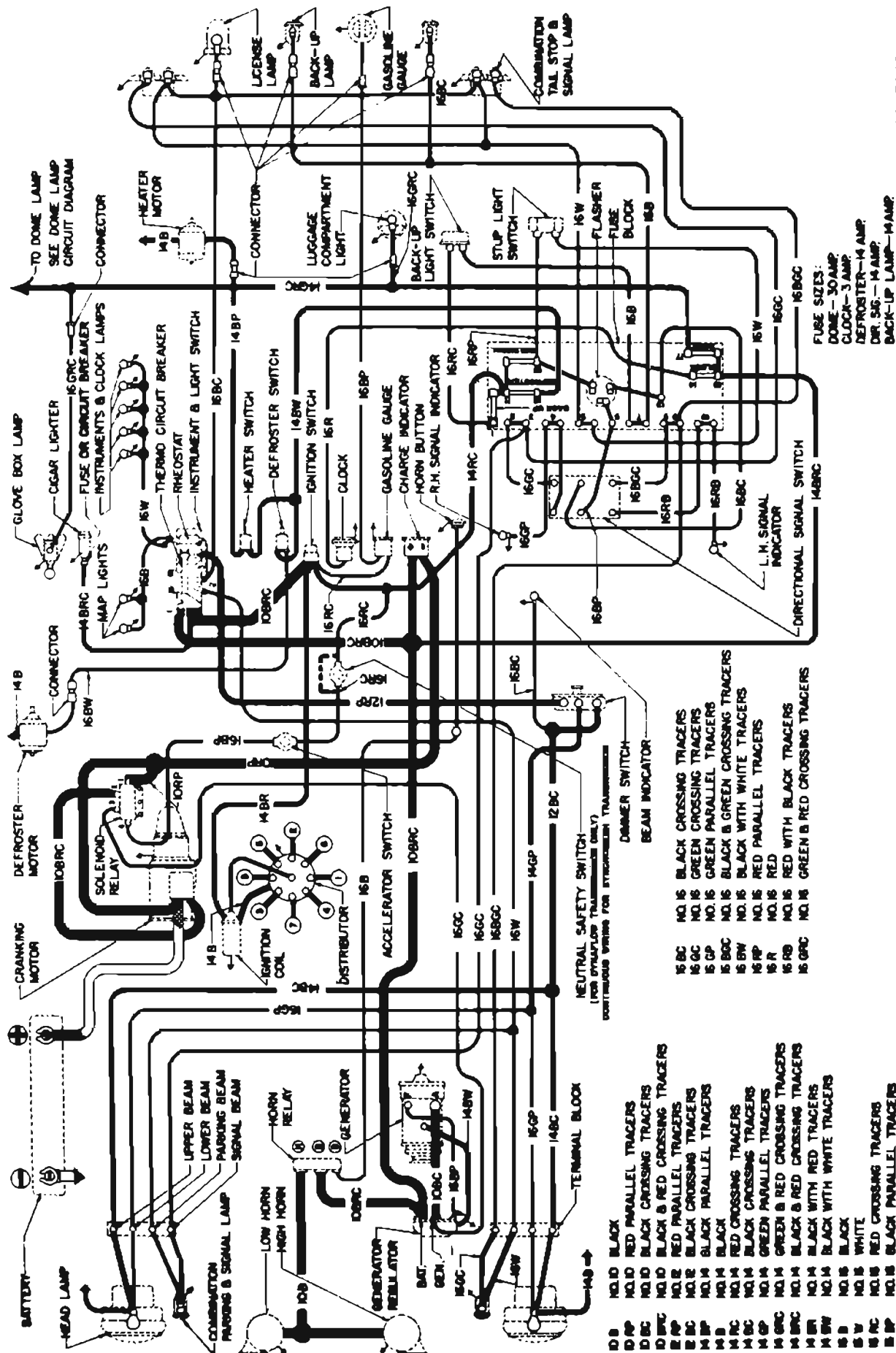

1343249

Figure 10-109—Chassis Wiring Circuit Diagram—Series 50-70

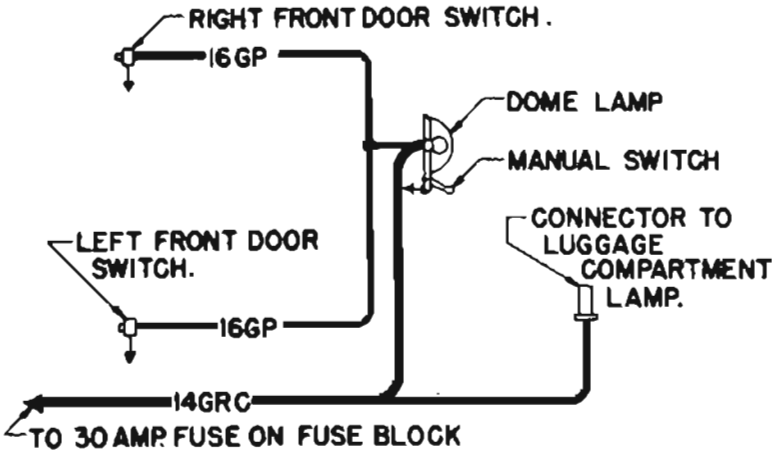

14GRC NO.14 GREEN & RED CROSSING TRACERS.  
 16GP NO.16 GREEN PARALLEL TRACERS.

Figure 10-110—Dome Lamp Wiring Circuit Diagram—Series 40

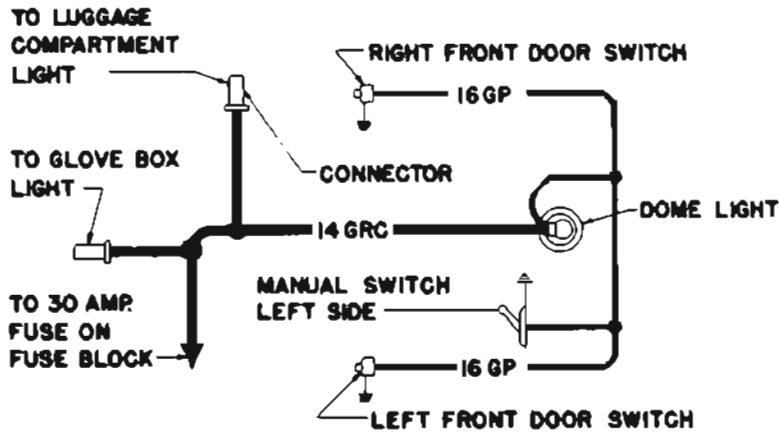

14GRC NO.14 GREEN & RED CROSSING TRACERS.  
 16GP NO.16 GREEN PARALLEL TRACERS.

Figure 10-111—Dome Lamp Wiring Circuit Diagram—Models 51, 56C, 56R, 56S, 76C, 76R

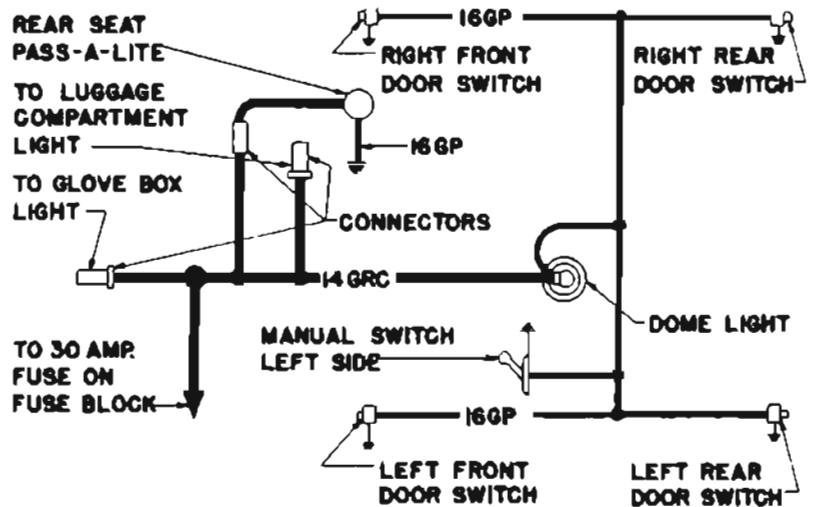

14GRC NO.14 GREEN & RED CROSSING TRACERS  
 16GP NO.16 GREEN PARALLEL TRACERS

Figure 10-112—Dome Lamp Wiring Circuit Diagram—Models 52 and 72R

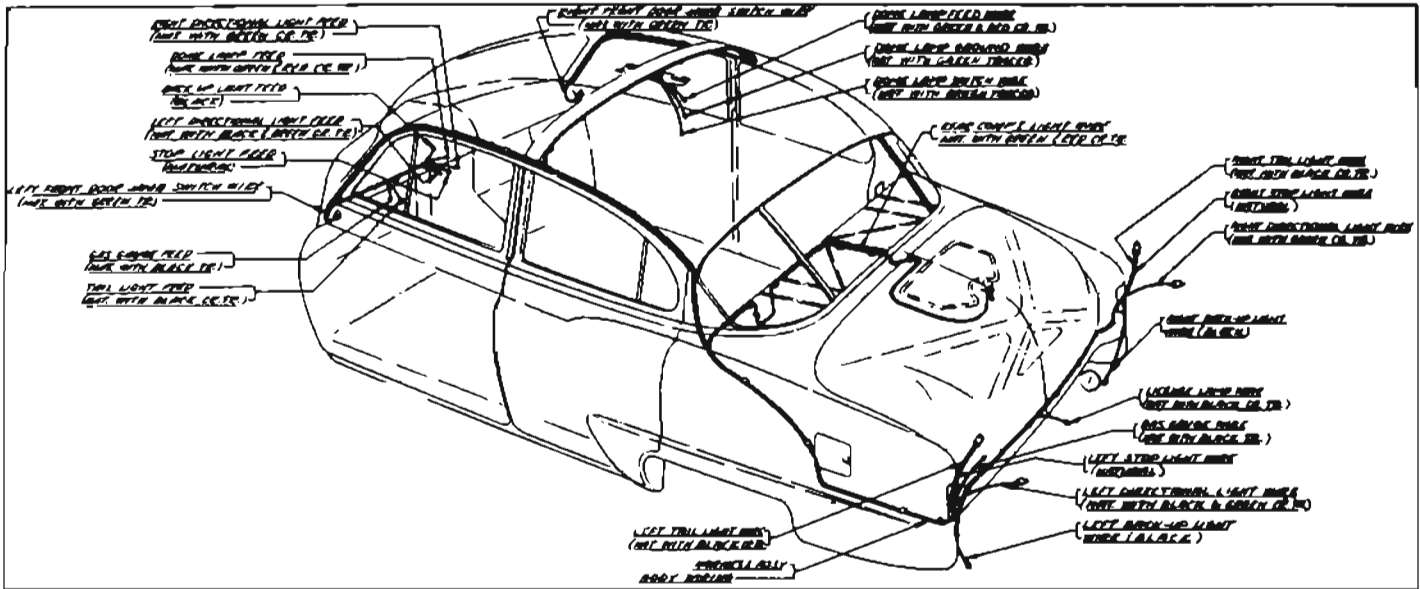

Figure 10-113—Body Wiring Circuit Diagram—Models 41, 41D—Styles 4369, 4369D

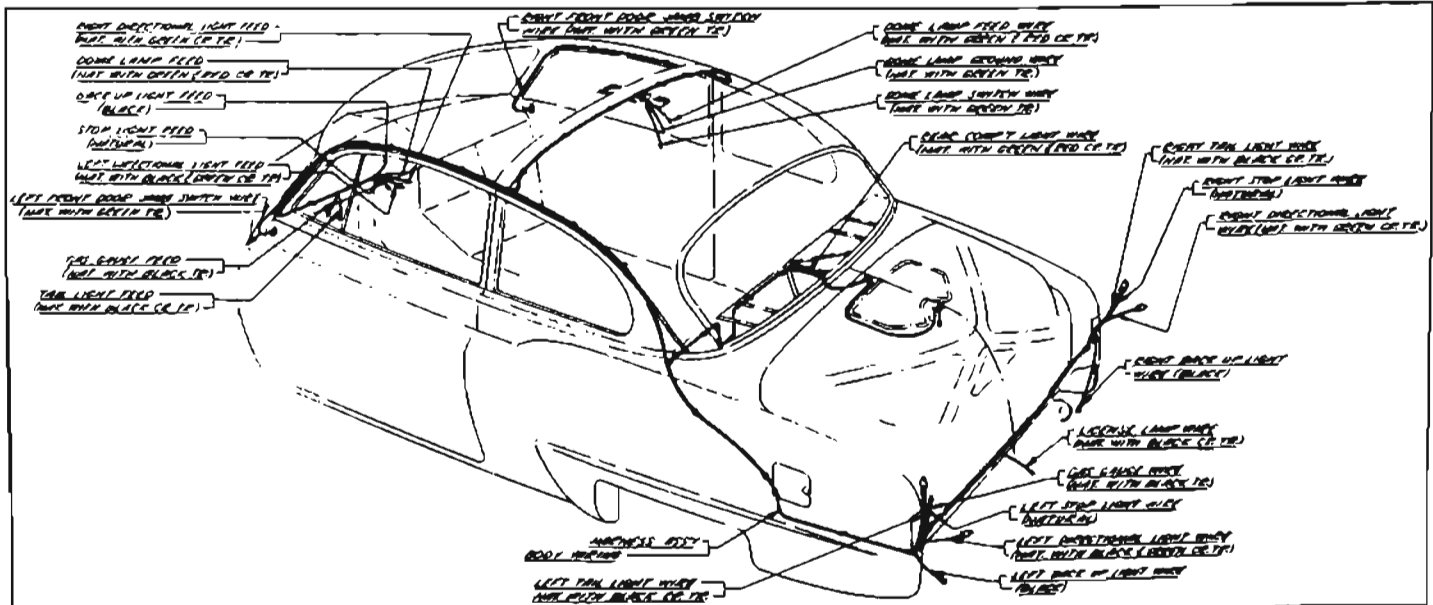

Figure 10-114—Body Wiring Circuit Diagram—Models 46, 46S—Styles 4327B, 4327

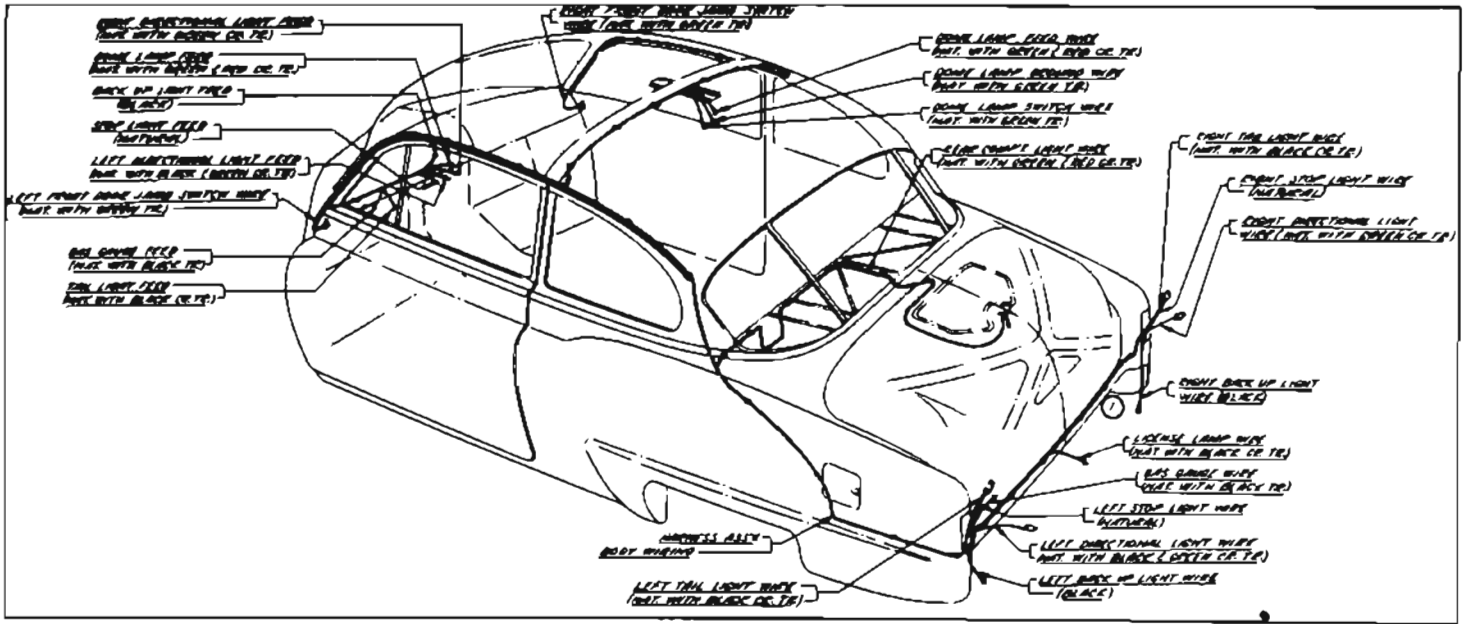

Figure 10-115—Body Wiring Circuit Diagram—Models 48, 48D—Styles 4311, 4311D

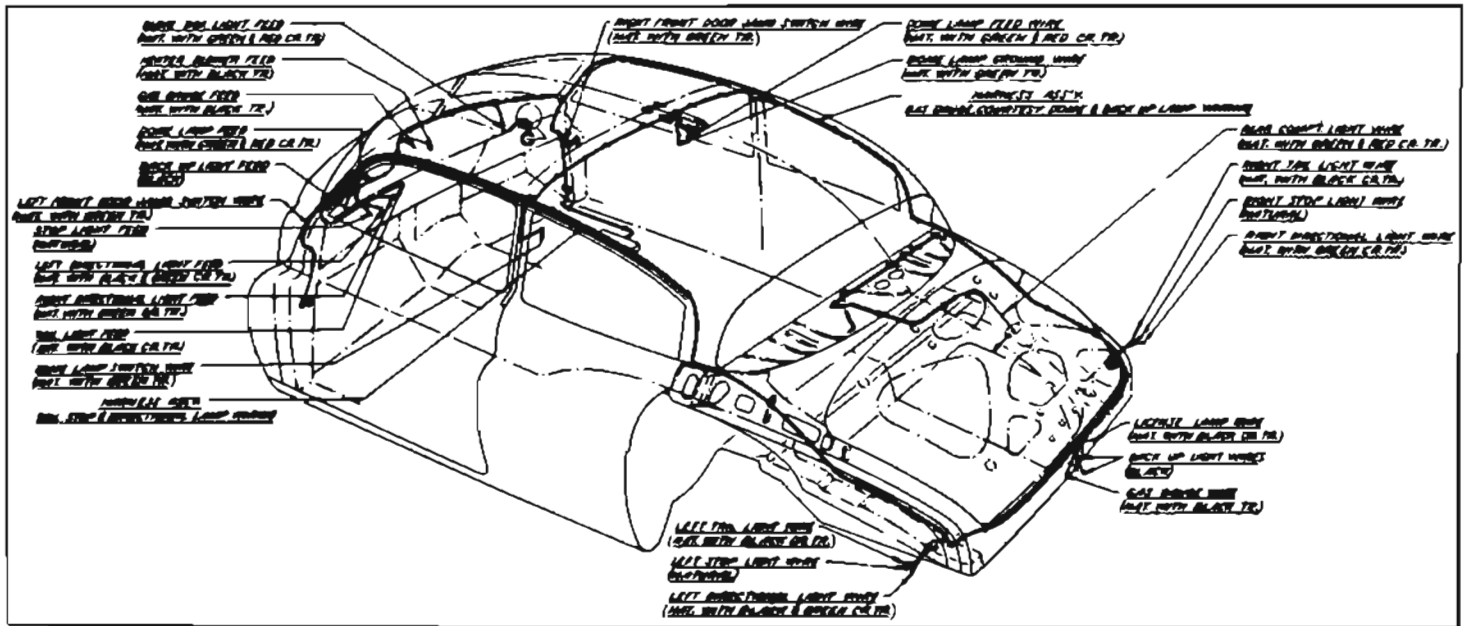

Figure 10-116—Body Wiring Circuit Diagram—Model 51—Styles 4569

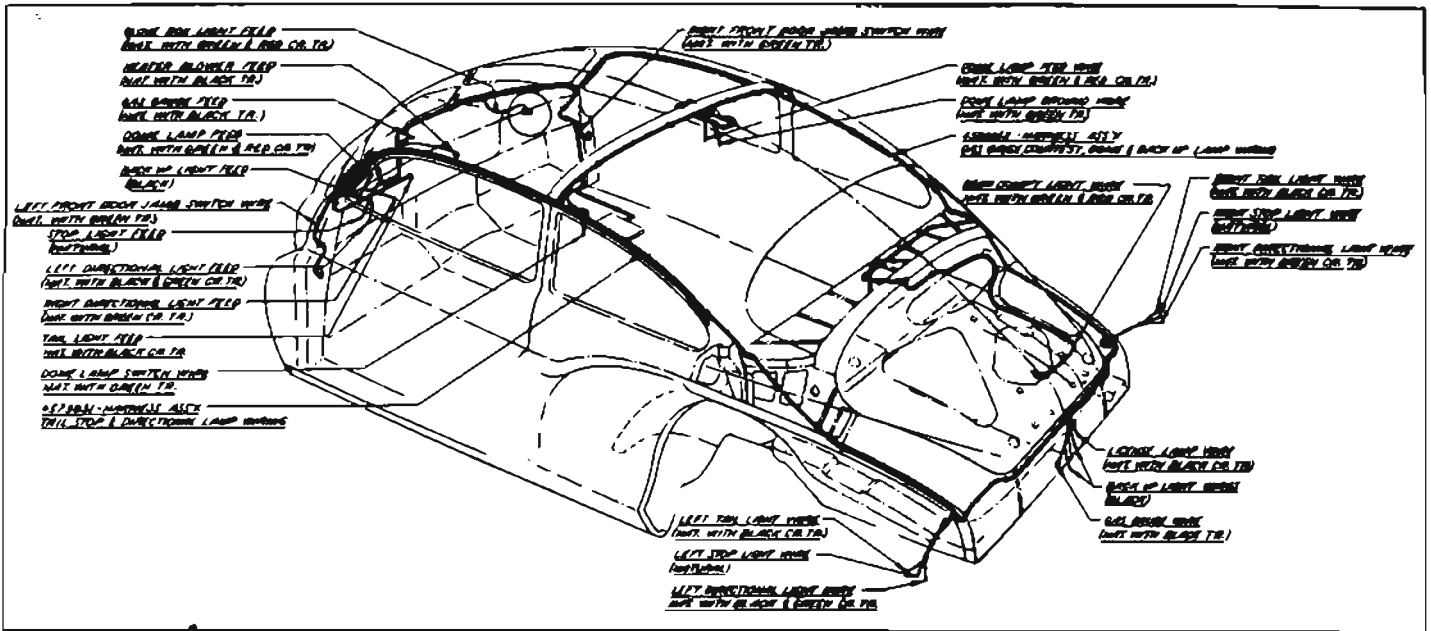

Figure 10-117—Body Wiring Circuit Diagram—Model 56S—Style 4507

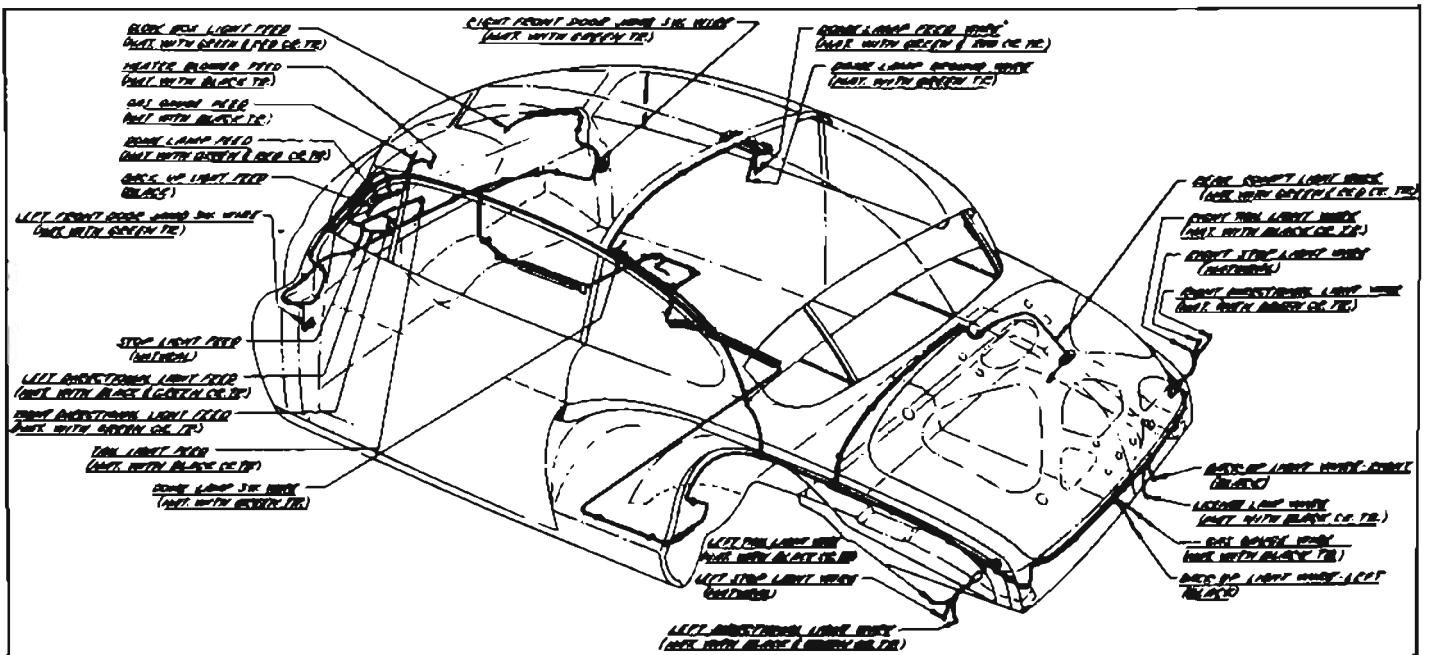

Figure 10-118—Body Wiring Circuit Diagram—Model 56R—Style 4537



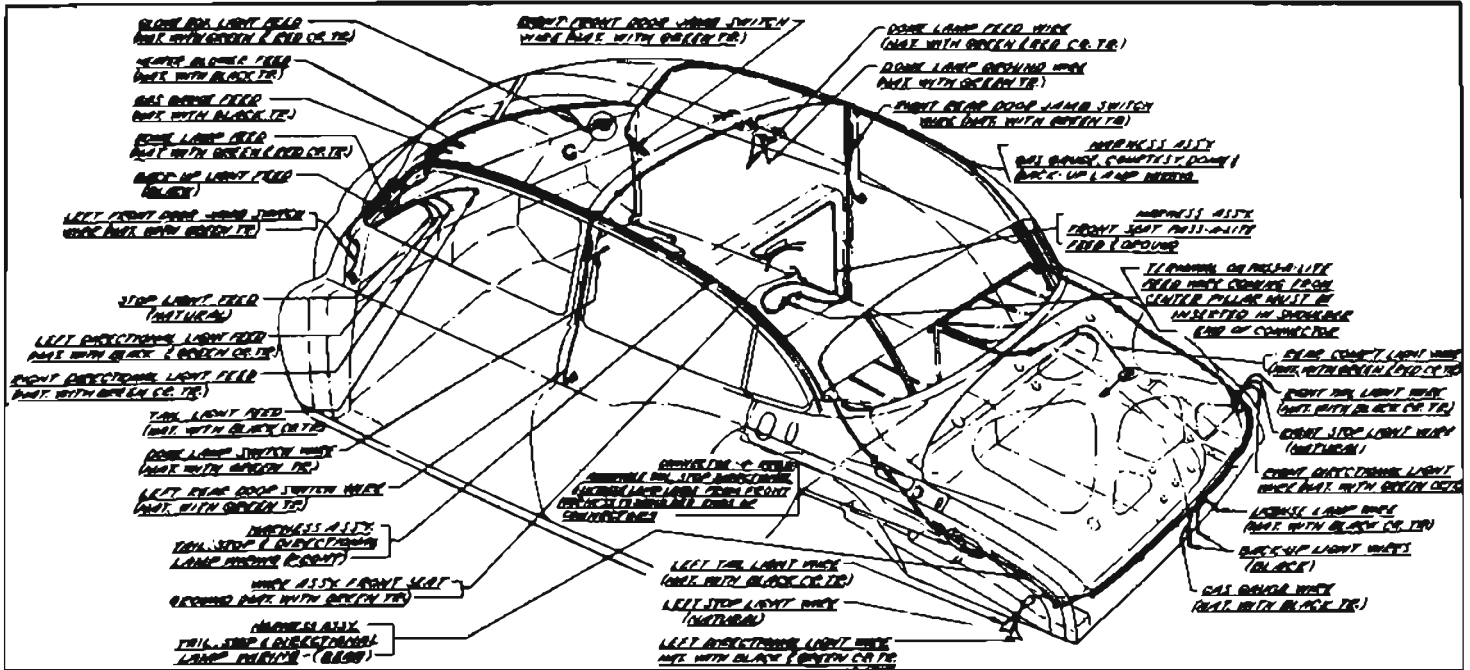

Figure 10-119—Body Wiring Circuit Diagram—Models 52, 72R—Styles 4519, 4719

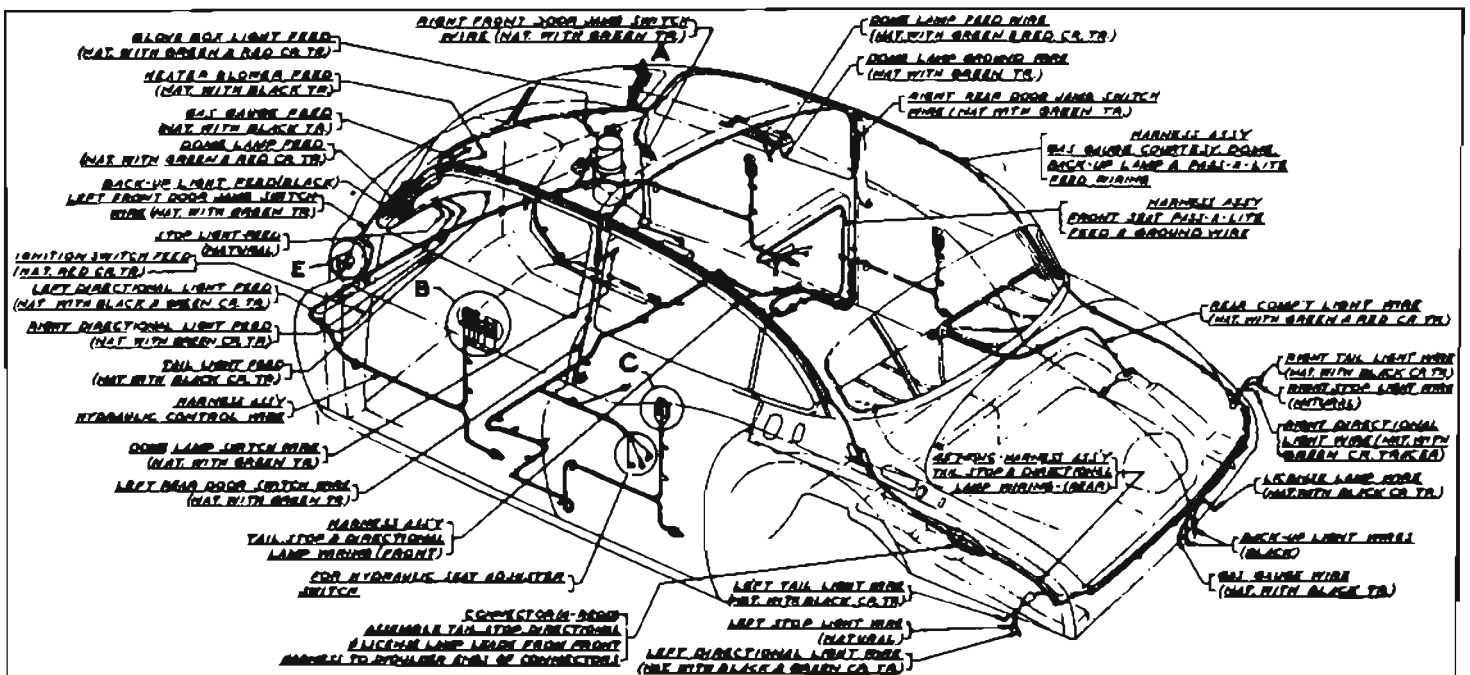

Figure 10-120—Body and Hydro-Electric Wiring Circuit Diagram—Models 52, 72R—Styles 4519X, 4719X

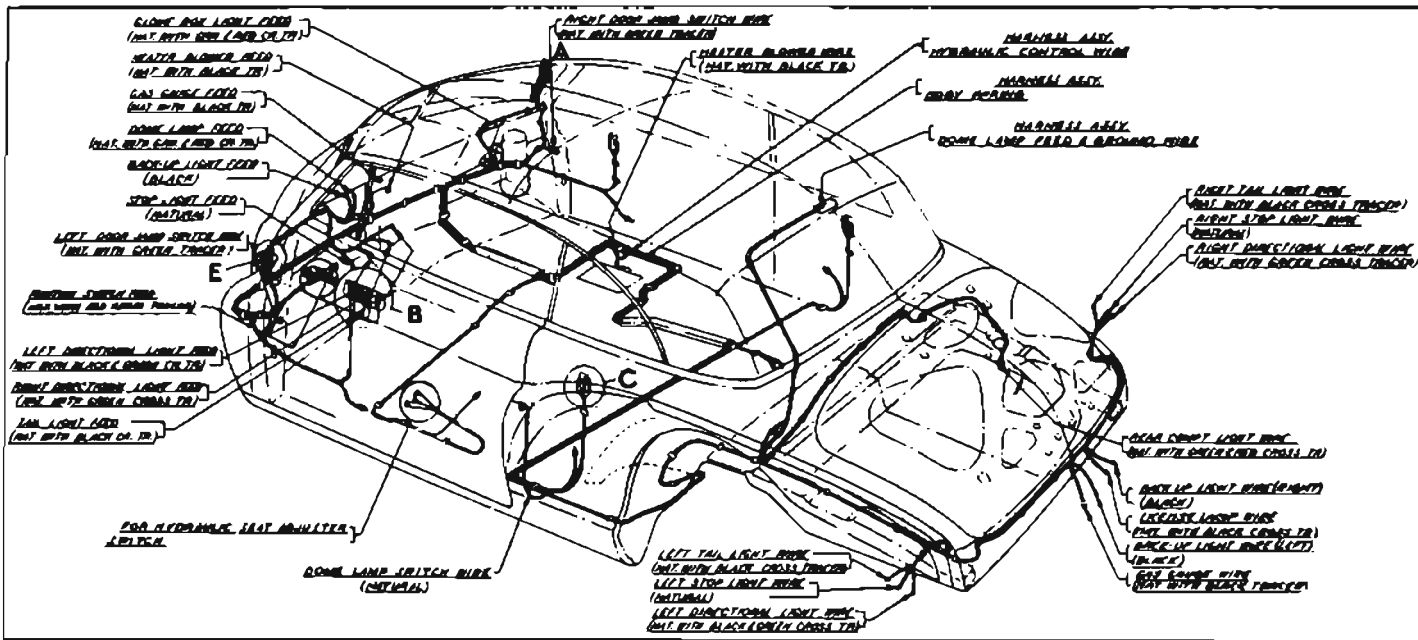
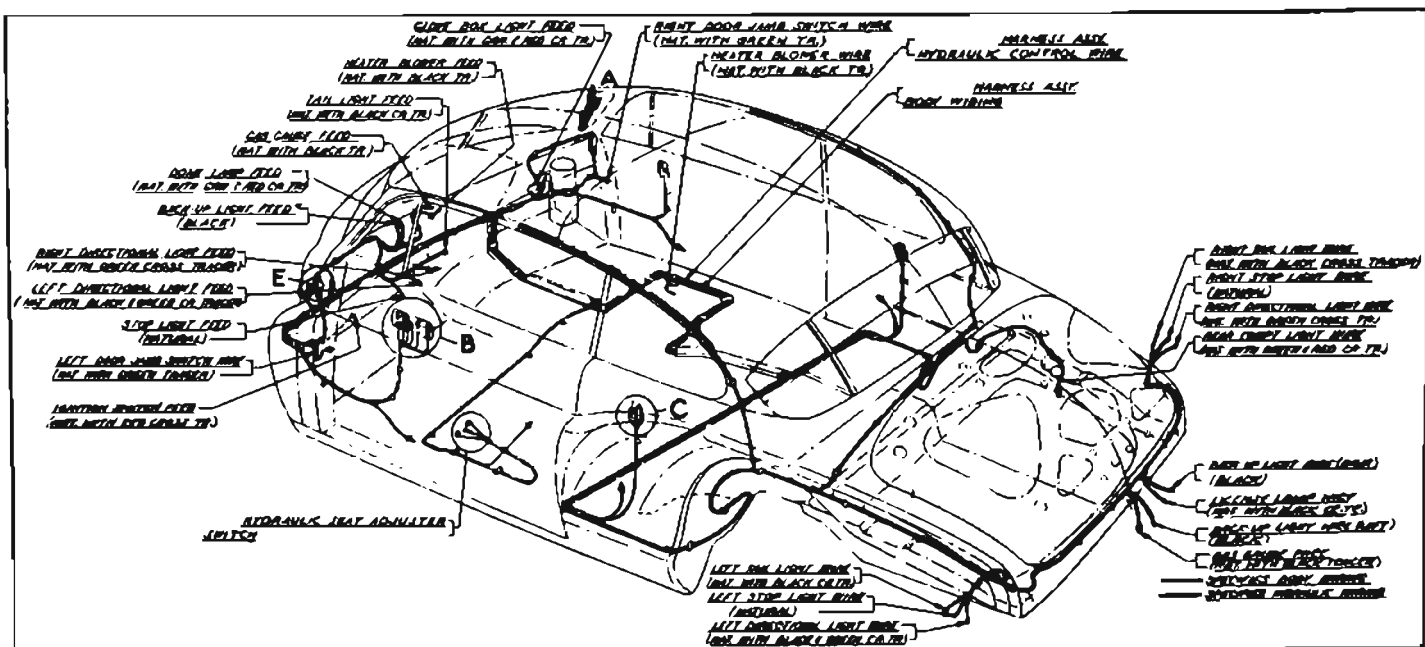

Figure 10-121—Body and Hydro-Lectric Wiring Circuit Diagram—Models 56C, 76C—Styles 4567X, 4767X



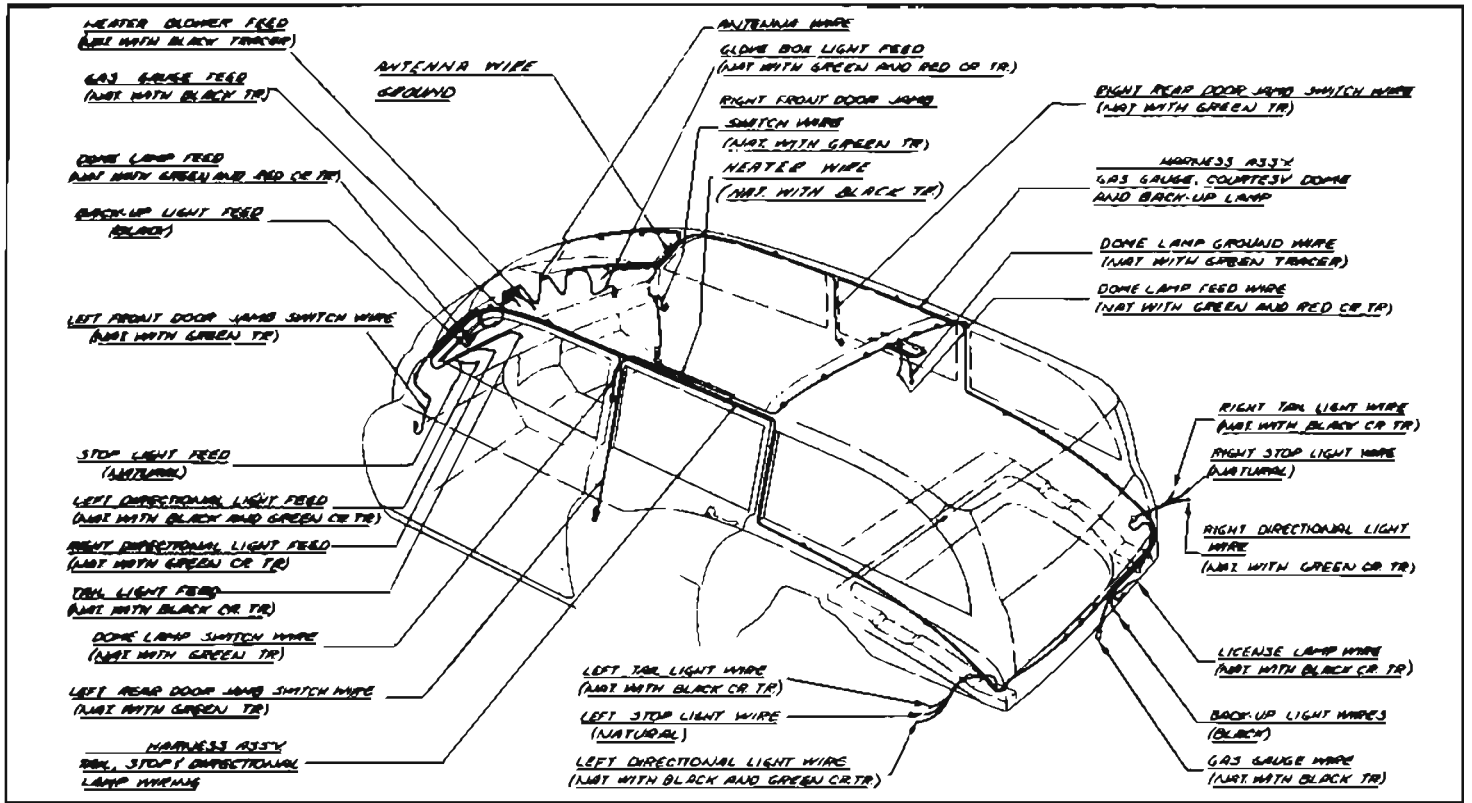

Figure 10-123—Body Wiring Circuit Diagram—Models 59, 79—Styles 4581, 4781



Model 72R



Model 76C

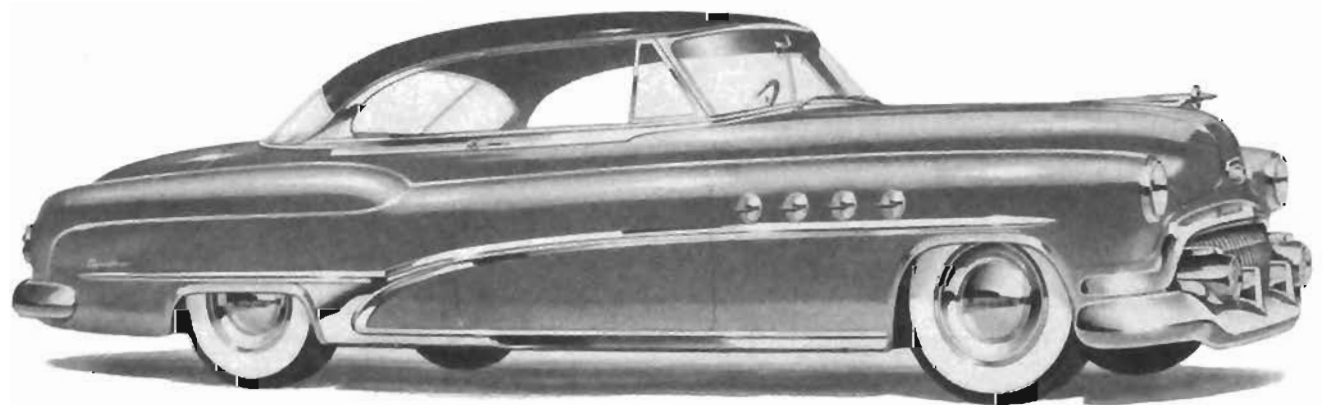

Model 76R