

SECTION D

45-46-48-49000 PROPELLER SHAFT

CONTENTS

Division	Paragraph	Subject	Page
I	41-11	SPECIFICATIONS AND ADJUSTMENTS: Propeller Shaft Specifications	40-37
II	41-12 41-13	DESCRIPTION AND OPERATION: Description of Propeller Shaft, 45-46-48000 Description of Propeller Shaft, 49000	40-38 40-42
III	41-14 41-15 41-16 41-17 41-18 41-19 41-20	SERVICE PROCEDURES: Removal of Propeller Shaft Disassembly of Propeller Shaft Assembly Assembly of Propeller Shaft Installation of Propeller Shaft Adjustment of Rear Universal Joint Angle, 45-46-48000 Adjustment of Rear Universal Joint Angle, 49000 Propeller Shaft Balancing Procedure	40-42 40-42 40-45 40-47 40-48 40-49 40-51
IV	41-21	TROUBLE DIAGNOSIS: Propeller Shaft Trouble Diagnosis	40-53

DIVISION I SPECIFICATIONS AND ADJUSTMENTS

41-11 PROPELLER SHAFT SPECIFICATIONS

a. Tightening Specifications

Use a reliable torque wrench to tighten the parts listed, to insure proper tightening without straining or distorting parts. These specifications are for clean and lightly lubricated threads only; dry or dirty threads produce increased friction which prevents accurate measurement of tightness.

Part	Location	Thread Size	Torque Lbs. Ft.
Bolt and Nut	Center Bearing Support to Frame 45-46-48000	5/16-18	20
Bolt	Center Bearing Support to Frame 49000	5/16-24	20
Nut	Clamp, Rear U-Joint to Pinion Flange 45-46-48000	5/16-18	12
Bolt	Rear CV Joint to Pinion Flange 49000	7/16-14	85
*Nut	Upper and Lower Control Arm	1/2-13	80
*Bolt	Upper and Lower Control Arm	1/2-13	110
*Nut and Bolt	Upper Control Arm Vernier Adjustment (49000)	7/16-14	48
Nut and Nut	Upper Control Arm Bracket to Frame 45-46-48000	3/8-16	30
Nut	Slip Joint Locking	Special	60

*Torquing of Nut or Bolt to be optional

b. General Specifications

Item	All Series (Except as Otherwise Noted)
Propeller Shaft	2 Piece - Open Drive Line
Universal Joints, 45-46-48000	2 Single, 1 Double Constant Velocity
Universal Joints, 49000	1 Single, 2 Double Constant Velocity

DIVISION II

DESCRIPTION AND OPERATION

41-12 DESCRIPTION OF PROPELLER SHAFT, 45-46-48000

The propeller shaft assembly consists of a front propeller shaft, a rear propeller shaft, a standard universal joint at each end and a double constant velocity type universal joint in the center. See Figure 40-54. A center support bearing attaches the rear end of the front propeller shaft to a center bearing support assembly which is mounted on a cross member between the right and left side rails of the frame. A splined front yoke on the front end of the rear propeller shaft extends into a splined coupling in the rear end of the front propeller

shaft. This slip spline permits the slight lengthening and shortening of the propeller shaft required by the up and down movement of the differential assembly. See Figure 40-55.

The constant velocity universal joint is composed of two single joints connected with a special link yoke. A center ball and socket between the joints maintains the relative position of the two units. See Figure 40-55. This center ball causes each of the two joints to operate through exactly one half of the complete angle between the front and rear propeller shafts. Because the two joint angles are the same, even though the usual universal joint fluctuation is present within the unit, the acceleration of the front joint is always neutralized by the deceleration of the rear joint, or vice versa. The end result is,

the front and rear propeller shafts always turn at a constant velocity.

The center support bearing consists of a sealed bearing, the inner race of which is held against a shoulder at the rear end of the front propeller shaft by a locknut. The center bearing outer race sets in a metal retainer which has a rubber support cushion bonded to it. The rubber open cup by a flat washer and a wire snap ring. The locknut which retains the center bearing in place also prevents the slip joint from separating. The seal which retains the lubricant in the slip spline is located inside the locknut. See Figures 40-55 and 40-56.

The propeller shaft assembly requires very little periodic service. The center support bearing

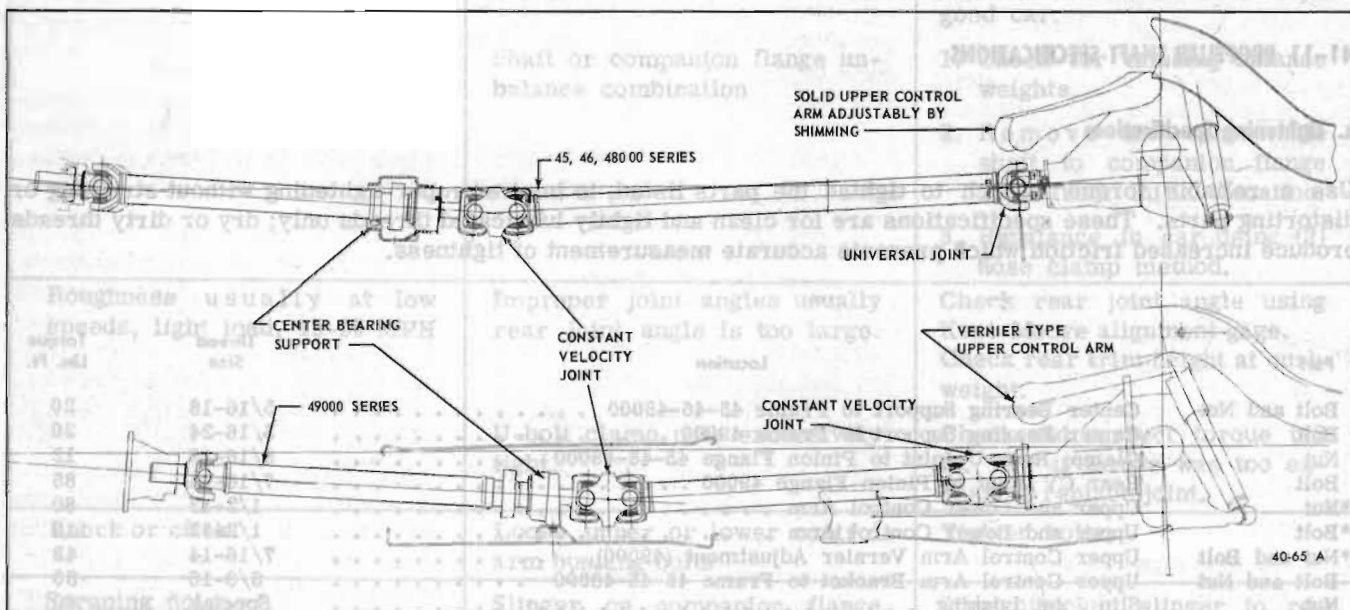

Figure 40-54—Propeller Shaft Assemblies

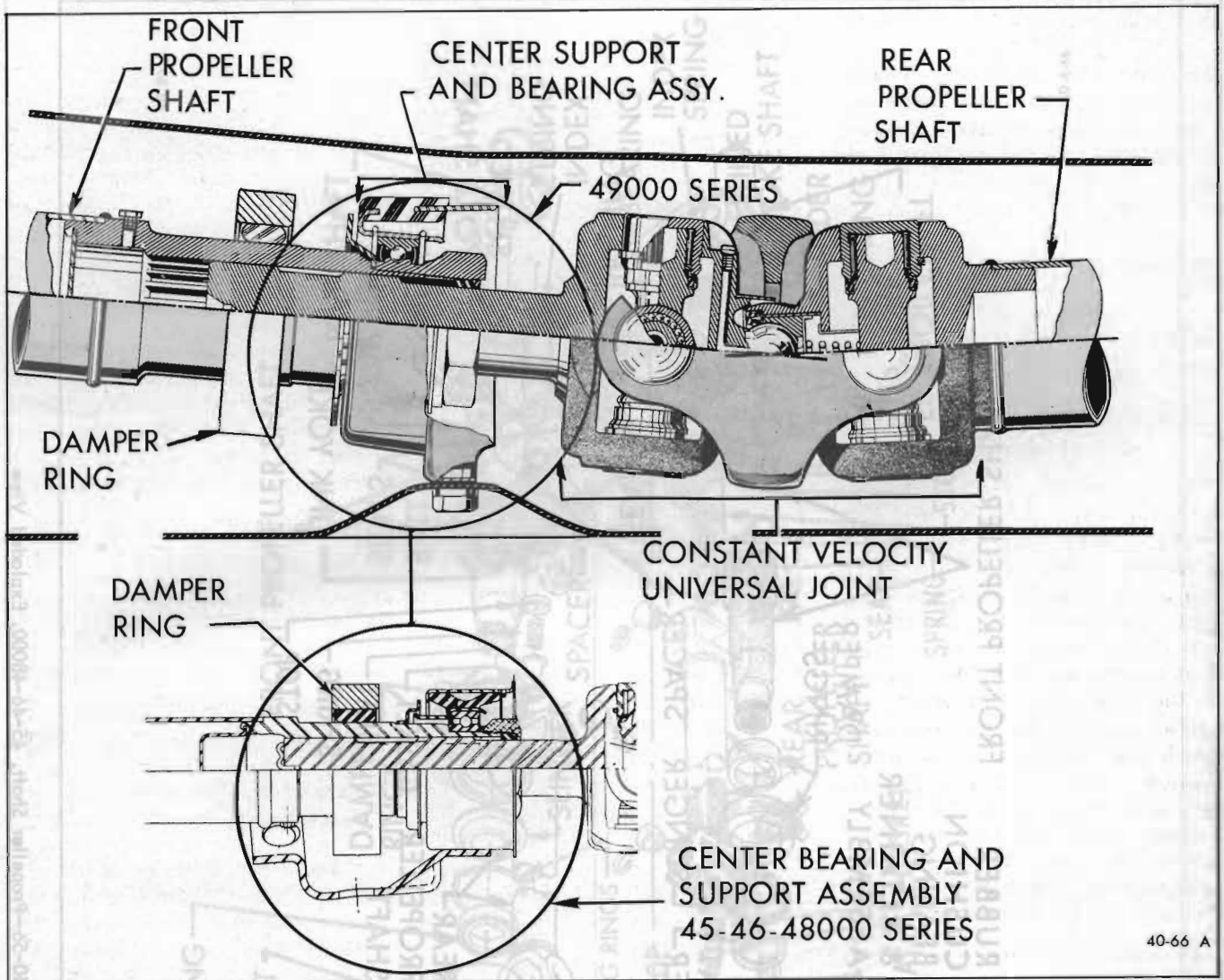

Figure 40-55—Center Support, Bearing and Constant Velocity Joint

is lubricated for life and requires no additional lubrication. All universal joints are lubricated for life and cannot be lubricated while in the car. If a joint becomes worn or noisy, a service kit must be installed which consists of a spider complete with bearing assemblies and snap rings.

Front and rear propeller shafts are not available separately, but only as a complete propeller shaft assembly; this is because the complete assembly must be given a careful rotating balance and this type of balancing equipment is not available in the field.

If any part of the propeller shaft requires repair, it is necessary to remove the complete propeller shaft assembly from the car. The assembly must be handled very carefully to avoid jamming or bending any of the parts.

If the car is to be undercoated, care must be taken to keep the propeller shaft completely free of undercoating material. Undercoating or any other material would upset the balance and might cause a serious vibration.

The center ball stud and seat should be lubricated every 6,000

miles with Multi-Purpose Grease EP No. 1 Grade.

The slip spline should also be lubricated with Multi-Purpose Grease EP No. 1 Grade every 6,000 miles or after disconnecting the slip joint for any reason. To lubricate the spline, remove the plug and install a grease fitting. When grease appears at the slip joint nut, remove the fitting and reinstall the plug. The plug must be in place as lubricant would be thrown out through the fitting by centrifugal force at high speeds.

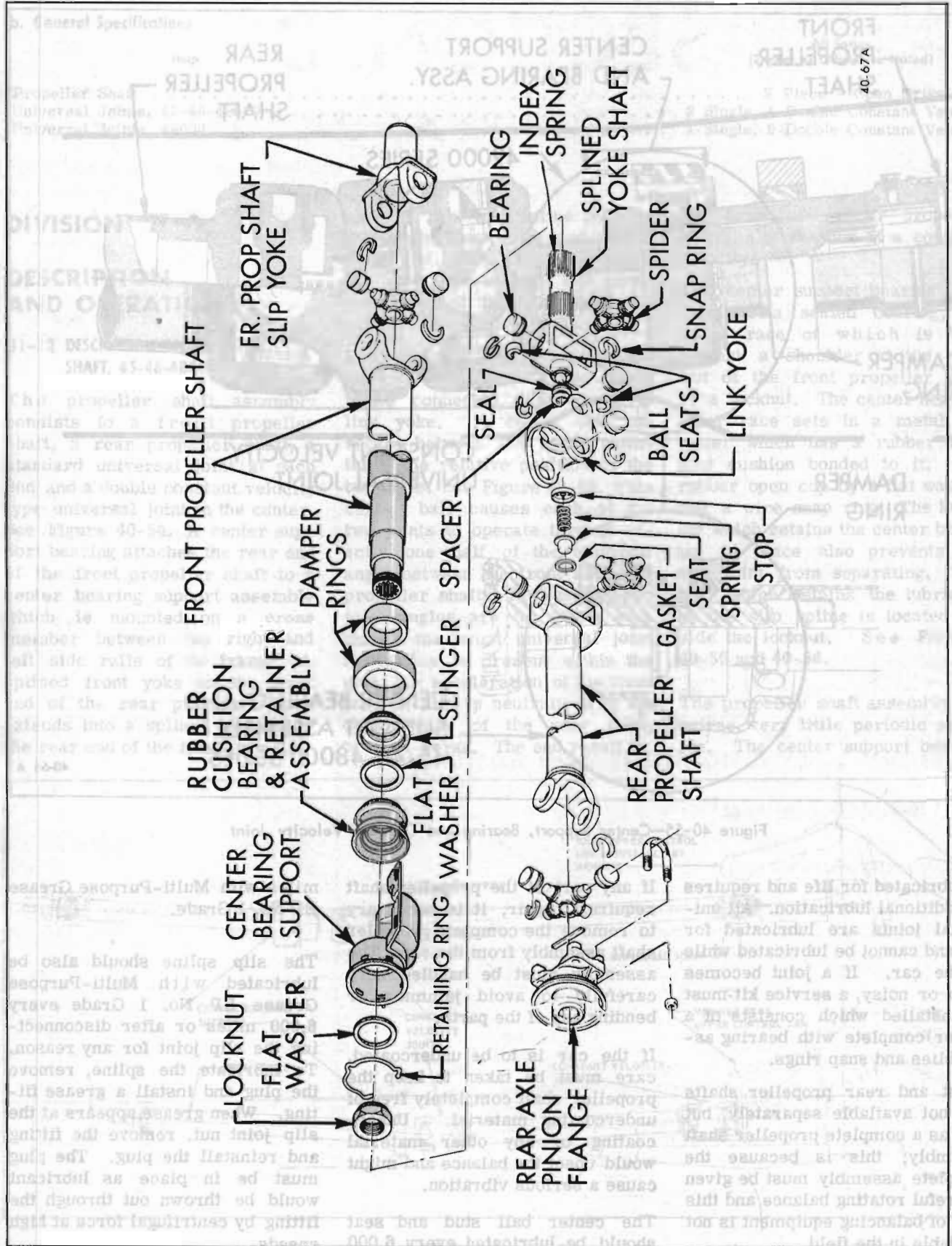

Figure 40-56—Propeller Shaft, 45-46-48000, Exploded View

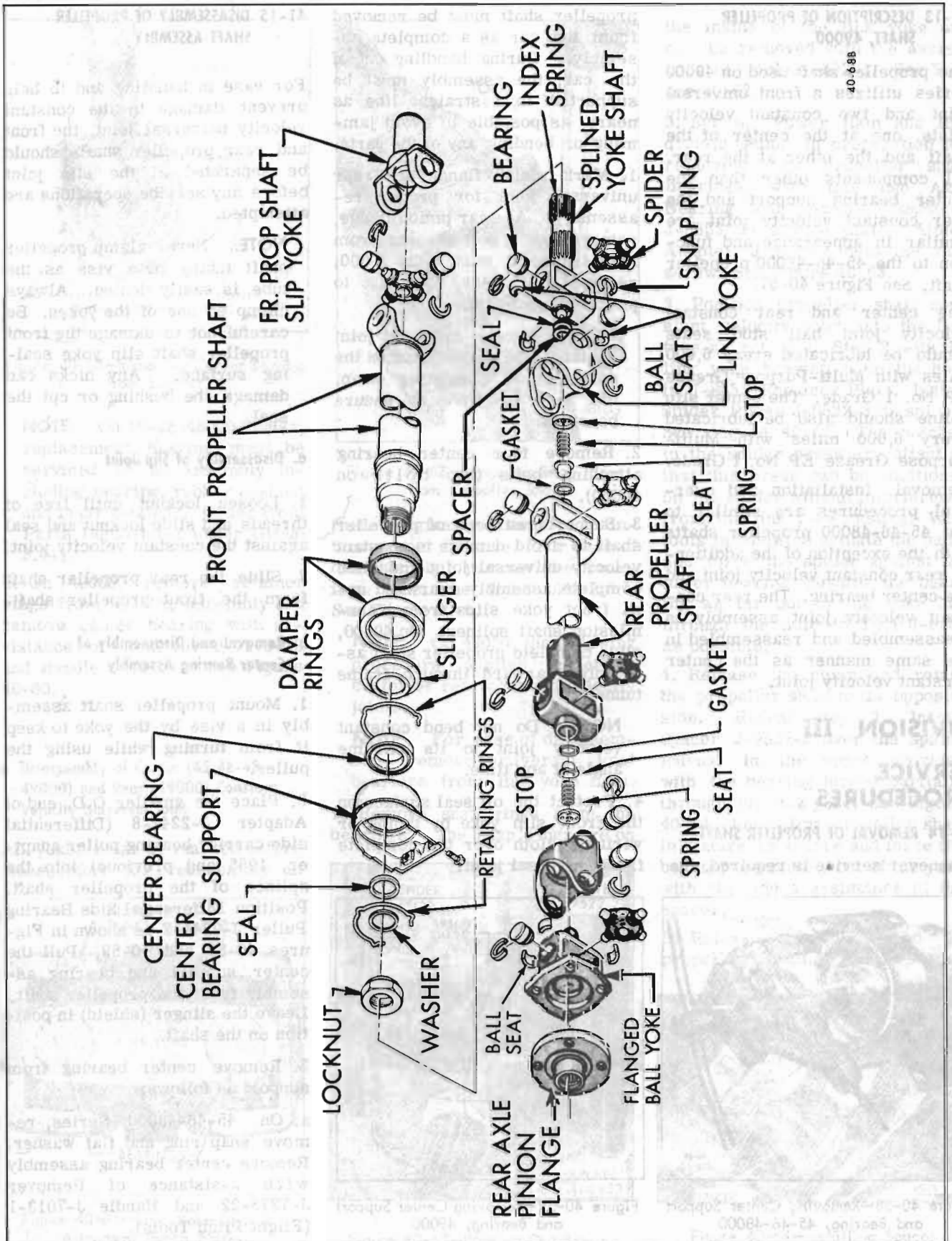

Figure 40-57—Propeller Shaft, 49000, Exploded View

41-13 DESCRIPTION OF PROPELLER SHAFT, 49000

The propeller shaft used on 49000 Series utilizes a front universal joint and two constant velocity joints, one at the center of the shaft and the other at the rear. All components other than the center bearing support and the rear constant velocity joint are similar in appearance and function to the 45-46-48000 propeller shaft. See Figure 40-57.

The center and rear constant velocity joint ball stud seats should be lubricated every 6,000 miles with Multi-Purpose Grease EP No. 1 Grade. The center slip spline should also be lubricated every 6,000 miles with Multi-Purpose Grease EP No. 1 Grade. Removal, installation and overhaul procedures are similar to the 45-46-48000 propeller shafts with the exception of the additional rear constant velocity joint and the center bearing. The rear constant velocity joint assembly is disassembled and reassembled in the same manner as the center constant velocity joint.

DIVISION III

SERVICE PROCEDURES

41-14 REMOVAL OF PROPELLER SHAFT

Whenever service is required, the

propeller shaft must be removed from the car as a complete assembly. During handling out of the car, the assembly must be supported in a straight line as nearly as possible to avoid jamming or bending any of the parts.

1. Mark pinion flange and rear universal joint for proper re-assembly. At rear pinion flange, remove "U" bolt clamps from rear universal joint. (On 49000, remove four rear CV joint to pinion flange bolts).

NOTE: If rear universal joint bearings are not retained on the spider by a connecting strap, use tape or wire to secure bearings.

2. Remove four center bearing attaching bolts (two bolts on 49000).

3. Support rear end of propeller shaft to avoid damage to constant velocity universal joint and slide complete assembly rearward until front yoke slips from transmission shaft splines. On 49000, slide complete propeller shaft assembly rearward through frame tunnel.

NOTE: Do not bend constant velocity joint to its extreme angle at any time.

4. Protect the oil seal surface on the front slip yoke by taping or wiring a cloth over the complete front universal joint.

41-15 DISASSEMBLY OF PROPELLER SHAFT ASSEMBLY

For ease in handling and to help prevent damage to the constant velocity universal joint, the front and rear propeller shafts should be separated at the slip joint before any service operations are attempted.

NOTE: Never clamp propeller shaft tubing in a vise as the tube is easily dented. Always clamp on one of the yokes. Be careful not to damage the front propeller shaft slip yoke sealing surface. Any nicks can damage the bushing or cut the seal.

a. Disassembly of Slip Joint

1. Loosen locknut until free of threads and slide locknut and seal against the constant velocity joint.

2. Slide the rear propeller shaft from the front propeller shaft.

b. Removal and Disassembly of Center Bearing Assembly

1. Mount propeller shaft assembly in a vise by the yoke to keep it from turning while using the puller.

2. Place the smaller O.D. end of Adapter J-2241-8 (Differential side carrier bearing puller adapter, 1955 and previous) into the splines of the propeller shaft. Position Differential Side Bearing Puller J-2241-2 as shown in Figures 40-58 and 40-59. Pull the center support and bearing assembly from the propeller shaft. Leave the slinger (shield) in position on the shaft.

3. Remove center bearing from support as follows:

a. On 45-46-48000 Series, remove snap ring and flat washer. Remove center bearing assembly with assistance of Remover J-7273-22 and Handle J-7013-1 (Flight Pitch Tools).

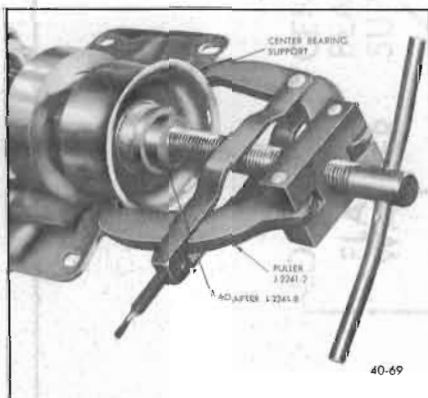

Figure 40-58—Removing Center Support and Bearing, 45-46-48000

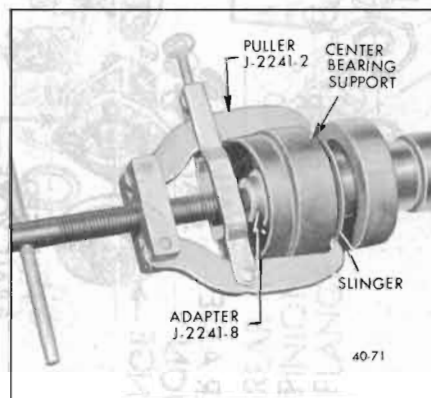

Figure 40-59—Removing Center Support and Bearing, 49000

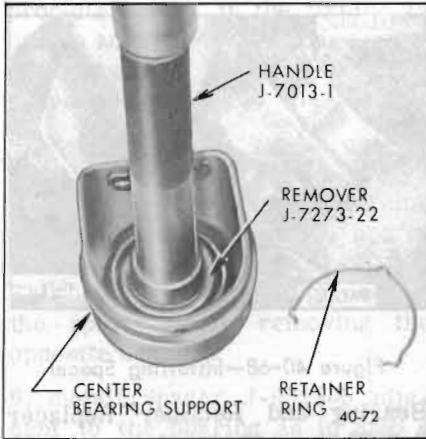

Figure 40-60—Removing Center Bearing from Support

NOTE: On 45-46-48000 Series, replacement bearing must be serviced as an assembly including bearing, rubber cushion and inner retainer. Order from Parts Department under Group 5.441.

b. On 49000, remove retainer rings from bearing assembly and remove center bearing with assistance of Remover J-7273-22 and Handle J-7013-1. See Figure 40-60.

c. Disassembly of Center (45-46-48-49000) and Rear (49000) Constant Velocity Universal Joint

All yokes must be marked before disassembly for reassembly in

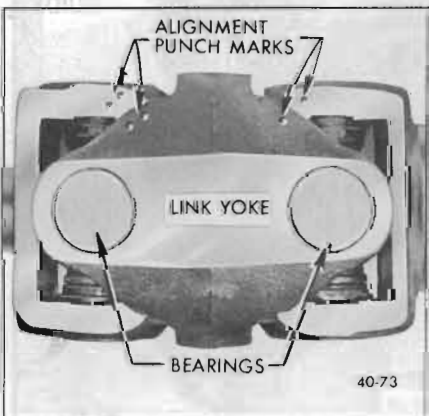

Figure 40-61—Link Yoke Showing Alignment Punch Marks

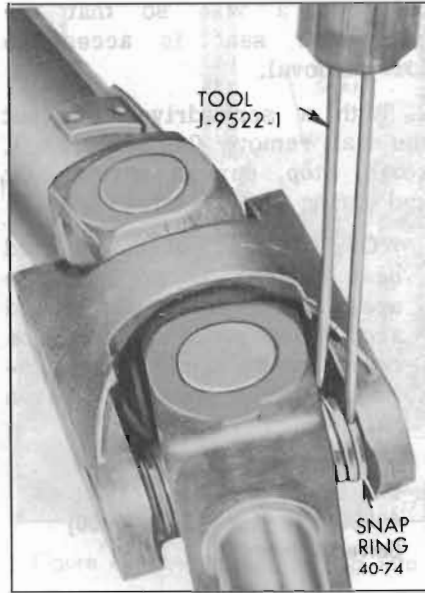

Figure 40-62—Removing Snap Rings from Propeller Shaft

their original positions to maintain proper balance. For ease of disassembly, remove the bearings from the link yoke first. See Figure 40-61.

NOTE: On 49000, the following procedure applies to either center or rear constant velocity joints.

NOTE: For ease of disassembly, remove universal joint bearings from link yoke first.

1. Remove snap rings from the bearings. The snap rings are on

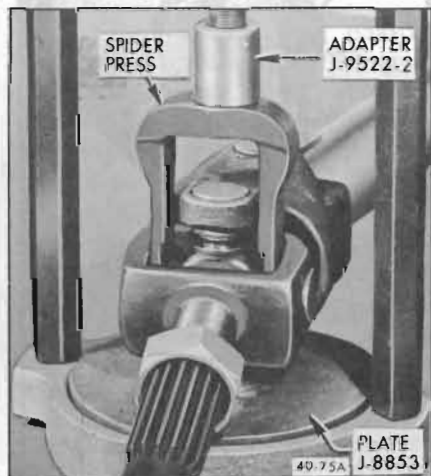

Figure 40-63—Pressing Out Bearing

the inside of the link yoke and can be removed with the assistance of Tool J-9522-1. See Figure 40-62.

2. Set up Power Ram and Hydraulic Pump in preparation for removing the propeller shaft bearings. With this use Axle Bearing and Retainer Replacer J-8853 as a base plate. Attach Adapter J-9522-2 onto the ram screw. See Figure 40-63.

3. Position propeller shaft constant velocity joint into the fixture as set up in Step 2 with the link yoke bearing over the hole in J-8853 Replacer Plate. Install Spider Press J-9522-3 on spider. See Figure 40-63. The notches in the spider press are offset so that this press can be positioned on the spider without interference from the link yoke casting. With tools in position, actuate the pump and force the spider against the lower bearing, pushing the bearing as far out of the yoke and through the hole in Tool J-8853 as possible.

4. Release the pump and rotate the propeller shaft to the opposite side. Repeat step 3. Install Spacer J-9522-5 over the spider journal in the space provided with the bearing forced partially through the link yoke. See Figure 40-64. Reposition propeller shaft in fixture as before and force the bearing completely out of the yoke with the added assistance of the Spacer.

5. Release the pump and the propeller shaft. Install Guide



Figure 40-64—Installing Spacer

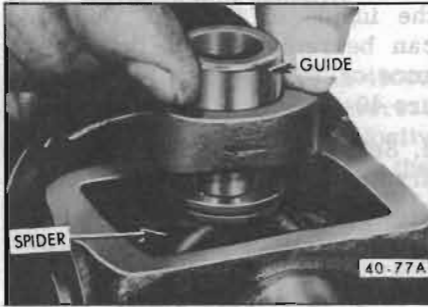

Figure 40-65—Installing Guide

J-9522-8 through the bearing hole in the link yoke and over the journal end of the spider. See Figure 40-65. This guide assures alignment of the spider while removing the opposite bearing.

6. Install Spacer J-9522-5 adjacent to the bearing as in Step 4 and remove the bearing. See Figure 40-66.

7. Carefully work universal joint and ball stud yoke assembly out of link yoke.

8. Repeat steps 3, 4, 5 and 6 to remove other bearings from ball stud yoke until the spider can be slipped out of the ball stud yoke.

d. Disassembly of Ball Stud Seat

1. Position the propeller shaft



Figure 40-66—Removing Bearing with Guide and Spacer in Place

yoke in a vise so that the ball stud seat is accessible for removal.

2. With a screwdriver pry out the seal, remove .040 spacer, ball seats, stop, spring, spring seat and spring seat gasket.

NOTE: The lip of the ball stud seat may be deformed in the area where previously staked around the seal. This can be corrected by lightly tapping deformed area with a ball peen hammer.

e. Disassembly of the Front (45-46-48-49000) and Rear (45-46-48000) Universal Joints

NOTE: Do not damage front propeller shaft slip yoke sealing surface. Any nicks can damage bushing or cut seal.

1. Remove snap rings from the bearings. The snap rings are on the inside of the yoke and can be removed with the aid of Tool J-9522-1. See Figure 40-62.

2. Set up Power Ram and Hydraulic Pump in preparation for removing the propeller shaft bearings. With this use Axle



Figure 40-67—Pressing Out U-Joint Bearing

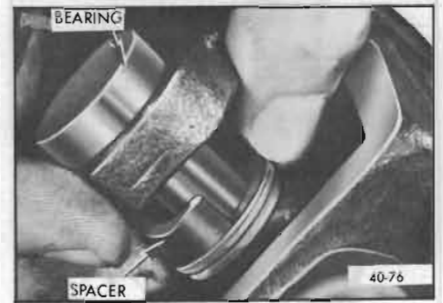

Figure 40-68—Installing Spacer

Bearing and Retainer Replacer J-8853 as a base plate. Attach Adapter J-9522-2 onto the ram screw. See Figure 40-67.

3. Position the propeller shaft universal joint into the fixture as set up in Step 2 with a bearing over the hole in Replacer J-8853. Install Spider Press J-9522-3 on spider. See Figure 40-67.

With tools in position actuate the pump and force the spider against the lower bearing, pushing the bearing as far out of the universal joint and through the hole in Tool J-8853 as possible.

4. Release the pump and remove the propeller shaft. Install Spacer J-9522-5 over the spider journal at the space provided with bearing forced partially through the yoke. See Figure 40-68. Reposition the

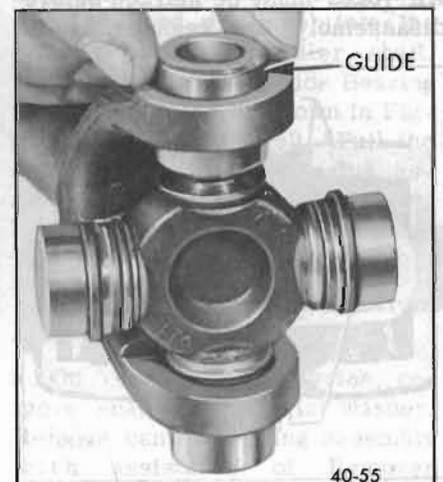

Figure 40-69—Installing Guide

propeller shaft in the fixture as before and force the bearing completely out of the yoke with the added assistance of the Spacer.

5. Release pump and propeller shaft. Install Guide J-9522-8 through the bearing hole in the yoke and over the journal end of the spider. See Figure 40-69. This guide assures alignment of the spider while removing the opposite bearing.

6. Install Spacer J-9522-5 adjacent to the bearing as in Step 4 and remove the bearing. See Figure 40-70.

7. Repeat Steps 3, 4, 5 and 6 to remove other bearings until the propeller shaft is disassembled to the point desired.

41-16 ASSEMBLY OF PROPELLER SHAFT

a. Assembly of Front (45-46-48-49000) and Rear (45-46-48000) Universal Joints

When inspection indicates any worn or damaged universal joint parts, always install a complete universal joint repair kit. Repair kits are listed in the Buick Master Parts Catalog under Group 5.442 and include a spider, four

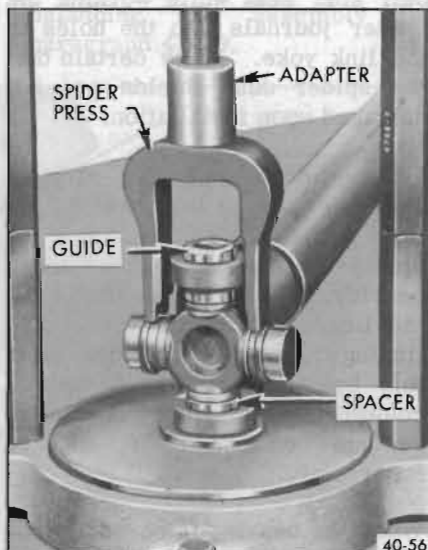

Figure 40-70—Removing Bearing with Guide and Spacer in Place

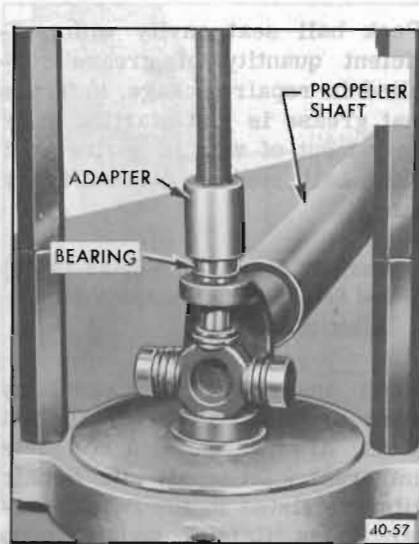

Figure 40-71—Pressing Bearing Into Place

bearings and four snap rings.

1. Position the new spider inside the yoke; it may face either direction. Make certain that the spider dust shields are not damaged upon installation.

2. Make certain that the bearings have a full set of rollers, are packed with lubricant and that the seals are in position. Multi-Purpose Universal Joint bearing grease No. 2 grade should be added to bearings if they are dry, although new bearings are normally pre-lubricated as received from the source.

Place the assembly in position with Power Ram and Pump as shown in Figure 40-71. Position the bearing straight over the hole in the yoke. Carefully pull up the spider so that the spider journal enters the loose bearing. With the pump, force the bearing into the yoke continuing to hold the spider up in this bearing. Failure to do this could cause the bearing needles to become dislodged if the journal is engaged incorrectly.

When the bearing is correctly positioned in the yoke, turn the assembly over. Again place the bearing over the hole in the yoke.

Carefully slide the spider partially out of the previously seated bearing and start it carefully into the bearing being installed. This is to prevent the needles from the bearing from burring the edge of the spider journal if forced over this journal other than straight. Even slight burring of the journal can cause premature failure. While pressing bearings into position, move the spider back and forth to make certain that the spider journals engage the bearings squarely to avoid damage and binding. If binding exists, remove the bearings and spider and examine for dislodged rollers or damaged journals.

3. Observing the previous precautions, install the balance of the bearings necessary to complete the assembly and install snap rings.

4. Strike the yoke with a hammer to fully seat the snap rings against the yoke. Turn the spider to make certain that it is free. See Figure 40-72.

b. Assembly of the Ball Stud Seat

Examine the ball stud and ball stud seats for scores or wear. Worn seats can be replaced by using a replacement kit, Group 5.442. Since the ball stud is an integral part of the splined yoke, any scoring of this part requires the replacement of this splined



Figure 40-72—Seating U-Joint Snap Rings

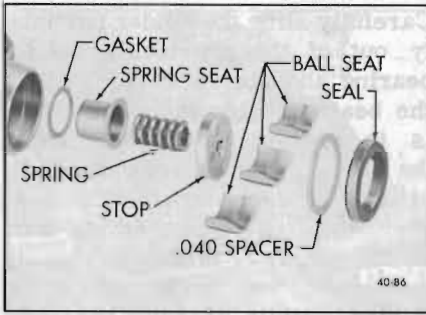

Figure 40-73—Ball Seat Assembly

yoke. This assembly is also available in kit form, Group 5.442.

1. Thoroughly clean ball seat cavity.

2. Install spring seat gasket, spring seat and spring. Pack spring seat with grease supplied in repair package (Multi-Purpose Grease, EP No. 1 Grade). Install stop, ball stud seats and .040" spacer. Apply a thin coat of non-hardening sealer such as number 2 Permatex or equivalent to the outer diameter of the seal to insure adequate sealing and install seal with lip toward the seat using Tool J-22271. See Figure 50-74.

3. Stake the seal lightly and evenly in four places, in same area as previously staked. Be careful not to overstake so as to damage or distort the seal.



Figure 40-74—Installing Ball Seat Seal

Pack ball seat cavity with sufficient quantity of grease supplied in repair package, to insure that grease is just starting to be forced out of vent in spring seat when ball stud is pushed in by hand.

c. Assembly of Center (45-46-48-49000) and Rear (49000) Constant Velocity Universal Joints

When inspection indicates any worn or damaged universal joint parts, always install a complete universal joint repair kit. Repair kits are listed in the Buick Master Parts Catalog under Group 5.442 and include a spider, four bearings and four snap rings.

1. Position the spider inside the ball stud yoke; due to production tolerances, it may fit easier facing one direction than the other. Make certain that the spider dust shields are not damaged during installation.

2. Make certain that the bearings have a full set of rollers, are packed with lubricant and that the seals are in position.

Place the assembly in position with Power Ram and Pump. Position the bearing straight over the hole in the yoke. See Figure 40-75. Carefully pull the spider up so that the spider journal enters the loose bearing. With the pump, force the bearing into the yoke continuing to hold the spider up in this bearing. Failure to do this could cause the bearing needles to become dislodged if the journal is engaged incorrectly. When the bearing is correctly positioned in the yoke, turn the assembly over. Again place the bearing over the hole in the yoke. Carefully slide the spider partially out of the previously seated bearing and start it carefully into the bearing being installed. This is to prevent the needles in the bearing from burring the edge of the spider journal if forced over this journal other than straight.

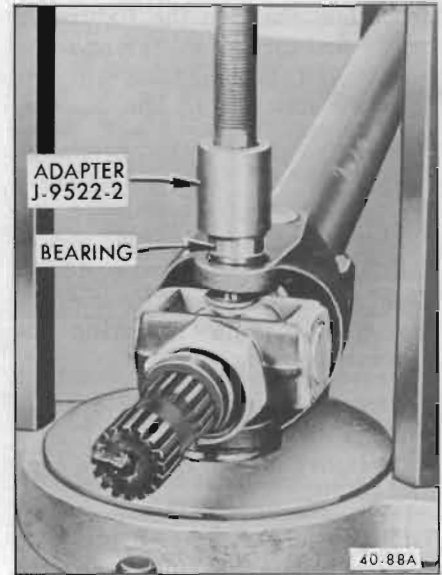

Figure 40-75—Pressing Bearing Into Position

Even slight burring of the journal can cause premature failure. While pressing bearings into position, move the spider back and forth to make certain that the spider journals engage the bearings squarely to avoid damage and binding. If binding exists remove the bearings and spider and examine for dislodged rollers or damaged journals.

3. Position the ball stud into the ball stud seat while working the spider journals into the holes in the link yoke. Make certain that the spider dust shields are not damaged upon installation.

4. Position the bearing straight over the hole in the yoke. Carefully pull up the spider so that the spider journal enters the loose bearing. With the pump, force the bearing into the yoke, continuing to hold the spider up in this bearing. Failure to do this could cause the bearing needles to become dislodged if engaged incorrectly.

When the bearing is correctly positioned in the yoke, turn the assembly over. Again place the bearing over the hole in the yoke.

Carefully slide the spider partially out of the previously seated bearing and start it carefully into the bearing being installed. This is to prevent the needles in the bearing from burring the edge of the spider journal if forced over journal other than straight. Even slight burring of the journal can cause premature failure. While pressing bearings into position, move the spider back and forth to make certain that the spider journals engage the bearings squarely to avoid damage and binding. If any binding exists, remove the bearings and spider and examine for dislodged rollers or damaged journals.

5. Install the balance of the bearings necessary to complete the assembly and install snap rings.

6. Strike the yoke with a hammer to fully seat the snap rings against the yoke. Turn the spider to make certain that it is free. See Figure 40-76.

NOTE: If a new splined yoke or flange yoke (49000) assembly was used, the car should be carefully roadtested for possible vibration caused by out-of-balance propeller shaft. If propeller shaft vibration is encountered see the procedure for balancing this assembly in paragraph 41-20.



Figure 40-76—Seating U-Joint Snap Rings

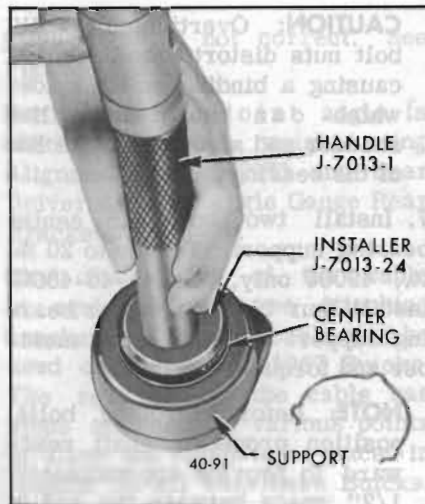

Figure 40-77—Installing Center Bearing Into Support

d. Installation of Center Bearings

1. On 49000 Series, install new bearing into center bearing support with the aid of Installer J-7013-24 and Handle J-7013-1 (Flight Pitch Tools). See Figure 40-77.

NOTE: On 45-46-48000 Series, bearing must be serviced as an assembly including bearing, rubber cushion and inner retainer. Install bearing and related parts into cup-shaped support as in preceding step.

2. On 49000 install retainer ring to secure bearing. On 45-46-48000 install flat washer and retainer ring.

3. On 49000 make certain that the slinger is in place on the propeller shaft. Install the center bearing support assembly onto the propeller shaft with Installer J-21007. On 45-46-48000 make certain that slinger is in place and then install flat washer on shaft. With slinger and washer in place, install center bearing assembly using Installer J-21007.

e. Assembly of Slip Joint

1. Make certain that the locknut, split washer and seal are in place on the smooth part of the spline shaft. Make certain that the index spring wire is in place in the splines.

2. Align the index spring with the missing internal spline in the rear end of the front propeller shaft and slide the slip joint together. See Figure 40-78 for proper phasing of the propeller shaft.

3. Install the locknut and tighten securely to 65 lb. ft. using locknut Wrench J-21009.

41-17 INSTALLATION OF PROPELLER SHAFT

The propeller shaft must be supported carefully during handling to avoid jamming or bending any of the parts.

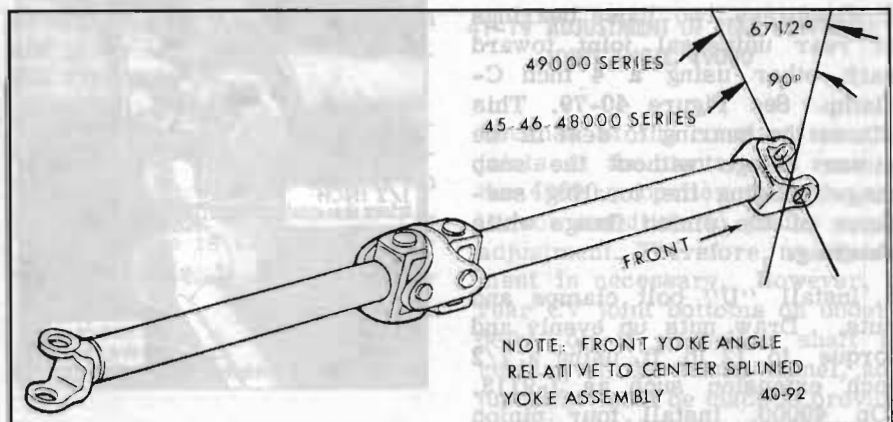

Figure 40-78—Propeller Shaft Phasing

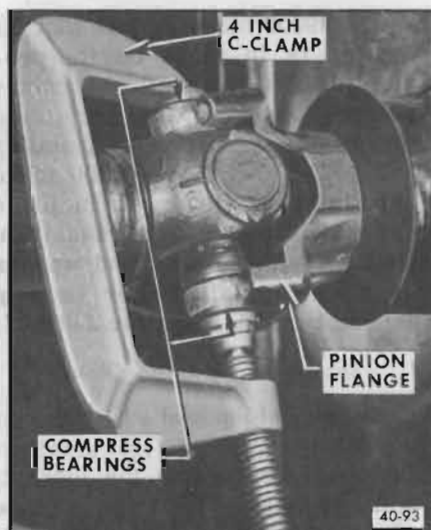

Figure 40-79—Using C-Clamp to Install U-Joint

1. Protect the oil seal diameter on the front slip yoke by taping or wiring a cloth over the complete front universal joint.

2. Slide complete propeller shaft assembly forward (through frame tunnel, 49000).

3. Remove protecting cover from front universal joint. Fill space between lips of transmission seal with wheel bearing grease and apply a thin coat of the same grease to the seal surface of the front universal joint.

4. Slide front universal joint yoke forward over splines of transmission shaft.

5. Compress two loose bearings of rear universal joint toward each other using a 4 inch C-clamp. See Figure 40-79. This allows the bearing to seat in the pinion flange without the snap rings gouging the locating surfaces of the pinion flange while entering.

6. Install "U" bolt clamps and nuts. Draw nuts up evenly and torque to 12 lb. ft. using a 1/2 inch extension such as J-9113. (On 49000, install four pinion flange bolts and torque evenly to 85 lb. ft.). See Figure 40-80.

CAUTION: Overtightening "U" bolt nuts distorts the bearings, causing a binding on the spider which can cause drive line shudder and also reduce the life of the bearings and spider.

7. Install two bolts in center bearing support. Torque to 20 lb. ft., 49000 only. On 45-46-48000 install four bolts at center bearing support to frame cross member and torque to 20 lb. ft.

NOTE: Before torquing bolts, position propeller shaft rearward to provide approximately 1/2" space between the end of the transmission case extension and the shoulder of the propeller shaft slip yoke.

8. Make certain propeller shaft slip spline and center ball stud seat are fully lubricated with Multi-Purpose Grease EP No. 1 Grade.

41-18 ADJUSTMENT OF REAR UNIVERSAL JOINT ANGLE 45-46-48000

When torque is transmitted through any ordinary universal joint, the driven yoke fluctuates slightly in speed. In other words, although the driving yoke rotates at a constant speed, the driven

yoke speeds-up and slows-down twice per revolution. This fluctuation of the driven yoke is in direct proportion to the angle through which the universal joint is operating; the greater the angle, the greater the fluctuation. Whenever two universal joints are used, this fluctuation effect can be eliminated by staggering the joints so that the two driving yokes are 90° apart providing the two joints are transmitting torque through the same angle.

Therefore, when two universal joints are used, the angles through which they operate must be very nearly the same. This allows the alternate acceleration and deceleration of one joint to be offset by the alternate deceleration and acceleration of the second joint. When the two joints do not run at approximately the same angle, operation is rough and an objectionable vibration is produced.

The actual optimum angles desired must also consider the effects of various passenger loadings and rear axle windup during acceleration so that it is unlikely that the front and rear joints will be found to be the same in actual practice.

In addition, universal joints are designed to operate safely and efficiently within certain angles. If the designed angle is exceeded, the joint may be broken or otherwise damaged.

The front universal joint angle is actually the angle between the engine-transmission centerline and the front propeller shaft. This angle is determined by the design of the body assembly. Since this angle is not liable to change with use, there is normally no need to change this angle. The center constant velocity universal joint, just as the name implies, transmits at a constant velocity regardless of the

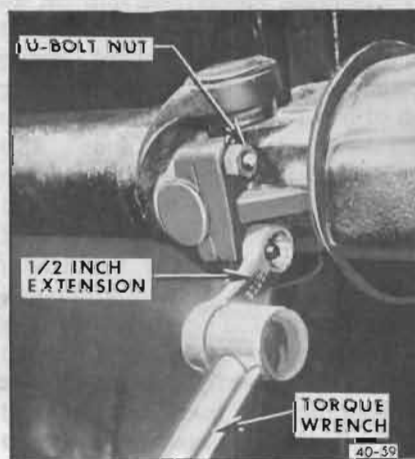

Figure 40-80—Using Extension to Torque U-Bolt Nuts

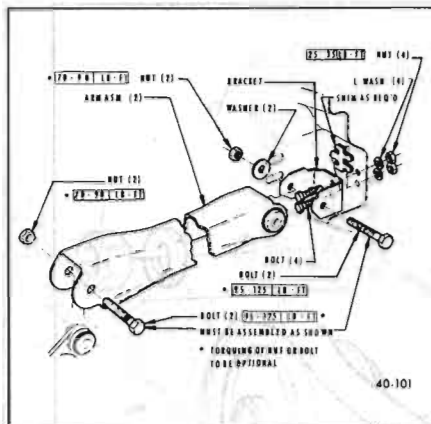

Figure 40-81—Shimming Upper Control Arm

angle through which it is operating. Therefore, no means is provided or needed for adjusting the constant velocity joint.

However, the rear universal joint angle can vary and must be adjusted. It is adjusted by rotating the rear axle housing; this is accomplished by lengthening or shortening the upper control arms by means of shimming at the frame bracket ends. See Figure 40-81.

If drive line shudder, roughness, vibration or rumble is experienced, it may be due to incorrect rear universal joint angle and this angle should be checked. Also if there is a severe rear end collision, or if the axle housing or any control arms are replaced, the rear universal joint angle should be checked and corrected if necessary.

A simple method has been developed for measuring rear universal joint angle using a spring-loaded steel cable stretched between the front of the chassis and the differential carrier. When the rear universal joint angle is adjusted correctly, this steel cable will clear the underside of the pinion flange by a definite amount. Therefore, if this single direct measurement is within specified limits, the rear universal joint angle is correct; if this measurement is out of limits, the

joint angle is not correct. See Figure 40-82.

Rear universal joint angle is checked at curb weight using Alignment Set J-8973 and Rear Universal Joint Angle Gauge Rear Bracket J-8973-35.

The front end of the cable is equipped with two attaching brackets so that the cable may be used on all series 1967 Buicks. The rear end of the cable has stops attached at various points to allow the cable to be placed in tension on all wheelbase Buicks.

a. Checking Rear Universal Joint Angle

Check rear universal joint angle using the following procedure:

1. Raise car, preferably on a drive-on hoist.
2. Remove differential cover bolt on either side of lowest cover bolt. Using two 5/16-18 x 1-1/8" bolts with 3/8" spacers, attach rear bracket J-8973-35.
3. Take cable assembly and hook Front Attaching Bracket J-8973-15 over center of front frame cross member. Pull cable tight and position cable all-the-way in slot of rear bracket so one of the stops is to the rear of the bracket.
4. Position Engine Height Plate J-8973-14 vertically with wide end centered against rear flange of engine pan. Pull cable down and place in lower notch of plate. See Figure 40-82.
5. Measure perpendicular distance from machined surface immediately in front of slinger on rear pinion flange to top of cable. This distance is given for 45-46-48000 models in Figure 40-82.

b. Adjusting Rear Universal Joint Angle

If the distance measured in Step 5 above was not correct, the pinion nose must be moved up or

down as required. This is done by shimming the upper control arms.

Adjust rear universal joint angle using the following procedure:

1. Place a jack under pinion nose. Because of the geometry of the rear suspension, the pinion nose will tend to move downward when released and must be held upward.
2. Loosen nuts and bolts retaining upper control arm brackets to frame. See Figure 40-81.
3. Using jack, raise or lower pinion nose as required to get correct measurement from pinion flange to top of cable.
4. Install shims as required between brackets and frame.
5. Lower jack from under pinion nose and retorque bracket to frame attaching nuts and bolts to 30 lb. ft. Recheck measurement on Kent-Moore set-up. If dimension is off, loosen bracket to frame nuts and bolts and repeat preceding steps to obtain correct reading.
6. Remove all parts of the alignment set, being careful to avoid kinking cable in handling and storing.
7. Reinstall differential cover bolts and torque to 30 lb. ft.

41-19 ADJUSTMENT OF REAR UNIVERSAL JOINT ANGLE, 49000

Because of the constant velocity joints at the center and rear of the 49000 propeller shaft, the car is not sensitive to pinion angle adjustment. Therefore, no adjustment is necessary. However, if rear CV joint bottoms on underbody, or if propeller shaft is rubbing on the frame tunnel, adjustment must be made to provide sufficient clearance. Adjustment can be made using tools and procedure as described in preceding

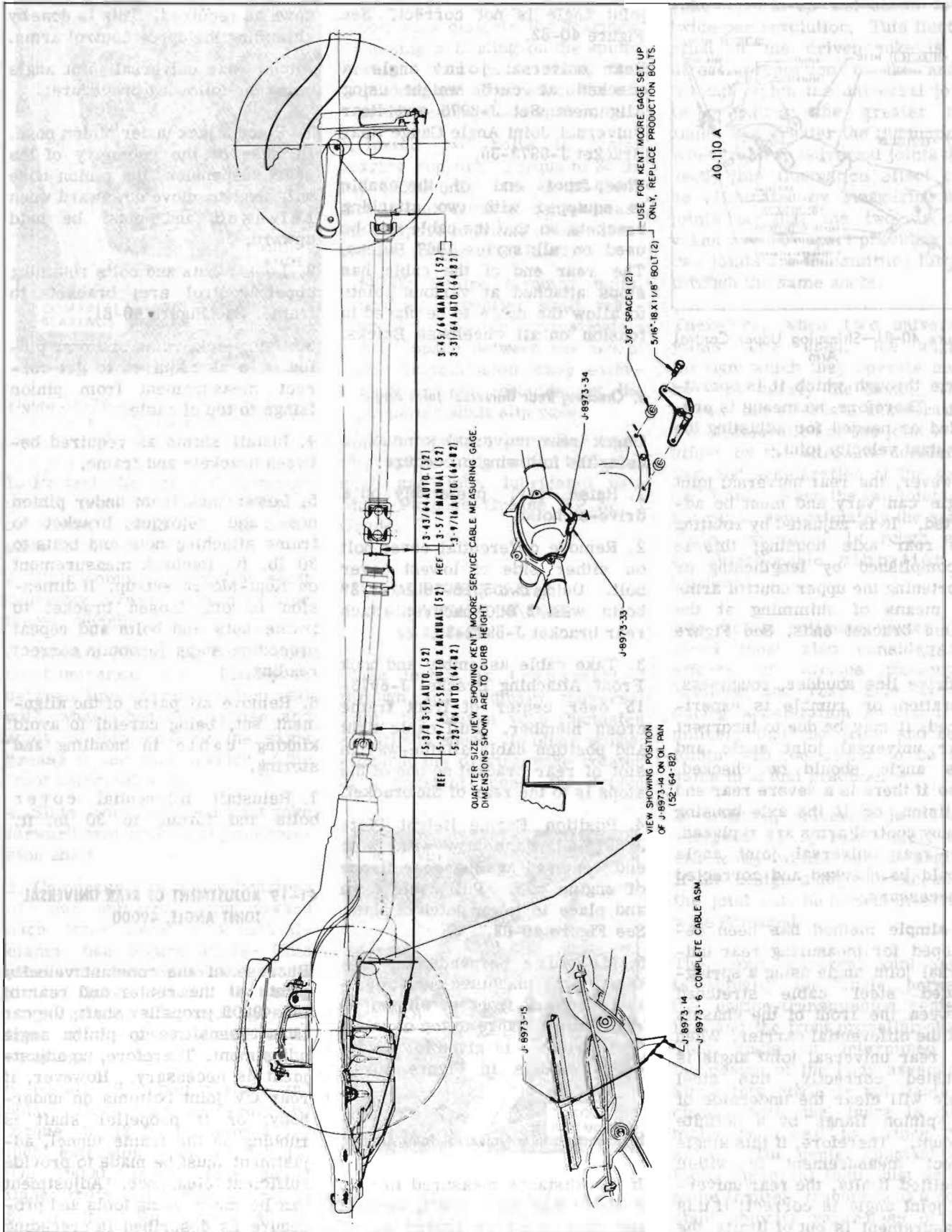

Figure 40-82—Checking Rear Universal Joint Angle, 45-46-48000

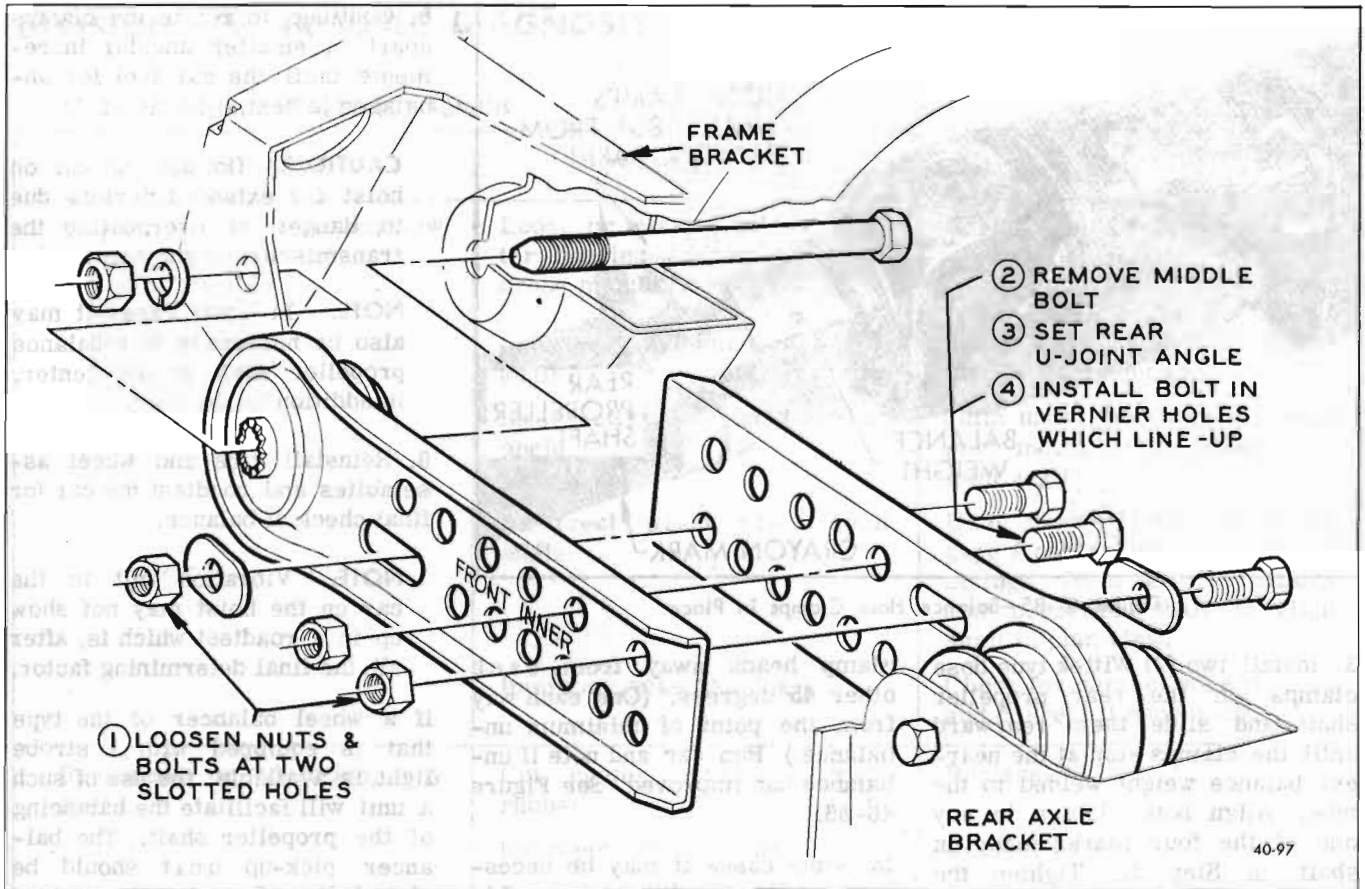

Figure 40-83—Adjusting Rear Universal Joint Angle, 49000

paragraph differing only in adjustment of vernier upper control arm. Adjust vernier arm as shown in Figure 40-83.

41-20 PROPELLER SHAFT BALANCING PROCEDURE

1. Place the car on a twin post hoist so that the rear of the car is supported on the rear axle housing and the rear wheels are free to rotate. Remove both rear tire and wheel assemblies and re-install wheel lug nuts with flat side next to drum.

2. Mark and number propeller shaft at four (4) points 90 degrees apart at rear of shaft just forward of balance weight.

NOTE: On 49000 only, to provide an access hole in the frame tunnel for inserting a screwdriver to tighten the hose

clamps, drill a 5/16" hole located as follows:

Measure from the rear of the frame tunnel forward to the first welded-on balance weight. Subtract 1/2" from this measurement; then using this distance, measure from the rear

of the frame tunnel forward and mark this distance on the bottom outside frame tunnel. This locates the hole between the clamp screws so both can be reached. Offset the hole approximately 1-1/4" from the car centerline and drill the 5/16" hole. See Figure 40-84.

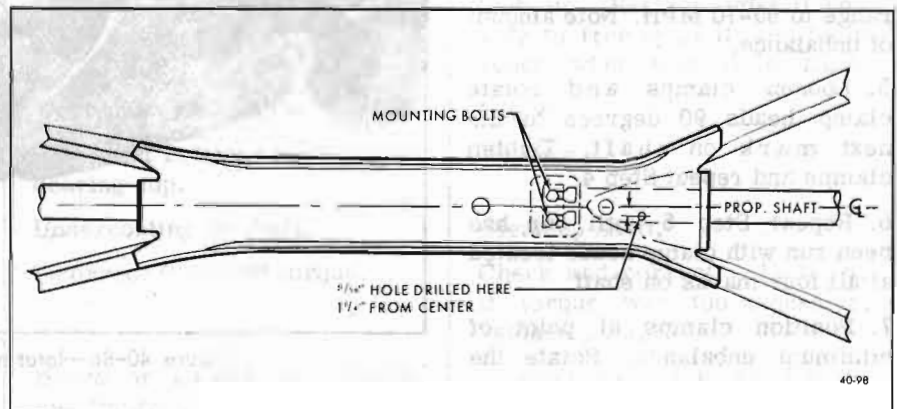

Figure 40-84—Locating Access Hole in Frame, 49000

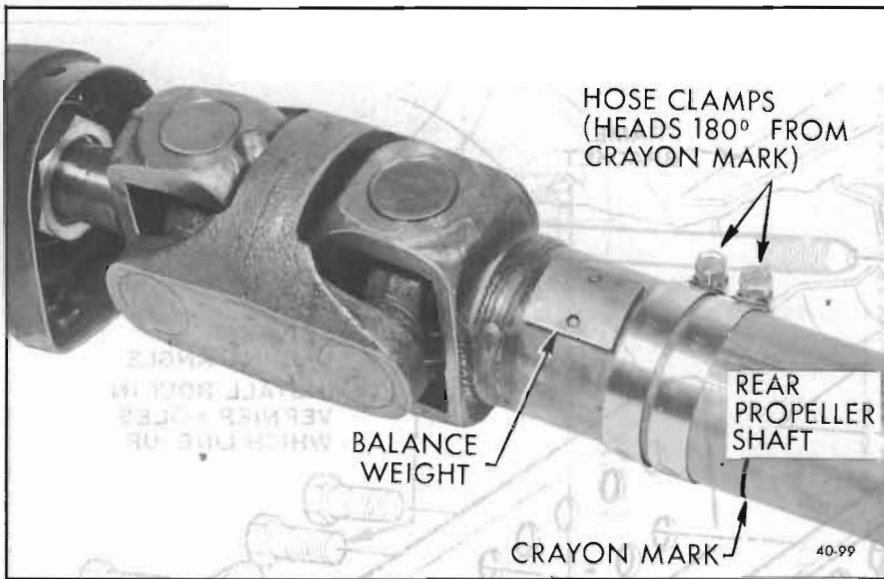

Figure 40-85—Balance Hose Clamps in Place

3. Install two (2) Wittek type hose clamps on the rear propeller shaft and slide them rearward until the clamps stop at the nearest balance weight welded to the tube. Align both clamps to any one of the four marks made on shaft in Step 2. Tighten the clamps. See Figure 40-85.

CAUTION: Be sure sufficient clearance is maintained so that clamp heads do not contact floorpan of car when axle is in contact with rebound bumper in frame. In order to gain sufficient clearance, it may be necessary to position the clamps over the balance weights.

4. Run the car through the speed range to 65-70 MPH. Note amount of unbalance.

5. Loosen clamps and rotate clamp heads 90 degrees to the next mark on shaft. Tighten clamps and repeat Step 4.

6. Repeat Step 5 until car has been run with clamp heads located at all four marks on shaft.

7. Position clamps at point of minimum unbalance. Rotate the

clamp heads away from each other 45 degrees. (One each way from the point of minimum unbalance.) Run car and note if unbalance has improved. See Figure 40-86.

In some cases it may be necessary to use one clamp or possibly three clamps in order to obtain a good balance.

8. Continue to rotate the clamps apart in smaller angular increments until the car feel for unbalance is best.

CAUTION: Do not run car on hoist for extended periods due to danger of overheating the transmission or engine.

NOTE: In some cases it may also be necessary to rebalance propeller shaft at the center, in addition to the rear.

9. Reinstall tire and wheel assemblies and roadtest the car for final check of balance.

NOTE: Vibration felt in the car on the hoist may not show up in a roadtest which is, after all, the final determining factor.

If a wheel balancer of the type that is equipped with a strobe light is available, the use of such a unit will facilitate the balancing of the propeller shaft. The balancer pick-up unit should be placed directly under the nose of the rear axle carrier and as far forward as possible.

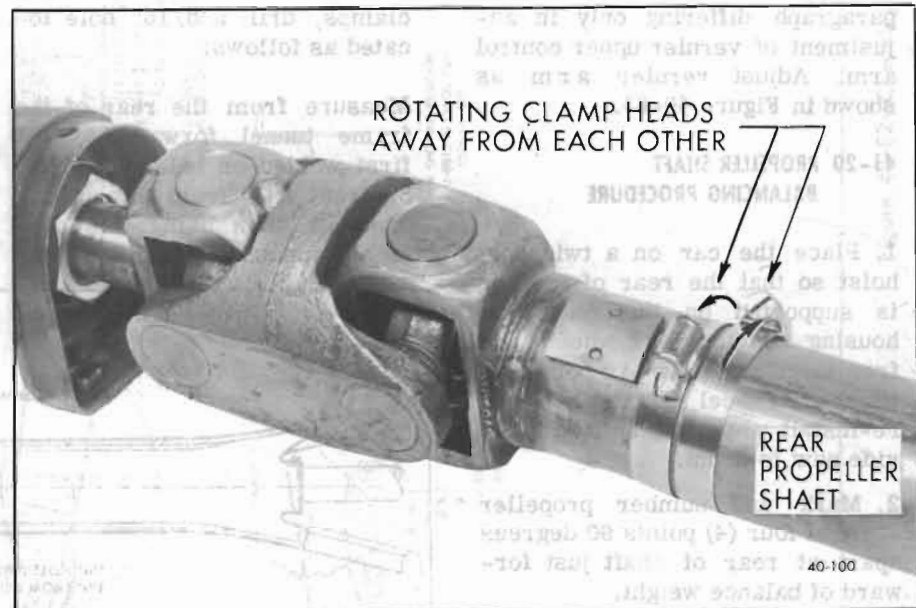

Figure 40-86—Rotating Balance Hose Clamps

DIVISION IV TROUBLE DIAGNOSIS

(5/76) 41-21 PROPELLER SHAFT TROUBLE DIAGNOSIS (Cont'd)

41-21 PROPELLER SHAFT TROUBLE DIAGNOSIS

COMPLAINT	POSSIBLE CAUSE	REMEDY
<p>Shudder on acceleration, low speed.</p>	<p>Loose or missing bolts at center bearing support to frame cross member.</p> <p>Improperly adjusted rear joint angle.</p> <p>Incorrectly set front joint angle.</p> <p>Incorrect plan view joint angle.</p> <p>Improper yoke phasing.</p>	<p>Replace or tighten bolts.</p> <p>Check and adjust using Kent-Moore alignment gage.</p> <p>Shim under transmission support mount to decrease front joint angle.</p> <p>Use Kent-Moore alignment gage cable and weighted strings from engine pulleys and propeller shaft to align shaft in plan view.</p> <p>Check for correct yoke phasing and correct if necessary.</p>
<p>Roughness or vibration, any speed.</p>	<p>Cut center bearing support rubber.</p> <p>Improper yoke phasing.</p> <p>Bent shaft.</p> <p>Dented shaft.</p>	<p>Replace.</p> <p>Correct as above.</p> <p>Replace.</p>
<p></p>	<p>Improperly aligned support.</p>	<p>Replace - On 49000 check to see if sufficient clearance exists between rear frame tunnel and propeller shaft if car is raised on a frame hoist. Grind out frame for sufficient clearance if necessary.</p>
<p></p>	<p>Tight universal joints.</p>	<p>Align or check for proper installation of mountings.</p> <p>Impact yokes with hammer to free up. Replace joint if unable to free up or if joint feels rough when rotated by hand.</p>
<p></p>	<p>Worn universal joints</p>	<p>Replace.</p>
<p></p>	<p>"U" joint retainer bent against bearing cup.</p>	<p>Replace.</p>
<p></p>	<p>Undercoating on shaft.</p> <p>Incorrect "U" bolt torque.</p>	<p>Clean up shaft.</p> <p>Check and correct - 12 lb. ft. if torque was too excessive, replace joint.</p>
<p></p>	<p>Burrs or gouges on companion flange snap ring location surfaces.</p>	<p>Attempt to clean up flange. Replace companion flange if necessary.</p>

41-21 PROPELLER SHAFT TROUBLE DIAGNOSIS (Cont'd)

COMPLAINT	POSSIBLE CAUSE	REMEDY
Roughness or vibration (Cont'd)	<p>Incorrect rear joint angle (usually too large an angle).</p> <p>Tire unbalance.</p> <p>Shaft or companion flange unbalance combination.</p> <p>Rubber center bearing mount at frame too tight.</p>	<p>Check and adjust using Kent-Moore alignment gage.</p> <p>Balance wheel and tire assembly or replace from known good car.</p> <ol style="list-style-type: none"> 1. Check for missing balance weights. 2. Remove and reassemble shaft to companion flange 180° from initial location. 3. Remove and replace companion flange at rear axle pinion 180° from initial location. 4. Rebalance. <p>Reduce "squeeze" of bracket to rubber block to .010"-.025".</p>
Roughness on heavy acceleration (short duration).	<p>CV joint ball seats worn.</p> <p>Seat spring bent or broken.</p>	<p>Replace with ball seat repair kit.</p> <p>Replace with ball seat repair kit.</p>
Roughness usually at low speeds, light load, 15-35 MPH.	Improperly adjusted joint angle.	Check and adjust rear joint angle, decrease front angle by shimming transmission support.
Whine or whistle.	Center support bearing.	Place car on hoist with rear wheels free to rotate and diagnose for source of noise. Replace center support bearing if found to be noisy.
Squeak.	Lack of lubricant or worn CV joint centering ball.	<ol style="list-style-type: none"> 1. Lube. 2. Replace with ball seat kit if lube does not correct.
Knock or click.	<p>Joint hitting frame tunnel, 49000 only.</p> <p>Worn CV joint centering ball.</p> <p>Loose upper or lower control arm bushing bolts.</p> <p>Broken or cut center bearing support rubber.</p> <p>Stones - gravel in frame tunnel, 49000 only.</p>	<p>Shim up or replace center bearing mount.</p> <p>Replace with splined yoke or ball seat replacement kit.</p> <p>Tighten bolts.</p> <p>Replace center bearing support.</p> <p>Remove stones and gravel.</p>

