

* RADIO CARS ONLY

Figure 120-154—Special Wiring Circuit Diagram

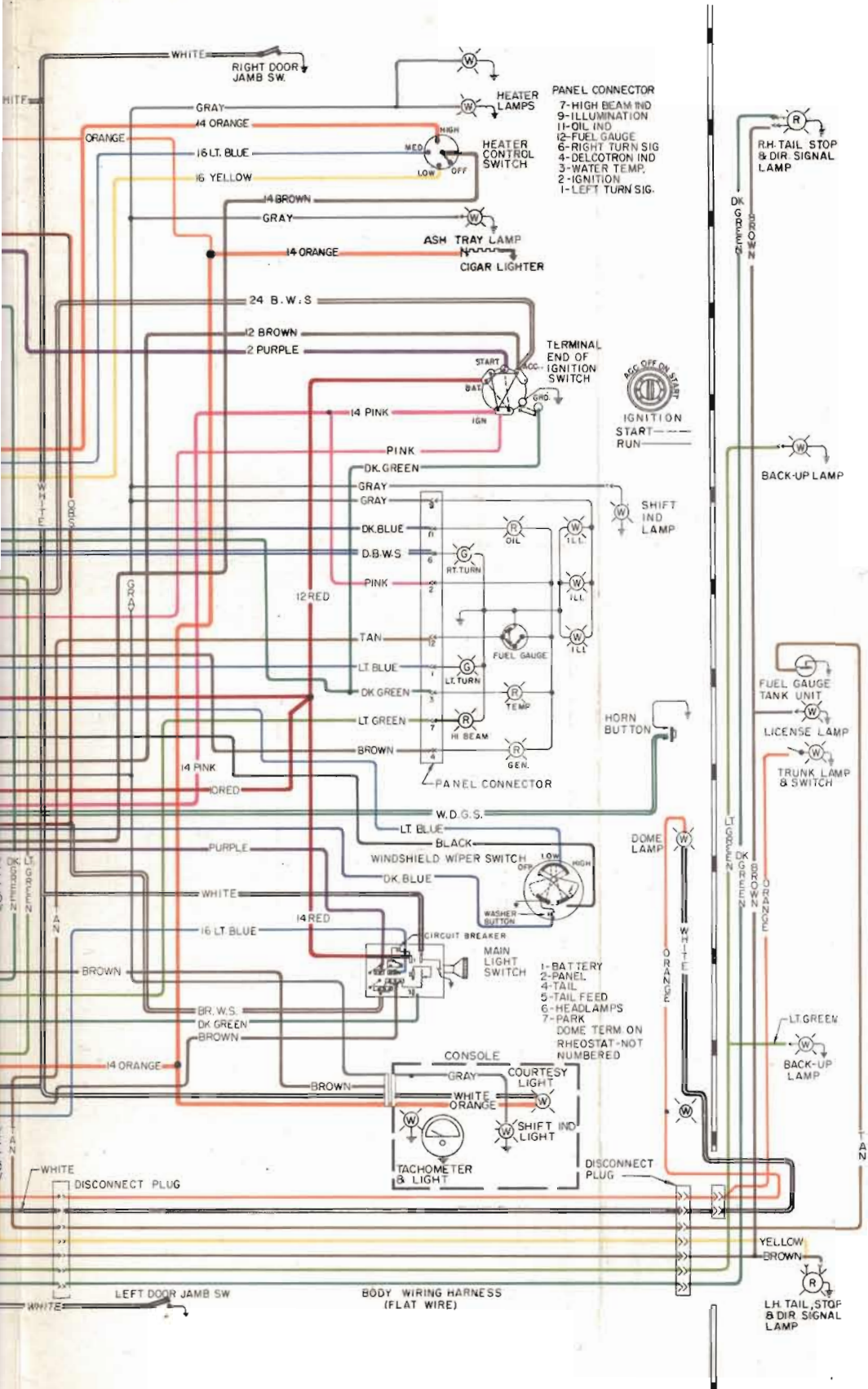

UNLESS OTHERWISE SPECIFIED ALL WIRES ARE 18 GAGE
 LETTER IN LAMP DENOTES COLOR
 WIRE COLOR CODE
 W.D.P.C.T. - WHITE WITH ORANGE & PURPLE CROSS TRACER (RES. WIRE 1.8 OHMS)
 W.D.G.S. - WHITE WITH DOUBLE DK. GREEN STRIPES
 BR. W.S. - BROWN WITH DOUBLE WHITE STRIPES
 O.B.S. - ORANGE WITH DOUBLE BLACK STRIPES
 B.W.S. - BROWN/ SINGLE WHITE STRIPE RESISTANCE (10 Ω)

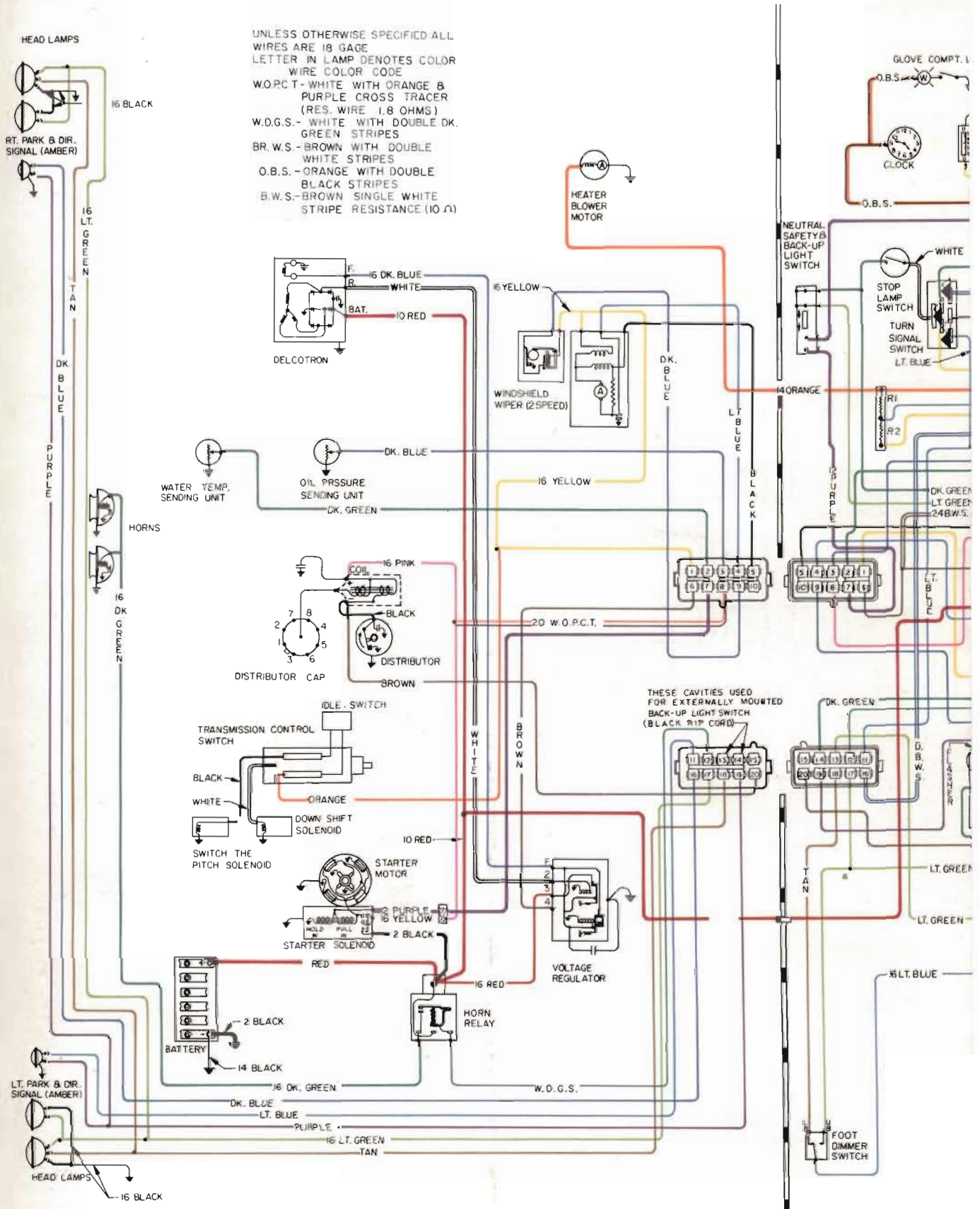
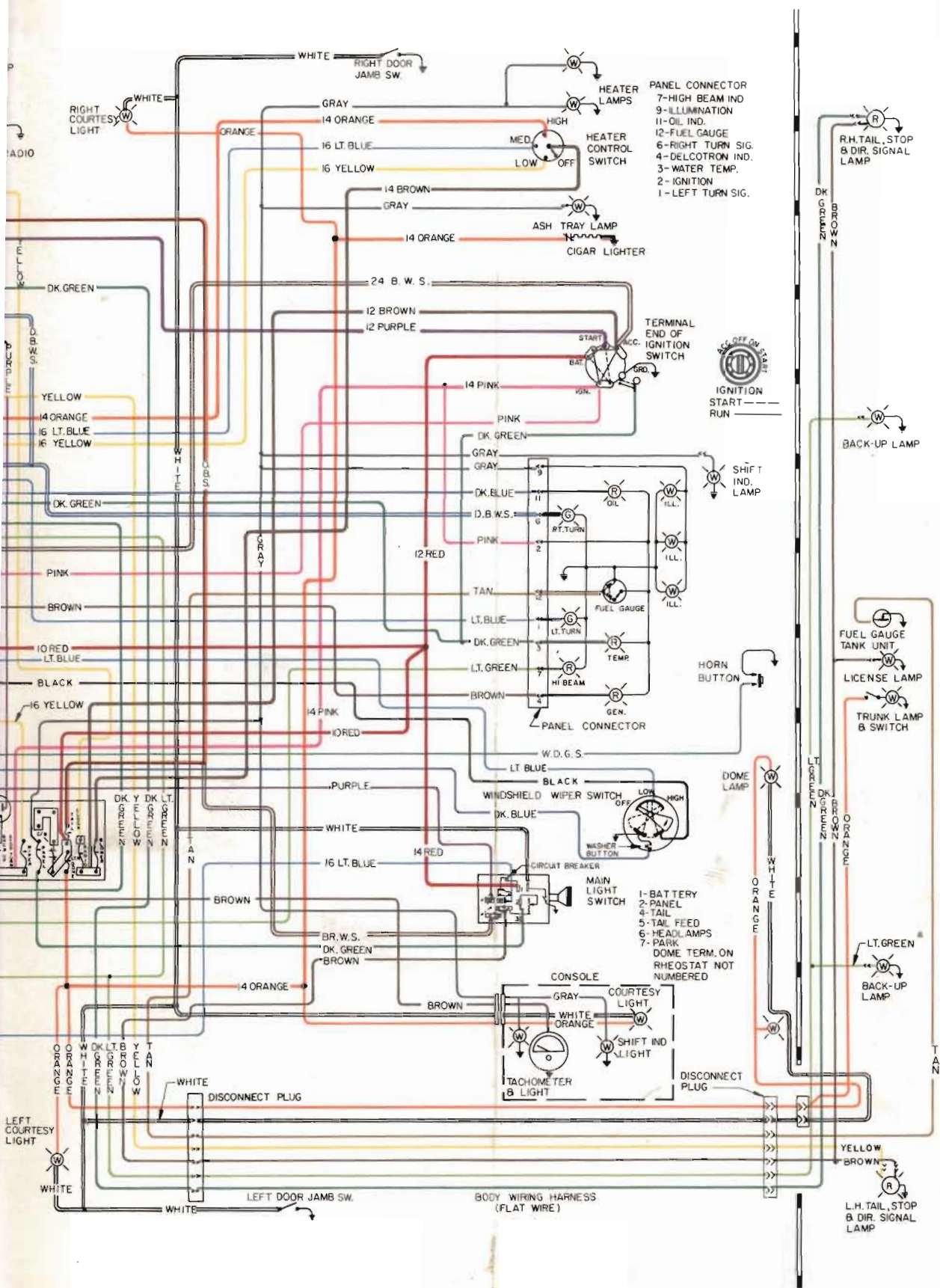

Figure 120-155—Skylark Gran Sport Wiring Circuit Diagram



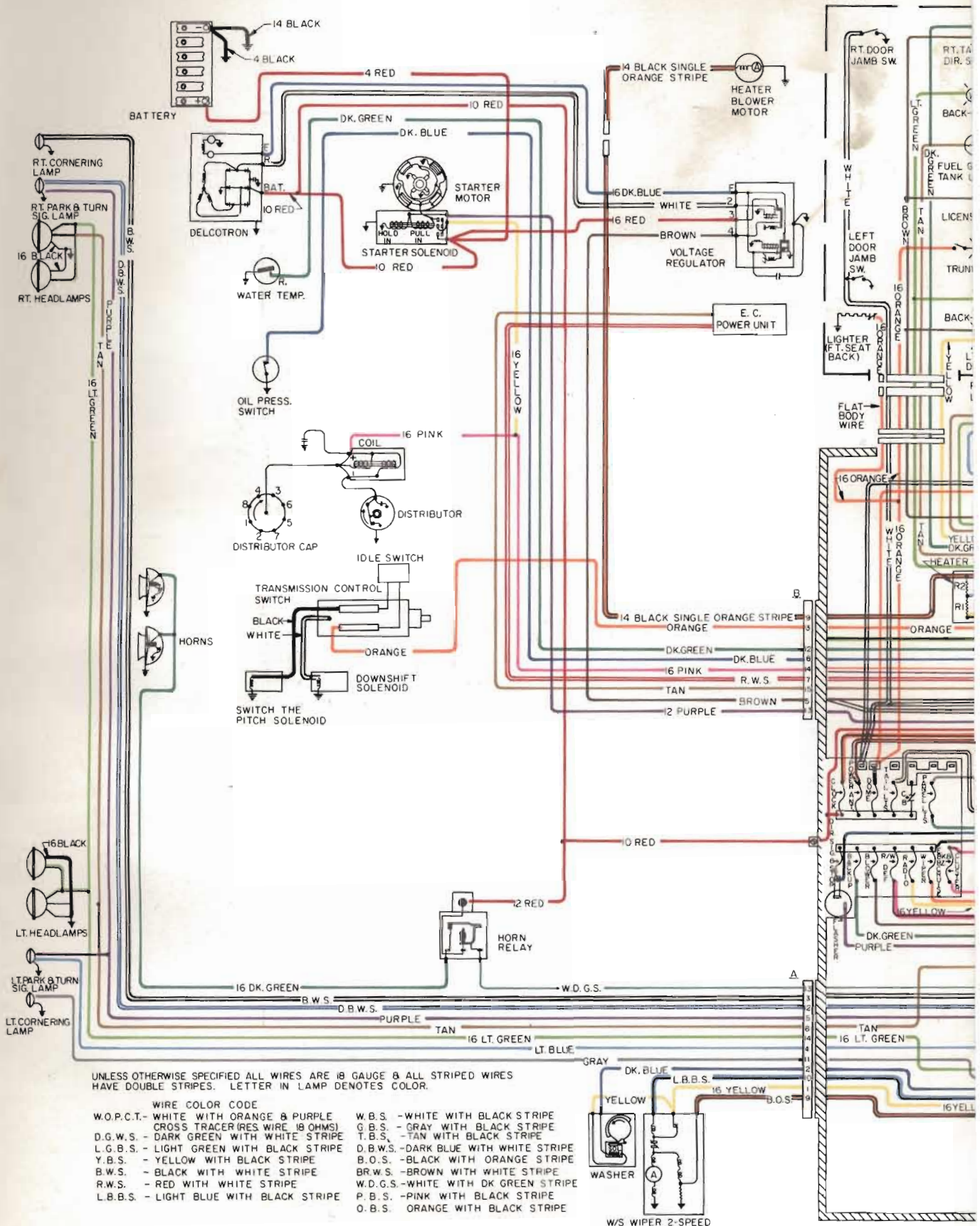
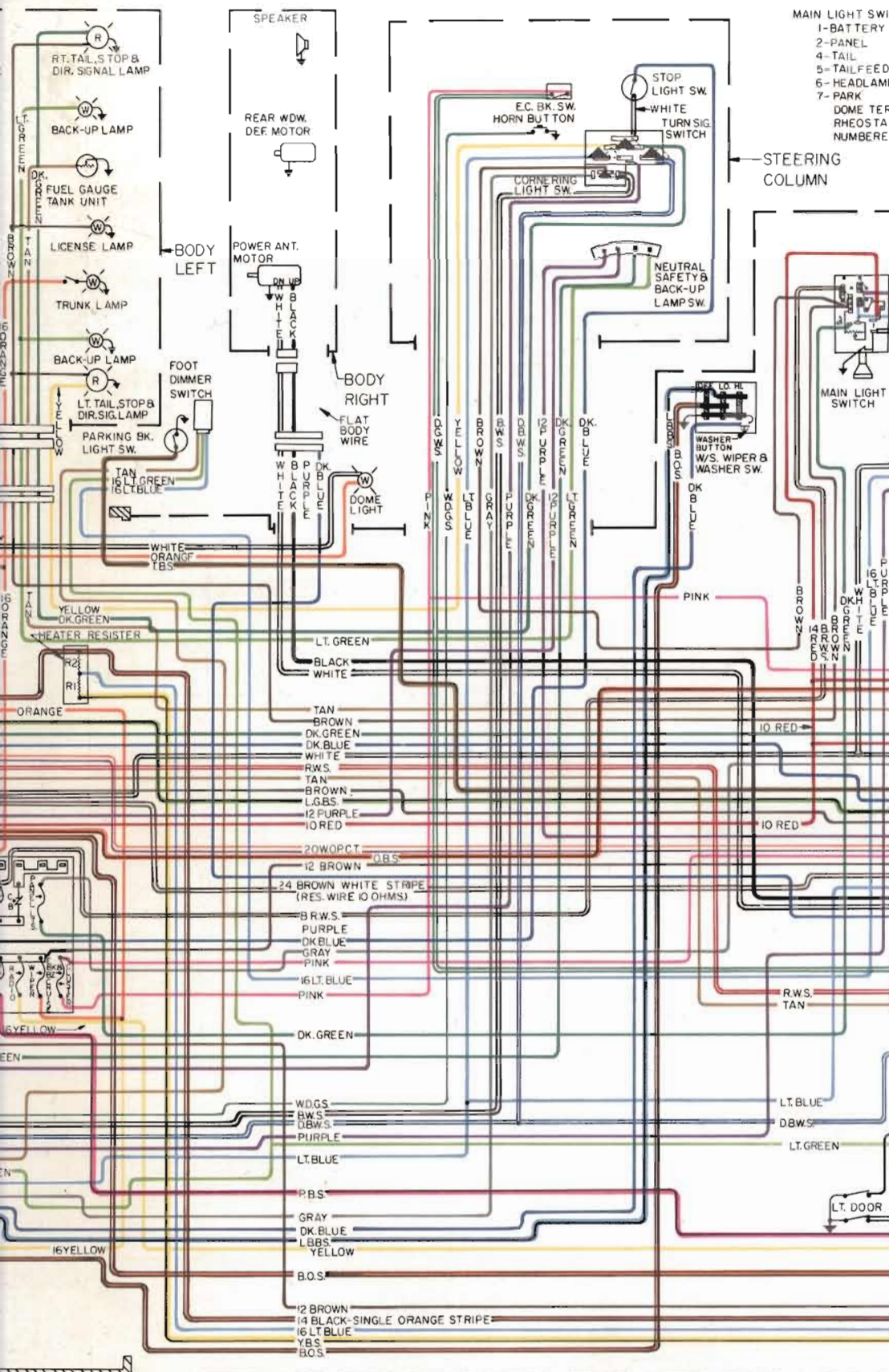

Figure 120-156—LeSabre Wiring Circuit Diagram



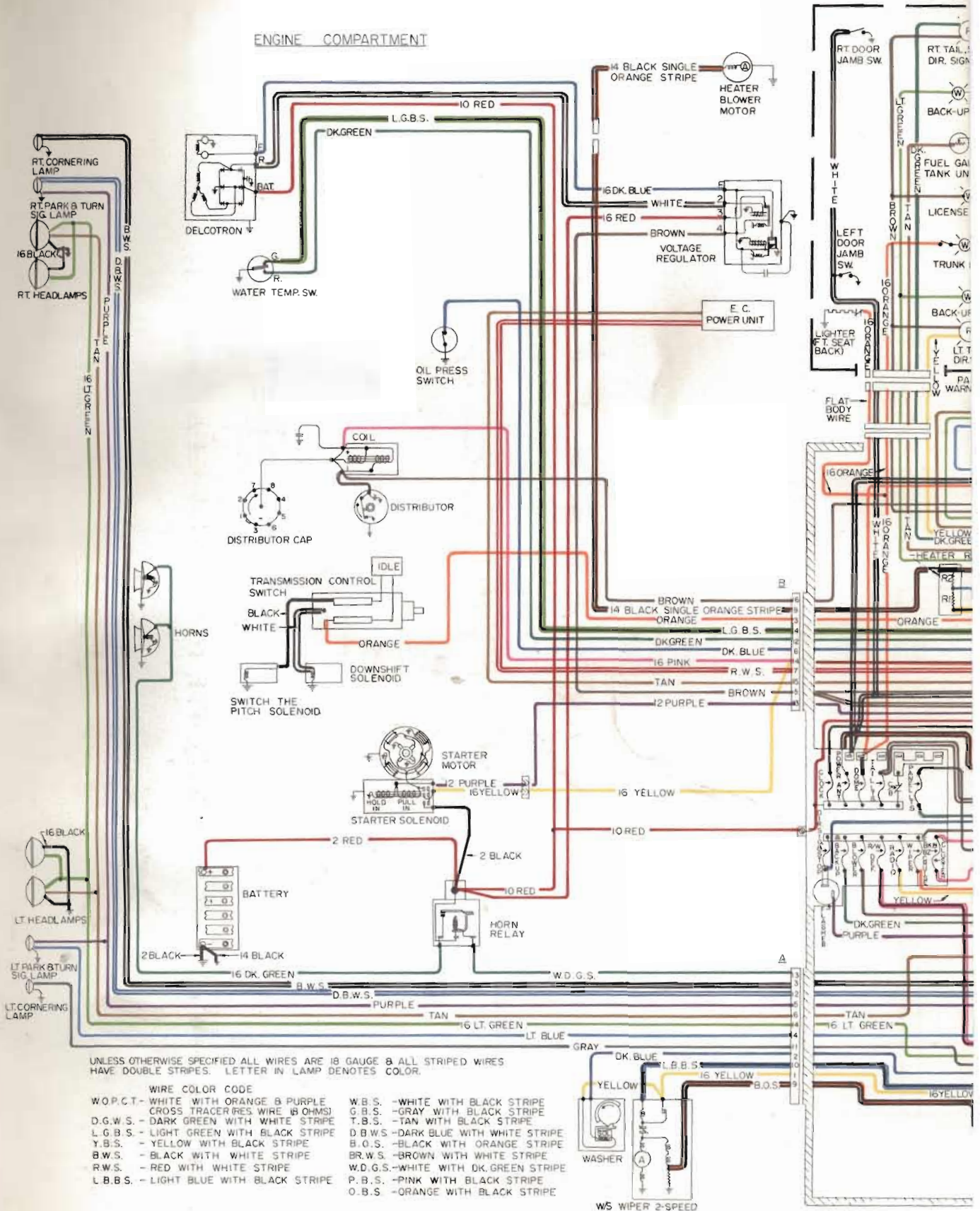
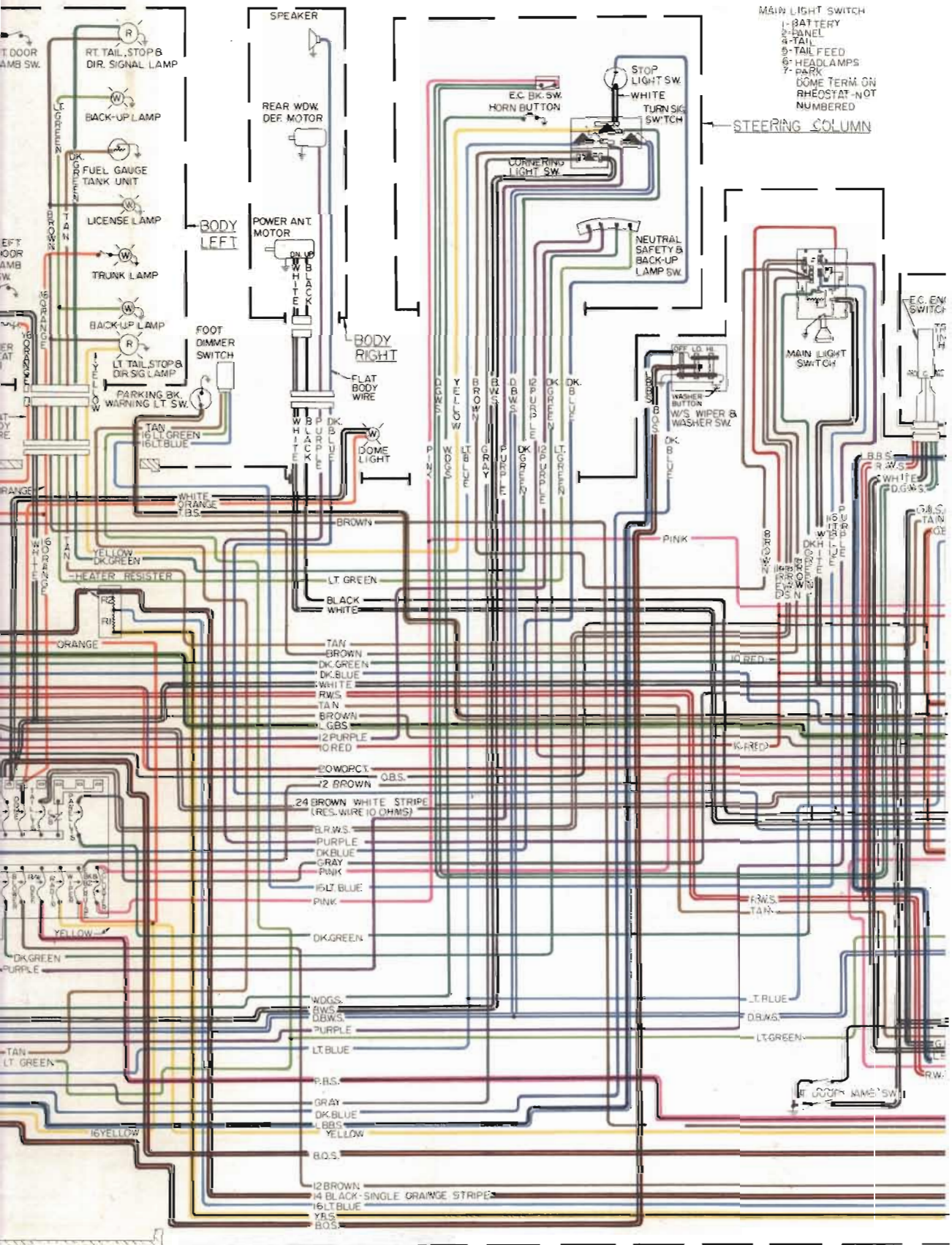
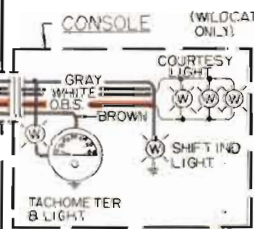
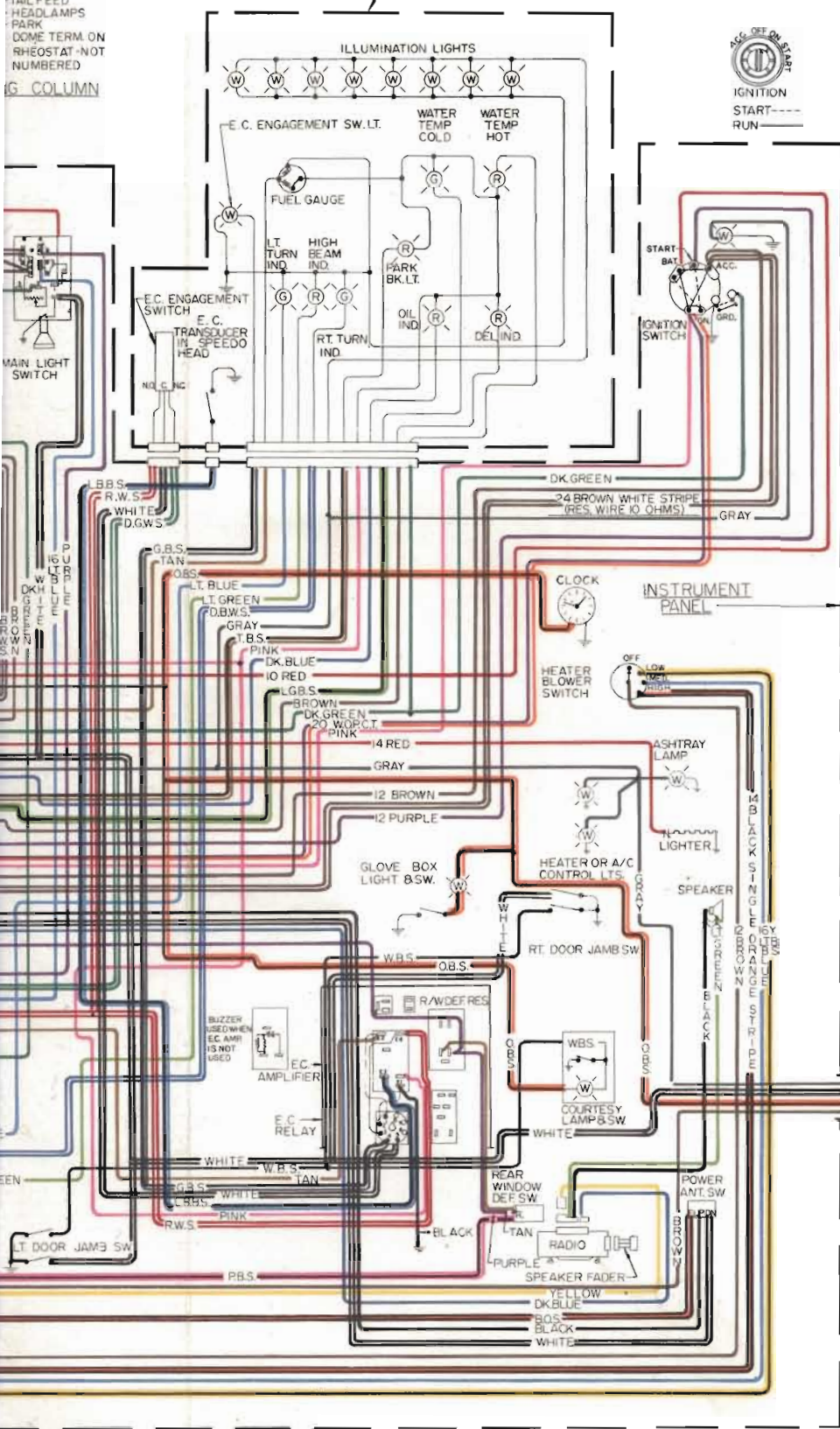

Figure 120-157—Wildcat & Electra Wiring Circuit Diagram



LIGHT SWITCH
BATTERY
PANEL
TAIL
TAIL FEED
HEADLAMPS
PARK
DOME TERM ON
RHEOSTAT - NOT
NUMBERED
G COLUMN



INSTRUMENT PANEL

CONSOLE (WILDCAT ONLY)

