

**SECTION 10-E**  
**CRANKING (STARTER) SYSTEM**

**CONTENTS OF SECTION 10-E**

Paragraph	Subject	Page	Paragraph	Subject	Page
10-31	The Cranking (Starter) System . . . . .	10-37	10-37	Voltage Test of Cranking Motor and Solenoid Switch	10-47
10-32	Accelerator Vacuum Switch—On Carter Carburetor . . . . .	10-39	10-38	Test and Adjustment of Solenoid Switch Relay . . . . .	10-48
10-33	Accelerator Vacuum Switch—On Stromberg Carburetor . . . . .	10-41	10-39	Solenoid Switch Test and Replacement . . . . .	10-50
10-34	Neutral Safety Switch—Dynaflow Drive . . . . .	10-44	10-40	Bench Test of Cranking Motor	10-51
10-35	Cranking Motor Assembly . . . . .	10-45	10-41	Cranking Motor Repairs—On Bench . . . . .	10-52
10-36	Periodic Inspection of Cranking Motor . . . . .	10-47			

**SERVICE BULLETIN REFERENCE**

Bulletin No.	Page No.	SUBJECT

**10-31 THE CRANKING (STARTER) SYSTEM**

**a. General Description**

The Buick cranking system permits the engine to be cranked by turning the ignition switch on and depressing the accelerator pedal. While accelerator pedal is depressed the cranking motor continues operation until the engine starts running on its own power, then the cranking motor circuit is automatically opened and the motor is disengaged from the flywheel ring gear.

The cranking system, shown schematically in figure 10-30, is composed of the following units:

1. *Battery* and *battery cables* (par. 10-14).
2. *Cranking motor*, including the drive assembly which engages the flywheel ring gear during cranking operation (par. 10-35).
3. *Cranking motor solenoid switch*, mounted on cranking motor, for shifting drive assembly and closing the motor circuit. Solenoid switch relay, mounted on cowl, for operating the solenoid switch (par. 10-35).
4. *Accelerator vacuum switch*, mounted on the carburetor and operated by the throttle shaft. This switch permits control of cranking system by the accelerator pedal (par. 10-22 and 10-33).

5. *Generator windings*, which are used for completing the vacuum switch and solenoid relay magnet coil circuit to ground.

6. *Charge indicator, ignition switch*, and necessary *wiring* to connect the various units.

7. *Neutral safety switch*, only on cars equipped with Dynaflow Drive. This switch is connected in series with the solenoid switch relay to prevent cranking of engine except when the transmission control lever is in either the neutral (N) or parking (P) position.

**b. Operation of Cranking System**

**CAUTION:** *The radio should be turned off while starting the engine because certain radio parts may be damaged if cranking motor is operated with radio turned on.*

When the ignition switch is turned on and the accelerator pedal is depressed to open the throttle valve in carburetor, the throttle shaft actuates the accelerator vacuum switch to close the switch contacts. *On Dynaflow Drive cars, the transmission control lever must be in neutral (N) or parking (P) position so that neutral safety switch is also closed.*

Closing of the ignition, vacuum, and neutral safety switches permits battery current to flow through the magnet windings of the solenoid

switch relay and through the field windings of the generator to ground. See figure 10-30. Flow of current through the relay windings magnetizes the core which pulls the relay armature down to close the relay contacts. Battery current then flows through the "pull in" and "hold in" coils of the solenoid, magnetizing the solenoid. The plunger is pulled into the solenoid so that it operates the shift lever to move the drive pinion into engagement with flywheel ring gear and then closes the solenoid switch contacts.

The closing of the solenoid switch contacts

causes the motor to crank the engine and also cuts out the "pull-in" coil of the solenoid, the magnetic pull of the "hold-in" being sufficient to hold the pinion in mesh after the shifting has been performed. This reduces the current consumed by the solenoid while the cranking motor is operating.

As soon as the engine starts running, the generator output voltage opposes the flow of current through the solenoid switch relay and generator windings, consequently the relay circuit ground connection is blocked and the circuit is opened.

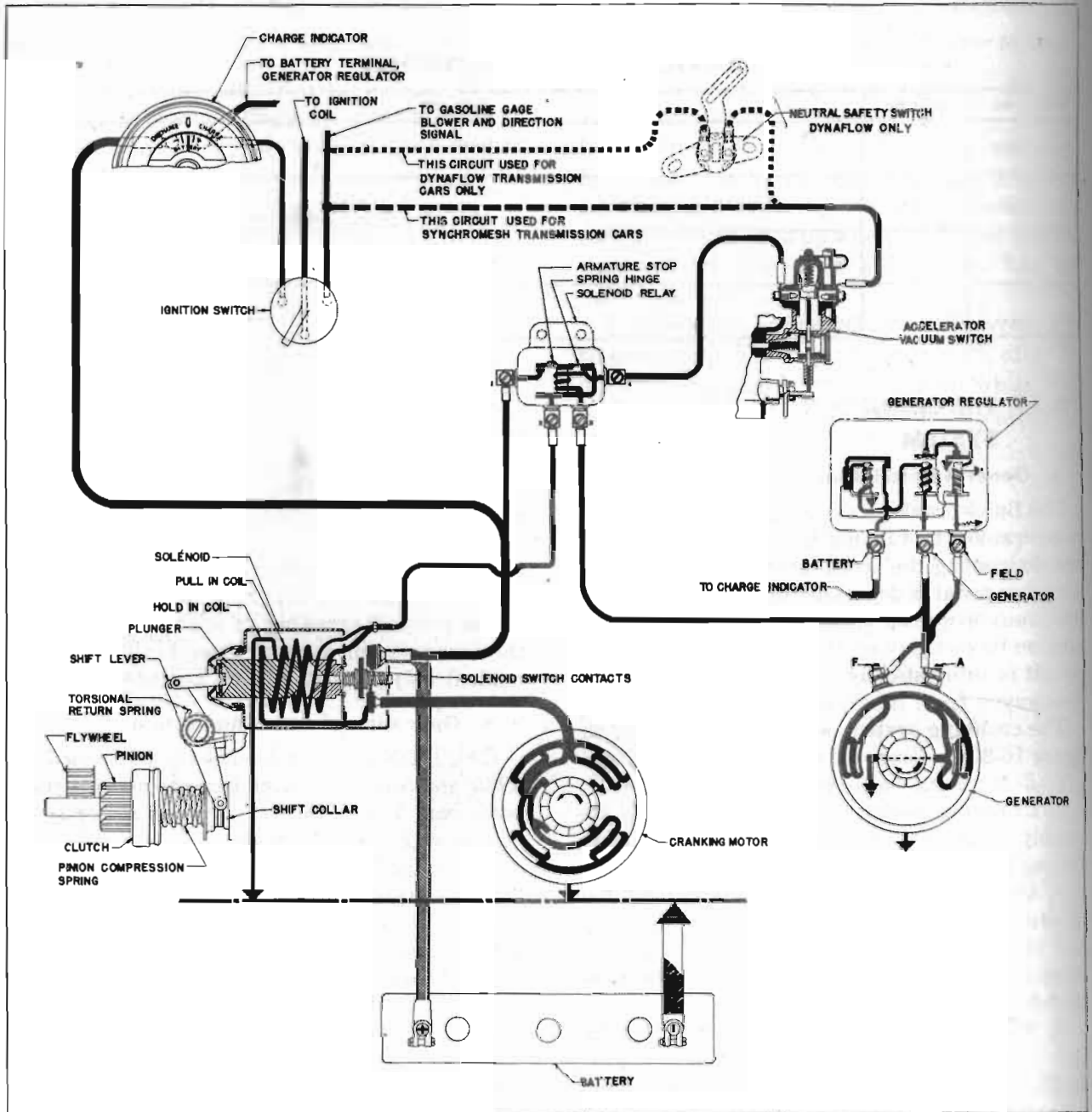

Figure 10-30—Cranking System Circuits

This demagnetizes the relay core and permits the relay contacts to open and break the solenoid circuit so that the solenoid is also demagnetized. A torsional return spring then actuates the shift lever to retract the solenoid plunger, which permits another spring to open the solenoid switch contacts. At the same time, the shift lever disengages the drive pinion from the flywheel ring gear.

Whenever the throttle is returned to idle position after the engine starts running, the accelerator vacuum switch contacts are separated and the solenoid switch relay circuit is opened at this point. Manifold vacuum controls a lock out device in the switch which prevents the contacts from closing when the throttle is again opened to accelerate the engine. These lockout devices are described in paragraphs 10-32 (Carter) and 10-33 (Stromberg).

In cold weather, if the first explosions are too feeble to keep the engine running under its own power the generator output voltage will not be sufficient to block the solenoid switch relay circuit and permit the relay contacts to open. If the throttle is held open the cranking motor will continue in operation until the explosions are strong enough to keep the engine running at a speed where generator output voltage is high enough to block the relay circuit and cut out the cranking system.

While the engine is running, operation of the accelerator pedal will not bring the cranking motor into operation because of two separate and independent safety features: (1) Blocking effect of generator voltage on solenoid switch relay circuit. (2) Mechanical lockout of switch contacts in the accelerator vacuum switch.

## 10-32 ACCELERATOR VACUUM SWITCH—ON CARTER CARBURETOR

### a. Description and Operation

The accelerator vacuum switch used on the Carter carburetor is built into the body flange in position to be operated by the throttle shaft.

The switch consists of a special stainless steel ball, plunger, guide block, W-shaped contact spring, and return spring housed in a passage in body flange which is closed by a terminal cap containing two contacts. When the engine is not running and throttle is closed, the ball rests on a lip on the lower end of switch plunger and bears against a flat spot on the throttle shaft. The plunger, guide block, and contact spring are held in a down position by the return spring so that the contact spring does not touch the contacts in terminal cap. See figure 10-31, view A.

When the accelerator is depressed with engine stopped and ignition switch turned on, the flat spot on throttle shaft acts as a cam to push the switch ball, plunger, guide block, and contact spring upward until the contact spring touches both controls in terminal cap. This closes the solenoid relay switch circuit and puts the cranking system into operation. See figure 10-31, view B.

After the engine starts running and the throttle is returned to idle position, manifold vacuum causes the ball to move upward against a seat in the body flange and the switch return spring pushes the contact spring and plunger down to separate the switch contacts, thereby opening the solenoid switch relay circuit at this point. See figure 10-31, view C. As long as the

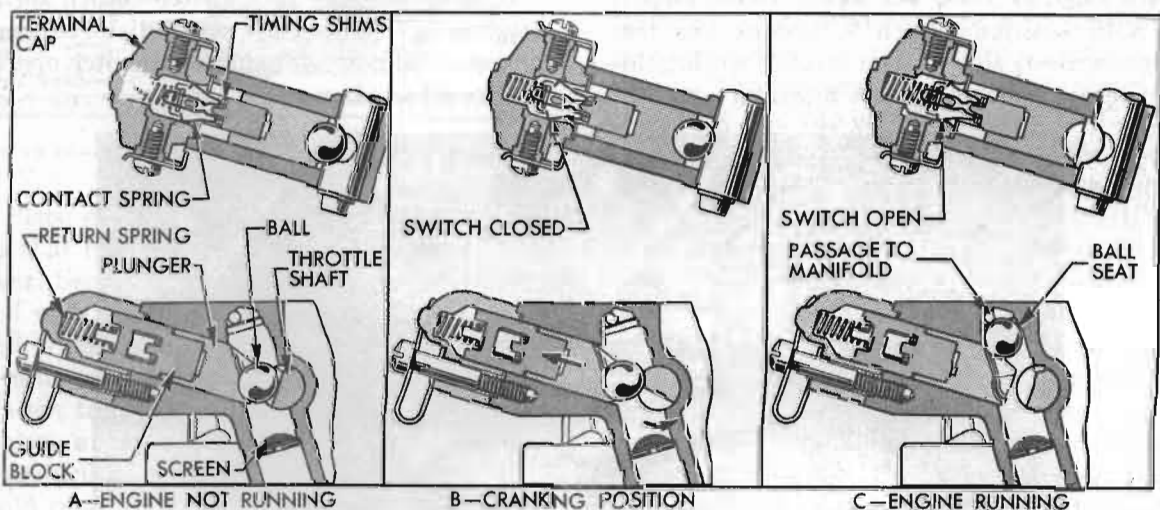

Figure 10-31—Carter Accelerator Vacuum Switch Operation

engine continues running the switch ball is held against its seat due to manifold vacuum; therefore movement of the throttle shaft cannot be transmitted to the plunger to close the switch contacts. When the engine stops so that manifold vacuum ceases, the ball drops down to the starting position between throttle shaft and plunger.

It is very important that the switch contact is made at a specific throttle opening, to assure proper starting conditions. If the switch makes contact too early the throttle will not be opened sufficient to give a good cold start. If the switch makes contact too late the throttle will be opened too far, which may cause gear clash as well as hard starting due to unloading of carburetor choke by the throttle mechanism. See subparagraph b, below.

#### b. Checking Vacuum Switch Timing

**CAUTION:** *If carburetor is installed on engine make certain that transmission is in neutral and parking brake is applied.*

1. If carburetor is installed on Dynaflow car make certain that throttle linkage and dash pot are correctly adjusted (par. 3-8).

1a. If carburetor is removed from engine, connect a 6-volt battery and test lamp across switch terminals so that lamp will light when switch makes contact.

2. Back off throttle stop screw, rotate fast idle cam to slow idle position if necessary, and fully close the throttle valve.

3. While holding throttle valve fully closed, hold a scale (or other strip of metal  $\frac{5}{8}$ " or more wide) against the choke unloader arm of throttle lever and make a pencil mark on float bowl at opposite edge of scale. See figure 10-32, step 1.

4. With ignition switch turned on (or test lamp connected) slowly open throttle while holding scale in position against unloader arm. At

point where the drive pinion just engages fly-wheel ring gear (or test lamp lights) make a second mark on float bowl at same edge of scale. See figure 10-32, step 2.

5. If switch is correctly timed the distance (X) between pencil marks on float bowl will be  $1\frac{5}{16}$ " to  $1\frac{3}{4}$ " on the *Series 40-50* 2-barrel carburetor, or  $\frac{3}{4}$ " to  $1\frac{1}{16}$ " on the *Series 70* 4-barrel carburetor.

6. If necessary, retune switch as described below (subpar. c); otherwise, set engine idle speed at 450 RPM when hot.

#### c. Cleaning and Timing Vacuum Switch

Switch timing may be changed without removing carburetor from engine; however, if switch is dirty the carburetor should be removed so that switch passages can be properly cleaned.

1. Disconnect wires from terminals. Hold down on switch terminal cap while removing hold down clip. Remove terminal cap and return spring, then lift out switch guide block with contact spring and shims. Do not lose timing shims and the spring washer on contact spring. See figure 10-33.

2. Remove plunger and steel ball from carburetor body flange.

3. Wash all metal parts in Bendix Metalclene, or its equivalent, and wipe dry. Clean out passages in carburetor body flange if dirty. Do not soak terminal cap and guide block in cleaning solution, but wipe with a clean cloth.

4. Check condition of contact spring and replace it if burned or otherwise damaged. The free width of spring across the points, with return spring washer in place is  $\frac{7}{16}$ " +  $\frac{1}{32}$ " - 0. See figure 10-33.

5. The free length of switch return spring is  $1\frac{1}{16}$ " to  $\frac{3}{4}$ ". Replace a weak or distorted spring; do not stretch or alter spring as switch operation will be affected.

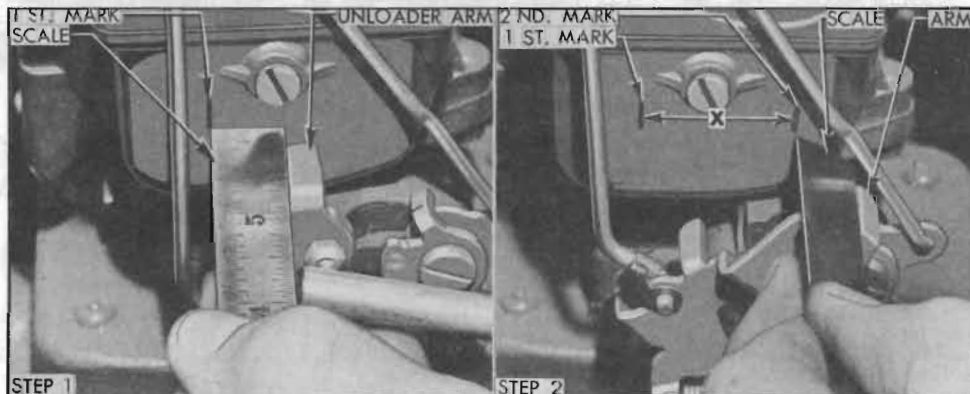

Figure 10-32—Checking Carter Accelerator Vacuum Switch Timing

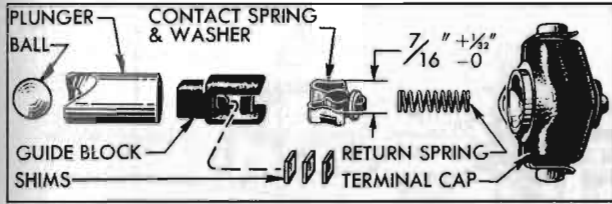

Figure 10-33—Carter Accelerator Vacuum Switch Parts

6. The contact spring rests on a number of square brass shims which control the switch timing. If switch timing was found to be too early (subpar. *b*, above), reduce the total thickness of these shims. If timing was too late, increase total thickness of shims. These shims are furnished in thicknesses of .006" and .018".

7. Before installing parts, the contact surfaces in terminal cap should be given a light coating of Standard Oil Rocker Arm Grease No. 1 or Beacon M-285 lubricant. If these lubricants are not available petroleum jelly may be used. Work lubricant into a piece of clean cloth and lightly swab the inside of terminal cap. **CAUTION:** Do not use ordinary lubricants as poor switch contact will be obtained in cold weather. Do not apply lubricant to the ball or plunger.

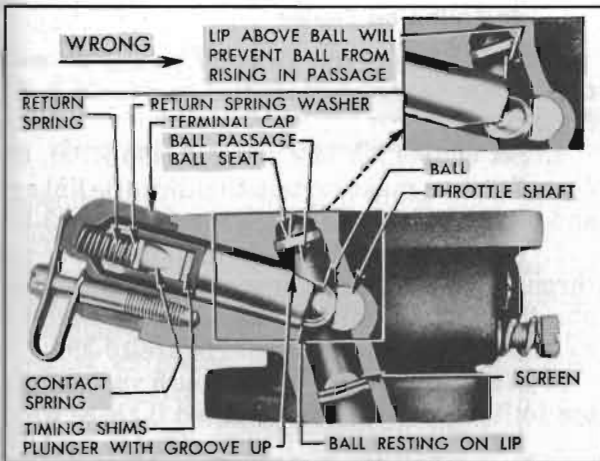

Figure 10-34—Assembly of Carter Accelerator Vacuum Switch

8. Place plunger in position with the groove up so that the ball rests on lip at inner end of plunger. See figure 10-34. If the plunger is installed with groove down, the ball will be prevented from rising into the ball passage when the engine starts. As a result, the switch will close each time the throttle is opened, causing gear clash at low speeds when the generator is not producing sufficient voltage to open the solenoid relay. If generator should be inoperative, gear clashing would occur at all speeds.

9. Make sure that all timing washers, contact spring, and the return spring washer are in proper position before installing the return spring and terminal cap. Make sure that terminal cap is properly seated. See figure 10-34.

10. After switch is assembled, check the timing as described above (subpar. *b* or *c*), and change shims as required until proper timing is obtained.

### 10-33 ACCELERATOR VACUUM SWITCH —ON STROMBERG CARBURETOR

#### a. Description and Operation

The accelerator vacuum switch used on Stromberg carburetors is mounted on the throttle body of the carburetor by two screws. A gasket placed between the switch housing and the throttle body seals against loss of vacuum.

The switch housing is provided with a horizontal cylinder barrel to which vacuum from the engine manifold is applied at one end by means of cored and drilled passages in the carburetor bodies. This end of the barrel is provided with a washer which forms a seal to prevent leaks when a piston opposed by a light spring is drawn against it by vacuum. The opposite end of the barrel is vented to outside air through a fine mesh screen and felt filter held in place by a washer and clip. A flat slide, actuated by an operating lever on the throttle shaft, moves in a confined slot in the housing and in a plane perpendicular to the axis of the cylinder barrel. This slide engages a cylindrical bakelite contact guide, the upward movement of which is opposed by a heavy contact guide spring. The contact guide carries a thin U-shaped spring contact which moves up and down within a bakelite terminal cap to engage stationary contacts for opening and closing the cranking motor control circuit. The terminal cap is held in place by a cap screw and cap clip. See figure 10-35

Figure 10-35 shows the accelerator vacuum switch with engine not running. The throttle is closed and the switch operating lever holds the slide in the upper position, thereby holding the U-shaped spring contact away from the stationary contacts in the terminal cap.

Pressing down on the accelerator pedal causes the operating lever to move away from the slide. This allows the contact guide spring to move the slide and U-shaped spring contact down to a position to bridge the stationary contacts in the terminal cap, thus closing the circuit. The slide moves into the deeper of the two grooves

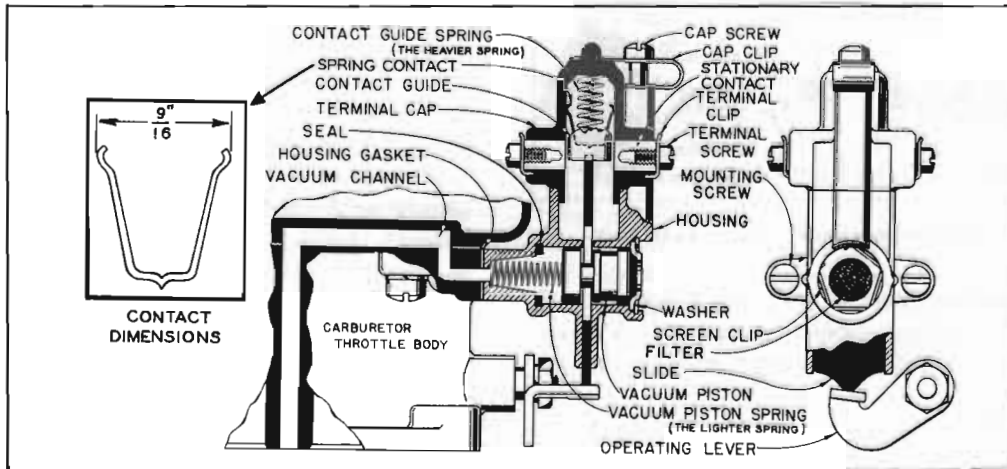

Figure 10-35—Stromberg Accelerator Vacuum Switch—Engine Not Running

in the vacuum piston which has been positioned against the screen by the vacuum piston spring. See figure 10-36.

When the engine starts and the throttle is allowed to close, the slide and U-shaped spring contact is moved upward by the switch operating lever, opening the circuit. With the slide in the up position, manifold vacuum pulls the vacuum piston inward until it seats against the seal. This aligns the shallow groove in piston with the slide. See figure 10-37.

When the throttle is opened beyond the idle range, the operating lever moves away from the slide which is then forced downward by the contact guide spring until it strikes the shallow groove in the vacuum piston. This acts as a stop and prevents the switch contacts from engaging while engine is running. It also holds the piston in the inner position when engine load conditions cause the vacuum to become too low to perform this function. See figure 10-38.

It is very important that the switch contact is made at a specific throttle opening, to assure

proper starting conditions. If the switch makes contact too early the throttle will not be opened sufficiently to give a good start. If the switch makes contact too late the throttle will be opened too far, which may cause gear clash as well as hard starting due to unloading of carburetor choke by the throttle mechanism. See subparagraph *b*, below.

#### b. Checking Switch Timing with Carburetor Installed on Engine

**CAUTION:** Before checking timing be sure that transmission is in neutral and apply parking brake.

1. Set engine *hot idle* speed at 450 RPM. On *Dynaflow* car, make certain that throttle linkage and dash pot are correctly adjusted (par. 3-8).
2. With engine not running, insert a pin through center of felt filter and screen to operate the vacuum piston. **DO NOT REMOVE FILTER AND SCREEN.** See figure 10-39.
3. With throttle closed, first push vacuum piston to its inner position and hold it there while

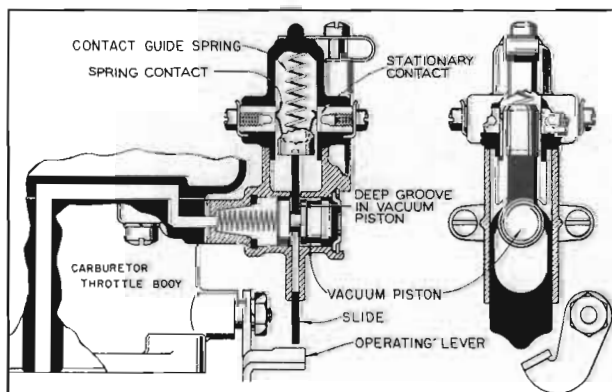

Figure 10-36—Stromberg Accelerator Vacuum Switch—Cranking Position

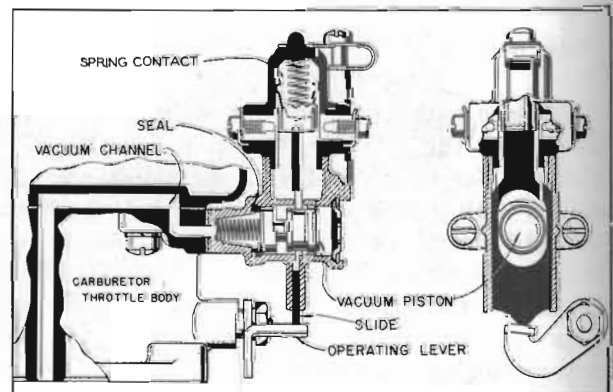

Figure 10-37—Stromberg Accelerator Vacuum Switch—Engine Running at Closed Throttle

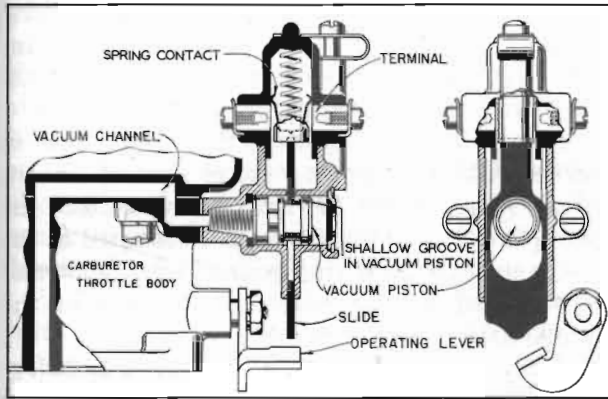

Figure 10-38—Stromberg Accelerator Vacuum Switch—Engine Running at Part or Open Throttle

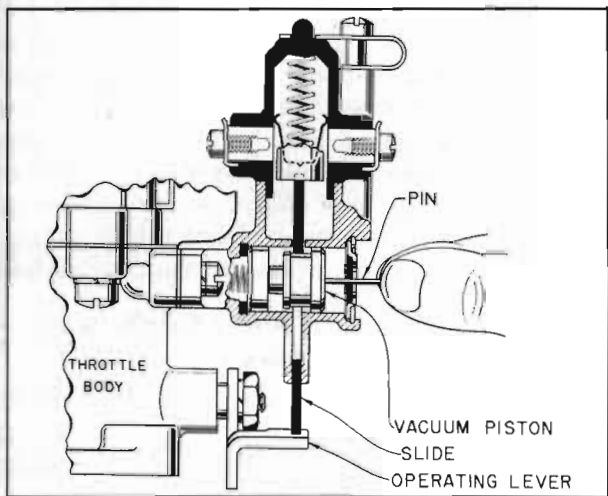

Figure 10-39—Pushing Vacuum Piston to Inner Position

opening throttle. This will allow slide to drop into the shallow groove in the piston and will lock it in the inner position and prevent slide from dropping far enough to complete contact. See figure 10-39. Hold throttle open to prevent release of piston until completion of Steps 4 and 5. Remove pin.

4. Place  $\frac{5}{64}$ " spacer between idle stop screw and fast idle cam while holding fast idle cam in extreme cold idle position. Close throttle so that spacer will hold cam in this position. See figure 10-40. Turn ignition on, hold spacer and open throttle. *Engine should not crank.*

NOTE: A test light with a battery may be used in series with switch instead of turning on ignition.

5. Still holding throttle open, place  $\frac{3}{64}$ " spacer between idle stop screw and fast idle cam while holding fast idle cam in extreme cold idle position. Close throttle so that spacer will hold cam in this position (fig. 10-40) and again open throttle with ignition on. *Engine should crank.*

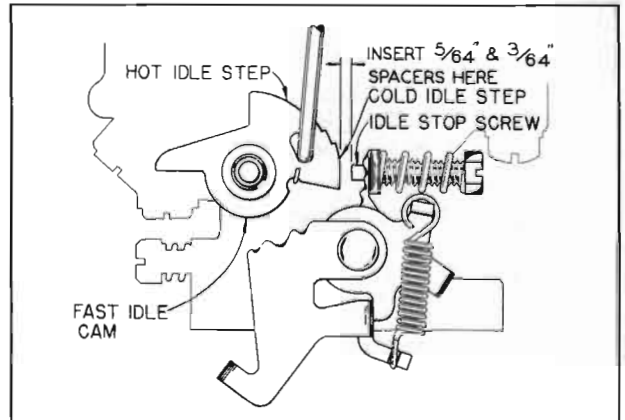

Figure 10-40—Spacer Between Idle Stop Screw and Fast Idle Cam

6. If the  $\frac{5}{64}$ " spacer causes the engine to crank, bend tang on operating lever downward. If the  $\frac{3}{64}$ " spacer does not cause engine to crank, bend tang on lever upward. In making either adjustment bend tang on operating lever only a slight amount each time until, by rechecking with the above procedure, the specified spacing is obtained.

### c. Setting Switch Timing with Carburetor Removed from Engine

If the carburetor has been removed from the engine an approximate switch timing setting may be made as follows:

1. On *Series 40-50*, place a No. 43 drill between throttle valve and carburetor barrel. On *Series 70*, use a No. 41 drill. Close throttle valve to hold drill in position.

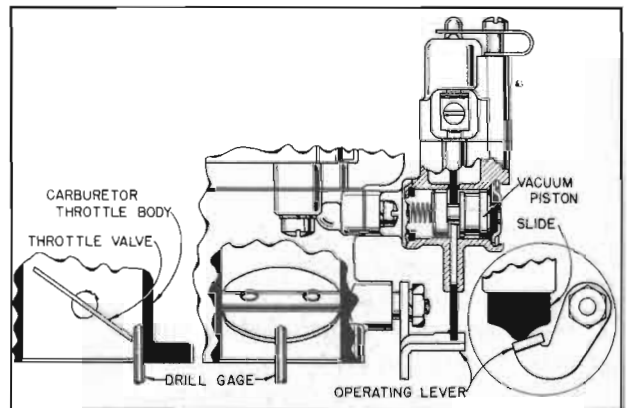

Figure 10-41—Setting Switch Timing with Carburetor Removed

2. Bend tang on switch operating lever until it just touches switch slide. See figure 10-41.

3. After carburetor is installed on engine, always recheck switch timing as described in subparagraph b, above.

**d. Cleaning and Lubricating Switch**

The accelerator vacuum switch may be removed for cleaning or replacement of parts without removing the carburetor. Disconnect wires and remove two screws which attach switch to the throttle body of carburetor.

The switch may be readily disassembled by referring to figure 10-35. Wash all metal parts in Bendix Metalclene, or equivalent, and wipe dry. Do not soak bakelite parts in cleaning solution, but wipe with a clean cloth.

Lubrication of switch contacts is unnecessary unless parts have been cleaned or replaced, in which case the inside surface of the terminal cap should be given a *light* coating of Beacon M-285 lubricant which is available in small tubes at authorized Stromberg Carburetor Service Stations. If this lubricant is not available petroleum jelly may be used. Lubricant should be applied sparingly by working into a clean cloth and lightly swabbing the inside surface of terminal cap.

**CAUTION:** *Never use ordinary lubricants, as poor switch contact will be obtained in cold weather. Never apply lubricant to slide or piston.*

When switch is reassembled observe the following points:

1. Make certain that the contact guide spring and the vacuum piston spring are installed in their proper positions. The contact guide spring may be identified as the heavier of the two springs. See figure 10-35.

2. Make certain that piston is installed with the end having the deep groove and tapered counterbore nearest the seal.

3. Use care in handling the U-shaped contact spring to avoid altering the dimension of the open end. The open end measures  $\frac{3}{16}$ " from outside to outside of the curved ends of spring. See figure 10-35.

4. Make certain that the narrow projection on top of slide is properly entered in the slot in bottom of contact guide.

When switch is reinstalled on carburetor use a new gasket to insure a vacuum-tight seal. Check and set switch timing as described in subparagraph *b*, above.

**10-34 NEUTRAL SAFETY SWITCH—  
DYNAFLOW DRIVE CARS**

Dynaflow Drive cars are provided with a neutral safety switch which prevents operation of the cranking motor except when the trans-

mission is in the Neutral (N) or Park (P) positions. This switch is a safety feature installed for the purpose of preventing car motion when starting the engine.

The neutral safety switch is connected in series with the cranking motor control circuit, in the line between the ignition switch and the accelerator vacuum switch. It is mounted at the lower end of the steering gear column jacket and is operated by the lever at lower end of the transmission control shaft.

When properly adjusted, the neutral safety switch remains closed, to permit cranking the engine, until the center of speed ratio dial pointer is moved approximately  $\frac{5}{32}$ " out of neutral (N) toward driving (D) position.

If the switch opens when center of pointer is less than  $\frac{1}{8}$ " from neutral, the cranking motor control circuit may not be completed when transmission control lever is in neutral. If the switch remains closed when center of pointer is more than  $\frac{3}{16}$ " out of neutral, the cranking motor might be operated before the transmission is completely out of the driving (D) range.

**a. Checking Neutral Safety Switch Timing  
Adjustment with Gauge**

1. Check manual control linkage and adjust if necessary (par. 4-26).
2. Ground primary terminal of distributor with jumper wire so that engine can be cranked without firing.
3. Firmly engage "step-on" parking brake and place transmission control lever in neutral (N) position, making sure that detent is firmly engaged.
4. Install Gauge J 3085 on speed ratio dial housing so that the *short* line under "N" is centered on the dial pointer. See figure 10-42.
5. Move control lever to driving (D) position, turn ignition on and depress accelerator

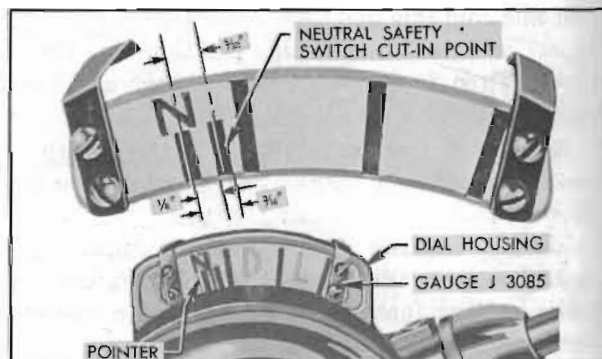

Figure 10-42—Gauge J 3085 Set for Timing the Neutral Safety Switch



pedal to close accelerator vacuum switch.

6. Slowly move dial pointer from "D" toward "N" and note position of *center* of pointer at instant that cranking motor just starts to operate. Release accelerator pedal.

7. The *center* of dial pointer should be within the limits of the *short* line just to right of "N" mark on gauge. This line provides the required limits of  $\frac{1}{8}$ " to  $\frac{3}{16}$ " out of neutral.

8. If the neutral safety switch does not cut in within the required limits, adjust switch timing according to the following steps.

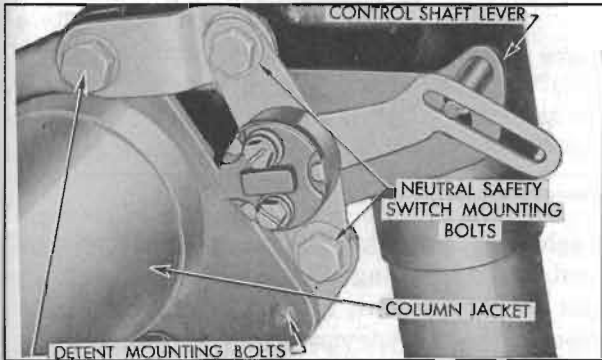

Figure 10-43—Neutral Safety Switch Mounting

9. Loosen neutral safety switch mounting bolts at lower end of steering gear column jacket (fig. 10-43) and raise switch up as far as it will go.

10. Have a helper hold control lever so that dial pointer is centered behind the short cut-in mark on gauge J 3085, turn on ignition and depress accelerator pedal.

11. Gently tap neutral safety switch downward until cranking motor just starts to operate, then tighten switch mounting bolts without moving switch. Helper should release accelerator pedal when cranking motor starts to operate.

12. Recheck switch timing as in Steps 5 and 6. Remove jumper wire from distributor and gauge from dial housing when switch timing is correctly adjusted.

#### b. Checking Neutral Safety Switch Timing Adjustment Without Gauge

The neutral safety switch timing can be most easily checked and adjusted by use of Gauge J 3085 as described above. If this gauge is not available, the following method may be used.

1. Place a narrow strip of masking tape on speed ratio dial so that upper end of dial pointer is visible.

2. Make two marks on masking tape at  $\frac{1}{8}$ " and  $\frac{3}{16}$ " from *center* of pointer. See figure 10-44.

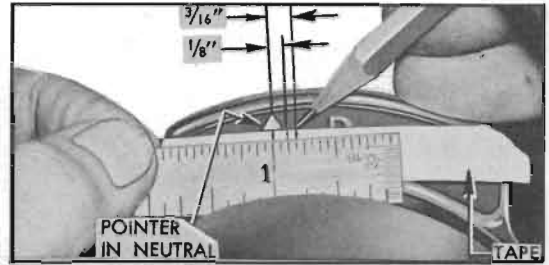

Figure 10-44—Marking Tape for Checking Switch Timing

These marks give the same cut-in limits as provided by Gauge J 3085.

3. Check and adjust switch timing in the same manner as with Gauge J 3085 (subpar. b).

### 10-35 CRANKING MOTOR ASSEMBLY

The cranking motor assembly consists of a motor, drive assembly, shift lever, solenoid switch and relay. See figure 10-45. It is mounted on the flywheel upper housing on the right side of engine.

#### a. Cranking Motor

The motor used on *Series 40-50* is of the induced pole type having four brushes and four poles but only two field coils. The motor used on *Series 70* is a four pole motor having four brushes and four field coils. Both motors are series-wound.

The armature shaft is supported at both ends in graphite bronze bushings pressed into the commutator end frame and the drive housing. In the *Series 70* motor, the shaft is also supported by a graphite bronze bushed center bearing plate which is mounted on the inner end of the drive housing. None of these bearings require lubrication. See figure 10-45.

The four brushes are supported by brush holders mounted on the commutator end frame. Two opposing brushes are grounded to the frame and the other two opposing brushes are connected to the field coils. The field coils are held in place by the pole shoes which are attached to the field frame by large screws. The field coils are connected to an insulated terminal stud on the field frame, through which current is supplied to the motor.

#### b. Cranking Motor Drive Assembly and Shift Lever

The drive assembly is mounted on the motor armature shaft and keyed to it by splines so that it can be moved endwise on the shaft by

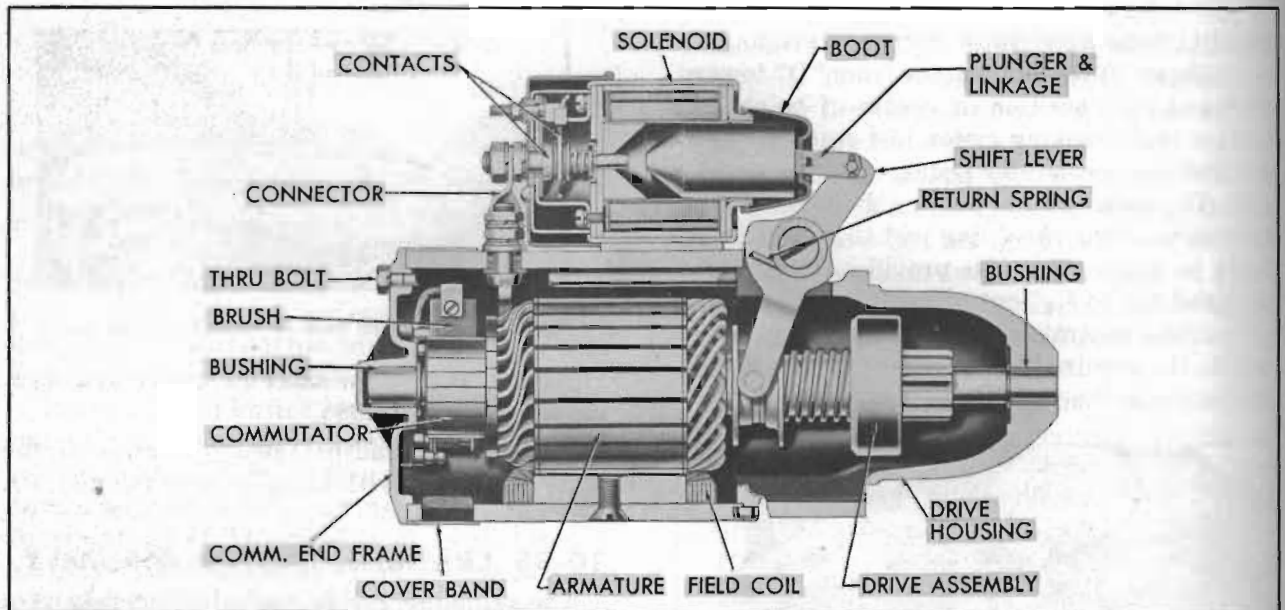

Figure 10-45—Cranking Motor, Sectional View—Series 40-50

the solenoid operated shift lever. It transmits cranking torque to the flywheel ring gear, but allows the drive pinion to rotate freely with reference to the armature shaft when the engine begins to operate, thus preventing the armature from being driven at excessive speed by the engine.

The drive assembly consists of a pinion-and-collar, overrunning clutch, spring, and shift collar. The overrunning clutch consists of a shell and sleeve assembly, which is internally splined to the armature shaft. The pinion collar fits within the clutch shell. Four tapered notches cut in the clutch shell house four hardened steel rolls in position so that they can bear against the pinion collar. A spring and plunger presses each roll toward the small end of the notches and into contact with the pinion collar. See figure 10-46.

When the clutch shell is rotated by the armature shaft, the rolls jam between the shell and pinion collar and force the pinion to rotate with the shell. When the pinion is rotated by the flywheel ring gear, after the engine starts, the rolls are rotated out of the small end of the notches so that the pinion collar and clutch shell are no longer locked together, consequently the high speed of the pinion is not transmitted to the armature shaft.

The drive assembly pinion is moved into engagement with flywheel ring gear by action of the solenoid upon the shift lever, which engages the shift collar of drive assembly. The shift collar moves the drive assembly by pushing on the clutch spring, which serves as a

cushion in case the pinion and gear teeth butt instead of meshing. The drive pinion is pulled out of engagement, after engine starts, by action of the shift lever return spring. The shift lever is connected to the solenoid switch plunger by a link and adjusting screw. See figure 10-45.

### c. Solenoid Switch and Relay

The solenoid switch not only closes the circuit between the battery and the cranking motor to produce cranking action, but it also operates the shift lever to move the drive pinion into engagement with the flywheel ring gear.

The solenoid section of the switch has a plunger and two windings, the "pull-in" winding and the "hold-in" winding. Together, they provide sufficient magnetic attraction to pull the solenoid plunger into the solenoid. The plunger actuates the shift lever and drive assembly and it also closes the solenoid switch contacts by pressing against a push rod upon which a contact disk is mounted between two

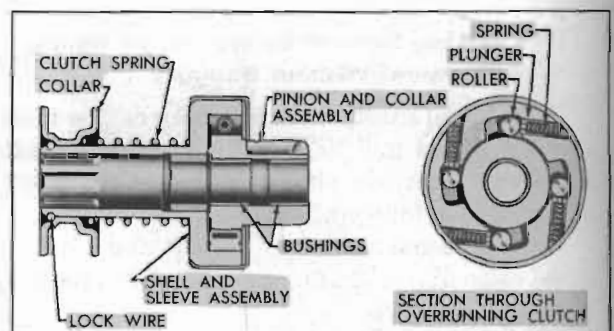

Figure 10-46—Cranking Motor Drive Assembly, Sectional Views

coil springs. One spring serves as a cushion to insure firm contact of the disk with two stationary contacts. The other spring pushes the disk away from the stationary contacts to break the circuit when the solenoid is demagnetized after the engine starts. One stationary contact is connected to the battery positive cable and the other is connected to the motor windings through a connector or bus bar. See figure 10-45.

The solenoid switch relay is an electrical switch which closes the circuit between the battery and the solenoid windings when cranking action is desired, and opens the circuit when the engine starts running. The relay has one winding surrounding a core which, when magnetized by current flowing through the winding, attracts a flat steel armature. The armature has a contact point which makes contact with a stationary point to close the circuit.

Operation of the solenoid switch and relay, as well as the entire cranking system, is described in paragraph 10-31.

### 10-36 PERIODIC INSPECTION OF CRANKING MOTOR

As a general rule, the cranking motor should be tested and inspected every 5000 miles to determine its condition; however, the type of service in which some cranking motors are used may make more frequent inspection advisable. Frequent starts, as in city operation, excessively long cranking periods caused by hard-starting engine conditions, excessively dirty or moist operating conditions, all will make more frequent inspection advisable.

Cranking motor action is indicative, to some extent, of the cranking motor condition. A cranking motor that responds readily and cranks the engine at normal speed when the control circuit is closed is usually in good condition. The following inspection should be made, however, to insure continued satisfactory operation.

1. Remove commutator cover band and inspect it for thrown solder which results if cranking motor is subjected to excessively long cranking periods, causing it to overheat. Since thrown solder results in loose or broken connections between armature windings and commutator riser bars, which usually causes burned commutator bars, the motor must be removed for repairs (par. 10-41).

2. Inspect commutator; if it is rough, out of round, or has high mica between the bars it

will require turning down and undercutting of the mica. The motor must be removed for this work.

3. Check condition of brushes; make sure they are not binding and that they are resting on the commutator with sufficient tension to give good, firm contact. Brush leads and screws must be tight. If the brushes are worn down to one-half their original length, compared with new brushes, the motor must be removed for installation of new brushes.

4. If commutator and brushes are in good condition but dirty, they may be cleaned without removal of motor. Clean off any grease with a cloth soaked with carbon tetrachloride or other non-inflammable solvent. While motor is operating, quickly polish commutator with a brush seating stone or with a strip of 2/0 sandpaper placed over a wooden block having a smooth square end. *Do not use emery cloth.* To operate cranking motor, turn ignition switch off and connect a jumper wire between battery terminal of solenoid switch and the terminal of solenoid relay to which the wire with black parallel tracer is connected. **CAUTION:** *Do not operate cranking motor more than 30 seconds at a time without pausing to allow motor to cool for at least two minutes; otherwise, overheating and damage to motor may result.* After cleaning commutator, blow out all dust from cranking motor.

5. Check motor and solenoid switch attaching bolts to make sure these units are solidly mounted. Inspect and manually check all wiring connections at solenoid switch, solenoid relay, generator regulator, generator, accelerator vacuum switch, ignition switch, No. 1 terminal of headlamp lighting switch, charge indicator, and neutral safety switch (Dynaflow Drive cars only). Make sure that all these connections in the cranking motor and control circuits are clean and tight. It is advisable to test the cranking circuit to make certain that excessive resistance does not exist. See paragraph 10-37.

### 10-37 VOLTAGE TEST OF CRANKING MOTOR AND SOLENOID SWITCH

The voltage across the cranking motor and switch while cranking the engine gives a good indication of any excessive resistance. **NOTE:** *Engine must be at normal operating temperature when test is made.*

1. Inspect battery and cables (par. 10-17)

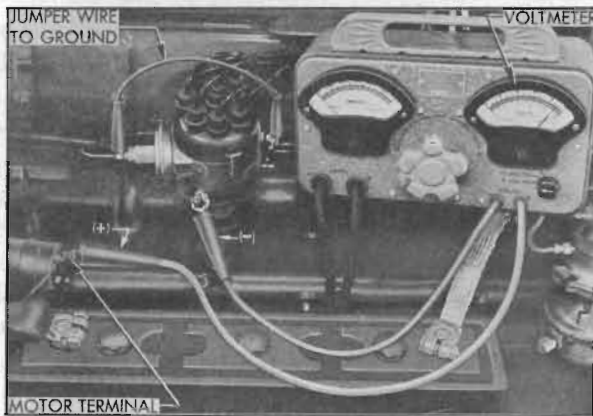

Figure 10-47—Cranking Voltage Test Connections

to make certain that battery has ample capacity for cranking and ignition.

2. Connect jumper wire to primary terminal of distributor and to ground on engine, so that engine can be cranked without firing.

3. Connect voltmeter positive (+) lead to the motor terminal on solenoid switch; connect voltmeter negative (-) lead to ground on engine. See figure 10-47.

4. Turn ignition switch on, crank engine and take voltmeter reading as quickly as possible. If cranking motor turns engine at normal cranking speed with voltmeter reading 4.5 or more volts, the motor and switch are satisfactory. If cranking speed is below normal and voltmeter reading is 4.5 or greater, the cranking motor is defective.

**CAUTION:** Do not operate cranking motor more than 30 seconds at a time without pausing to allow motor to cool for at least two minutes; otherwise, over heating and damage to motor may result.

5. If cranking motor turns engine at low rate of speed with voltmeter reading less than 4.5 volts, test solenoid switch contacts as follows.

6. With voltmeter switch turned to any scale above 6 volts, connect voltmeter negative (-) lead to the motor terminal of solenoid switch, and connect positive (+) lead to battery terminal of switch. See figure 10-48.

7. Turn ignition switch on and crank engine. Immediately turn voltmeter switch to low scale and take reading as quickly as possible, then turn switch back to higher scale and stop engine.

The voltmeter will read not more than  $\frac{1}{10}$  volt if switch contacts are satisfactory. If voltmeter reads more than  $\frac{1}{10}$  volt, switch should be repaired or replaced.

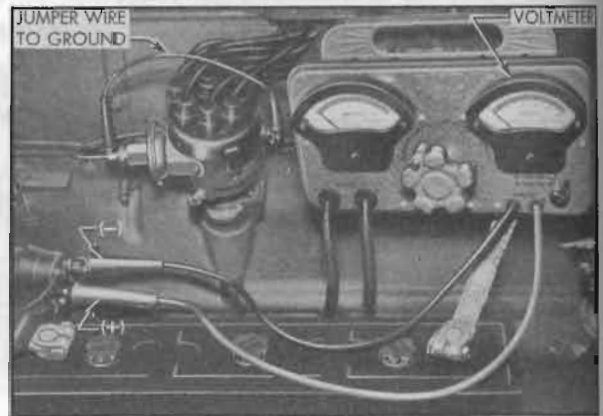

Figure 10-48—Solenoid Switch Contact Test Connections

### 10-38 TEST AND ADJUSTMENT OF SOLENOID SWITCH RELAY

The solenoid switch relay must close at very low voltage in order to assure positive operation in cold weather when the battery may be low. Because it is calibrated at low voltage no attempt should be made to test or adjust it without accurate test equipment.

The switch relay may be tested on the car with the following equipment: (1) 6-volt test lamp (2) Accurate low reading voltmeter (3) Variable rheostat of at least 10 ohms and a capacity of 2 amperes. The Ohmite Model J rheostat, 50 watt stock No. 0314, 12 ohms 2.05 max. amp., is satisfactory. It is made by Ohmite Manufacturing Co., and is available at most electrical supply stores.

#### a. Testing Solenoid Switch Relay Closing, Sealing, and Opening Voltages

**NOTE:** Relay must be tested cold (at room temperature).

1. With ignition switch turned off, remove red and black cross wire from relay terminal marked (2) in figure 10-49.

2. Connect 6-volt test lamp between relay terminal marked (2) and ground on relay mounting bolt.

3. Connect lead attached to rotating arm of rheostat to relay terminal marked (4). Connect one resistance lead to relay terminal marked (1) and connect the opposite lead to relay mounting bolt. See figure 10-49.

4. Connect leads of low reading voltmeter to relay terminals marked (3) and (4).

5. Turn rheostat arm until voltmeter reads zero then slowly turn arm and note voltmeter reading at instant that test lamp lights, indi-

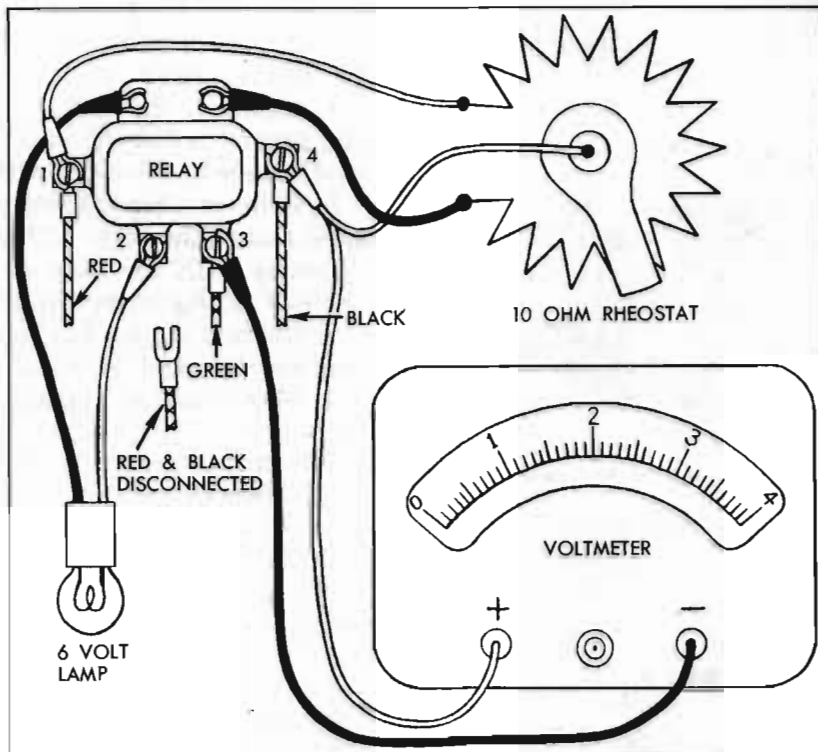

Figure 10-49—Solenoid Switch Relay Test Connections

cating that relay contacts have closed. This *closing voltage* should be between 1.5 and 2.1 volts.

6. Continue to slowly turn rheostat arm in same direction and note voltmeter reading at instant that a slight click occurs in relay, indicating that relay armature has sealed to the magnet core. This *sealing voltage* should be not more than 0.1 volt above the closing voltage obtained in step 5.

7. Quickly turn rheostat arm until voltmeter reads 6 volts, for the purpose of fully saturating the relay magnet core.

8. As quickly as possible turn rheostat arm to decrease indicated voltage, noting voltmeter reading at instant that test light goes out as relay contacts open. This *opening voltage* should be not less than 0.35 volts.

9. If the solenoid switch relay does not operate within the specified voltage limits it may be adjusted as described below (subpar. b).

#### b. Solenoid Switch Relay Adjustments

1. Remove relay from car and remove the cover, which is crimped in place.

2. Push relay armature down until contact points just touch, then check air gap between armature and core with feeler gauges. Air gap should be .011" minimum and may be adjusted, if necessary, by bending the lower point support. See figure 10-50.

3. With armature free, check contact point opening with feeler gauges. Point opening should be between .020" and .030" and may be adjusted, if necessary, by bending the upper armature stop. See figure 10-51.

4. Connect the positive terminal of a 6-volt battery to relay terminal marked (1); connect the negative terminal of battery to relay terminal marked (3) and also to ground on relay mounting bracket.

5. Connect a 6-volt test lamp, low reading voltmeter and 10 ohm rheostat to relay terminals as shown in figure 10-49.

6. Test relay closing voltage as previously described in subparagraph a, step 5. If voltage

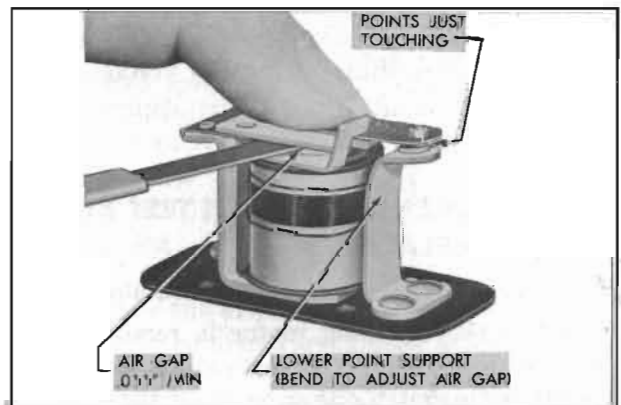

Figure 10-50—Relay Air Gap Adjustment

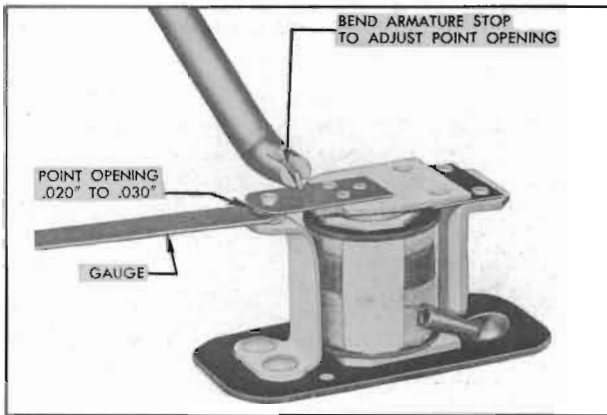

Figure 10-51—Relay Contact Point Adjustment

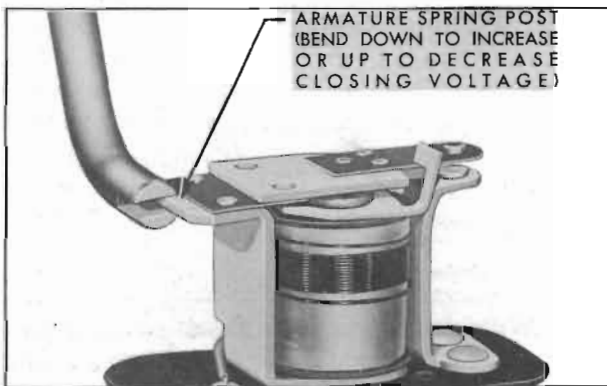

Figure 10-52—Relay Closing Voltage Adjustment

is not within specified limits, bend armature spring post down to increase spring tension and closing voltage, or bend up to decrease voltage. See figure 10-52. Recheck closing voltage after each adjustment.

7. After the specified closing voltage is obtained, test the sealing and opening voltages as previously described in subparagraph *a*, steps 6, 7, 8.

8. Sealing and opening voltages can be adjusted by varying the adjustments of air gap or closing voltage within specification limits. Closing voltage should be rechecked after adjustments of sealing or opening voltage.

9. After all adjustments are completed, install relay cover and reinstall relay on car.

### 10-39 SOLENOID SWITCH TEST AND REPLACEMENT

#### a. Testing Solenoid Switch Windings

When the cranking motor is removed from engine, the solenoid switch windings may be tested with switch either on or off the cranking motor. Two tests should be made to determine:

- (1) Current draw of both windings in parallel;
- (2) Current draw of hold-in winding alone.

1. Remove the switch-to-motor connector and ground the switch motor terminal to solenoid base with a jumper wire.

2. Connect a 6-volt battery, a variable resistance, and an ammeter of 100 amperes capacity in series with the base of solenoid and the *smallest* of the three terminal studs on switch.

3. Connect a voltmeter between base of solenoid and the *small* terminal stud.

4. Slowly adjust resistance until voltmeter reads 5 volts then note ammeter reading. This shows current draw of both windings in parallel, and should be 85 to 90 amperes at 5 volts, *with solenoid cold (room temperature)*.

5. Remove jumper wire from switch motor terminal and readjust resistance until voltmeter reads 5 volts, then note ammeter reading. This shows current draw of hold-in winding alone, and should be 14 to 16 amperes at 5 volts, *with solenoid cold (room temperature)*.

6. If the solenoid windings do not test within the specifications given, the solenoid switch assembly should be replaced.

#### b. Installing Solenoid Switch and Adjusting Drive Pinion Travel

Whenever the solenoid switch is removed and reinstalled on cranking motor it is necessary to adjust the drive pinion travel so that there will be a clearance of  $\frac{3}{16}'' \pm \frac{1}{32}''$  between the end of pinion and the drive housing when pinion is in cranking position.

1. Install solenoid switch and connect plunger links to shift lever, but *do not* install the switch-to-motor connector.

2. Connect a 6-volt battery to the *small* relay terminal stud on switch and to ground on base of solenoid, then push solenoid plunger into solenoid by hand. Battery current will hold the plunger in the "bottomed" position while the pinion clearance is adjusted.

3. Press finger lightly against outer side of drive assembly shell to take out all lash in shift linkage, but without compressing the clutch spring. Measure clearance between end of pinion and machined surface on drive housing. Clearance should be  $\frac{3}{16}'' \pm \frac{1}{32}''$ . See figure 10-53.

4. If pinion clearance is not correct, loosen switch mounting screws and shift switch on cranking motor to obtain specified clearance. Moving switch toward shift lever increases

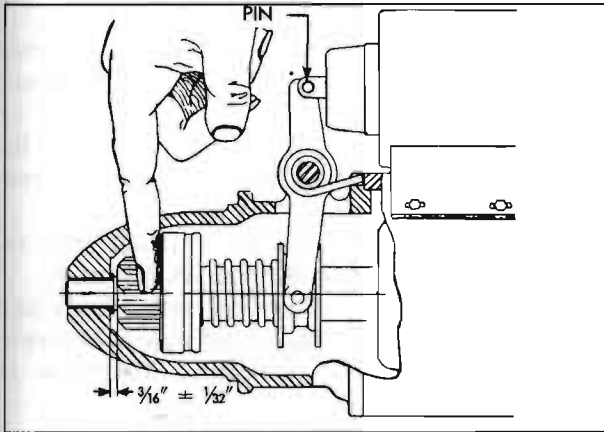

Figure 10-53—Checking Pinion Clearance

pinion clearance and moving switch away from lever decreases clearance.

5. When specified pinion clearance is obtained, tighten switch mounting screws securely and install switch-to-motor connector.

6. Apply several drops of 10-W oil to armature shaft splines and shift lever pivot stud, but do not oil solenoid plunger as this would cause plunger to gum and stick in cold weather.

7. Connect a voltmeter between base of solenoid and the *small* terminal stud on switch.

8. Connect a variable resistance (set for maximum resistance) between the 6-volt battery and base of solenoid, leaving battery connected to the *small* terminal stud on switch.

9. Place a  $\frac{3}{4}$ " block between end of pinion and pinion housing. Adjust the variable resistance until solenoid switch contacts close and immediately note voltage before solenoid heats up. Contacts should close at a maximum of 4.2 volts with solenoid at room temperature.

10. If switch contacts do not close at 4.2 volts maximum, check for binding in solenoid linkage, binding of pinion on armature shaft splines, etc. Correct any binding conditions and recheck switch closing voltage.

## 10-40 BENCH TEST OF CRANKING MOTOR

To obtain full performance data on a cranking motor, or to determine the cause of abnormal operation, the motor should be removed from the engine and be submitted to a no-load and a torque test.

### a. Cranking Motor Tests and Equipment Required

In the no-load test, the cranking motor is connected in series with a 6-volt battery and an

ammeter capable of reading several hundred amperes. A voltmeter is connected between the insulated motor terminal and ground on the frame at a point free of grease and paint. A speed indicator should also be used to measure the armature revolutions per minute.

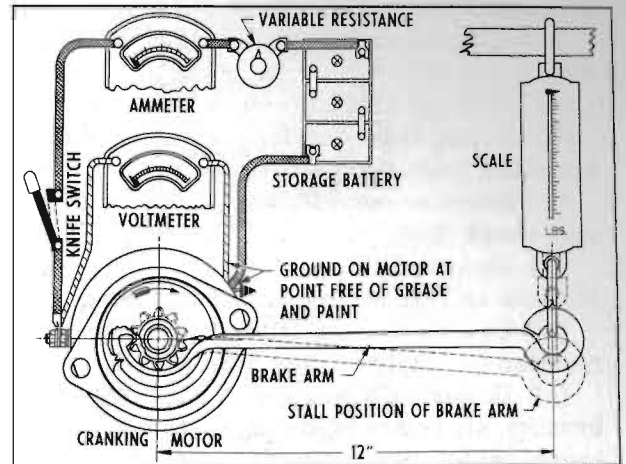

Figure 10-54—Diagrammatic Layout for Cranking Motor Torque Test

The torque test requires equipment such as shown in figure 10-54. The cranking motor is securely mounted and the brake arm hooked to the drive pinion. With a one-foot brake arm as shown, the torque will be indicated directly on the scale in pounds feet when the specified voltage is applied to the motor. Specified voltage is applied through the use of a high-current-carrying variable resistance.

An armature growler and a test lamp with pointed prods on the leads are also required for checking internal condition of armature and the field windings.

### b. Interpreting Results of Tests

Test specifications are given under Electrical Specifications (par. 10-3). The specifications are given at low voltages so that torque and ammeter readings obtained will be within the range of testing equipment available in the field.

1. *Rated torque, current draw and no-load speed* indicates normal condition of cranking motor.

2. *Low free speed and high current draw with low developed torque* may result from:

(a) Tight, dirty, or worn bearings, bent armature shaft or loose field pole screws which would allow the armature to drag.

(b) Shorted armature. Check armature further on growler (par. 10-28, b).

(c) A grounded armature or field. Check by raising the grounded brushes and insulating

them from the commutator with cardboard, and then checking with a test lamp between the insulated terminal and the frame. If lamp lights, raise other brushes from commutator and check fields and commutator separately to determine whether it is the fields or armature that is grounded.

3. *Failure to operate with high current draw may result from:*

- (a) A direct ground in the terminal or fields.
- (b) Frozen shaft bearings which prevent the armature from turning.

4. *Failure to operate with no current draw may result from:*

(a) Open field circuit. Inspect internal connections and trace circuit with test lamp.

(b) Open armature coils. Inspect the commutator for badly burned bars.

(c) Broken or weakened brush springs, worn brushes, high mica on the commutator, or other causes which would prevent good contact between the brushes and commutator. Any of these conditions will cause burned commutator bars.

5. *Low no-load speed with low torque and low current draw indicates:*

(a) An open field winding. Raise and insulate ungrounded brushes from commutator and check field with test lamp.

(b) High internal resistance due to poor connections, defective leads, dirty commutator and causes listed under item 4 (c). Running free speed, an open armature will show excessive arcing at the commutator bar which is open.

6. *High free speed with low developed torque and high current draw indicates shorted fields. There is no easy way to detect shorted fields, since the field resistance is already low. If shorted fields are suspected, replace the fields and check for improvement in performance.*

## 10-41 CRANKING MOTOR REPAIRS— ON BENCH

### a. Disassembly, Cleaning, and Inspection

When it is necessary to disassemble cranking motor for any reason, make a complete clean up and inspection to make sure all parts are in satisfactory condition. See figure 10-56 for identification of parts.

1. Disconnect plunger from shift lever by removing adjusting screw link pin. Remove solenoid switch.

2. Remove commutator cover band and dis-

connect brush leads from the field leads.

3. Unscrew the through bolts and separate the commutator end frame, field frame, and drive housing.

4. On *Series 70* cranking motor, remove the center bearing plate and thrust washer from drive housing.

5. Remove shift lever and spring, then remove drive assembly from drive housing.

6. If field coils are to be removed from field frame, a pole shoe spreader and pole shoe screwdriver should be used to avoid distortion of frame. See figure 10-55.

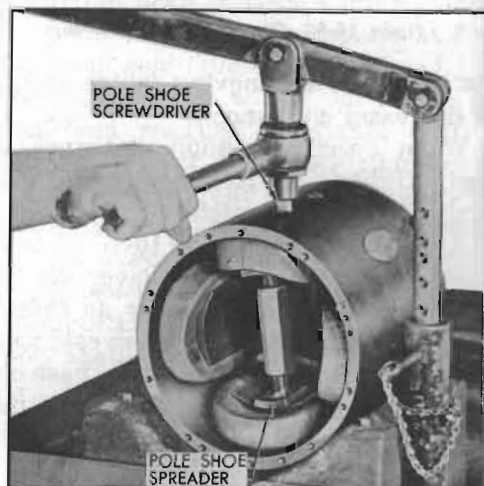

Figure 10-55—Using Pole Shoe Spreader and Screwdriver

7. Clean all parts by wiping with clean cloths. The armature, field coils, and drive assembly must not be cleaned by any degreasing or high temperature method. This might damage insulation so that a short or ground would subsequently develop, and will remove lubricant originally packed in the overrunning clutch so that clutch would soon be ruined.

8. Carefully inspect all parts for wear or damage and make necessary repairs or replace unserviceable parts. If brush springs are distorted or show evidence of overheating, replace them. Any soldering must be done with rosin flux; *never use acid flux on electrical connections.*

9. Test armature and make necessary repairs or turn commutator if required, following the same procedure as specified for generator armature in paragraph. 10-28.

### b. Assembly of Cranking Motor

Assemble cranking motor by reversing disassembly procedure. If field coils were removed, use pole shoe spreader and pole shoe screw-



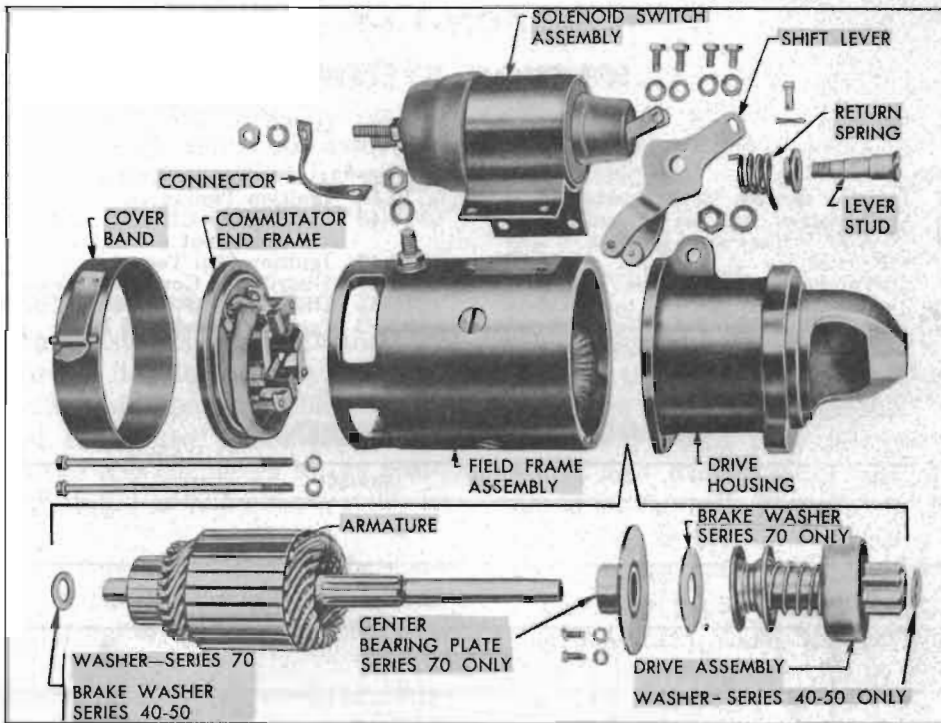

Figure 10-56—Cranking Motor Disassembled

driver to install them, to avoid distorting field frame and to insure proper tightening of pole shoe screws. See figure 10-55.

Before installation of solenoid switch check the shift lever spring for proper tension. A weak spring may cause sluggish disengagement of drive clutch pinion in cold weather, particularly if the shaft is gummed up. With spring scale connected to hole in upper end of shift lever, the pull at start of travel should be 9 to 12 pounds and at end of travel should be 28 to 35 pounds.

When solenoid switch plunger is connected to shift lever, adjust drive pinion travel to provide  $\frac{3}{16}$ " clearance in cranking position as described in paragraph 10-39 (c).

If new brushes were installed, or old brushes were removed from holders, loosen brush attaching screws to allow brushes to seat squarely against commutator, then firmly tighten screws. Attach spring scale at each brush and check the pull required to just lift brush off commutator. Brush spring tension should be 24 to 28 ounces. If spring tension is excessive, pull brush holder out to limit of travel several times to give a slight bend to spring. If spring tension is too light, replace brush spring. Make sure that brush holders do not bind on the support pins.